



website:<http://www.lg.ca>

MICROWAVE OVEN

OWNER'S MANUAL

PLEASE READ THIS OWNER'S MANUAL
THOROUGHLY BEFORE OPERATING.

LMV-2031SB
LMV-2031SS
LMV-2031SW



P/No: 3828W5A3387
Printed in Korea

SAFETY

- **To avoid improperly cooking some foods.**
 - **Do not heat any types of baby bottles or baby food.** Uneven heating may occur and possibly cause personal injury.
 - **Do not heat small-necked containers,** such as syrup bottles.
 - **Do not deep-fat fry in your microwave oven.**
 - **Do not attempt home canning in your microwave oven.**
 - **Do not heat the following items in the microwave oven:** whole eggs in the shell, water with oil or fat, sealed containers, or closed glass jars. These items may explode.
- Do not cover or block any openings in the oven.
- Use your oven only for the operations described in this manual.
- Do not run the oven empty, without food in it.
- Do not let cord hang over edge of table or counter.
- **Preserve the oven floor:**
 - **Do not heat the oven floor excessively.**
 - **Do not** allow the gray film on special microwave-cooking packages to touch the oven floor. Put the package on a microwavable dish.
 - **Do not** cook anything directly on the oven floor or turntable. Use a microwavable dish.
 - Keep a browning dish at least 3/16 inch above floor. Carefully read and follow the instructions for the browning dish. If you use a browning dish incorrectly, you could damage the oven floor.
- Install or locate this appliance only in accordance with the provided installation instructions.
- This appliance should be serviced only by qualified service personnel. Contact the nearest authorized service facility for examination, repair, or adjustment.

SAVE THESE INSTRUCTIONS

PRECAUTIONS TO AVOID POSSIBLE EXPOSURE TO EXCESSIVE MICROWAVE ENERGY...

- (a) Do not attempt to operate this oven with the door open since open-door operation can result in harmful exposure to microwave energy. It is important not to defeat or tamper with the safety interlocks.
- (b) Do not place any object between the oven front face and the door or allow soil or cleaner residue to accumulate on sealing surfaces.
- (c) Do not operate the oven if it is damaged. It is particularly important that the oven door closes properly and that there is no damage to the:
 - (1) Door (bent),
 - (2) Hinges and latches (broken or loosened),
 - (3) Door seals and sealing surfaces.
- (d) The oven should not be adjusted or repaired by anyone except properly qualified service personnel.

TABLE OF CONTENTS

PRECAUTIONS TO AVOID POSSIBLE EXPOSURE TO EXCESSIVE MICROWAVE ENERGY	2	Auto Defrost	19
TABLE OF CONTENTS	3	Weight conversion table	19
SAFETY	4	Operating Tips	19
Important Safety Instructions	4	Auto Defrost Table	20
INFORMATION	5	Defrosting tips	22
Location of Model Number	5	Q Defrost.....	22
Oven Specifications	5	COOKING	23
Electrical Requirements	5	Recipe Guide	23
Grounding Instructions	5	Getting the Best Cooking Results	26
Microwave Oven Features	6	Fish & Shellfish	26
Control panel features	7	Appetizers / Sauces / Soups	27
OPERATION	9	Meat	27
Learn about your Microwave Oven	9	Poultry	29
Clock	9	MAINTENANCE	30
Custom Set	9	Care and Cleaning	30
Child Lock	10	Metal Rack	30
Ez-ON	10	Cleaning the Grease Filters	30
Timer.....	10	Charcoal Filter Replacement.....	30
Light Timer	10	Cooktop/Countertop Light Replacement	31
Hold Warm	11	Oven Light Replacement.....	31
More/Less	11	Questions and Answers	31
Light Hi-Low-Off.....	11	Microwave Utensil Guide	32
Vent 5 Levels	11	TROUBLESHOOTING	33
Auto Touch	12	Before Calling for Service	33
Auto Touch Table	12	WARRANTY	34
Soften	13		
Soften Table	13		
Melt	13		
Melt Table	13		
Cooking at High Cook Power.....	14		
Cooking at Lower Power Levels	14		
Cooking With More Than One Cook Cycle.....	14		
Cooking Guide for Lower Power Levels.....	15		
Sensor Operating Instructions.....	16		
Sensor Cooking Guide	16		
Popcorn.....	16		
Potato.....	16		
Vegetable	17		
Reheat(Sensor).....	17		
Sensor Cooking Table.....	18		
Sensor Reheat Table	18		

SAFETY

IMPORTANT SAFETY INSTRUCTIONS

The safety instructions below will tell you how to use your oven and avoid harm to yourself or damage to your oven.

⚠ WARNING - To reduce the risk of burns, electric shock, fire, injury to persons, or exposure to excessive microwave energy.

- **Read all the instructions before using your oven.**
- **Do not allow children to use this oven without close supervision.**
- Read and follow the specific **PRECAUTIONS TO AVOID POSSIBLE EXPOSURE TO EXCESSIVE MICROWAVE ENERGY** found on page 2.
- **Do not use** corrosive chemicals or vapors, such as sulfide and chloride, in this appliance. This type of oven is specifically designed to heat, cook, or dry food. It is not designed for industrial or laboratory use.
- **Do not use or store** this appliance outdoors. Do not use this product near water - for example, near a kitchen sink, in a wet basement, or near a swimming pool, and the like.
- **Do not use** the cavity for storage purposes. Do not leave paper products, cooking utensils, or food in the cavity when not in use.
- **Clean the ventilating hood frequently.** Do not allow grease to accumulate on the hood or the filters.
- Use care when cleaning the vent hood filters. Corrosive cleaning agents such as lye-based oven cleaners, may damage the filters.
- **Do not tamper with the built-in safety switches on the oven door.** The oven has several built-in safety switches to make sure the power is off when the door is open.
- When food flames under the hood, turn the fan on.
- Suitable for use above both gas and electric cooking equipment 36 inches wide or less.
- **Do not use this oven for commercial purposes.** It is made for household use only.
- **When cleaning the door and the surfaces that touch the door, use only mild, non-abrasive soaps or detergents and a sponge or soft cloth.**
- **If your oven is dropped or damaged,** have it thoroughly checked by a qualified service technician before using it again.
- **To avoid a fire hazard:**
 - **Do not severely overcook food.** Severely overcooked foods can start a fire in the oven. Watch the oven carefully, especially if you have paper, plastic, or other combustibles in the oven.
 - **Do not store combustible items (bread, cookies, etc.) in the oven,** because if lightning strikes the power lines it may cause the oven to turn on.
 - **Do not use wire twist-ties in the oven.** Be sure to inspect purchased items for wire twist-ties and remove them before placing the item in the oven.
- **If a fire should start:**
 - **Keep the oven door closed.**
 - **Turn the oven off.**
 - **Disconnect the power cord or shut off the power at the fuse or circuit breaker panel.**
- **To avoid electric shock:**
 - **This appliance must be grounded.** Connect it only to a properly grounded outlet. See the electrical **GROUNDING INSTRUCTIONS** on page 5.
 - **Do not operate this appliance if it has a damaged cord or plug,** if it is not working properly or if it has been damaged or dropped.
 - **Do not immerse the electrical cord or plug in water.**
 - **Keep the cord away from heated surfaces.**

INFORMATION

Please read this owner's manual. It will tell you how to use all the fine features of this microwave oven.

LOCATION OF MODEL NUMBER

To request service information or replacement parts, the service center will require the complete model number of your microwave oven. The number is on the oven front as shown in the illustration below.

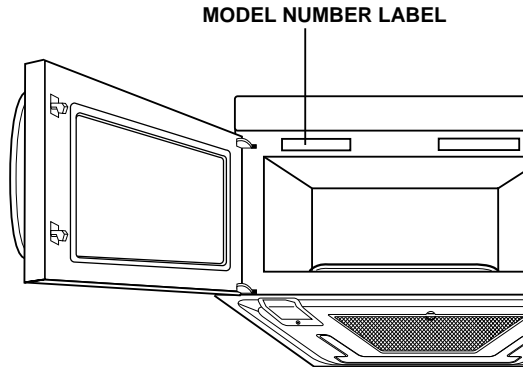

OVEN SPECIFICATIONS

Output Power 1,100W (IEC 60 705)
Outer Dimensions 29-15/16" x 16-7/16" x 15-5/8"
Cavity Volume 2.0 Cu.ft
Net Weight 60 lbs.

ELECTRICAL REQUIREMENTS

The oven is designed to operate on a Standard 120V/60Hz household outlet. Be sure the circuit is at least 15A or 20A and the microwave oven is the **only appliance on the circuit**. It is not designed for 50Hz or any circuit other than a 120V/60Hz circuit.

GROUNDING INSTRUCTIONS

This appliance must be grounded. If an electrical short circuit occurs, grounding reduces the risk of electric shock by providing an escape wire for the electric current. The cord for this appliance has a grounding wire with a grounding plug. Put the plug into an outlet that is properly installed and grounded.

⚠ WARNING - If you use the grounding plug improperly, you risk electric shock.

Ask a qualified electrician if you do not understand the grounding instructions or if you wonder whether the appliance is properly grounded.

Because this appliance fits under the cabinet, it has a short power-supply cord. See the separate Installation Instructions for directions on placing the cord properly. Keep the electrical power cord dry and do not pinch or crush it in any way.

If it is necessary to use an extension cord, use only a 3-wire extension cord that has a 3-blade grounding plug, and a 3-slot receptacle that will accept the plug on the appliance. The marked rating of the extension cord shall be equal to or greater than the electrical rating of the appliance.

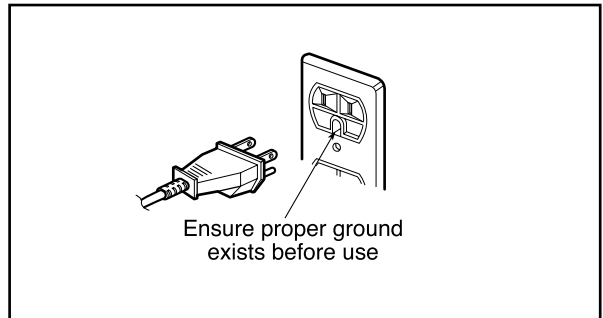

For a permanently connected appliance:
This appliance must be connected to a grounded, metallic, permanent wiring system, or an equipment grounding conductor should be run with the circuit conductors and connected to the equipment grounding terminal or lead on the appliance.

INFORMATION

MICROWAVE OVEN FEATURES

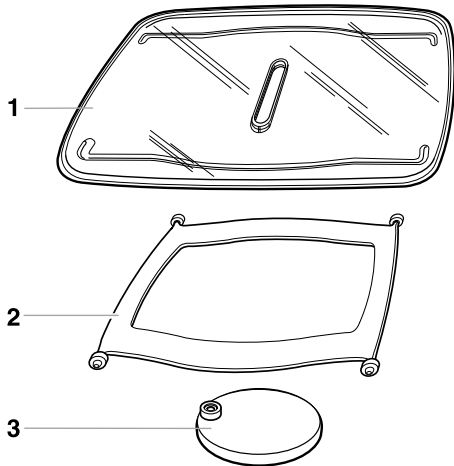
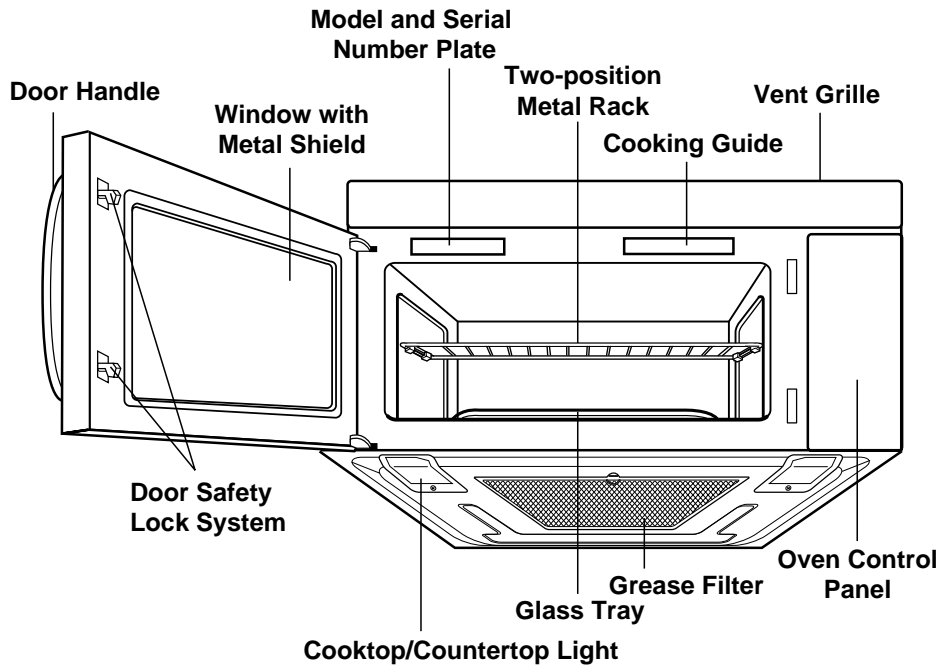

1. Glass tray
2. Support
3. Hub

The glass tray moves in both directions to help cook food more evenly. Do not operate the microwave oven without the glass tray in place.

To Install:

1. Place the support on the oven cavity bottom.
2. Place the glass tray on the support.

Fit the raised, hollowed groove of the glass tray bottom between the rollers of the hub. The rollers on the support should fit inside the glass tray bottom ridge.

INFORMATION

CONTROL PANEL FEATURES

Your microwave oven control panel lets you select the desired cooking function quickly and easily. All you have to do is touch the necessary Command pad. The following is a list of all the Command and Number pads located on the control panel. **For more information on these features, see the “OPERATION” section.**

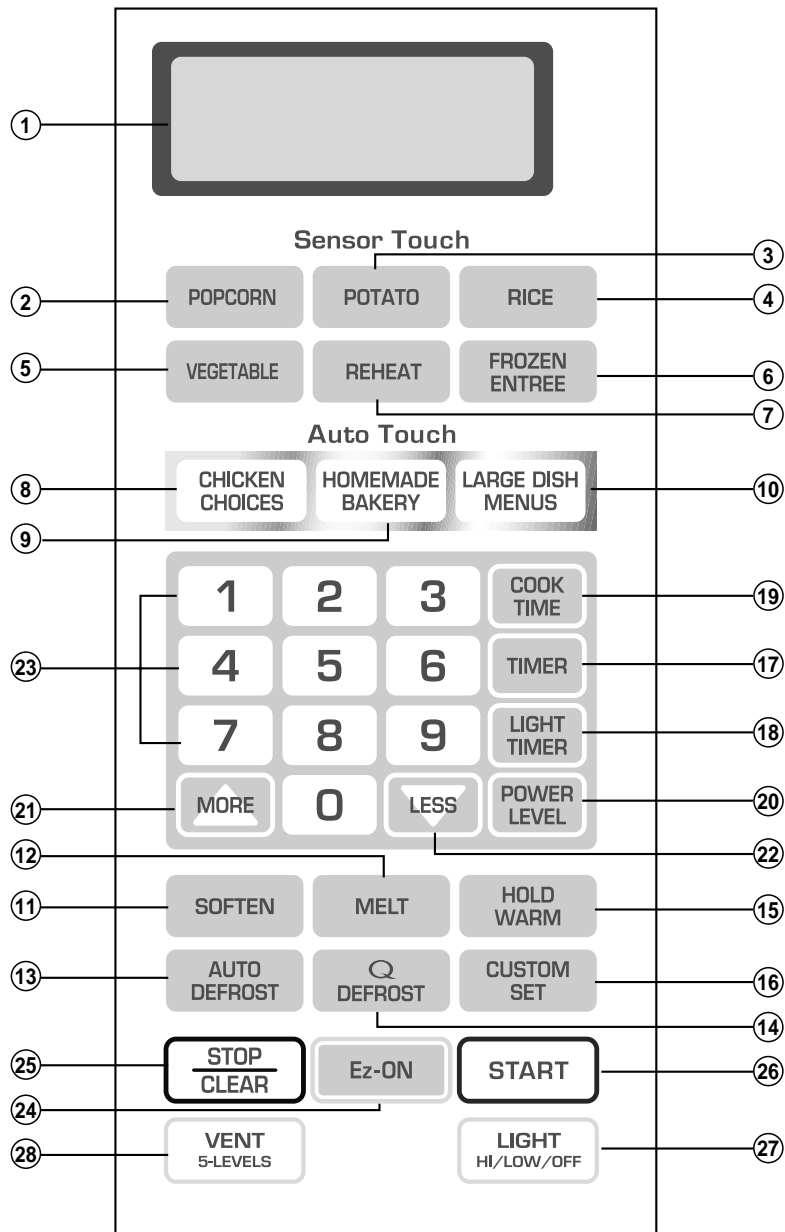

INFORMATION

1. **DISPLAY:** The Display includes a clock and indicators to tell you time of day, cooking time settings and cooking functions selected.
2. **POPCORN:** Touch this pad when popping popcorn in your microwave oven.
3. **POTATO:** Touch this pad to cook potatoes.
4. **RICE:** Touch this pad to cook rice.
5. **VEGETABLE:** Touch this pad to cook vegetables.
6. **FROZEN ENTREE:** Touch this pad to cook frozen entree.
7. **REHEAT:** Touch this pad to reheat casserole, dinner plate soup/sauce and pizza.
8. **CHICKEN CHOICES:** Touch this pad to cook chicken wings, chicken nuggets, spicy chicken and mexican chicken.
9. **HOMEMADE BAKERY:** Touch this pad to cook roll/muffin, pancake, and french toast.
10. **LARGE DISH MENUS:** Touch this pad to cook lasagna, whole chicken, and casserole.
11. **SOFTEN:** Touch this pad to soften ice cream, cream cheese, butter, or frozen juice.
12. **MELT:** Touch this pad to melt chocolate, cheese, butter, or marshmallows.
13. **AUTO DEFROST:** Touch this pad to select food type and defrost food by weight.
14. **Q DEFROST:** This pad provides you with the RAPID defrosting method for 1.0 pound ground beef.
15. **HOLD WARM:** Touch this pad to keep hot, cooked foods warm in your microwave oven for up to 99 minutes 99 seconds.
16. **CUSTOM SET:** Touch this pad to change the oven's default settings for clock set, sound, display speed and defrost weight.
17. **TIMER:** Touch this pad to set the kitchen timer.
18. **LIGHT TIMER:** Touch this pad to set the light timer.
19. **COOK TIME:** Touch this pad followed by Number pads to set a cooking time.
20. **POWER LEVEL:** Touch this pad to select a cooking power level.
21. **MORE:** Touch this pad to add ten seconds of cooking time each time you press it.
22. **LESS:** Touch this pad to subtract ten seconds of cooking time each time you press it.
23. **NUMBER:** Touch number pads to enter cooking time, power level, quantities, or weights.
24. **Ez-ON:** Touch this pad to set and start quickly at 100% power level.
25. **STOP/CLEAR:** Touch this pad to stop the oven or to clear all entries.
26. **START:** Touch this pad to start a function. If you open the door after oven begins to cook, START again.
27. **LIGHT HI-LOW-OFF:** Touch this pad to turn on the cooktop/countertop light.
28. **VENT 5 LEVELS:** Touch this pad to turn the fan on or off.

OPERATION

LEARN ABOUT YOUR MICROWAVE OVEN

This section discusses the concepts behind microwave cooking and introduces you to the basics you need to know to operate your microwave oven. Please read this information before use.

CAUTION

To avoid risk of personal injury or property damage, do not use stoneware, aluminum foil, metal utensils, or metal trimmed utensils in the oven.

CAUTION

To avoid risk of personal injury or property damage, do not run oven empty.

CLOCK

This oven includes a 12-hour clock.

Example: To set 8:00 AM.

CUSTOM SET	1. Touch CUSTOM SET pad.
1	2. Touch 1 pad.
8 0 0	3. Enter the time by using the number key pad.
START	4. Touch START pad.
1	5. Touch 1 pad. (Press 1 for AM, Press 2 for PM)
START	6. Touch START pad.

CUSTOM SET

You can change the default values for clock set, beep sound, display speed and defrost weight. See following chart for more information.

NUMBER	FUNCTION	NUMBER	RESULT
1	Clock set	-	-
2	Beef ON/OFF control	1	Sound ON
		2	Sound OFF
3	Display	1	Slow speed
		2	Normal speed
		3	Fast speed
4	Defrost weight mode select	1	Lbs.
		2	Kg.

Example: To change defrost weight mode.(from Lbs. to Kg.)

CUSTOM SET	1. Touch CUSTOM SET pad.
4	2. Touch number 4 pad.
2	3. Touch number 2 pad.

OPERATION

CHILD LOCK

You may lock the control panel to prevent the microwave from being accidentally started or used by children.

The Child Lock feature is also useful when cleaning the control panel. Child Lock prevents accidental programming when wiping the control panel.

Example: To set the child lock.



1. Touch **STOP/CLEAR** pad.



2. Touch and hold **0** pad more than 4 seconds. **LOCKED** will appear in the display window with two beeps.

Example: To cancel the child lock.



1. Touch and hold **0** pad more than 4 seconds. **LOCKED** will disappear and you hear two beeps. At this time the oven is ready.

Ez-ON

A time-saving pad, this simplified control lets you quickly set and start microwave cooking without the need to touch **START** pad.

Example: To set Ez-On for 2 minutes.



1. Touch **Ez-ON** pad 4 times. The oven begins cooking and display shows time counting down.

NOTE:

If you touch **Ez-ON**, it will add 30 seconds up to 3 minutes; after 3 minutes, every touch will add 1 minute up to 99 min 59 seconds.

TIMER

You can use your microwave oven as a timer. Use the Timer for timing up to 99 minutes, 99 seconds.

Example: To time 3 minutes.



1. Touch **TIMER** pad.

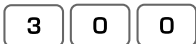

2. Enter the time by using the number key pad.



3. Touch **START** pad. When the time is over, you will hear seven beeps and **END** will display.

LIGHT TIMER

You can set the LIGHT to turn on and off automatically at any time you want. The light comes on at the same time every day until reset.

Example: Turn on 2:00 AM, turn off 7:00 AM.



1. Touch **LIGHT TIMER** pad.



2. Enter the time you want the LIGHT to turn on.



3. Touch **START** pad.



4. Touch **1** pad. (Press 1 for AM., press 2 for PM.)



5. Touch **START** pad.



6. Enter the time you want the LIGHT to turn off.



7. Touch **START** pad.



8. Touch **1** pad. (Press 1 for AM., press 2 for PM.)



9. Touch **START** pad.

NOTE: To reset that time to turn on and off the LIGHT, repeat steps 1 to 9.

Example: To cancel the LIGHT TIMER.



1. Touch **LIGHT TIMER** pad.



2. Touch **STOP/CLEAR** pad.

NOTE: If you want to cancel the LIGHT TIMER in operation, you should touch  key.

OPERATION

HOLD WARM

You can keep cooked food warm in your microwave oven for up to 99 minutes 99 seconds. You can use HOLD WARM by itself or to follow a cooking cycle automatically.

Example: To use the hold warm.

HOLD
WARM

1. Touch **HOLD WARM** pad.

START

2. Touch **START** pad.

NOTES:

- **HOLD WARM** operates for up to 99 minutes 99 seconds.
- **Food cooked covered** should be covered during HOLD WARM.
- **Pastry items** (pies, turnovers, etc.) should be uncovered during HOLD WARM.
- **Complete meals** kept warm on a dinner plate could be covered during HOLD WARM.

To make HOLD WARM automatically follow another cycle:

- While you are programming the cooking instructions, touch HOLD WARM before touching START.
- When the last cooking cycle is over, you will hear two tones and "HOLD WARM" will appear in the oven display.
- You can set HOLD WARM to follow AUTO DEFROST, or multi-cycle cooking.

MORE/LESS

By using the MORE or LESS keys, all of the preprogrammed cook and time cook features can be adjusted to cook food for a longer or shorter time. Pressing MORE will add 10 seconds of cooking time each time you press it. Pressing LESS will subtract 10 seconds of cooking time each time you press it.

LIGHT HI-LOW-OFF

LIGHT
HI/LOW/OFF

Touch **LIGHT** pad once for bright light, twice for night light, or three times to turn the light off.

VENT 5 LEVELS

VENT
5-LEVELS

MODE	Touch pad
HIGH	1 time
MED-HIGH	2 times
MED-LOW	3 times
LOW	4 times
Off	5 times

NOTE: If the temperature from the range or cooktop below the oven gets too hot, the exhaust fan in the vent hood will automatically turn on at the LEVEL 4 setting to protect the oven.

OPERATION

AUTO TOUCH

Auto Touch lets you heat common microwave-prepared foods without selecting cooking times and power levels. Auto Touch has preset cook powers for 3 food functions: Chicken choices, Homemade bakery, Large dish menus.

Example: To cook 6 oz. Chicken wing.

CHICKEN CHOICES

1. Touch **CHICKEN CHOICES** pad.

1

2. Choose food category.

Category	Touch pad number
Chicken wings	1
Chicken nuggets	2
Spicy chicken	3
Mexican chicken	4

1

3. Touch 1 pad.

Amount	Touch pad number
6 oz.	1
12 oz.	2

Example: To cook 2 slices of French toast.

HOMEMADE BAKERY

1. Touch **HOMEMADE BAKERY** pad.

3

2. Choose food category.

Category	Touch pad number
Roll/Muffin	1
Pancake	2
French toast	3

2

3. Touch 2 pad.

Amount	Touch pad number
1 slice	1
2 slices	2
3 slices	3
4 slices	4

AUTO TOUCH TABLE

FUNCTION	CODE	CATEGORY	INSTRUCTIONS	AMOUNT
Chicken choices	1	Chicken wings Frozen, Precooked	Place in a single layer around the edge of a dinner plate or serving platter.	6 or 12 oz.
	2	Chicken nuggets Frozen, Precooked	Place in a single layer around the edge of a dinner plate.	4 or 8 oz.
	3	Spicy chicken	See recipe guide. (page 23)	2 or 4 servings
	4	Mexican chicken	See recipe guide. (page 23)	2 or 4 servings
Homemade bakery	1	Roll / Muffin	Place on oven tray or a plate.	1, 2, 3 or 4 pieces (Fresh)
	2	Pancake	Place in stacks of three pancakes on an appropriate sized plate. Note: Heat toppings for 20~30 seconds before adding to toast.	3 or 6 cakes (Frozen)
	3	French toast	Before serving, add butter, syrup, fruit jam, or whatever suits your taste.	1, 2, 3 or 4 slices
Large dish menus	1	Lasagna	Prepare as directed and cover with plastic wrap. Before serving test noodles in center of dish to determine if cooked properly. Place under broiler for a few minutes if additional browning is desired. See recipe guide. (page 23)	4 ~ 6 servings
	2	Whole chicken	Prepare as directed and always cover with the dish cover or plastic wrap. Check center pieces for internal temperature of 170°F, 76°C. Place under broiler if additional browning or crisping is desired. See recipe guide. (page 24)	3 or 4 lbs.
	3	Casserole	See recipe guide. (page 24)	6 ~ 8 servings

OPERATION

SOFTEN

The oven uses low power to soften foods (butter, ice cream, cream cheese, and frozen juice)
See the following table.

Example for quart of ice cream.	
SOFTEN	1. Touch SOFTEN pad.
2	2. Choose the category. Touch 2 pad for ice cream.
2	3. Touch 2 pad.
When the cook time is over, you will hear four beeps and COOK END will be displayed.	

MELT

The oven uses low power to melt foods (butter or margarine, chocolate, processed cheese food, or marshmallows). See the following table.

Example for 8 oz. Chocolate.	
MELT	1. Touch MELT pad.
2	2. Choose the category. Touch 2 pad for chocolate.
2	3. Touch 2 pad.
When the cook time is over, you will hear four beeps and COOK END will be displayed.	

SOFTEN TABLE

CODE	CATEGORY	DIRECTION	AMOUNT
1	Butter	Unwrap and place in microwavable container. Butter will be at room temperature and ready for use in recipe.	1, 2 or 3 sticks
2	Ice cream	Place container in oven. Ice cream will be soft enough to make scooping easier.	Pint, Quart, Half gallon
3	Cream cheese	Unwrap and place in microwavable Container. Cream cheese will be at room temperature and ready for use in recipe.	3 or 8 oz.
4	Frozen juice	Remove top. Place in oven. Frozen juice will be soft enough to easily mix with water.	6, 12 or 16 oz.

MELT TABLE

CODE	CATEGORY	DIRECTION	AMOUNT
1	Butter or Margarine	Unwrap and place in microwavable container. No need to cover butter. Stir at the end of cooking to complete melting.	1, 2 or 3 sticks
2	Chocolate	Chocolate chips or squares of baking chocolate may be used. Unwrap squares and place in microwavable container. Stir at the end of cycle to complete melting.	4 or 8 oz.
3	Cheese	Use processed cheese food only. Cut into cubes. Place in a single layer in microwavable container. Stir at the end of cooking to complete melting.	8 or 16 oz.
4	Marshmallows	Large or miniature marshmallows may be used. Place in microwavable container. Stir at the end of cycle to complete melting.	5 or 10 oz.

OPERATION

COOKING AT HIGH COOK POWER

Example: To cook food for 8 minutes 30 seconds.

8 **3** **0** 1. Enter the cook time.

START 2. Touch **START** pad.
When the cook time is over, you will hear four beeps and **COOK END** will display.

COOKING AT LOWER POWER LEVELS

HIGH power cooking does not always give you the best results with foods that need slower cooking, such as roasts, baked goods, or custards. Your oven has 10 power settings in addition to HIGH.

Example: To cook food for 7 minutes 30 seconds at 70% power.

7 **3** **0** 1. Enter the cook time.

POWER LEVEL 2. Touch **POWER LEVEL** pad.

7 3. Enter the power level.

START 4. Touch **START** pad.
When the cook time is over, you will hear four beeps and **COOK END** will display.

COOKING WITH MORE THAN ONE COOK CYCLE

For best results, some recipes call for one Power Level for a certain length of time, and another Power Level for another length of time. Your oven can be set to change from one to another automatically, for up to three cycles if the first heating cycle is defrost or the last at 0% power.

Example: To cook food for 3 minutes at 100% power and then 70% power for 7 minutes 30 seconds.

3 **0** **0** 1. Enter the first cook time.

COOK TIME 2. Touch **COOK TIME** pad.

7 **3** **0** 3. Enter the second cook time.

POWER LEVEL 4. Touch **POWER LEVEL** pad.

7 5. Enter the power level.

START 6. Touch **START** pad.
When the cook time is over, you will hear four beeps and **COOK END** will display.

OPERATION

COOKING GUIDE FOR LOWER POWER LEVELS

The nine power levels in addition to HIGH allow you to choose the best power level for the food you are cooking. Below are listed all the power levels,

examples of foods best cooked at each level, and the amount of microwave power you are using.

POWER LEVEL	MICROWAVE OUTPUT	USE
10 HIGH	100%	<ul style="list-style-type: none"> • Boil water. • Cook ground beef. • Make candy. • Cook fresh fruits and vegetables. • Cook fish and poultry. • Preheat browning dish.
9	90%	<ul style="list-style-type: none"> • Reheat meat slices quickly. • Saute onions, celery, and green pepper.
8	80%	<ul style="list-style-type: none"> • All reheating. • Cook scrambled eggs.
7	70%	<ul style="list-style-type: none"> • Cook breads and cereal products. • Cook cheese dishes, veal. • Cook cakes, muffins, brownies, cupcakes.
6	60%	<ul style="list-style-type: none"> • Cook pasta.
5	50%	<ul style="list-style-type: none"> • Cook meats, whole poultry. • Cook custard. • Cook whole chicken, turkey, spare ribs, rib roast, sirloin roast.
4	40%	<ul style="list-style-type: none"> • Cook less tender cuts of meat. • Reheat frozen convenience foods.
3	30%	<ul style="list-style-type: none"> • Thawing meat, poultry, and seafood. • Cooking small quantities of food. • Finish cooking casserole, stew, and some sauces.
2	20%	<ul style="list-style-type: none"> • Soften butter and cream cheese. • Heating small amounts of food.
1	10%	<ul style="list-style-type: none"> • Soften ice cream. • Raise yeast dough.
0		<ul style="list-style-type: none"> • Standing time.

OPERATION

SENSOR OPERATING INSTRUCTIONS

Sensor Cook allows you to cook most of your favorite foods without selecting cooking times and power levels. The oven automatically determines required cooking time for each food item. When the internal sensor detects a certain amount of humidity coming from the food, it will tell the oven how much longer to heat. The display will show the remaining heating time. For best results for cooking by Sensor, following these recommendations.

1. Food cooked with the sensor system should be at normal storage temperature.
2. Glass Tray and outside of container should be dry to assure best cooking results.
3. Foods should always be covered loosely with microwavable plastic wrap, waxed paper, or a lid.
4. Do not open the door or touch the **STOP/CLEAR** key during the sensing time. When sensing time is over, the oven beeps and the remaining cooking time will appear in the display window. At this time you can open the door to stir, turn, or rearrange the food.

SENSOR COOKING GUIDE

Appropriate containers and coverings help assure good Sensor cooking results.

1. Always use microwavable containers and cover them with lids or vented plastic wrap.
2. Never use tight-sealing plastic covers. They can prevent steam from escaping and cause food to overcook.
3. Match the amount of the size of the container. Fill containers at least half full for best results.
4. Be sure the outside of the cooking container and the inside of the microwave oven are dry before placing food in the oven. Beads of moisture turning into steam can mislead the sensor.

POPCORN

POPCORN lets you pop commercially packaged microwave popcorn. Pop only one package at a time. For best results, use fresh bags of popcorn.

Example: To pop popcorn.

POPCORN

1. Touch **POPCORN** pad. When the cook time is over, you will hear four beeps and **COOK END** will display.

CAUTION

Do not leave microwave oven unattended while popping. When popping commercially packaged popcorn, **Remove the rack from the oven**; Do not place the bag of microwave popcorn on the rack or under the rack.

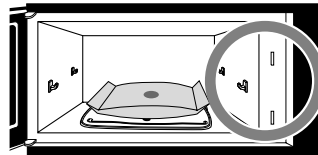
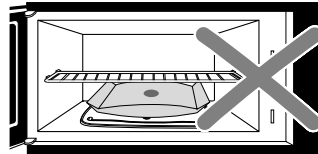
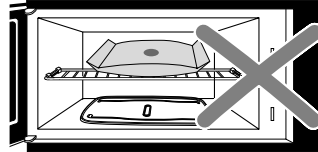

POTATO

The POTATO pad lets you bake one or several potatoes without selecting cooking times and power levels.

NOTE:

- **Before baking**, pierce potato with fork several times.
- **After baking**, let stand for 5 minutes.

Example: To cook 2 potatoes.

POTATO

1. Touch **POTATO** pad. When the cook time is over, you will hear four beeps and **COOK END** will display.

OPERATION

VEGETABLE

VEGETABLE has preset cook powers for 3 food categories: **Fresh, Frozen, and Canned.**

Example: To reheat Frozen Vegetable.

VEGETABLE

1. Touch **VEGETABLE** pad.

2

2. Choose food category.

Category	Touch pad number
Fresh	1
Frozen	2
Canned	3

When the cook time is over, you will hear four beeps and **COOK END** will display.

NOTE: Place the Canned Vegetable in a microwaveable bowl or casserole. Cover with plastic wrap and vent. Let stand 5 minutes.

REHEAT(Sensor)

REHEAT lets you heat foods without needing to program times and Cook Powers.

REHEAT has preset Cook Powers for 4 categories: **Dinner Plate, Soup/Sauce, Casserole, and Pizza.**

Example: To reheat Casserole.

REHEAT

1. Touch **REHEAT** pad.

3

2. Choose food category.

Category	Touch pad number
Dinner Plate	1
Soup/Sauce	2
Casserole	3
Pizza	4

When the cook time is over, you will hear four beeps and **COOK END** will display.

OPERATION

SENSOR COOKING TABLE

CATEGORY		DIRECTION	AMOUNT
Popcorn		Popcorn lets you pop commercially packaged microwave popcorn. Pop only one package at a time. For best results, use fresh bag of popcorn. Place bag of prepackaged microwave popcorn on the center of glass tray.	3.0~3.5 oz. package
Potato		Pierce each potato with a fork and place the oven tray around the edge, at least one inch apart. After cooking, allow to stand for 5 minutes.	1~4 medium (approx. 8 to 10 oz. each)
Rice		Add twice the amount of water to the rice. Use a microwave container large enough to prevent water from boiling over dish. Cover with plastic wrap or lid.	½~2 cups
Vegetable	Fresh Vegetable	Prepare as desired, wash and leave residual water on the vegetables. Place in an appropriately sized microwave container. Add amount of water according to the quantity. (1~2 cups : 2 tablespoons, 3~4 cups : 4 tablespoons). Cover with plastic wrap and vent. After cooking, stir and allow to stand for 3 minutes.	1~4 cups
	Frozen Vegetable	Remove from package, rinse off frost under running water. Place in an appropriately sized microwave container. Add amount of water according to the quantity. (1~2 cups : 2 tablespoons, 3~4 cups : 4 tablespoons). Cover with plastic wrap and vent. After cooking, stir and allow to stand for 3 minutes.	1~4 cups
	Canned Vegetable	Remove from the outer display can. Place in an appropriately sized microwave container, cover with plastic wrap and vent. After cooking, stir and allow to stand for 3 minutes.	1~4 cups
Frozen Entree		Remove from outer display package. Slit cover. If not in microwave-safe container, place on a plate. Cover with plastic wrap and vent the plastic film by piercing with a fork (3 times). After cooking, allow to stand for 3 minutes.	10 to 21 oz.

SENSOR REHEAT TABLE

CATEGORY	TOUCH NUMBER PAD	DIRECTION	AMOUNT
Dinner Plate (Sensor)	1	Place on a low plate. Cover with vented plastic wrap. Let stand 3 minutes.	1~2 servings
Soup/Sauce (Sensor)	2	Place in shallow microwavable casserole. Cover with vented plastic wrap. After cooking, stir and let stand 3 minutes.	1~4 cups
Casserole (Sensor)	3	Cover dish containing the casserole with plastic wrap and vent. After cooking, stir and allow to stand for 3 minutes.	1~4 cups
Pizza	4	This is reheat function for a leftover pizza. Place on paper towel on a microwave safe plate.	1~3 slices (5 oz. each)

OPERATION

AUTO DEFROST

Four defrost sequences are preset in the oven. The auto defrost feature provides you with the best defrosting method for frozen foods. The cooking guide will show you which defrost sequence is recommended for the food you are defrosting. For added convenience, the Auto Defrost includes a built-in beep mechanism that reminds you to check, turn over, separate, or rearrange to get best defrost results.

Example: To defrost 1.2 lbs. of meat.

AUTO DEFROST

1. Touch **AUTO DEFROST** pad.

1

2. Choose food category.

Category	Touch pad number
Meat	1
Poultry	2
Fish	3
Bread	4

1

2

3. Enter the weight.

START

4. Touch **START** pad.

NOTE: When you touch the **START** pad. The display changes to defrost time count down. The oven will beep during the DEFROST cycle. At this time, open the door and turn food over, separate or rearrange the food. Remove any portions that have thawed. The oven will not STOP during the beep unless the door is opened.

START

5. Close the door and restart.

When the defrost time is over, you will hear four beeps and **COOK END** will display.

NOTE: If you do not open the door, the display will resume the countdown.

This table shows you food type selections and the weights you can set for each type. For best results, loosen or remove covering on food.

FOOD	TOUCH Auto Defrost	WEIGHTS YOU CAN SET (tenths of a pound)
Meat	1	.1 to 6.0 (45g to 2722g)
Poultry	2	.1 to 6.0 (45g to 2722g)
Fish	3	.1 to 6.0 (45g to 2722g)
Bread	4	.1 to 1.0 (45g to 450g)

WEIGHT CONVERSION TABLE

You are probably used to food weights as being in pounds and ounces that are fractions of a pound (for example, 4 ounces equals 1/4 pound). However, in order to enter food weight in Auto Defrost, you must specify pounds and tenths of a pound.

If the weight on the food package is in fractions of a pound, you can use the following table to convert the weight to decimals.

EQUIVALENT WEIGHT

OUNCES	DECIMAL WEIGHT	
1.6	.10	
3.2	.20	
4.0	.25	One-Quarter Pound
4.8	.30	
6.4	.40	
8.0	.50	One-Half Pound
9.6	.60	
11.2	.70	
12.0	.75	Three-Quarters Pound
12.8	.80	
14.4	.90	
16.0	1.00	One Pound

OPERATING TIPS

- For best results, remove fish, shellfish, meat, and poultry from its original closed paper or plastic package (wrapper). Otherwise, the wrap will hold steam and juice close to the foods, which can cause the outer surface of the foods to cook.
- For best results, shape your ground meat into the form of a doughnut before freezing. When defrosting, scrape off thawed meat when the beep sounds and continue defrosting.
- Place foods in a shallow container or on a microwave roasting rack to catch drippings.

OPERATION

AUTO DEFROST TABLE

Meat setting

FOOD	SETTING	AT BEEP	SPECIAL INSTRUCTIONS
BEEF			Meat of irregular shape and large, fatty cuts of meat should have the narrow or fatty areas shielded with foil at the beginning of a defrost sequence.
Ground Beef, Bulk	MEAT	Remove thawed portions with fork. Turn over. Return remainder to oven.	Do not defrost less than 1/4 lb. Freeze in doughnut shape.
Ground Beef, Patties	MEAT	Separate and rearrange.	Do not defrost less than 2 oz. patties. Depress center when freezing.
Round Steak	MEAT	Turn over. Cover warm areas with aluminum foil.	Place on a microwavable roasting rack.
Tenderloin Steak	MEAT	Turn over. Cover warm areas with aluminum foil.	Place on a microwavable roasting rack.
Stew Beef	MEAT	Remove thawed portions with fork. Separate remainder. Return remainder to oven.	Place in a microwavable baking dish.
Pot Roast, Chuck Roast	MEAT	Turn over. Cover warm areas with aluminum foil.	Place on a microwavable roasting rack.
Rib Roast	MEAT	Turn over. Cover warm areas with aluminum foil.	Place on a microwavable roasting rack.
Rolled Rump Roast	MEAT	Turn over. Cover warm areas with aluminum foil.	Place on a microwavable roasting rack.
LAMB			
Cubes for Stew	MEAT	Remove thawed portions with fork. Return remainder to oven.	Place in a microwavable baking dish.
Chops (1 inch thick)	MEAT	Separate and rearrange.	Place on a microwavable roasting rack.
PORK			
Chops (1/2 inch thick)	MEAT	Separate and rearrange.	Place on a microwavable roasting rack.
Hot Dogs	MEAT	Separate and rearrange.	Place on a microwavable roasting rack.
Spareribs Country-style Ribs	MEAT	Turn over. Cover warm areas with aluminum foil.	Place on a microwavable roasting rack.
Sausage, Links	MEAT	Separate and rearrange.	Place on a microwavable roasting rack.
Sausage, Bulk	MEAT	Remove thawed portions with fork. Turn over. Return remainder to oven.	Place in a microwavable baking dish.
Loin Roast, Boneless	MEAT	Turn over. Cover warm areas with aluminum foil.	Place on a microwavable roasting rack.

OPERATION

AUTO DEFROST TABLE (CONT.)

Poultry setting

FOOD	SETTING	AT BEEP	SPECIAL INSTRUCTIONS
CHICKEN Whole (up to 6 lbs)	POULTRY	Turn over (finish defrosting breast-side down). Cover warm areas with aluminum foil.	Place chicken breast-side up on a microwavable roasting rack. Finish defrosting by immersing in cold water. Remove giblets when chicken is partially defrosted.
Cut-up		Separate pieces and rearrange. Turn over. Cover warm areas with aluminum foil.	Place on a microwavable roasting rack. Finish defrosting by immersing in cold water.
CORNISH HENS Whole	POULTRY	Turn over. Cover warm areas with aluminum foil.	Place on a microwavable roasting rack. Finish defrosting by immersing in cold water.
TURKEY Breast (up to 6 lbs)	POULTRY	Turn over. Cover warm areas with aluminum foil.	Place on a microwavable roasting rack. Finish defrosting by immersing in cold water.

Fish setting

FOOD	SETTING	AT BEEP	SPECIAL INSTRUCTIONS
FISH Fillets	FISH	Turn over. Separate fillets when partially thawed if possible.	Place in a microwavable baking dish. Carefully separate fillets under cold water.
Steaks	FISH	Separate and rearrange.	Place in a microwavable baking dish. Run cold water over to finish defrosting.
Whole	FISH	Turn over.	Place in a microwavable baking dish. Cover head and tail with foil; do not let foil touch sides of microwave. Finish defrosting by immersing in cold water.
SHELLFISH Crabmeat	FISH	Break apart. Turn over.	Place in a microwavable baking dish.
Lobster tails	FISH	Turn over and rearrange.	Place in a microwavable baking dish.
Shrimp	FISH	Separate and rearrange.	Place in a microwavable baking dish.
Scallops	FISH	Separate and rearrange.	Place in a microwavable baking dish.

OPERATION

AUTO DEFROST TABLE (CONT.)

Bread setting

FOOD	SETTING	AT BEEP	SPECIAL INSTRUCTIONS
Bagel Dinner Roll Muffin Hamburger Hot Dog Bun Slices of Bread Loaf of Bread	BREAD	Turn over and rearrange.	Place on 3 sheets of paper towel.

DEFROSTING TIPS

- **When using** Auto Defrost, the weight to be entered is the net weight in pounds and tenths of pounds (the weight of the food minus the container).
- **Before starting**, make sure you have removed any of the metal twist-ties which often come with frozen food bags, and replace them with strings or elastic bands.
- **Open containers** such as cartons before they are placed in the oven.
- **Always slit** or pierce plastic pouches or packaging.
- **If food is foil wrapped**, remove foil and place it in a suitable container.
- **Slit** the skins, if any, of frozen food such as sausage.
- **Bend** plastic pouches of food to ensure even defrosting.
- **Always underestimate** defrosting time. If defrosted food is still icy in the center, return it to the microwave oven for more defrosting.
- **The length** of defrosting time varies according to how solidly the food is frozen.
- **The shape of the package** affects how quickly food will defrost. Shallow packages will defrost more quickly than a deep block.
- **As food begins to defrost**, separate the pieces. Separated pieces defrost more easily.
- **Use small pieces of aluminum foil** to shield parts of food such as chicken wings, leg tips, fish tails, or areas that start to get warm. Make sure the foil does not touch the sides, top, or bottom of the oven. The foil can damage the oven lining.
- **For better results**, let food stand after defrosting. (For more information on standing time, see the "Microwave Cooking Tips" section.)
- **Turn over** food during defrosting or standing time. Break apart and remove food as required.

Q DEFROST

The Q DEFROST feature provides you with the rapid defrosting method for 1.0 pound ground beef. The oven automatically sets the defrosting time for ground beef.

Example: To defrost ground beef.

<div style="border: 1px solid gray; border-radius: 10px; padding: 5px; background-color: #d0d0d0; display: inline-block;"> Q DEFROST </div>	1. Touch Q DEFROST pad.
<div style="border: 1px solid black; border-radius: 10px; padding: 5px; display: inline-block;">START</div>	2. Touch START pad.

COOKING

RECIPE GUIDE

SPICY CHICKEN - 2 servings (double the ingredients for 4 servings)

- 1 ½ pounds skinless, chicken pieces
- ½ teaspoon cayenne pepper
- 1 tablespoon paprika
- ½ teaspoon pepper
- ¼ cup hot sauce or 1 tablespoon Tabasco sauce
- ½ cup barbecue sauce of choice

Mix everything in an 8 X 8-glass dish or similar dish and cover with plastic wrap.

Cook on 'Spicy Chicken'. Stir and serve as is or place under a broiler for a few minutes for additional browning.

MEXICAN CHICKEN - 2 servings (double the ingredients for 4 servings)

- ½ medium onion, chopped
- ½ green bell pepper, diced
- ½ cup frozen peas
- ½ cup long grain rice
- 1 cup water
- ½ cup salsa
- 1 ½ pounds skinless, chicken pieces, legs, thighs, breasts, wings, or combination of all
- 1 teaspoon cumin
- Salt and pepper to taste
- ½ cup green olives w/pimentos

Place onions and peppers in an 8 X 8-inch glass dish or similar container and microwave for 3-minutes.

Add peas, rice, water, salsa, chicken, and cumin.

Season with salt and pepper.

Cover with plastic wrap and cook on 'Mexican Chicken'. Stir in the olives and serve as is or place under a broiler for a few minutes to add additional browning.

LASAGNA

- 1 pound lean ground beef
- 4 cups prepared spaghetti sauce
- 2 cups ricotta or cottage cheese
- 1 large egg, beaten
- 1 tablespoon dried Italian style herbs
- 1 box oven ready lasagna noodles (12 noodles)
- 1 pound Monterey Jack or mozzarella cheese, shredded
- 1 cup grated Parmesan cheese

Place beef in a 6 cup microwave dish and microwave on high for 5 minutes or until no longer pink. Break apart into crumbled beef. Stir in the sauce, egg, and herbs. Mix the cheese. Spread ¼th of the sauce on the bottom of a 13 X 9 inch oblong dish and lay on 3 noodles. Spread ⅓rd of the cheese mixture over the noodles and another ¼th of the sauce over the cheese. Add another layer of noodles and continue layering the ingredients with a layer of noodles on the top covered with sauce and cheese. Cover with plastic wrap. Cook on 'Lasagna'. Let stand 5 minutes before serving. Serve with sour cream.

COOKING

WHOLE CHICKEN

- 4 frozen Cornish hens, about 1 pound each, without giblets
- Salt and pepper to taste
- Poultry seasoning

Place the birds in a 13 X 9 inch oblong dish, breast side down and cover with plastic wrap.

Cook on 'Whole Chicken'.

After 15 minutes, turn birds over, season, inside and out, and brush with Kitchen Bouquet browning sauce. Recover and cook for remaining time.

Place in the hot oven for 10 minutes for additional browning.

WHOLE CHICKEN

- 3-4 pounds frying chicken
- 2 tablespoons dried or fresh rosemary, chopped
- Salt and pepper to taste

Season the chicken, inside and out, and place, breast side down in an 13 X 9 inch oblong dish.

Cover with plastic wrap and cook on 'Whole Chicken'.

Pour off the juices and turn the chicken, breast side up and place in the hot oven for 10 minutes or until the skin is brown and crisp.

CASSEROLE (Pork chop)

- 1 ½ pounds small red potatoes, quartered
- 1 medium onion, chopped
- 1 large apple, cored and diced
- 1 pound sauerkraut
- 1 can, 10 ounces, cream of mushroom soup
- 1 cup sour cream
- 2 pounds pork chops, ½ inch thick
- salt and pepper to taste

Place the potatoes and onions in a 13 X 9-inch oblong dish or similar 3-quart microwave dish.

Cover with plastic wrap and microwave on high for 3 minutes.

Meanwhile, mix the apple, kraut, soup, and sour cream.

Pour this mixture over the potatoes and onions and lay the chops over the top.

Season and cover with plastic wrap.

Cook on 'Casserole'. Stir at beep.

Serve as is or place under a broiler for a few minutes until browned

COOKING

CASSEROLE (Ham and Sausage Jambalaya)

- 3 cups smoked sausage pieces
- 2 cups cooked ham
- 1 medium onion, chopped
- 1 small green bell pepper, cored and chopped
- 3 cloves garlic, minced
- ½ cup chopped parsley
- 4 tablespoons tomato paste
- 1 can tomatoes with chilies
- 1 cup long grain rice
- 2 cups water
- salt and pepper to taste

Place the first 5 ingredients in a 13 X 9 inch oblong dish and microwave for 5 minutes. Add the other ingredients and stir to blend. Cover with plastic wrap and cook on 'Casserole'. Stir at beep.

CASSEROLE (Beef-noodle bake)

- 2 pounds lean ground beef
- 1 medium onion, chopped
- 1 large green bell pepper, cored and chopped
- 4 cloves garlic, minced
- 2 cans, 14oz., stewed tomatoes
- 4 tablespoons beef granules
- 8 ounces dried egg noodles
- salt and pepper to taste

Crumble the beef in a 13 X 9 inch oblong dish with the onion, pepper, and garlic. Microwave on high power for 4 minutes, stir and microwave another 4 minutes. Meanwhile, dissolve the beef granules in the stewed tomatoes. Stir the noodles and stewed tomatoes into the ground beef mixture and cover with plastic wrap. Cook on 'Casserole'. Stir at beep.

COOKING

GETTING THE BEST COOKING RESULTS

To get the best results from your microwave oven, read and follow the guidelines below.

- **Storage Temperature:** Foods taken from the freezer or refrigerator take longer to cook than the same foods at room temperature. The time for recipes in this book is based on the normal storage temperature of the food.
- **Size:** Small pieces of food cook faster than large ones, pieces similar in size and shape cook more evenly. For even cooking, reduce the power when cooking large pieces of food.
- **Natural Moisture:** Very moist foods cook more evenly because microwave energy is attracted to water molecules.
- **Stir** foods such as casseroles and vegetables from the outside to the center to distribute the heat evenly and speed cooking. Constant stirring is not necessary.
- **Turn over** foods like pork chops, baking potatoes, roasts, or whole cauliflower halfway through the cooking time to expose all sides equally to microwave energy.
- **Place** delicate areas of foods, such as asparagus tips, toward the center of the dish.
- **Arrange** unevenly shaped foods, such as chicken pieces or salmon steaks, with the thicker, meatier parts toward the outside of the dish.
- **Shield**, with **Small** pieces of aluminum foil, parts of food that may cook quickly, such as wing tips and leg ends of poultry.
- **Let It Stand:** After you remove the food from the microwave, cover food with foil or casserole lid and let it stand to finish cooking in the center and avoid overcooking the outer edges. The length of standing time depends on the density and surface area of the food.
- **Wrapping in waxed paper or paper towel:** Sandwiches and many other foods containing prebaked bread should be wrapped prior to microwaving to prevent drying out.

Fish & Shellfish

Cooking Fish and Shellfish: General Directions

- Prepare the fish for cooking.
 - Completely defrost the fish or shellfish.
 - Arrange unevenly shaped pieces with thicker parts toward the outside of the dish. Arrange shellfish in a single layer for even cooking.
 - The type of cover you use depends on how you cook. Poached fish needs a microwavable lid or **vented** plastic wrap.
 - Baked fish, coated fish, or fish in sauce needs to be covered lightly with waxed paper to keep the coating crisp and sauce from getting watery.
- Always set the shortest cooking time. Fish is done when it turns opaque and the thickest part begins to flake. Shellfish is done when the shell turns from pink to red and the flesh is opaque and firm.
- The Fish and Shellfish Cooking Table below provides specific directions with Power Level and Cooking Time settings for most types of fish and shellfish.

Fish And Shellfish Cooking Table

FISH	POWER LEVEL	COOKING TIME	DIRECTIONS
Fish fillets	HI	3 1/2-4 1/2 minutes	Arrange fish in a single layer with thickest portion toward outside edge of 1 1/2 quart microwavable baking dish. Brush with melted butter and season, if desired. Cook covered with vented plastic wrap. Let stand covered 2 minutes. If you are cooking more than 1 lb. of fish, turn the fish halfway through cooking.
Fish steaks	HI	4 1/2-5 1/2 minutes	
Whole fish	7	4 1/2-6 minutes	
Scallops	HI	3 1/2-5 minutes	Arrange in a single layer. Prepare as directed above, except stir instead of turning the shellfish.
Shrimp, shelled	HI	3 1/2-5 minutes	

COOKING

Appetizers / Sauces / Soups

Cooking Appetizers: Tips and Techniques

Recommended

- Crisp crackers, such as melba toast, shredded wheat, and crisp rye crackers are best for microwave use. Wait until party time to add the spreads. Place a paper towel under the crackers while they cook in the microwave oven to absorb extra moisture.
- Arrange individual appetizers in a circle for even cooking.
- Stir dips to distribute heat and shorten cooking time.

Cooking Sauces: Tips and Techniques

- Use a microwavable casserole or glass measuring cup that is at least 2 or 3 times the volume of the sauce.
- Sauces made with cornstarch thicken more rapidly than those made with flour.

Cooking Soups: Tips and Techniques

- Cook soups in a microwavable dish which holds double the volume of the recipe ingredients to prevent boil-over, especially if you use cream or milk in the soup.
- Generally, cover microwaved soups with VENTED plastic wrap or a microwavable lid.
- Cover foods to retain moisture. Uncover foods to retain crispness.
- Avoid overcooking by using the minimum suggested time. Add more time, if necessary, only after checking the food.

Not Recommended

- Appetizers with a crisp coating or puff pastry are best done in a conventional oven with dry heat.
- Breaded products can be warmed in the microwave oven but will not come out crisp.
- Cook sauces made with cornstarch or flour uncovered so you may stir them 2 or 3 times during cooking for a smooth consistency.
- To adapt a conventional sauce or gravy recipe, reduce the amount of liquid slightly.
- Stirring occasionally will help blend flavors, distribute heat evenly, and may even shorten the cooking time.
- When converting a conventional soup recipe to cook in the microwave, reduce the liquid, salt, and strong seasonings.

Meat

Cooking Meat: General Directions

- Prepare the meat for cooking.
 - Defrost completely.
 - Trim off excess fat to avoid splattering.
 - Place the meat, fat side down, on a microwavable rack in a microwavable dish.
 - Use oven cooking bag for less tender cuts of meat.
 - Arrange the meat so that thicker portions are toward the outside of the dish.
 - Cover the meat with waxed paper to prevent splattering.
- Tend the meat as it cooks.
 - Drain juices as they accumulate to reduce splattering and keep from overcooking the bottom of the meat.
 - Shield thin or bony portions with strips of foil to prevent overcooking.

NOTE: Keep the foil **at least 1 inch** from the oven walls, and do not cover more than one-third of the meat with foil at any one time.

- Let the meat stand covered with foil 10-15 minutes after you remove it from the oven. The internal temperature of the meat may rise from 5-10°F during standing time.

The Meat Cooking Table on the next page provides detailed directions, Power Level, and Cooking Time settings for most cuts of meat.

COOKING

Meat Cooking Table

MEAT	POWER LEVEL	COOKING TIME	DIRECTIONS
Beef Hamburgers, Fresh or defrosted (4 oz. each) 1 patty 2 patties 4 patties	HI	1-1½ minutes 1½-2 minutes 2½-3½ minutes	Form patties with depression in center of each. Place on microwavable roast rack. Brush with browning agent, if desired. Cover with waxed paper. Turn over halfway through cooking. Let stand covered 1 minute.
Sirloin tip roast (3-4 lbs.)	5	8-10 minutes per pound RARE(135°F) 11-13 minutes per pound MEDIUM(155°F)	Place roast fat side down on microwavable roast rack. Add desired seasonings and cover with waxed paper. Turn meat over halfway through cooking and shield if necessary. Remove roast from microwave oven when desired temperature is reached. Let stand covered with foil 15 minutes.(Temperature may rise about 10°F).
Lamb Lamb roast, rolled boneless (3-4 lbs.)	5	11-12 minutes per pound RARE(135°F) 12-13 minutes per pound MEDIUM(145°F) 13-14 minutes per pound WELL(155°F)	Place roast fat side down on microwavable roast rack. Brush lamb with marinade or desired seasonings such as rosemary, thyme or marjoram. Cover with waxed paper. Turn roast over after 15 minutes, and again after 30 minutes. Shield if necessary. Remove roast from microwave when desired temperature is reached. Let stand covered with foil 15 minutes (Temperature may rise about 10°F).
Pork Bacon slices 2 slices 4 slices 6 slices	HI	1½-2 minutes 2½ -3 minutes 3½-4½ minutes	Place bacon slices on microwavable roast rack. Cover with paper towels. After cooking, let stand 1 minute.
Chops (5-7 oz. each) 2 chops 4 chops	3	18-20 minutes per pound 15-17 minutes per pound	Place chops in microwavable baking dish. Add desired seasonings and cover with vented plastic wrap. Cook until no longer pink or until internal temperature reaches 170°F. Turn chops over halfway through cooking. Let stand covered 5 minutes. (Temperature may rise about 10°F).
Loin Roast, rolled, boneless (3 ½- 4 ½ lbs.)	3	25-27 minutes per pound (165°F)	Place roast in cooking bag in microwavable dish. Add seasonings and browning agent if desired. Close bag loosely with microwavable closure or string. After cooking, let stand in bag 15 minutes. (Temperature may rise about 10°F.) Internal temperature of pork should reach 170°F before serving.
Sausage links, Fresh or Frozen, defrosted (1-2 oz. each) 2 links 4 links 6 links 10 links (8 oz. pkg.)	HI	45-60 seconds 1-1½ minutes 1½-2 minutes 1¾-2 minutes	Pierce links and place on microwavable roast rack. Cover with waxed paper or paper towel. Turn over halfway through cooking. After cooking, let stand covered 1 minute.

COOKING

Poultry

Cooking Poultry: General Directions

- Prepare the poultry for cooking.
 - Defrost completely.
 - Arrange poultry pieces with thicker pieces at the outside edge of the baking dish. When cooking legs, arrange them like the spokes of a wheel.
 - Cover the baking dish with waxed paper to reduce splattering.
 - Use a browning agent or cook with a sauce to give a browned appearance.
- Tend the poultry as it cooks.
 - Drain and discard juices as they accumulate.
 - Shield thin or bony pieces with small strips of aluminum foil to prevent overcooking. Keep foil **at least 1 inch** from the oven walls and other pieces of foil.
- The poultry is done when it is no longer pink and the juices run clear. When done, the temperature in the thigh meat should be 180-185°F.
- Let the poultry stand after cooking covered with foil for 10 minutes.

The Poultry Cooking Table below provides detailed directions, Power Level, and Cooking Time settings for most cuts and types of poultry.

Poultry Cooking Table

POULTRY	POWER LEVEL	COOKING TIME	DIRECTIONS
Chicken pieces (2 1/2-3 lbs).	HI	4 1/2-5 1/2 minutes per pound	Wash, shake the water off, and go on with cooking. Place pieces in a single layer in a microwavable baking dish with thicker pieces to the outside. Brush with butter or browning agent and seasonings if desired. Cover with waxed paper. Cook until no longer pink and juices run clear. Let stand covered 5 minutes.
Chicken whole (3-3 1/2 lbs)	HI	12-13 minutes per pound	Wash, shake the water off, and go on with cooking. Place breast side down on a microwavable roast rack. Brush with butter, or browning agent and seasoning if desired. Cover with waxed paper. Cook 1/3 of estimated time. Turn breast side up, brush with butter, or browning agent. Replace waxed paper. Cook 1/3 of estimated time again. Shield if necessary. Cook remaining 1/3 of estimated time or until no longer pink and juices run clear. Let stand covered with foil 10 minutes. (The temperature may rise about 10°F.) The temperature in the high should be 180°F-185°F when the poultry is done.
Cornish Hens Whole (1-1 1/2 lbs. each)	HI	6-7 minutes per pound	Wash, shake the water off, and go on with cooking. Tie wings to body of hen and the legs to tail. Place hens breast side down on microwavable rack. Cover with waxed paper. Turn breast side up halfway through cooking. Shield bone ends of drumsticks with foil. Remove and discard drippings. Brush with butter or browning agent and seasonings if desired. Cook until no longer pink and juices run clear. Remove hens from microwave when they reach desired temperature. Let stand covered with foil 5 minutes. (Temperature may rise about 10°F). Temperature in breast should be 170°F before serving.

MAINTENANCE

CARE AND CLEANING

For best performance and safety, keep the oven clean inside and outside. Take special care to keep the inner door panel and the oven front frame free of food or grease build-up.

Never use rough powder or pads. Wipe the microwave oven inside and out, including the hood bottom cover, with a soft cloth and a warm (not hot) mild detergent solution. Then rinse and wipe dry. Use a chrome cleaner and polish on chrome, metal, and aluminum surfaces. Wipe spatters immediately with a wet paper towel, especially after cooking chicken or bacon. Clean your oven weekly or more often, if needed.

METAL RACK

Wash the metal rack with a mild soap and a soft or nylon scrub brush. Dry completely. Do not use abrasive scrubbers or cleaners to clean rack.

CLEANING THE GREASE FILTERS

The grease filter should be removed and cleaned often, at least once a month.

1. **Disconnect** power or **unplug** microwave oven.
2. **To remove grease filter, slide filter to the back.** Pull filter downward. The filter will drop out.

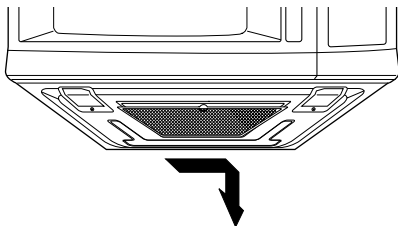

3. **Soak** grease filter in hot water and a mild detergent. **Scrub and swish** to remove embedded dirt and grease. **Rinse well and shake** to dry. **Do not clean filter with ammonia, corrosive cleaning agents such as lye-based oven cleaners, or place them in a dishwasher. The filter will turn black or could be damaged.**

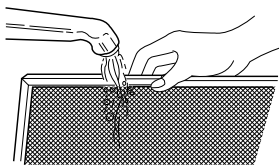

4. To reinstall the filter, slide it into the back slot, then push up to lock.

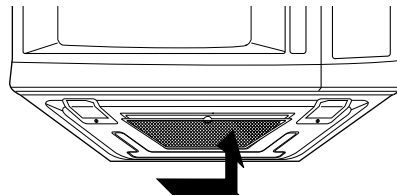

5. **Reconnect** power or **plug** in microwave oven. **NOTE: Do not** operate the hood without the filter in place.

CHARCOAL FILTER REPLACEMENT

If your oven is vented inside, the charcoal filter should be replaced every 6 to 12 months, and more often if necessary. The charcoal filter cannot be cleaned.

To order a new charcoal filter, contact the Parts Department at your nearest Authorized Service Center.

1. **Disconnect** power or **unplug** microwave oven.
2. **Remove** the two vent grille mounting screws.

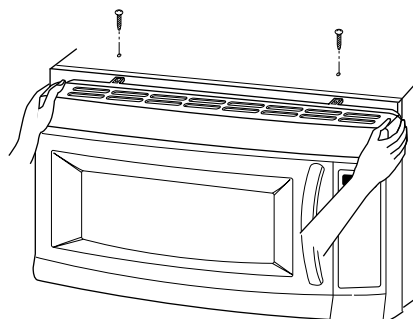

3. **Tip** the grille forward, then lift out to remove.
4. Remove old filter.

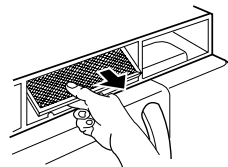

5. **Slide** a new charcoal filter into place. The filter should rest at the angle shown.

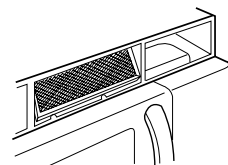

6. **Slide** the bottom of the vent grille into place. **Push** the top until it snaps into place. **Replace** the mounting screws.
7. **Reconnect** power or **plug** in microwave oven.

MAINTENANCE

COOKTOP/COUNTERTOP LIGHT REPLACEMENT

1. **Disconnect** power or **unplug** microwave oven.

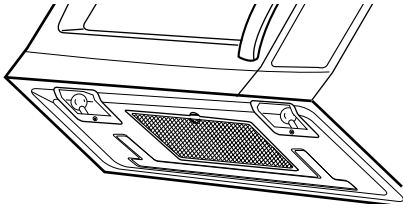

2. **Remove** the bulb cover mounting screws.
3. Replace bulb(s) with candelabra-base 35 watt bulb.
4. Replace bulb cover, and mounting screw.
5. **Reconnect** power or **plug** in microwave oven.

OVEN LIGHT REPLACEMENT

1. **Disconnect** power or **unplug** microwave oven.
2. **Remove** the vent grille mounting screws.
3. **Tip** the cover forward, then **lift out** to remove.

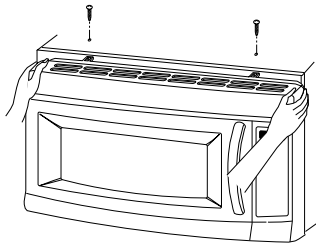

4. **Lift up** the bulb holder.

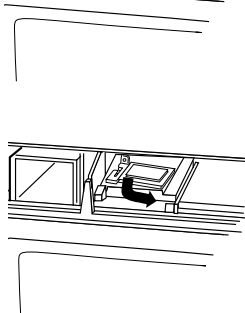
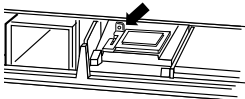

5. **Replace** bulb with a 30 watt bulb.
6. **Replace** the bulb holder, if damaged.
7. Slide the bottom of the vent grille into place. **Push** the bottom until it snaps into place. **Replace** the mounting screws.
8. **Reconnect** power or **plug** in microwave oven.

QUESTIONS AND ANSWERS

Q. Can I use a rack in my microwave oven so that I may reheat or cook in two levels at a time?

A. Only use the rack that is supplied with your microwave oven. Use of any other rack can result in poor cooking performance and/or arcing and may damage your oven.

Q. Can I use either metal or aluminum pans in my microwave oven?

A. Usable metal includes aluminum foil for shielding (use small, flat pieces), and shallow foil trays (if tray is 3/4 inch deep and filled with food to absorb microwave energy). Never allow metal to touch walls or door.

Q. Sometimes the door of my microwave oven appears wavy. Is this normal?

A. This appearance is normal and does not affect the operation of your oven.

Q. The glass tray does not moving.

A. • The glass tray is not correctly in place. It should be correct-side up and sitting firmly on the center hub.
• The support is not operating correctly. Remove the glass tray and restart the oven. Cooking without the glass tray can give you poor results.

Q. Why does the dish become hot when I microwave food in it? I thought that this should not happen.

A. As the food becomes hot it will conduct the heat to the dish. Use hot pads to remove food after cooking.

Q. What does standing time mean?

A. Standing time means that food should be taken out of the oven and covered for additional time after cooking. This process allows the cooking to finish, saves energy, and frees the oven for other purpose.

Q. Can I pop popcorn in my microwave oven? How do I get the best results?

A. Yes. Pop packaged microwave popcorn following manufacturer's guidelines or use the preprogrammed Popcorn pad. Do not use regular paper bags. Use the listening test by stopping the oven as soon as the popping slows to a pop every one or two seconds. Do not try to repop unpopped kernels. You can also use special microwave poppers. When using a popper, be sure to follow manufacturer's directions. Do not pop popcorn in glass utensils.

Q. Why does steam come out of the air exhaust vent?

A. Steam is normally produced during cooking. The microwave oven has been designed to vent this steam out the top vent.

MAINTENANCE

MICROWAVE UTENSIL GUIDE

USE	DO NOT USE
<p>OVENPROOF GLASS (treated for high intensity heat): utility dishes, loaf dishes, pie plates, cake plates, liquid measuring cups, casseroles and bowls without metallic trim.</p> <p>CHINA: bowls, cups, serving plates and platters without metallic trim.</p> <p>PLASTIC: Plastic wrap (as a cover)-- lay the plastic wrap loosely over the dish and press it to the sides. Vent plastic wrap by turning back one edge slightly to allow excess steam to escape. The dish should be deep enough so that the plastic wrap will not touch the food. As the food heats it may melt the plastic wrap wherever the wrap touches the food. Use plastic dishes, cups, semirigid freezer containers and plastic bags only for short cooking time. Use these with care because the plastic may soften from the heat of the food.</p> <p>PAPER: Paper towels, waxed paper, paper napkins, and paper plates with no metallic trim or design. Look for the manufacturer's label for use in the microwave oven.</p>	<p>METAL UTENSILS: Metal shields the food from microwave energy and produces uneven cooking. Also avoid metal skewers, thermometers or foil trays. Metal utensils can cause arcing, which can damage your microwave oven.</p> <p>METAL DECORATION: Metal-trimmed or metal-banded dinnerware, casserole dishes, etc. The metal trim interferes with normal cooking and may damage the oven.</p> <p>ALUMINUM FOIL: Avoid large sheets of aluminum foil because they hinder cooking and may cause harmful arcing. Use small pieces of foil to shield poultry legs and wings. Keep ALL aluminum foil at least 1 inch from the side walls and door of the oven.</p> <p>WOOD: Wooden bowls and boards will dry out and may split or crack when you use them in the microwave oven. Baskets react in the same way.</p> <p>TIGHTLY COVERED UTENSILS: Be sure to leave openings for steam to escape from covered utensils. Pierce plastic pouches of vegetables or other food items before cooking. Tightly closed pouches could explode.</p> <p>BROWN PAPER: Avoid using brown paper bags. They absorb too much heat and could burn.</p> <p>FLAWED OR CHIPPED UTENSILS: Any utensil that is cracked, flawed, or chipped may break in the oven.</p> <p>METAL TWIST TIES: Remove metal twist ties from plastic or paper bags. They become hot and could cause a fire.</p>

TROUBLESHOOTING

BEFORE CALLING FOR SERVICE

Check the following list to be sure a service call is really necessary. A quick reference of this manual as well as reviewing additional information on items to check may prevent an unneeded service call.

If nothing on the oven operates:

- check for a blown circuit fuse or a tripped main circuit breaker.
- check if oven is properly connected to electric circuit in house.
- check that controls are set properly.

If the oven interior light does not work:

- the light bulb is loose or defective.

If oven will not cook:

- check that control panel was programmed correctly.
- check that door is firmly closed.
- check that Start Pad was pressed.
- check that probe was inserted correctly into receptacle.
- check that timer wasn't started instead of a cook function.

If oven takes longer than normal to cook or cooks too rapidly:

- be sure the Power Level is programmed properly.

If the time of day clock does not always keep correct time:

- check that the power cord is fully inserted into the outlet receptacle.
- be sure the oven is the only appliance on the electrical circuit.

If food cooks unevenly:

- be sure food is evenly shaped.
- be sure food is completely defrosted before cooking.
- check placement of aluminum foil strips used to prevent overcooking.

If food is undercooked:

- check recipe to be sure all directions (amount, time, & power levels) were correctly followed.
- be sure microwave oven is on a separate circuit.
- be sure food is completely defrosted before cooking.

If food is overcooked:

- check recipe to be sure all directions (amount, power level, time, size of dish) were followed.

If arcing (sparks) occur:

- be sure microwavable dishes were used.
- be sure wire twist ties weren't used.
- be sure oven wasn't operated when empty.
- make sure metal rack (if used) is properly installed on 4 supports.

If the Display shows a time counting down but the oven is not cooking:

- check that door is firmly closed.
- check that timer wasn't started instead of a cooking function.

LG ELECTRONICS CANADA, INC.
GARANTIE LIMITÉE - Canada

GARANTIE : Si votre produit LG (le « produit ») s'avère défectueux en raison d'un défaut de matériau ou de fabrication lors d'une utilisation normale, pendant la période de garantie spécifiée ci-après, LG Canada réparera ou remplacera à sa discrétion le produit sur réception de la preuve d'achat originale fournie par le détaillant. Cette garantie n'est offerte qu'à l'acheteur original du produit chez un détaillant et ne s'applique qu'à un produit distribué au Canada par LG Canada ou par un distributeur canadien autorisé. La garantie ne s'applique qu'aux produits situés et utilisés au Canada.

PÉRIODE DE GARANTIE : (Remarque : Si la date d'achat originale ne peut être vérifiée, la garantie débutera soixante (60) jours suivant la date de fabrication.)	
Four-hotte / micro-ondes à convection / micro-ondes encastré / tout four à micro-ondes	Garantie prolongée sur les pièces seulement
Un (1) an à compter de la date d'achat initiale	Cinq (5) ans à compter de la date d'achat initiale
Pièces et main-d'œuvre (service à domicile; four-hotte et micro-ondes à convection) (pièces internes fonctionnelles seulement)	Magnétron seulement

- ⊗ Les produits et pièces de remplacement sont garantis pour la portion restante de la période de garantie originale ou quatre-vingt-dix (90) jours, selon la période la plus longue.
- ⊗ Les produits et pièces de remplacement peuvent être neufs ou remanufacturés.
- ⊗ Le centre de service autorisé LG garantit les réparations pendant trente (30) jours.

LA RESPONSABILITÉ DE LG CANADA SE LIMITE À LA GARANTIE CI-DESSUS. SAUF TEL QU'IL EST EXPLICITEMENT INDIQUÉ CI-DESSUS, LG CANADA NE FOURNIT AUCUNE AUTRE GARANTIE ET REJETTE TOUTES LES AUTRES GARANTIES ET CONDITIONS EXPLICITES OU IMPLICITES À L'ÉGARD DU PRODUIT, CE QUI INCLUT, SANS TOUTEFOIS S'Y LIMITER, TOUTE GARANTIE ET CONDITION IMPLICITE DE QUALITÉ MARCHANDE OU DE CONVENANCE À UN USAGE PARTICULIER ET AUCUNE DÉCLARATION NE LIERA LG CANADA. LG CANADA N'AUTORISE PERSONNE À CRÉER NI À ASSUMER AUCUNE AUTRE PROVISION POUR GARANTIES EN RELATION AVEC CE PRODUIT. SI UNE GARANTIE OU CONDITION IMPLICITE EST REQUISE PAR LA LOI, SA PÉRIODE SE LIMITE À CELLE DE LA GARANTIE EXPLICITE SUSMENTIONNÉE.

LG CANADA, LE FABRICANT ET LE DISTRIBUTEUR NE POURRONT ÊTRE TENUS RESPONSABLES D'AUCUN DOMMAGE ACCESSOIRE, CONSÉCUTIF, SPÉCIAL, DIRECT OU INDIRECT, D'AUCUNE PERTE D'ACHALANDAGE OU DE PROFITS, D'AUCUN DOMMAGE PUNITIF, EXEMPLAIRE OU AUTRE, DIRECTEMENT OU INDIRECTEMENT ATTRIBUABLE À TOUTE VIOLATION CONTRACTUELLE, FONDAMENTALE OU AUTRE, OU À UNE ACTION, UNE OMISSION, UN DÉLIT OU TOUTE AUTRE CHOSE.

La présente garantie vous confère des droits légaux spécifiques. Vous pourriez disposer d'autres droits, suivant les lois provinciales applicables. Toute clause de la présente garantie qui invalide ou modifie une condition ou garantie implicite aux termes d'une loi provinciale est dissociable si elle entre en conflit avec la loi provinciale, et ce, sans affecter les autres clauses de la garantie.

LA PRÉSENTE GARANTIE LIMITÉE NE COUVRE PAS CE QUI SUIT :

1. Un appel de service pour livrer, ramasser ou installer le produit; renseigner un client sur le fonctionnement du produit; réparer ou remplacer des fusibles ou rectifier le câblage; ou corriger une réparation ou installation non autorisée.
2. La défaillance du produit durant une panne ou interruption de courant ou en raison d'un service électrique inadéquat.
3. Des dommages occasionnés par la fuite ou le bris de conduites d'eau, le gel de conduites d'eau, des tuyaux de drainage restreints, une alimentation en eau inadéquate ou interrompue ou une alimentation en air inadéquate.
4. Des dommages attribuables à l'utilisation du produit dans une atmosphère corrosive ou contraire aux instructions spécifiées dans le manuel d'utilisation du produit.
5. Des dommages au produit causés par un accident, des animaux nuisibles ou des vermines, la foudre, le vent, un incendie, une inondation ou une catastrophe naturelle.
6. Les dommages attribuables à une mauvaise utilisation, une utilisation abusive ou à une installation, une réparation ou un entretien inapproprié du produit. Les réparations inappropriées incluent l'utilisation de pièces ni approuvées ni recommandées par LG Canada.
7. La détérioration ou la défaillance du produit causée par une modification ou un changement non autorisé ou une utilisation autre que celle prévue, ou résultant d'une fuite d'eau occasionnée par une mauvaise installation.
8. La détérioration ou la défaillance du produit causée par un courant ou un voltage électrique incorrect, une utilisation commerciale ou industrielle, ou l'utilisation d'accessoires, d'éléments ou de produits nettoyants non approuvés par LG Canada.
9. Les dommages causés par le transport et la manipulation, notamment les égratignures, les bosses, les écaillures et/ou tout autre dommage à la finition du produit, à moins que ces dommages ne soient attribuables à des défauts de matériaux ou de fabrication et qu'ils ne soient signalés dans un délai d'une (1) semaine de la livraison.
10. Des dommages ou des pièces manquantes à tout produit exposé, déballé, soldé ou remis à neuf.
11. Des produits dont le numéro de série original a été retiré, modifié ou ne peut être facilement déterminé. Le modèle et le numéro de série, ainsi que le reçu de vente original du détaillant, sont requis pour valider la garantie.
12. L'augmentation des coûts et de la consommation des services publics.
13. Le remplacement des ampoules électriques, des filtres et de toute pièce non durable.
14. Les réparations requises si le produit ne sert pas à une utilisation domestique normale et habituelle (y compris, sans toutefois s'y limiter, une utilisation commerciale, dans un bureau ou un centre récréatif) ou est utilisé contrairement aux instructions spécifiées dans le manuel d'utilisation du produit.
15. Les coûts associés à l'enlèvement du produit de votre résidence aux fins de réparation.
16. L'enlèvement et la réinstallation du produit, s'il est installé à un endroit inaccessible ou contrairement aux instructions d'installation publiées, y compris dans le manuel d'utilisation et le manuel d'installation du produit.
17. Les accessoires du produit, tels que les balconnets, les tiroirs, les poignées, les tablettes, etc. Sont également exclues les pièces non incluses initialement avec le produit.

Tous les coûts associés aux circonstances exclues ci-dessus seront assumés par le consommateur.

Pour obtenir tous les détails sur la garantie et accéder au service à la clientèle, téléphonez-nous ou visitez notre site Web :

Écrivez vos renseignements de garantie ci-dessous :

Composez le 1-888-542-2623 (24 h sur 24, 365 jours par année) et sélectionnez l'option de menu appropriée, ou visitez notre site Web au <http://www.lg.ca>

Renseignements sur l'enregistrement du produit :

Modèle :

Numéro de série :

Date d'achat :