



LG
Life's Good

LCD TV OWNER'S MANUAL

LCD TV MODELS

32LF57 **

42LF57 **

32LH57 **

42LH57 **

Please read this manual carefully before operating your TV. Retain it for future reference. Record model number and serial number of the TV. Refer to the label on the back cover and quote this information to your dealer when requiring service.

Model :

Serial No. :



**Digital Video
Broadcasting**

Trade Mark of the DVB Digital Video
Broadcasting Project (1991 to 1996)

ID Number(s) : 6950 : 32LF5700
6951 : 42LF5700
6952 : 32LH5700
6953 : 42LH5700

ACCESSORIES

Ensure that the following accessories are included with your TV. If an accessory is missing, please contact the dealer where you purchased the TV.

- Image shown may differ from your TV



Owner's Manual

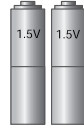

Batteries



Power Cord



Remote Control

This item is not included for all models.

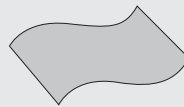

*** Lightly wipe any stains or fingerprints on the surface of the TV with the polishing cloth.**

Polishing Cloth Polishing cloth for use on the screen.

Do not use excessive force. This may cause scratching or discolouration.

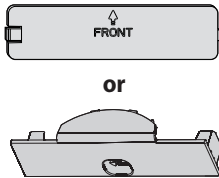

Protection Cover
(Refer to p.11)

(Only 32/42LF57**)

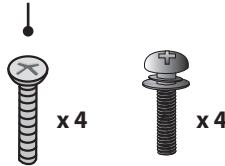

Bolts for stand assembly
(Refer to p.7)



1-screw for stand fixing
(Refer to p.8)

Wall Mounting Bracket (Seperate purchase)

RW230

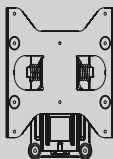

32LF57**
32LH57**

AW-47LG30M

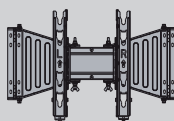

32/42LF57**
32/42LH57**



HDMI, the HDMI logo and High-Definition Multimedia Interface are trademarks or registered trademarks of HDMI Licensing LLC.

CONTENTS

ACCESSORIES

PREPARATION

Front Panel Controls	4
Back Panel Information	6
Stand Installation	7
Desktop Pedestal Installation	8
Attaching the TV to a Desk	8
Careful installation advice	9
Back Cover for Wire Arrangement	10
Swivel Stand	11
Not Using the Desk-Type Stand	11
Wall Mount: Horizontal Installation	12
Antenna Connection	13

EXTERNAL EQUIPMENT SETUP

HD Receiver Setup	14
DVD Setup	16
VCR Setup	18
Insertion of CI Module	20
Digital Audio Out Setup	20
headphone setup	20
Other A/V Source Setup	21
USB Setup	21
PC Setup	22

WATCHING TV / PROGRAMME CONTROL

Remote Control Key Functions	28
Turning On The TV	30
Programme Selection	30
Volume Adjustment	30
CI+ CAM	31
Quick Menu	33
On Screen Menus Selection and Adjustment	34
Antenna Auto Programme Tuning	35
Antenna Manual Programme Tuning (In Digital Mode)	36
Antenna Manual Programme Tuning (In Analogue Mode)	37
Satellite Tuning (LNB Only)	39
Satellite Tuning (DiSEqC)	40
Programme Edit	41
Software Update	43
Diagnostics	46
CI Information (In Digital Mode Only)	47
Selecting the Programme List	48
Input List	49
Input Label	50
AV Mode	50
Multifeed	51
Initializing (Reset to original factory settings)	52

TO USE A USB DEVICE

Photo List	54
Music List	58

TV GUIDE (EPG; ELECTRONIC PROGRAMME GUIDE) (In Digital Mode)

PICTURE CONTROL

Picture Size (Aspect Ratio) Control	65
Energy Saving	67
Preset Picture Settings - Picture Mode	68
Manual Picture Adjustment - User Mode	69
Picture Improvement Technology	70
Picture Reset	72
Demo Mode (Only 32LH57**/42LF57**/42LH57**)	73
Mode Setting	74

SOUND & LANGUAGE CONTROL

Auto Volume Leveler	75
Preset Sound Settings - Sound Mode	76
Manual Sound Setting Adjustment - User Mode	77
SRS Trusurround XT	77
Balance	78
TV Speakers On/Off Setup	79
Selecting Digital Audio Out	80
Audio Reset	81
I/II	82
Language Selection	84

TIME SETTING

Clock Setup	85
Auto On/Off Time Setting	86
Auto Shut-Off Setting	87
Sleep Timer Setting	87
Time Zone Setting	88

PARENTAL CONTROL / RATINGS

Set Password & Lock System	89
Block Programme	90
Parental Control (In Digital Mode Only)	91
Key Lock	92

TELETEXT

Switch On/Off	93
Simple Text	93
Fastext	93
Special Teletext Functions	94

APPENDIX

Troubleshooting	95
Maintenance	96
Product Specifications	97
Open Source License	98

PREPARATION

FRONT PANEL CONTROLS

32/42LF57**

PREPERATION

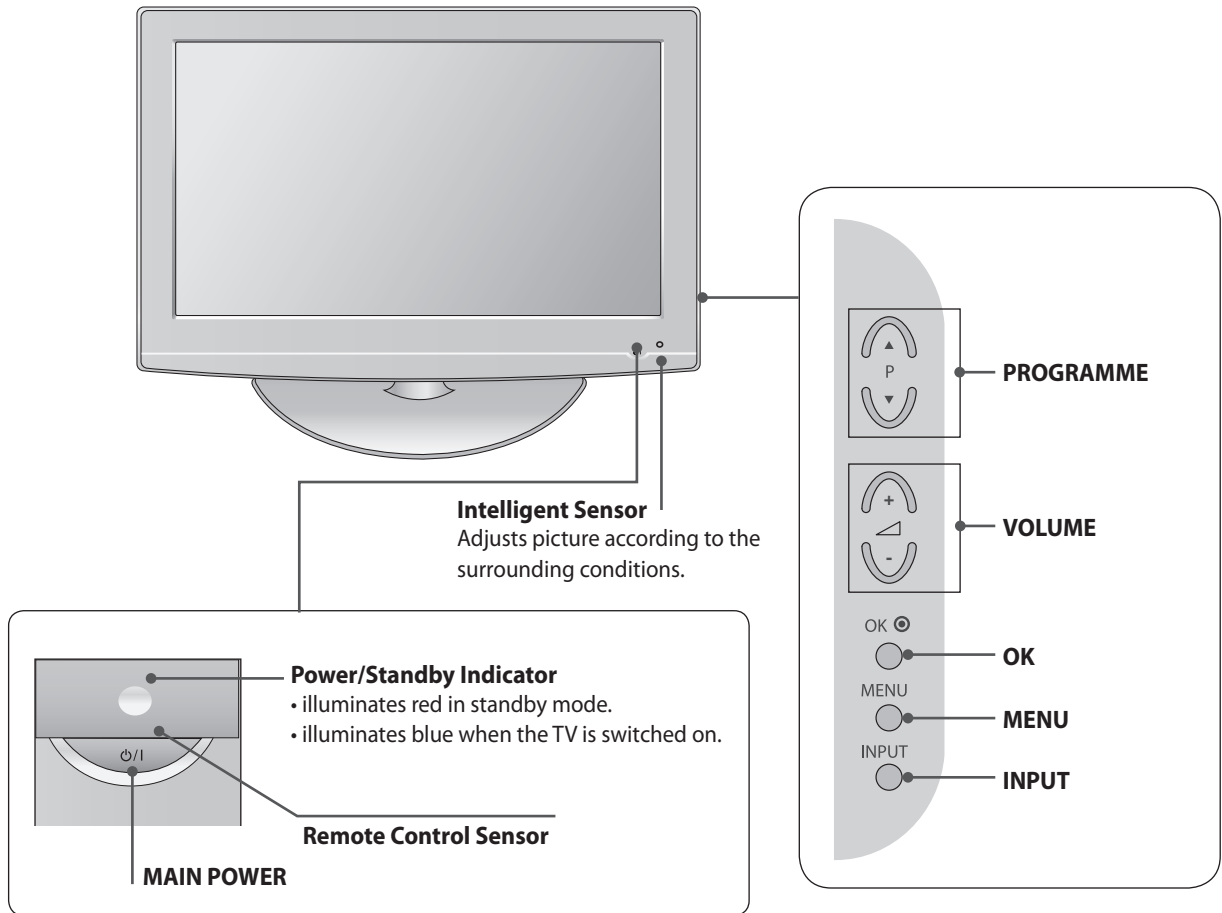

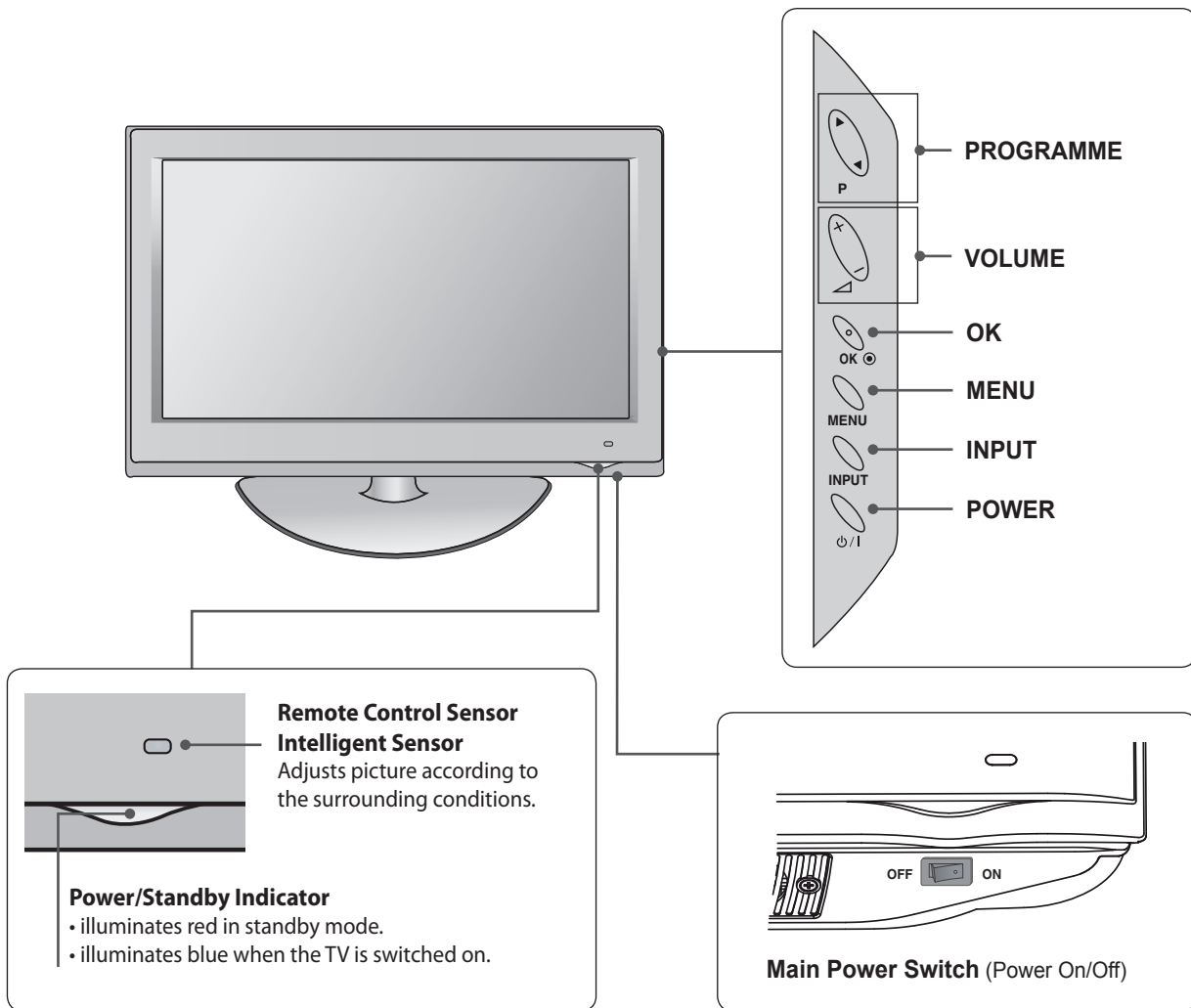

PREPARATION

BACK PANEL INFORMATION

- Image shown may differ from your TV.

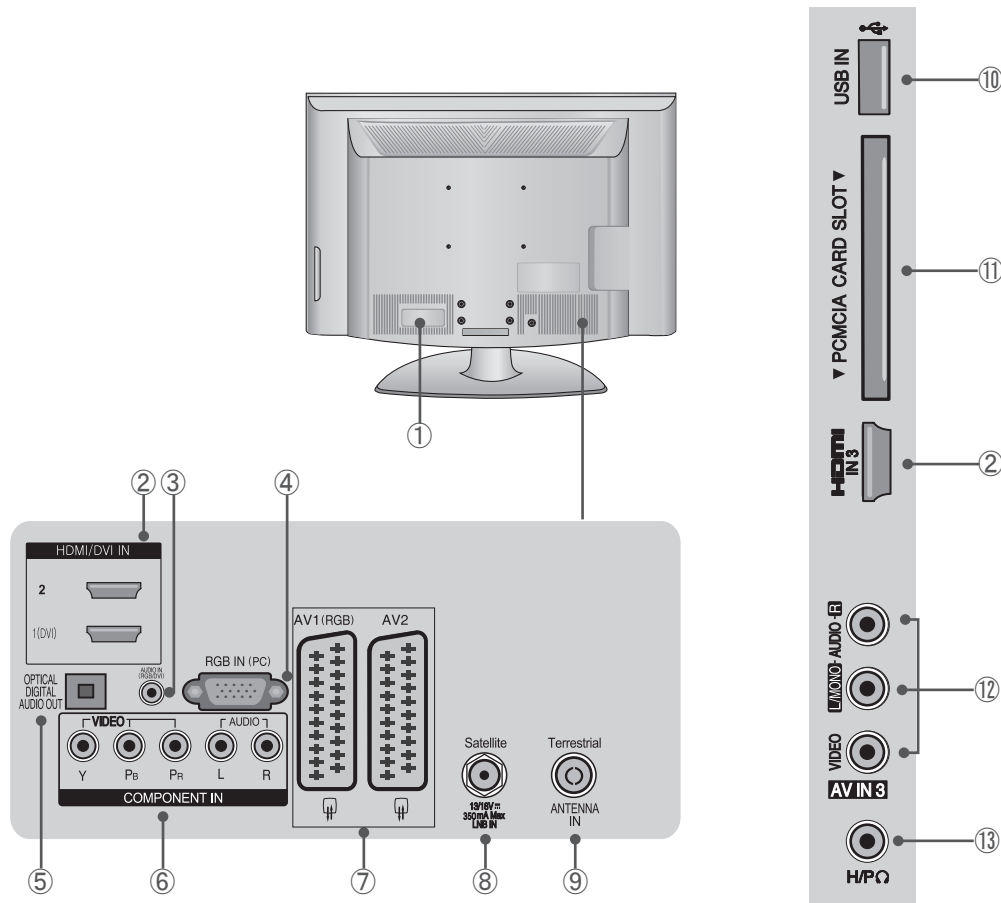

① Power Cord Socket

This TV operates on an AC power. The voltage is indicated on the Specifications page. Never attempt to operate the TV on DC power.

② HDMI/DVI IN Input

Connect an HDMI signal to HDMI IN. Or DVI(VIDEO) signal to HDMI/DVI port with DVI to HDMI cable.

③ RGB/DVI Audio Input

Connect the audio from a PC or HDMI1 (DVI).

④ RGB IN Input

Connect the output from a PC.

⑤ OPTICAL DIGITAL AUDIO OUT

Connect digital audio to various types of equipment. Connect to a Digital Audio Component. Use an Optical audio cable. Note: In standby mode, these ports do not work.

⑥ Component Input

Connect a component video/audio device to these jacks.

⑦ Euro Scart Socket (AV1/AV2)

Connect scart socket input or output from an external device to these jacks.

⑧ Satellite LNB Input

Connect a satellite antenna cable.

⑨ Antenna Input

Connect a RF antenna or cable to this jack.

⑩ USB Input

Connect USB storage device to this jack. (for MP3 or JPEG files)

⑪ PCMCIA (Personal Computer Memory Card International Association) Card Slot

Insert the CI Module to PCMCIA CARD SLOT. (This feature is not available in all countries.)

⑫ Audio/Video Input

Connect audio/video output from an external device to these jacks.

⑬ Headphone Socket

Plug the headphone into the headphone socket.

STAND INSTALLATION

- Image shown may differ from your TV.

When assembling the desk type stand, check whether the bolt is fully tightened. (If not tightened fully, the product can tilt forward after the product installation.) If you tighten the bolt with excessive force, the bolt can deviate from abrasion of the tightening part of the bolt.

Only 32/42LF57**

- 1 Carefully place the TV screen side down on a cushioned surface to protect the screen from damage.

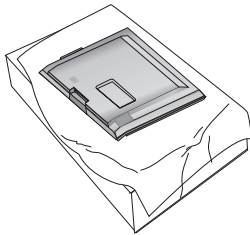

- 2 Assemble the parts of the **Stand Body** with the **Stand Base** of the TV.

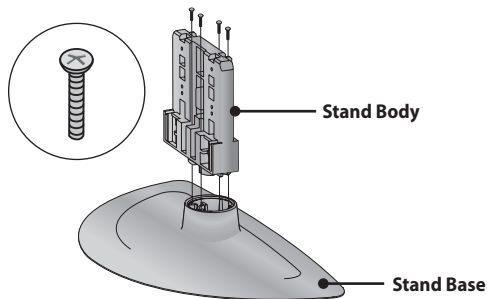

- 3 Assemble the TV as shown.

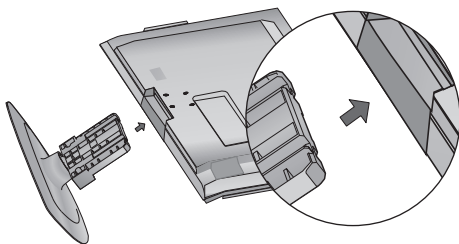

- 4 Fix the 4 bolts securely using the holes in the back of the TV.

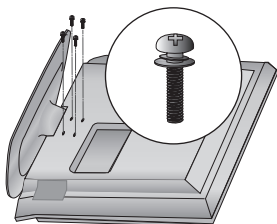

Only 32/42LH57**

- 1 Carefully place the TV screen side down on a cushioned surface to protect the screen from damage.

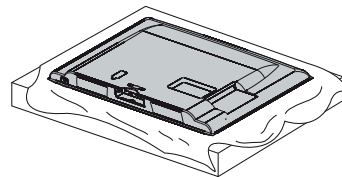

- 2 Assemble the TV as shown.

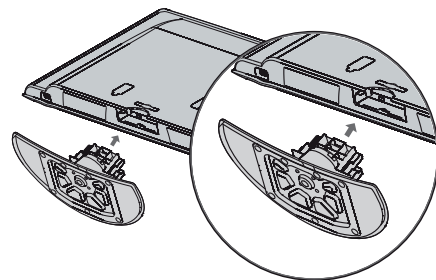

- 3 Fix the 4 bolts securely using the holes in the back of the TV.

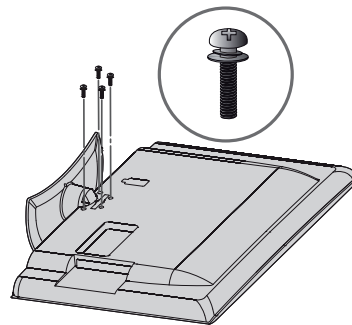

PREPARATION

DESKTOP PEDESTAL INSTALLATION

For adequate ventilation allow a clearance of 4" (10cm) all around the TV.

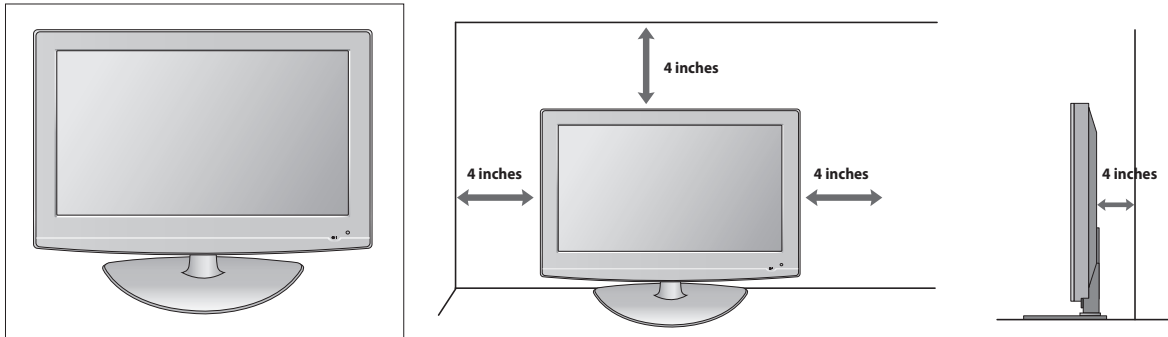

PREPERATION

ATTACHING THE TV TO A DESK

The TV must be attached to desk so it cannot be pulled in a forward/backward direction, potentially causing injury or damaging the product. Use only an attached screw.

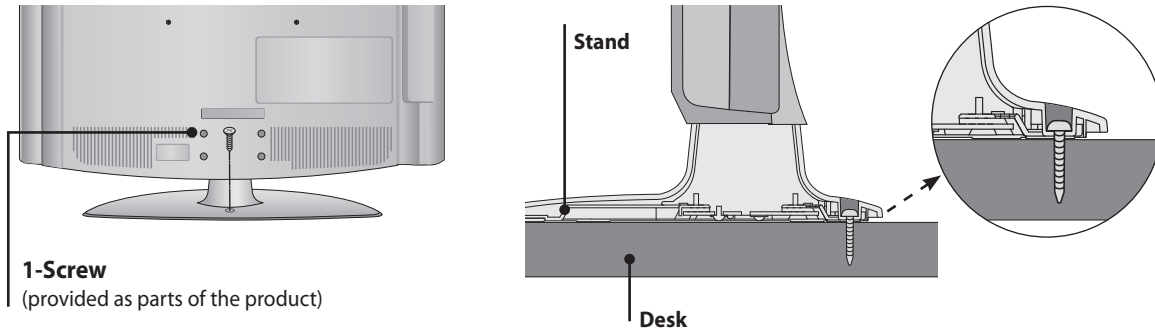

WARNING

- ▶ To prevent TV from falling over, the TV should be securely attached to the floor/wall per installation instructions. Tipping, shaking, or rocking the machine may cause injury.

CAREFUL INSTALLATION ADVICE

- You should purchase necessary components to fix the TV safely and secure to the wall on the market.
- Position the TV close to the wall to avoid the possibility of it falling when pushed.
- The instructions shown below are a safer way to set up the TV, by fixing it to the wall, avoiding the possibility of it falling forwards if pulled. This will prevent the TV from falling forward and causing injury. This will also prevent the TV from damage. Ensure that children do not climb or hang from the TV.

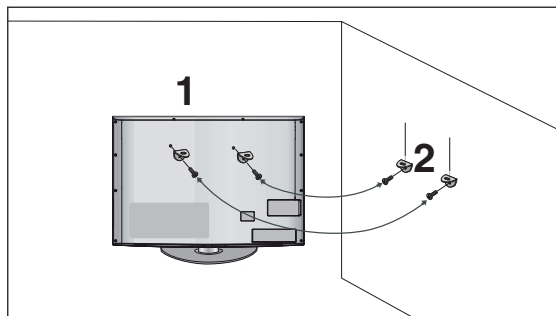

- 1 Use the eye-bolts or TV brackets/bolts to fix the product to the wall as shown in the picture.
(If your TV has bolts in the eye-bolts, loosen these bolts.)
* Insert the eye-bolts or TV brackets/bolts and tighten them securely in the upper holes.
- 2 Secure the wall brackets with the bolts on the wall. Match the height of the bracket that is mounted on the wall.

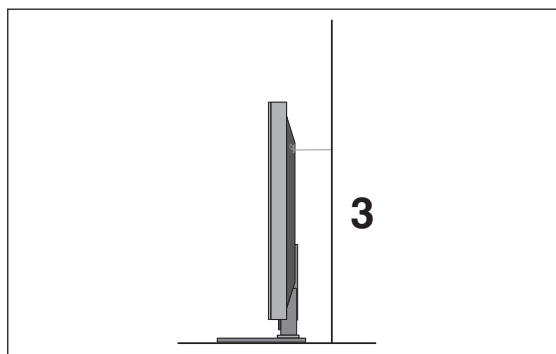

- 3 Use a sturdy rope to tie the product for alignment. It is safer to tie the rope so it becomes horizontal between the wall and the product.

NOTE

- ▶ When moving the TV undo the cords first.
- ▶ Use a platform or cabinet strong and large enough to support the size and weight of the TV.
- ▶ To use the TV safely make sure that the height of the bracket on the wall and on the TV is the same.

PREPARATION

BACK COVER FOR WIRE ARRANGEMENT

- Image shown may differ from your TV.

- ① Connect the cables as necessary.
To connect additional equipment, see the **External Equipment Setup** section.

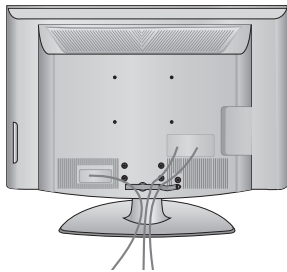

- ② Install the **CABLE MANAGEMENT CLIP** as shown.

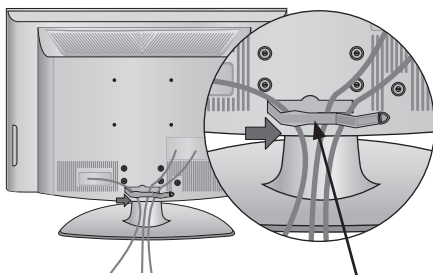

CABLE MANAGEMENT CLIP

- ③ Fit the **CABLE MANAGEMENT CLIP** as shown.

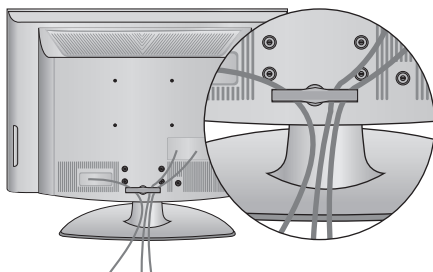

NOTE

- ▶ Do not use the **CABLE MANAGEMENT CLIP** to lift the TV.
- If the TV is dropped, you may be injured or the TV may be damaged.

SWIVEL STAND

- Image shown may differ from your TV.

After installing the TV, you can adjust the TV manually to the left or right direction by 20 degrees to suit your viewing position.

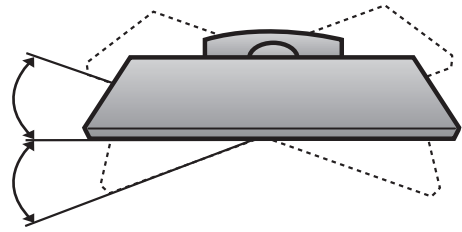

NOT USING THE DESK-TYPE STAND

- Image shown may differ from your TV.

When installing the wall-mounted unit, use the protection cover.

Only 32/42LF57**

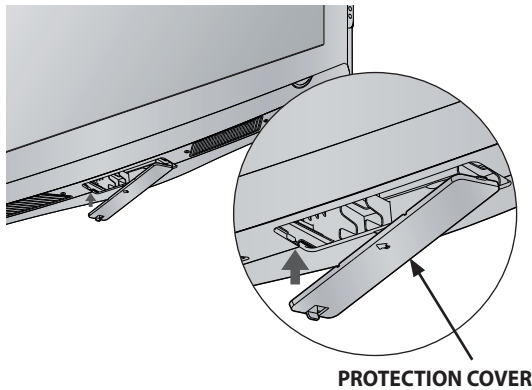

Only 32/42LH57**

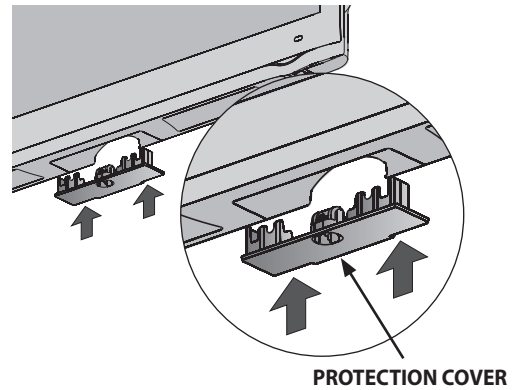

Insert the **PROTECTION COVER** into the TV until clicking sound.

PREPARATION

- The TV can be installed in various ways such as on a wall, or on a desktop etc.
- The TV is designed to be mounted horizontally.

EARTHING

Ensure that you connect the earth wire to prevent possible electric shock. If grounding methods are not possible, have a qualified electrician install a separate circuit breaker. Do not try to earth the TV by connecting it to telephone wires, lightening rods or gas pipes.

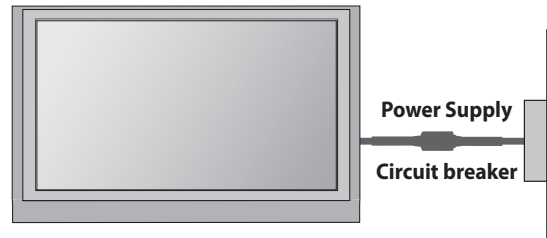

PREPERATION

WALL MOUNT: HORIZONTAL INSTALLATION

- We recommend the use of a LG Brand wall mounting bracket when mounting the TV to a wall.
- We recommend that you purchase a wall mounting bracket which supports VESA standard.
- LG recommends that wall mounting be performed by a qualified professional installer.

NOTE

- ▶ Should Install wall mount on a solid wall perpendicular to the floor.
- ▶ Should use a special wall mount, if you want to install it to ceiling or slanted wall.
- ▶ The surface that wall mount is to be mounted on should be of sufficient strength to support the weight of TV set; e.g. concrete, natural rock, brick and hollow block.
- ▶ Installing screw type and length depends on the wall mount used. Further information, refer to the instructions included with the mount.
- ▶ LG is not liable for any accidents or damage to property or TV due to incorrect installation:
 - Where a non-compliant VESA wall mount is used.
 - Incorrect fastening of screws to surface which may cause TV to fall and cause personal injury.
 - Not following the recommended Installation method.

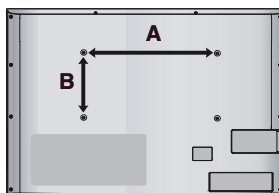
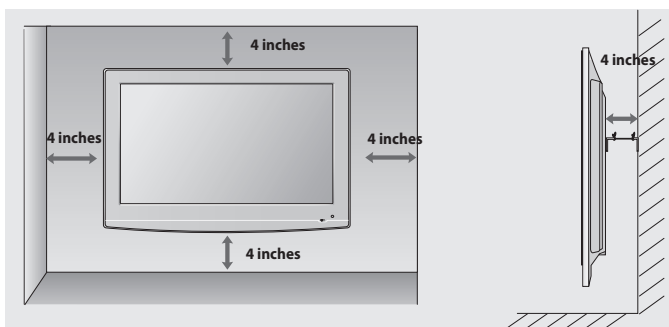

Model	VESA (A * B)	Standard Screw	Quantity
32LF57**/32LH57**	200 * 100	M4	4
42LF57**/42LH57**	200 * 200	M6	4

- To prevent damage do not connect to the mains outlet until all connections are made between the devices.

ANTENNA CONNECTION

- For optimum picture quality, adjust antenna direction.
- An antenna cable and converter are not supplied.

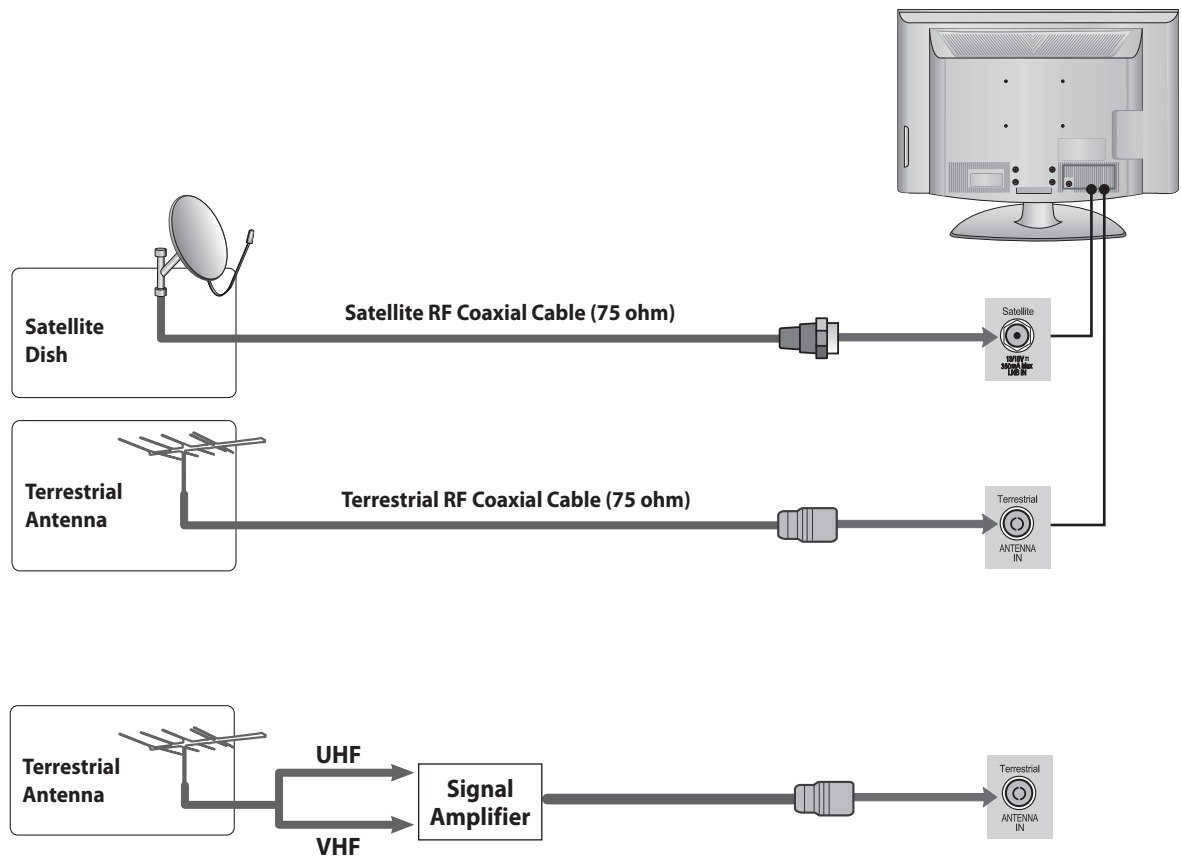

- In poor signal areas, to achieve better picture quality it may be necessary to install a signal amplifier to the antenna as shown above.
- If signal needs to be split for two TVs, use an antenna signal splitter for connection.

EXTERNAL EQUIPMENT SETUP

- To avoid damaging any equipment, never plug in any power cord until you have finished connecting all equipment.
- Image shown may differ from your TV.

HD RECEIVER SETUP

- This TV can receive Digital RF/Cable signals without an external digital set-top box. However, if you do receive Digital signals from a digital set-top box or other digital external device, refer to the diagram as shown below.

Connecting with a Component Cable

- 1 Connect the video outputs (Y, P_b, P_r) of the digital set top box to the **COMPONENT IN VIDEO** jacks on the TV.
- 2 Connect the audio outputs of the digital set-top box to the **COMPONENT IN AUDIO** jacks on the TV.
- 3 Turn on the digital set-top box. (Refer to the owner's manual for the digital set-top box.)
- 4 Select **Component** input source using the **INPUT** button on the remote control.

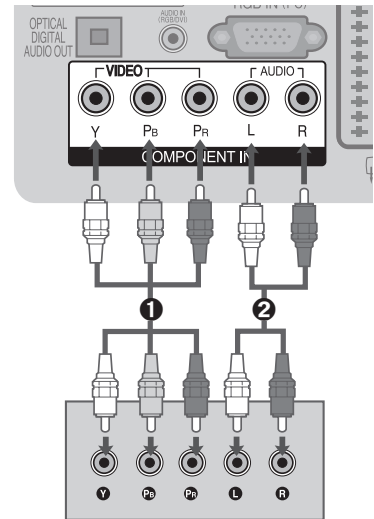

EXTERNAL EQUIPMENT SETUP

Signal	Component	HDMI
480i/576i	O	X
480p/576p	O	O
720p/1080i	O	O
1080p	O (50/60Hz only)	O (24Hz/30Hz/50Hz/60Hz)

Connecting with an HDMI Cable

- 1 Connect the digital set-top box to **HDMI/DVI IN 1**, **HDMI IN 2** or **HDMI IN 3** jack on the TV.
- 2 Turn on the digital set-top box.
(Refer to the owner's manual for the digital set-top box.)
- 3 Select **HDMI1**, **HDMI2** or **HDMI3** input source using the **INPUT** button on the remote control.

NOTE

- ▶ Check that your HDMI cable is version 1.3 or higher. If the HDMI cables don't support HDMI version 1.3, flickering or no screen display can result. Please use the latest cables that support at least HDMI version 1.3.

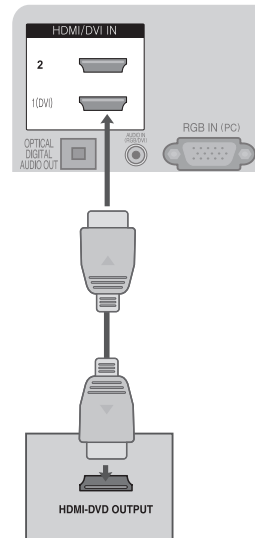

Connecting with an HDMI to DVI Cable

- 1 Connect the digital set-top box to **HDMI/DVI IN 1** jack on the TV.
- 2 Connect the audio output of the digital set-top box to the **AUDIO IN (RGB/DVI)** jack on the TV.
- 3 Turn on the digital set-top box.
(Refer to the owner's manual for the digital set-top box.)
- 4 Select **HDMI 1** input source using the **INPUT** button on the remote control.

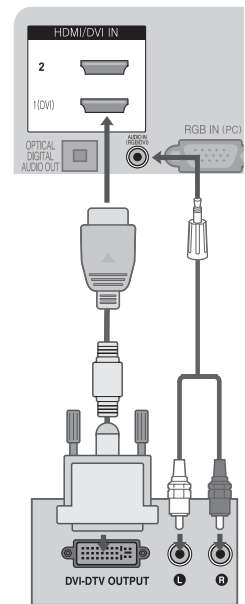

EXTERNAL EQUIPMENT SETUP

DVD SETUP

Connecting with a Component Cable

- 1 Connect the video outputs (Y, P_B, P_R) of the DVD to the **COMPONENT IN VIDEO** jacks on the TV.
- 2 Connect the audio outputs of the DVD to the **COMPONENT IN AUDIO** jacks on the TV.
- 3 Turn on the DVD player, insert a DVD.
- 4 Select **Component** input source using the **INPUT** button on the remote control.
- 5 Refer to the DVD player's manual for operating instructions.

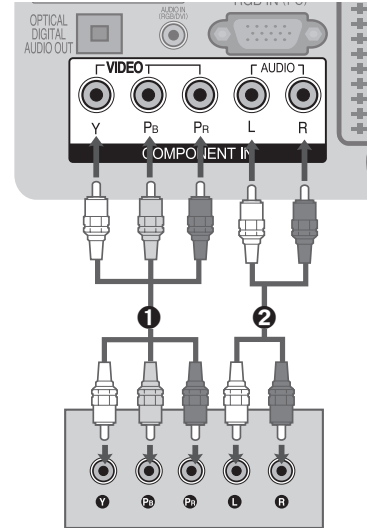

Component Input Ports

To achieve better picture quality, connect a DVD player to the component input ports as shown below.

Component ports on the TV	Y	P _B	P _R
Video output ports on DVD player	Y	P _B	P _R
	Y	B-Y	R-Y
	Y	C _b	C _r
	Y	P _b	P _r

Connecting the HDMI Cable

- 1 Connect the HDMI output of the DVD to the **HDMI/DVI IN 1**, **HDMI IN 2** or **HDMI IN 3** jack on the TV.
- 2 Select **HDMI1**, **HDMI2** or **HDMI3** input source using the **INPUT** button on the remote control.
- 3 Refer to the DVD player's manual for operating instructions.

NOTE

- ▶ The TV can receive video and audio signals simultaneously when using a HDMI cable.
- ▶ If the DVD does not support Auto HDMI, you must set the output resolution appropriately.
- ▶ Check that your HDMI cable is version 1.3 or higher. If the HDMI cables don't support HDMI version 1.3, flickering or no screen display can result. Please use the latest cables that support at least HDMI version 1.3.

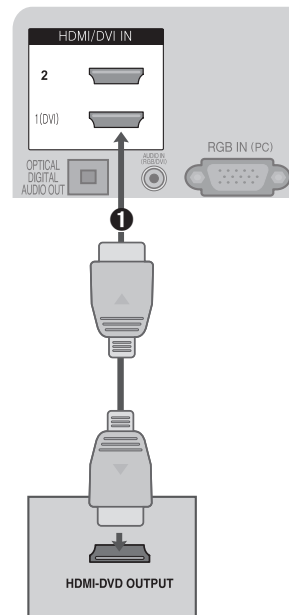

Connecting with a Euro Scart Cable

- ❶ Connect the Euro scart socket of the DVD to the **AV1** Euro scart socket on the TV.
- ❷ Turn on the DVD player, insert a DVD.
- ❸ Select **AV1** input source using the **INPUT** button on the remote control.
If connected to **AV2** Euro scart socket, select **AV2** input source.
- ❹ Refer to the DVD player's manual for operating instructions.

NOTE

- ▶ Any Euro scart cable used must be signal shielded.

Copy-protected programmes will not be output on the EURO scart sockets for legal reasons. Even if it was output, the video signals fed through the EURO scart sockets will be not recorded by copyright protection systems.

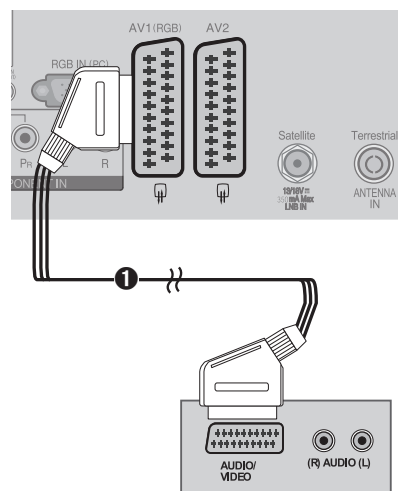

Scart Output

Main Input		AV1 (SCART1 Output)	AV2 (SCART2 Output)
TV	Satellite TV	Mute	Satellite TV
	Digital TV	Mute	Digital TV
	Analogue TV	Analogue TV	Analogue TV
AV1 (SCART1)	CVBS	Mute (Analogue TV if the TV mode you last watched is Analogue mode.)	AV1 (CVBS)
	RGB		AV2 (CVBS)
AV2 (SCART2)	CVBS		AV3 (CVBS)
AV3 (CVBS Side)			Mute
Component			Mute
RGB			Mute
HDMI1			Mute
HDMI2			Mute
HDMI3 (Side)			Mute

EXTERNAL EQUIPMENT SETUP

VCR SETUP

To avoid picture noise (interference), allow adequate distance between the VCR and TV.

Connecting with a RF Cable

- 1 Connect the **ANT OUT** socket of the VCR to the **ANTENNA IN** socket on the TV.
- 2 Connect the terrestrial antenna cable to the **ANT IN** socket of the VCR.
- 3 Press the **PLAY** button on the VCR and match the appropriate channel between the TV and VCR for viewing.

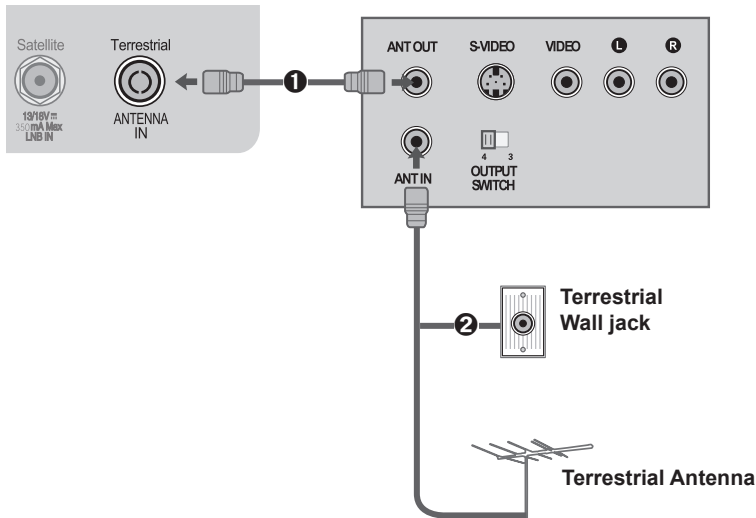

Connecting with a RCA Cable

- 1 Connect the **AUDIO/VIDEO** jacks between TV and VCR. Match the jack colours (Video = yellow, Audio Left = white, and Audio Right = red)
- 2 Insert a video tape into the VCR and press PLAY on the VCR. (Refer to the VCR owner's manual.)
- 3 Select **AV3** input source using the **INPUT** button on the remote control.

NOTE

- ▶ If you have a mono VC R, connect the audio cable from the VCR to the **AUDIO L/MONO** jack of the TV.

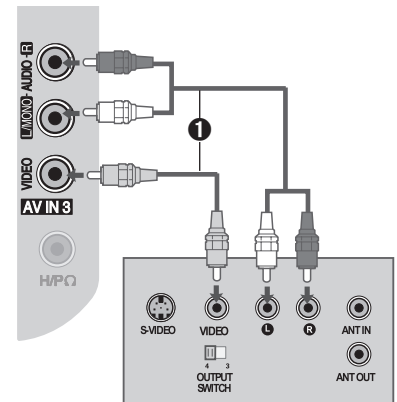

Connecting with a Euro Scart Cable

- ❶ Connect the Euro scart socket of the VCR to the **AV1** Euro scart socket on the TV.
- ❷ Insert a video tape into the VCR and press PLAY on the VCR.
(Refer to the VCR owner's manual.)
- ❸ Select **AV1** input source using the **INPUT** button on the remote control.
- ❹ If connected to **AV2** Euro scart socket, select **AV2** input source.

NOTE

- ▶ Any Euro Scart cable used must be signal shielded.
- ▶ Copy-protected programmes will not be output on the EURO scart sockets for legal reasons. Even if it was output, the video signals fed through the EURO scart sockets will not be recorded by copyright protection systems.

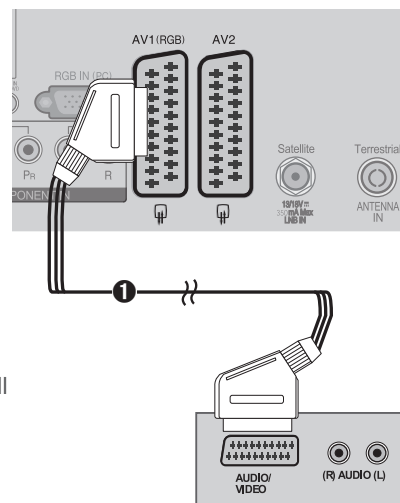

Scart Output

Main Input		AV1 (SCART1 Output)	AV2 (SCART2 Output)
TV	Satellite TV	Mute	Satellite TV
	Digital TV	Mute	Digital TV
	Analogue TV	Analogue TV	Analogue TV
AV1 (SCART1)	CVBS	Mute (Analogue TV if the TV mode you last watched is Analogue mode.)	AV1 (CVBS)
	RGB		AV2 (CVBS)
AV2 (SCART2)	CVBS		AV3 (CVBS)
AV3 (CVBS Side)			Mute
Component			Mute
RGB			Mute
HDMI1			Mute
HDMI2			Mute
HDMI3 (Side)			Mute

EXTERNAL EQUIPMENT SETUP

INSERTION OF CI MODULE

- To view the encrypted (pay) services in digital TV mode.
- This feature is not available in all countries.

- 1 Insert the CI Module to **PCMCIA** (Personal Computer Memory Card International Association) **CARD SLOT** of TV as shown. For further information, see p.47.

NOTE

- ▶ Check if the CI module is inserted into the PCMCIA card slot in the right direction. If the module is not inserted properly, this can cause damage to the TV and the PCMCIA card slot.

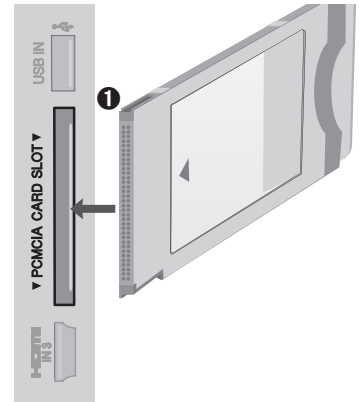

DIGITAL AUDIO OUT SETUP

Sending the TV's digital audio signal to external audio equipment via the Digital Audio Output (Optical) port.

If you want to enjoy digital broadcasting through 5.1-channel speakers, connect the **OPTICAL DIGITAL AUDIO OUT** terminal on the back of TV to a Home Theater (or amp).

- 1 Connect one end of an optical cable to the TV Digital Audio (Optical) Output port.
- 2 Connect the other end of the optical cable to the digital audio (Optical) input on the audio equipment.
- 3 Set the "TV Speaker option - Off" in the AUDIO menu.(▶p.79). Refer to the external audio equipment instruction manual for operation.

CAUTION

- ▶ Do not look into the optical output port. Looking at the laser beam may damage your vision.

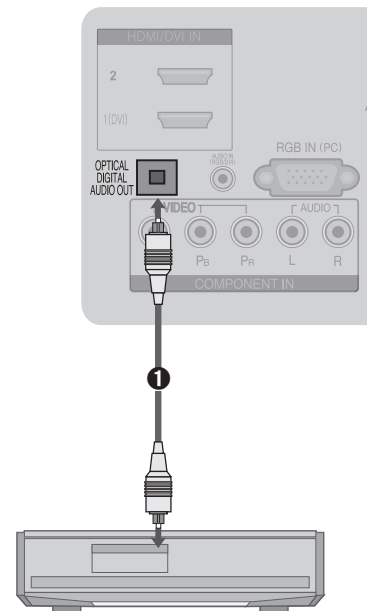

HEADPHONE SETUP

You can listen the sound through the headphone.

- 1 Plug the headphone into the headphone socket.
- 2 To adjust the headphone volume, press the \triangle + or - button. If you press the MUTE button, the sound from the headphone is switched off.

NOTE

- ▶ AUDIO menu items are disabled when connecting a headphone.
- ▶ When changing AV MODE with a headphone connected, the change is applied to video but not to audio.
- ▶ Optical Digital Audio Out is not available when connecting a headphone.

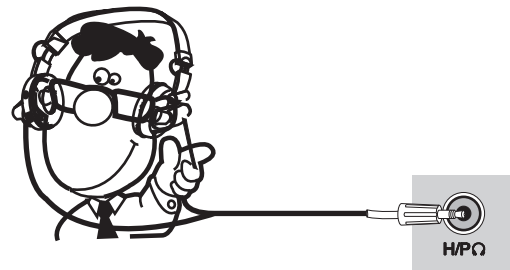

OTHER A/V SOURCE SETUP

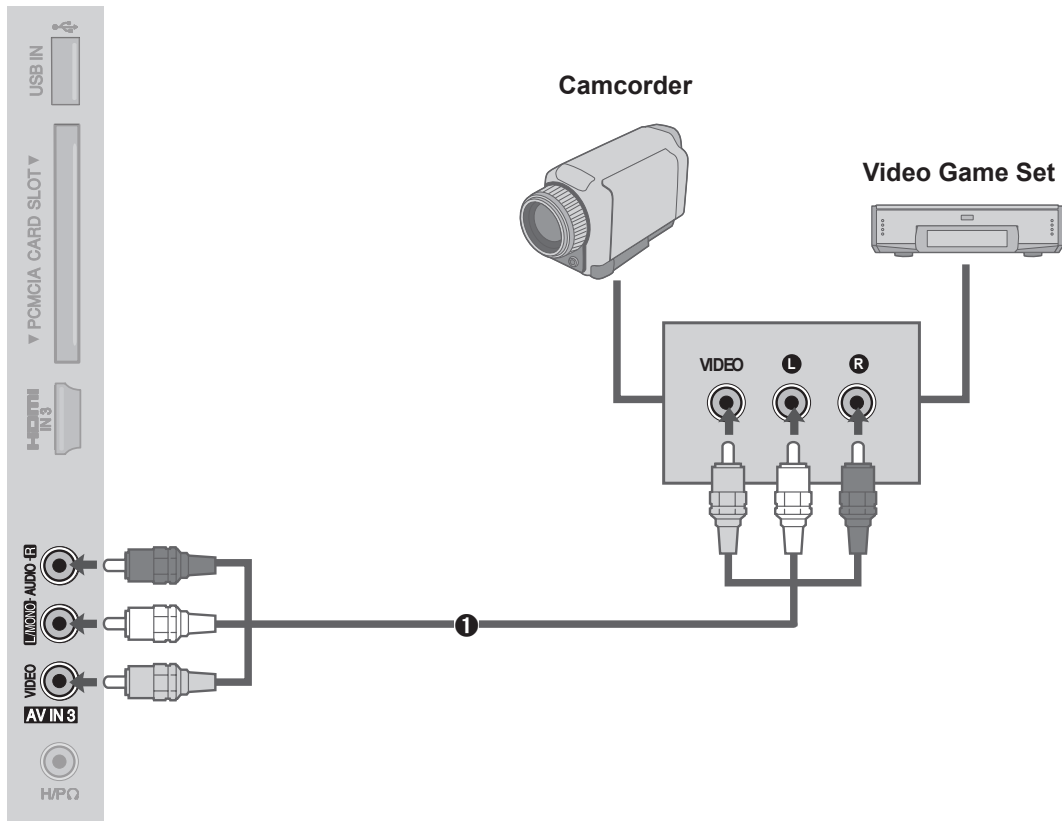

- 1 Connect the **AUDIO/VIDEO** jacks between TV and external equipment. Match the jack colours. (Video = yellow, Audio Left = white, and Audio Right = red)
- 2 Select **AV3** input source using the **INPUT** button on the remote control.
- 3 Operate the corresponding external equipment.
(Refer to external equipment operating guide.)

USB SETUP

- 1 Connect the USB device to the **USB IN** jack on the side of the TV.
- 2 After connecting the **USB IN** jack, you use the **USB** function. (►p.53)

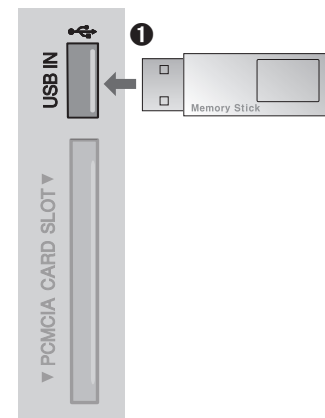

EXTERNAL EQUIPMENT SETUP

PC SETUP

This TV provides Plug and Play capability, meaning that the PC adjusts automatically to the TV's settings.

Connecting with a D-sub 15 pin Cable

- 1 Connect the RGB output of the PC to the **RGB IN (PC)** jack on the TV.
- 2 Connect the PC audio output to the **AUDIO IN (RGB/DVI)** jack on the TV.
- 3 Turn on the PC and the TV.
- 4 Select **RGB** input source using the **INPUT** button on the remote control.

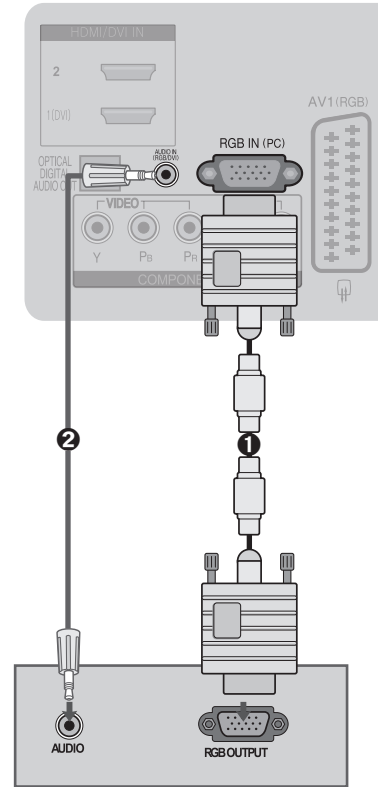

Connecting with an HDMI to DVI Cable

- 1 Connect the DVI output of the PC to the **HDMI/DVI IN 1** jack on the TV.
- 2 Connect the PC audio output to the **AUDIO IN (RGB/DVI)** jack on the TV.
- 3 Turn on the PC and the TV.
- 4 Select **HDMI 1** input source using the **INPUT** button on the remote control.

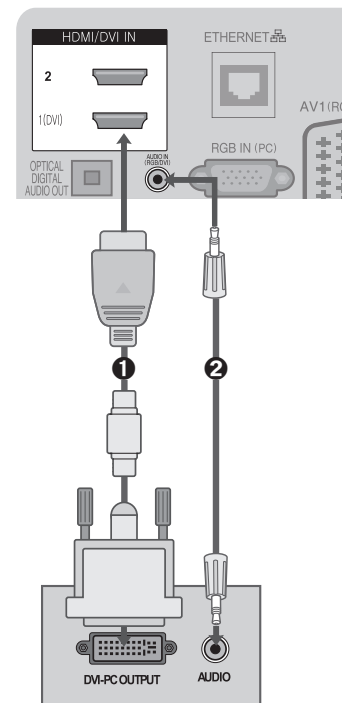

Supported Display Resolution

RGB(PC), HDMI1(DVI) -PC mode

Resolution	Horizontal Frequency(kHz)	Vertical Frequency(Hz)
720 x 400	31.468	70.08
640 x 480	31.469	59.94
800 x 600	37.879	60.31
1024 x 768	48.363	60.00
1280 x 768	47.78	59.87
1360 x 768	47.72	59.80
1280 x 1024	63.98	60.02
1400 x 1050	65.317	59.979
1920 x 1080	66.587	59.937

Component mode

Resolution	Horizontal Frequency(kHz)	Vertical Frequency(Hz)
720 x 480	15.73	59.94
	15.75	60
	31.47	59.9
	31.50	60
720 x 576	15.6	50
	31.25	50
1280 x 720	37.50	50.00
	44.96	59.94
	45.00	60.00
1920 x 1080	33.72	59.94
	33.75	60.00
	28.125	50.00
	56.25	50.00
	67.433	59.94
	67.500	60.00

HDMI2, HDMI3 -DTV mode

Resolution	Horizontal Frequency(kHz)	Vertical Frequency(Hz)
640 x 480	31.649	59.94
	31.469	60
720 x 480	31.47	59.94
	31.50	60
720 x 576	31.25	50.00
1280 x 720	37.50	50.00
	44.96	59.94
	45.00	60
1920 x 1080	28.125	50.00
	33.72	59.94
	33.75	60
	27.00	24.00
	33.750	30
	56.25	50.00
	67.433	59.94
	67.50	60

NOTE :

- ▶ Avoid keeping a fixed image on the TV's screen for prolonged periods of time. The fixed image may become permanently imprinted on the screen; use a screen saver when possible.
- ▶ There may be interference relating to resolution, vertical pattern, contrast or brightness in PC mode. Change the PC mode to another resolution or change the refresh rate to another rate or adjust the brightness and contrast on the menu until the picture is clear. If the refresh rate of the PC graphic card can not be changed, change the PC graphic card or consult the manufacturer of the PC graphic card.
- ▶ The synchronization input waveform for Horizontal and Vertical frequencies are separate.
- ▶ We recommend using 1920 x 1080, 60Hz for the PC mode, this should provide the best picture quality.
- ▶ Connect the signal cable from the monitor output port of the PC to the RGB IN(PC) port of the TV or the signal cable from the HDMI output port of the PC to the HDMI/DVI IN 1(DVI) port on the TV.
- ▶ Connect the audio cable from the PC to the AUDIO IN (RGB/DVI) on the TV. (Audio cables are not included with the TV).
- ▶ If using a sound card, adjust PC sound as required.
- ▶ If the graphic card on the PC does not output analogue and digital RGB simultaneously, connect only one of either RGB IN or HDMI/DVI IN 1(DVI) to display the PC output on the TV.
- ▶ If the graphic card on the PC does output analogue and digital RGB simultaneously, switch the TV to either RGB or HDMI; (the other mode is set to Plug and Play automatically by the TV.)
- ▶ DOS mode may not work depending on the video card if you use a HDMI to DVI cable.
- ▶ If you use too long an RGB-PC cable, there may be interference on the screen. We recommend using under 5m of cable. This provides the best picture quality.

EXTERNAL EQUIPMENT SETUP

Screen Setup for PC mode (In RGB mode only)

Selecting Resolution

To view a normal picture, match the resolution of RGB mode and resolution of PC.

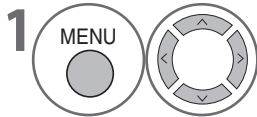
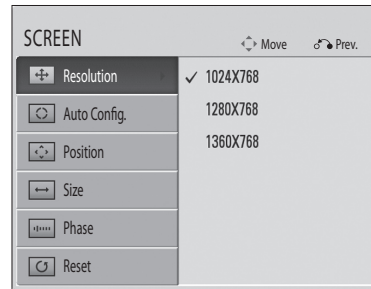
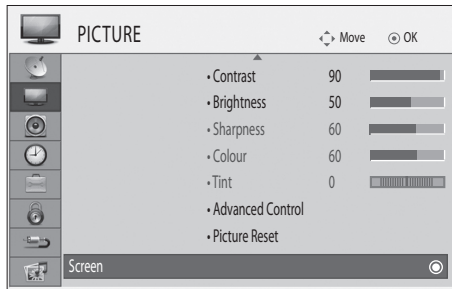

Select **PICTURE**.

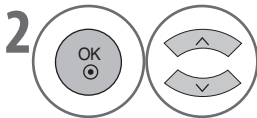

Select **Screen**.

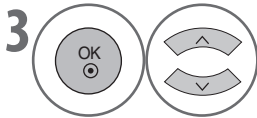

Select **Resolution**.

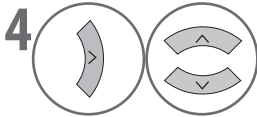

Select the desired resolution.

• The **Resolution** menu is disabled unless the resolution is set to 1024 x 768, 1280 x 768 or 1360 x 768.

- Press the **MENU** button to return to normal TV viewing.
- Press the **RETURN** button to return to the previous screen.

Auto Configure

Automatically optimizes the display. This is recommended for the first time connecting to a PC.

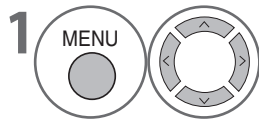
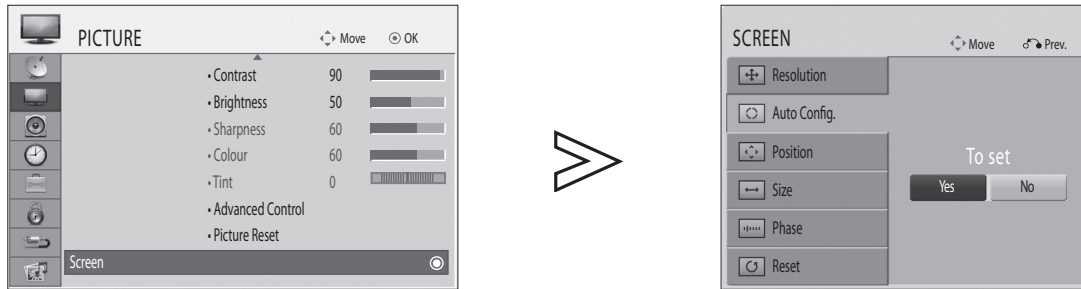

Select **PICTURE**.

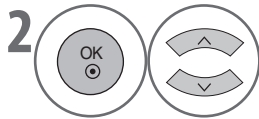

Select **Screen**.

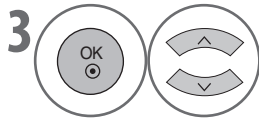

Select **Auto Config.**

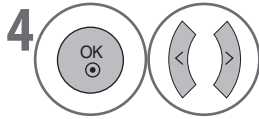

Select **Yes**.



Run **Auto Config.**

- If the picture is not clear after auto configuration, adjust the position, size or phase of picture manually.

- Press the **MENU** button to return to normal TV viewing.
- Press the **RETURN** button to return to the previous screen.

EXTERNAL EQUIPMENT SETUP

Adjustment for screen Position, Size, Phase

If the picture is not clear after auto adjustment and especially if characters are still trembling, adjust the picture phase manually.

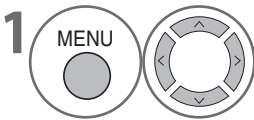
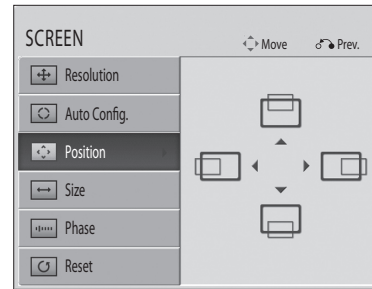
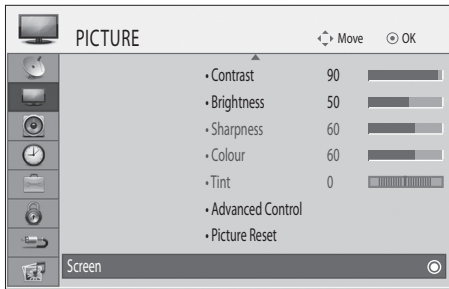

Select **PICTURE**.

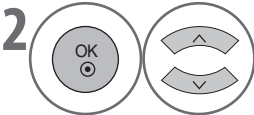

Select **Screen**.

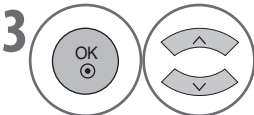

Select **Position, Size or Phase**.

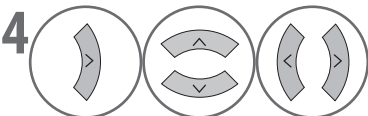



Make appropriate adjustments.

- Press the **MENU** button to return to normal TV viewing.
- Press the **RETURN** button to return to the previous screen.

Screen Reset

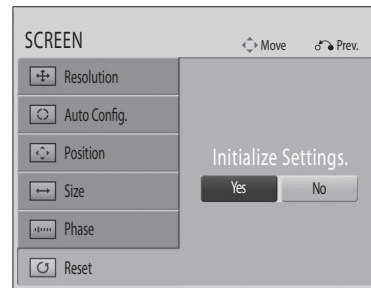
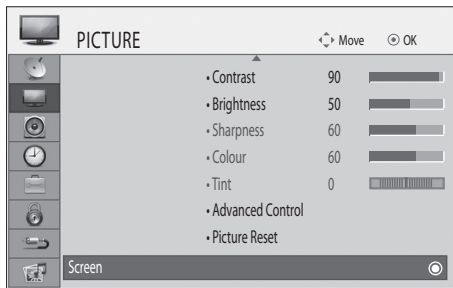
Returns Position, Size and Phase to the factory default settings.

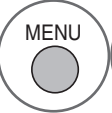
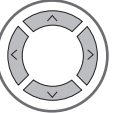
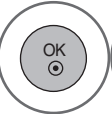
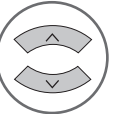
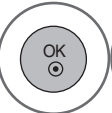
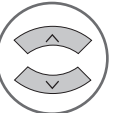

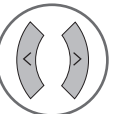
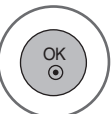
- 1   Select **PICTURE**.
- 2   Select **Screen**.
- 3   Select **Reset**.
- 4   Select **Yes**.
- 5  Run **Reset**.

- Press the **MENU** button to return to normal TV viewing.
- Press the **RETURN** button to return to the previous screen.

WATCHING TV / PROGRAMME CONTROL

REMOTE CONTROL KEY FUNCTIONS

When using the remote control, aim it at the remote control sensor on the TV.



ENERGY SAVING Adjust the Energy Saving mode of the TV. (▶ p.67)

RATIO It helps you select and set images and sounds when connecting AV devices.(▶ p.65)

POWER Switches the TV on from standby or off to standby.

INPUT Toggles between all AV inputs sequentially. (▶ p.49)

TV/RAD Selects Radio and TV channel.

Q. MENU Select the desired quick menu source. (Aspect Ratio, Energy Saving , Picture Mode, Sound Mode, Audio, Sleep Timer, Fav. On/Off, USB Eject).(▶p.33)

MENU Selects a menu.
Clears all on-screen displays and returns to TV viewing from any menu. (▶p.34)

GUIDE Shows programme schedule.(▶p.61)

Up/Down/Left/Right Allows you to navigate the on-screen menus and adjust the system settings to your preference.

OK Accepts your selection or displays the current mode.
Selects a menu.

RETURN (EXIT) Allows the user to move return one step in an interactive application, EPG or other user interaction function.

INFO Shows the present screen information.

AV MODE It helps you select and set images and sounds when connecting AV devices.(▶ p.50)

Coloured buttons These buttons are used for teletext. (on **TELETEXT** models only), Programme Edit or Multifeed.

TELETEXT BUTTONS These buttons are used for teletext. For further details, see the 'Teletext' section.(▶ p.93)

SUBTITLE Recalls your preferred subtitle in digital mode.



VOLUME UP/DOWN Adjusts the volume.

MARK Check and un-check programmes.

FAV Displays the selected favourite programme.

MUTE Switches the sound on or off.

Programme UP/DOWN Selects a programme.

PAGE UP/DOWN Move from one full set of screen information to the next one.

0~9 number buttons Selects a programme.
Selects numbered items in a menu.

LIST Displays the programme table. (▶p.48)

Q.VIEW Returns to the previously viewed programme.

USB Menu control buttons Controls USB menu (Photo List and Music List)

Installing Batteries

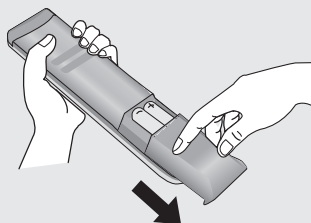

- Open the battery compartment cover on the rear and install the batteries paying attention to the correct polarity.
- Install two 1.5V AAA batteries. Do not mix old or used batteries with new ones.
- Close cover.

WATCHING TV / PROGRAMME CONTROL

TURNING ON THE TV

- When your TV is turned on, you will be able to use its features.

- 1 Firstly, connect the power cord pushing it firmly home and check the main power on the TV.
At this stage, the TV switches to standby mode. (The power indicator on the TV illuminates red.)
- 2 In standby mode to turn TV on, press the **POWER**, **INPUT** or **P \wedge V** (Programme Up/Down) button on the TV or press the **POWER**, **INPUT**, **P \wedge V** or **NUMBER** button on the remote control and the TV will switch on.

Initial Setting

This step will guide you to easily set the optimal viewing mode and tune the available channels. When you turn on the TV for the first time after purchase or if you perform **Factory Reset** in **OPTION**, initial setting will start automatically.

Language

Select your desired language.

Mode Setting

- Select the mode for your environment. Each mode provides the optimal picture settings for each environment.
- Select **Home Use** to use the TV in home. (default)
- Select **Store Demo** to use the TV in store. Even if the user changes the picture setting, the TV will automatically reset to initial settings after a certain period of time.
- The mode (Home Use, Store Demo) can be changed in the **OPTION > Mode Setting** menu.

Country

Select the country.

Time Zone

Select the time zone.

Tuning Mode

- Select the tuning mode to search the programmes you want.
- Select **Antenna** to find all terrestrial programmes.
- Select **Satellite** to find all satellite programmes.
- Select **Satellite & Antenna** to find both satellite and terrestrial programmes.
- **Satellite** and **Satellite & Antenna** lets you select **Default Programmes** or **Update**. Select **Default Programmes** if you want to apply the default channels of the satellite. Select **Update** to search more channels.

NOTE:

- ▶ If the initial setting menu disappears due to timeout without fully completing the channel searching procedure, you may not have all of the channels available. In this case, you can use the tuning menus in **SETUP** to search for more channels.
- ▶ Press the **RETURN** button to change the current OSD to the previous OSD.
- ▶ For those countries without confirmed DTV broadcasting standards, some DTV features might not work, depending on the DTV broadcasting environment.
- ▶ Language, Country and Time Zone are not available in UK.

PROGRAMME SELECTION

- 1 Press the **P \wedge V** (Programme Up/Down) or **NUMBER** buttons to select a programme number.

VOLUME ADJUSTMENT

- 1 Press the \triangleleft + or - button to adjust the volume.
If you wish to switch the sound off, press the **MUTE** button.
You can cancel this function by pressing the **MUTE**, \triangleleft + , - or **AV MODE** button.

CI+ CAM

1 Start-up Process

WHEN SWITCHING ON YOUR TV SET THE MESSAGE "SCRAMBLED PROGRAMME" APPEARS:

- ▶ The "Scrambled Programme" message may appear if your TV is switched on from standby to a Pay TV channel.
- ▶ The TV's start-up process may take longer due to the enhanced security for CI+ compared to a Free-to-Air channel.
- ▶ The TV's start-up time may vary depending on the kind of CI+ CAM (Common Interface Plus Conditional Access Module) and this is irrelevant to the functionality of the TV.

Start-up process with CI+ CAM is as follows.



LG Initial Logo



Channel Information

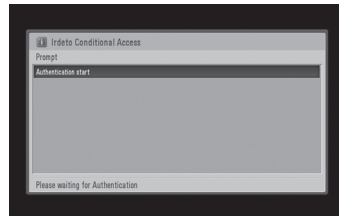

Authentication Start

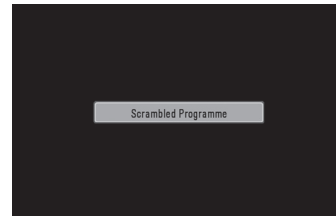

Scrambled Programme

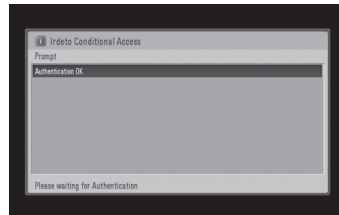

Authentication OK



Audio/Video Display

WATCHING TV / PROGRAMME CONTROL

2 CI+ CAM Authentication

WHEN CI+ CAM (CONDITIONAL ACCESS MODULE) IS INSERTED FOR THE FIRST TIME

Authentication Success

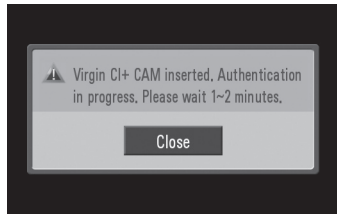

When the CI+ CAM is inserted for the first time

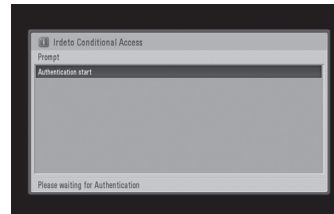

Authentication Start



Audio/Video Display

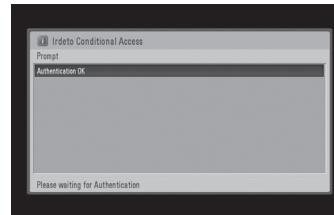









Authentication OK

Authentication Failed

1. When the authentication is failed, an error message appears.
2. Check whether
 - The antenna is connected correctly.
 - The channel search is complete.
 - The current channel is digital.
3. Remove the CI+ CAM and insert it again or turn the TV off and on.
The authentication will normally start.

QUICK MENU

Your TV's OSD (On Screen Display) may differ slightly from that shown in this manual. Q.Menu (Quick Menu) is a menu of features which users might use frequently.

	Aspect Ratio Selects your desired picture format. For Zoom Setting, select 14:9, Zoom and Cinema Zoom in the Ratio Menu. After completing Zoom Setting, the display goes back to Q.Menu.		Audio Selects the sound output.
	Energy Saving Selects your desired Energy Saving mode.		Sleep Timer Sets the sleep timer.
	Picture Mode Selects your desired Picture Mode.		Fav. On/Off Add the programme to the favourite list.
	Sound Mode It is a feature to automatically set the sound combination which it deems the best for the images being watched. Selects your desired Sound Mode.		USB Eject Select "Eject" in order to remove USB device.

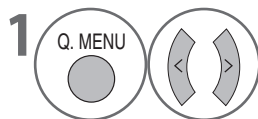

Display each menu.



Select your desired source.

- Press the **MENU** button to return to normal TV viewing.
- Press the **RETURN** button to return to the previous screen.

WATCHING TV / PROGRAMME CONTROL

ON SCREEN MENUS SELECTION AND ADJUSTMENT

Your TV's OSD (On Screen Display) may differ slightly from that shown in this manual.

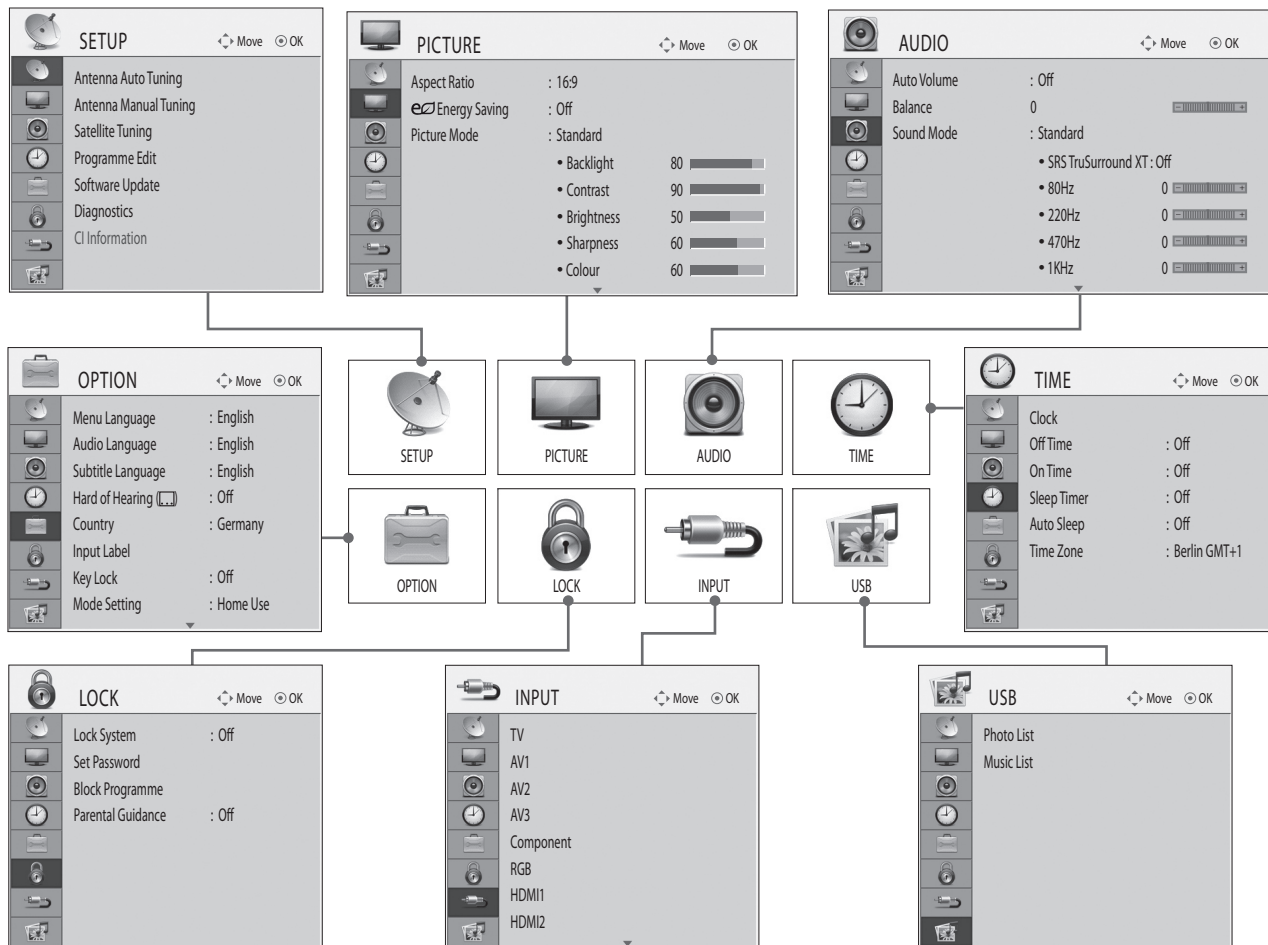

WATCHING TV / PROGRAMME CONTROL

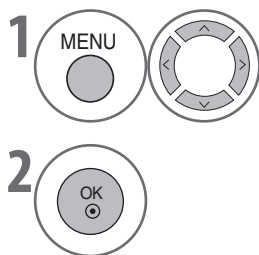

1 Press **MENU** to display the option icons, and navigate to the desired one using the Up/Down/Left/Right arrow keys.

2 Press **OK** to select a menu option and move to the pop up menu.

NOTE

► It is not possible to use **CI Information** in Analogue Antenna mode.

- Press the **MENU** button to return to normal TV viewing.
- Press the **RETURN** button to return to the previous screen.

ANTENNA AUTO PROGRAMME TUNING

Use this to automatically find and store all terrestrial programmes.

When you start auto programming, all previously stored service information will be deleted.

The maximum number of programmes that can be stored is 1098 (digital:999, analogue:99). But the number may differ slightly depending on broadcasting signals.

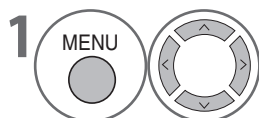
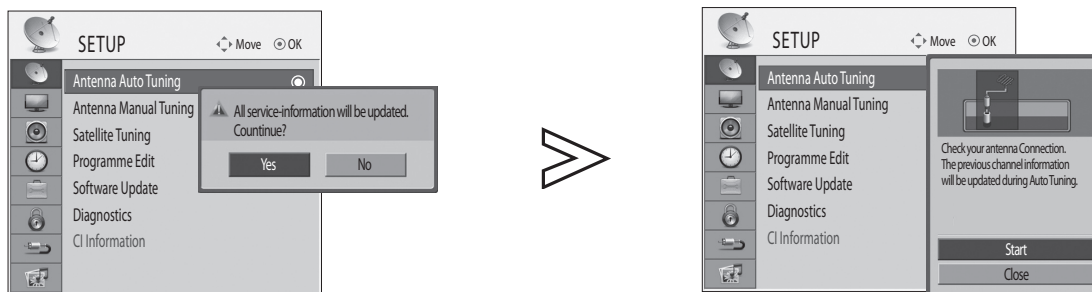

Select **SETUP**.

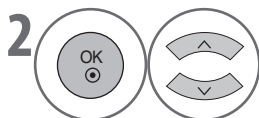

Select **Antenna Auto Tuning**.

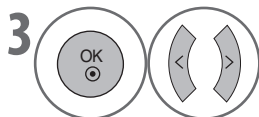

Select **Yes**.

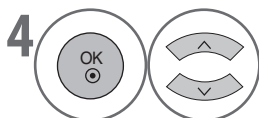

Select **Start**.



Run **Auto Tuning**.

The search results will appear.

The found programmes are automatically saved in order.

- If you have selected **On** in **LOCK > Lock System** menu, you will be prompted to enter your password to access. Use **NUMBER** buttons to input a 4-digit password.
- **Automatic Numbering:** You can set whether or not the channels are numbered automatically by broadcaster. (Supported only in country with LCN service)
- First tunes the digital TV and radio programmes, then analogue programmes.

- Press the **MENU** button to return to normal TV viewing.
- Press the **RETURN** button to return to the previous screen.

WATCHING TV / PROGRAMME CONTROL

ANTENNA MANUAL PROGRAMME TUNING (IN DIGITAL MODE)

Manual Tuning lets you manually add a programme to your programme list.

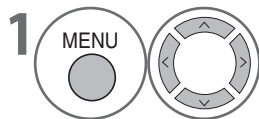
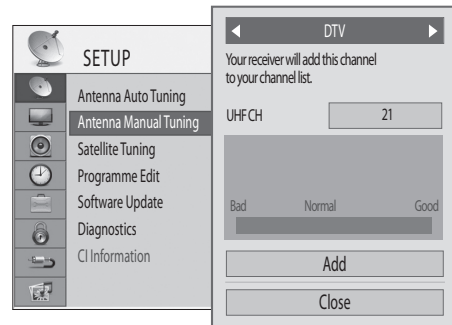

Select **SETUP**.

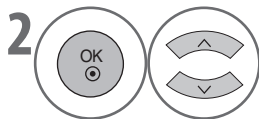

Select **Antenna Manual Tuning**.

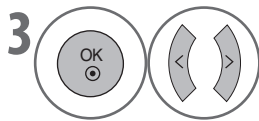

Select **DTV**.

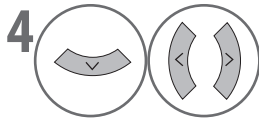

Select the desired channel number.

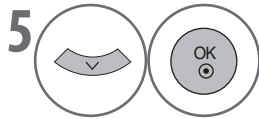

Select **Add**.

- If you have selected **On** in **LOCK > Lock System** menu, you will be prompted to enter your password to access. Use **NUMBER** buttons to input a 4-digit password.

- Press the **MENU** button to return to normal TV viewing.
- Press the **RETURN** button to return to the previous screen.

ANTENNA MANUAL PROGRAMME TUNING (IN ANALOGUE MODE)

Manual Tuning lets you manually tune and arrange the stations in whatever order you desire.

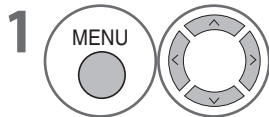
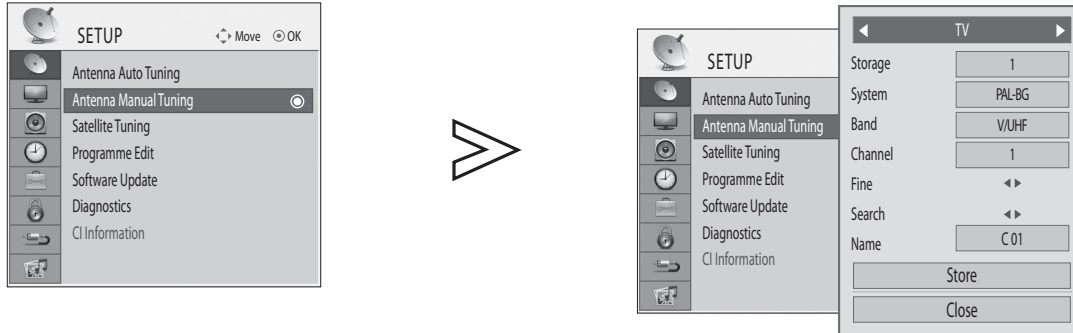

Select **SETUP**.

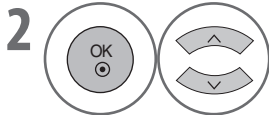

Select **Antenna Manual Tuning**.

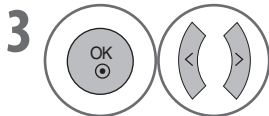

Select **TV**.

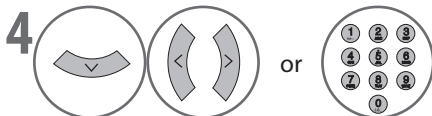

Select the desired programme number on.

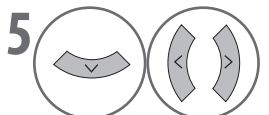

Select a TV system.

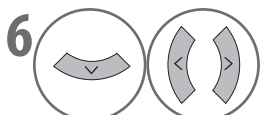

Select **V / UHF** or **Cable**.

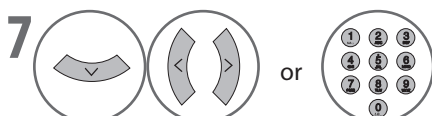

Select the desired channel number.

- If you have selected **On** in **LOCK > Lock System** menu, you will be prompted to enter your password to access. Use **NUMBER** buttons to input a 4-digit password.
- BG : PAL B/G, SECAM B/G (Europe / East Europe / Asia / New Zealand / M.East / Africa / Australia)
I : PAL I/II (U.K. / Ireland / Hong Kong / South Africa)
DK : PAL D/K, SECAM D/K (East Europe / China / Africa / CIS)
- To store another channel, report steps 4 to 9.

WATCHING TV / PROGRAMME CONTROL

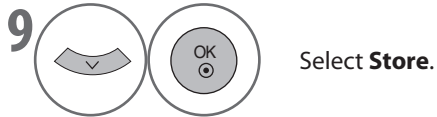

■ Assigning a station name

You can assign a station name with five characters to each programme number.

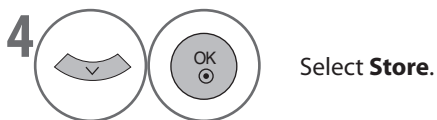
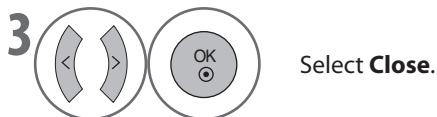
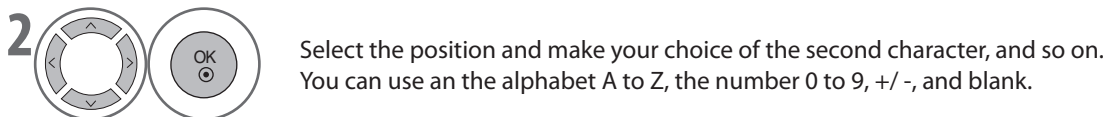
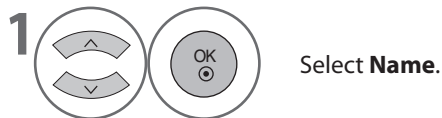

■ Fine Tuning

Normally fine tuning is only necessary if reception is poor.

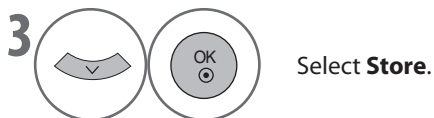
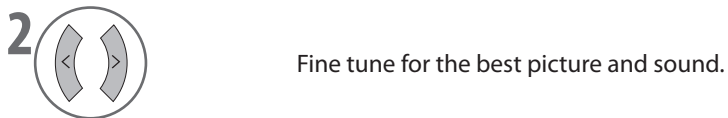

- Press the **MENU** button to return to normal TV viewing.
- Press the **RETURN** button to return to the previous screen.

SATELLITE TUNING (LNB ONLY)

Satellite Tuning lets you find and store all available satellite programmes.

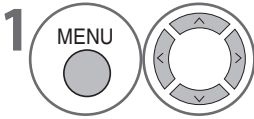
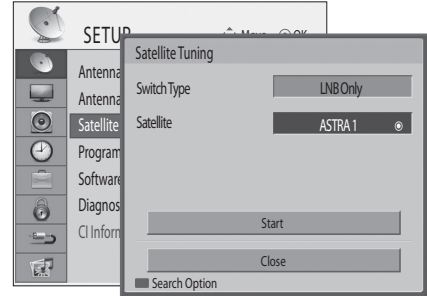
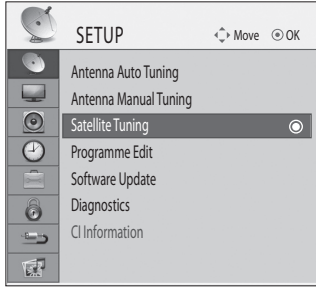

Select **SETUP**.

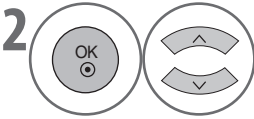

Select **Satellite Tuning**.

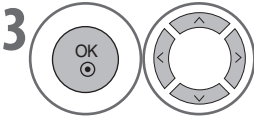

Select **Switch Type** and select **LNBOOnly**.
Every time you change the switch type, the previous antenna setting will be deleted.

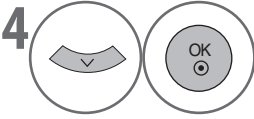

Select **Satellite**.

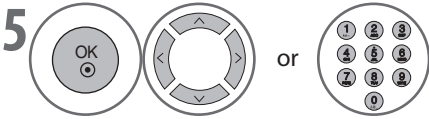

Select a satellite and set the **LNB Frequency**, **22Khz Tone** and **Transponder**.

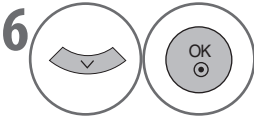

Select **Close**.

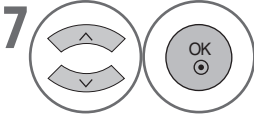

Select **Start**.

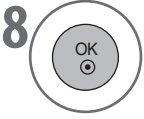

The search results will appear.
The found programmes are automatically saved in order.

- If you have selected **On** in **LOCK > Lock System** menu, you will be prompted to enter your password to access. Use **NUMBER** buttons to input a 4-digit password.
- Press the **RED** button in satellite tuning to enter search options such as network information, scramble type or programme type.
- Press the **RED** button in satellite setting to go to Transponder Setting.

- Press the **MENU** button to return to normal TV viewing.
- Press the **RETURN** button to return to the previous screen.

WATCHING TV / PROGRAMME CONTROL

SATELLITE TUNING (DiSEqC)

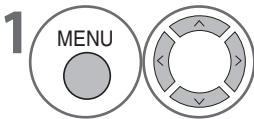
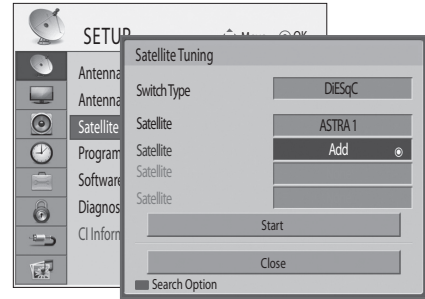
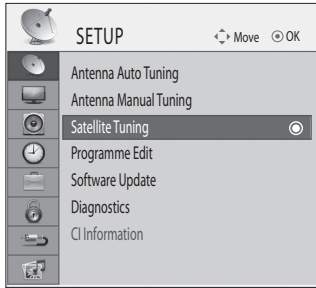

Select **SETUP**.

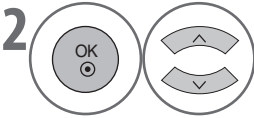

Select **Satellite Tuning**.

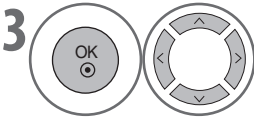

Select **Switch Type** and select **DiSEqC**.

Every time you change the switch type, the previous antenna setting will be deleted.

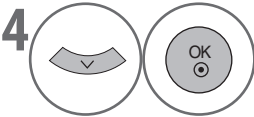

Select **Satellite**.

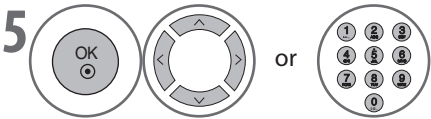

Select a satellite and set **DiSEqC**, **LNB Frequency**, **22Khz Tone** and **Transponder**. You can add up to four satellites.

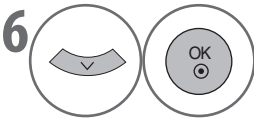

Select **Close**.

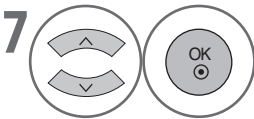

Select **Start**.

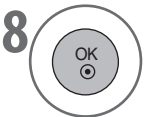

The search results will appear.
The found programmes are automatically saved in order.

- If you have selected **On** in **LOCK > Lock System** menu, you will be prompted to enter your password to access. Use **NUMBER** buttons to input a 4-digit password.
- Press the **RED** button in satellite tuning to enter search options such as network information, scramble type or programme type.
- Press the **RED** button in satellite setting to go to Transponder Setting.

- Press the **MENU** button to return to normal TV viewing.
- Press the **RETURN** button to return to the previous screen.

PROGRAMME EDIT

This function enables you to delete, move or select the programmes you want.

You can change the programme number using "Move" function, if "Automatic Numbering" is unchecked when you start Auto Tuning.

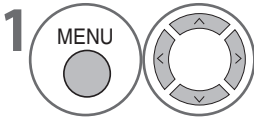
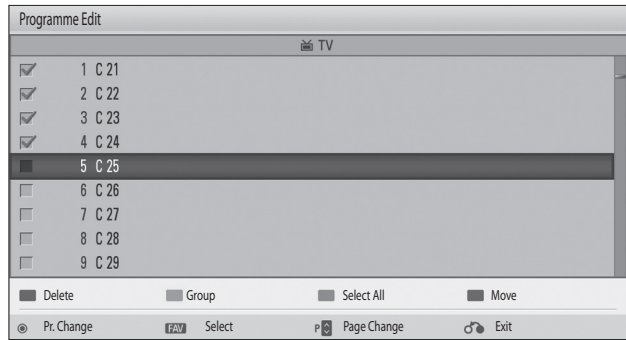
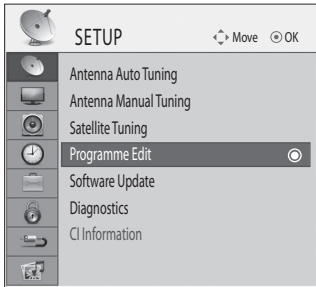

Select **SETUP**.

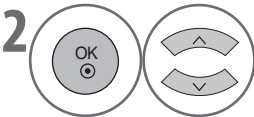

Select **Programme Edit**.



Enter the **Programme Edit**.

- If you have selected **On** in **LOCK > Lock System** menu, you will be prompted to enter your password to access. Use **NUMBER** buttons to input a 4-digit password.
- If the channel has the LCN, the **Move** function will not work.

■ Changing a programme



Select a programme you want to watch.



Switch to the selected programme.

■ Changing groups



Switch between TV and Radio groups.

- Press the **MENU** button to return to normal TV viewing.
- Press the **RETURN** button to return to the previous screen.

WATCHING TV / PROGRAMME CONTROL

■ Selecting programmes

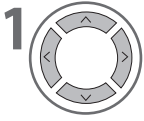

Select a programme.



Check the selected programme.



Check the all programmes.

■ Deleting programmes

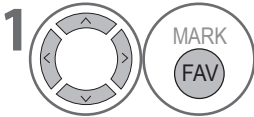

Select the programmes you want to delete.

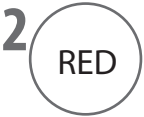

Delete the selected programmes.

■ Moving programmes

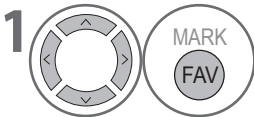

Select the programme you want to move.

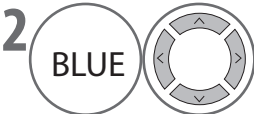

Shift the cursor to the position you want.



Move the selected programmes to the new location.

• After you finish the edit, press the **RETURN** or **EXIT** button to save all the changes.

- Press the **MENU** button to return to normal TV viewing.
- Press the **RETURN** button to return to the previous screen.

SOFTWARE UPDATE

Software Update allows you to update the system software to maintain proper performance of the product. The software can be downloaded through the digital broadcasting system.

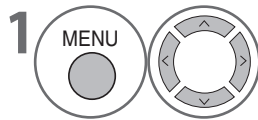
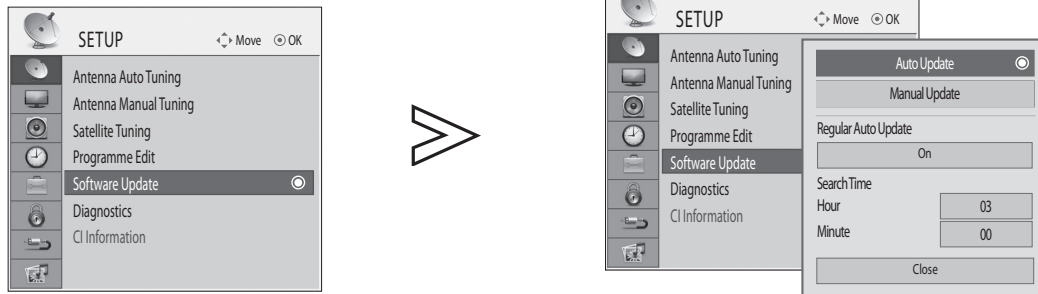

Select **SETUP**.

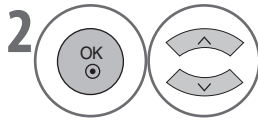

Select **Software Update**.

■ Auto Update

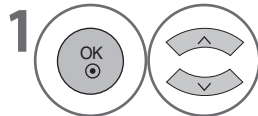

Select **Auto Update**.



Search for the new software. The new software information will be shown. Refer to "When detecting new software using Auto Update or Manual Update menu". (▶p.45)

- If you have selected **On** in **LOCK > Lock System** menu, you will be prompted to enter your password to access. Use **NUMBER** buttons to input a 4-digit password.

During Progress of a Software Update, please note the following:

- Power to the TV must not be interrupted.
- The TV must not be switched off.
- The antenna must not be disconnected.
- After Software Update, you can confirm the updated software version in Diagnostics menu.

- Press the **MENU** button to return to normal TV viewing.
- Press the **RETURN** button to return to the previous screen.

WATCHING TV / PROGRAMME CONTROL

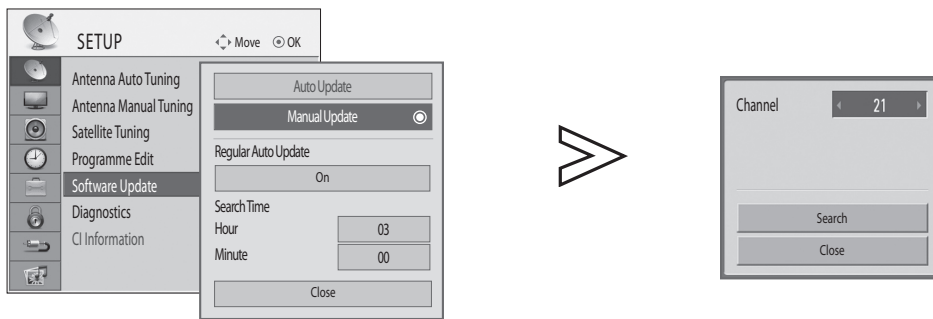

■ Manual Update

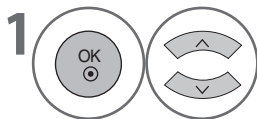

Select **Manual Update**.

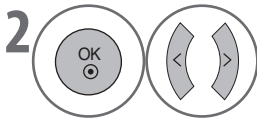

Select the desired channel number.

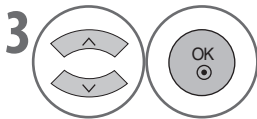

Select **Search**. Searches for the new software. The new software information will be shown. Refer to “When detecting new software using Auto Update or Manual Update menu”. (▶p.45)

■ Regular Auto Update

In standby mode, if the Regular Auto Update menu is “On”, the TV will search the new software automatically at the search time without switching to the operation mode.

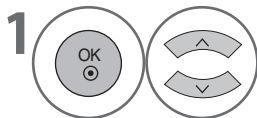

Select **Regular Auto Update**.

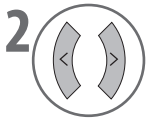

Select **On**.

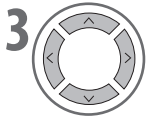

Select **Hour** or **Minute** and enter the search time.

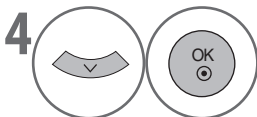

Select **Close**.

If the new software is detected, the software update message is displayed when you turn on the TV. Select **Yes** and press the **OK** button to start the software update.

- Press the **MENU** button to return to normal TV viewing.
- Press the **RETURN** button to return to the previous screen.

* WHEN DETECTING NEW SOFTWARE USING AUTO UPDATE OR MANUAL UPDATE MENU

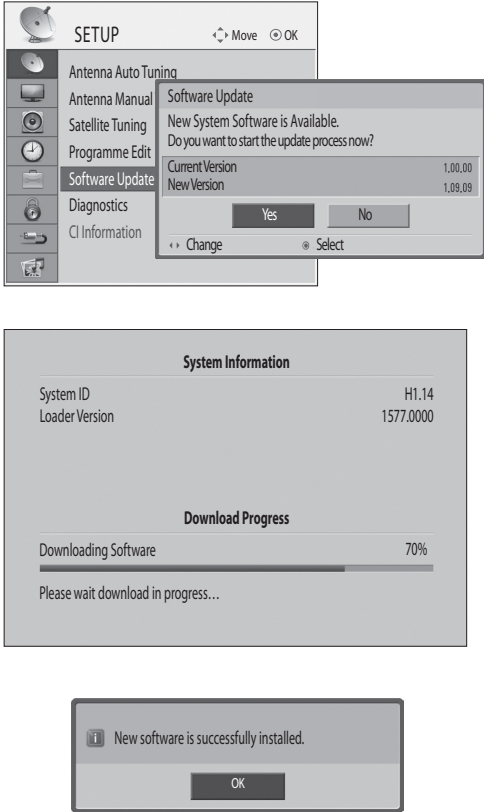

- 1 The new software information will be shown.
- 2 Select **Yes** using the <> button and press the **OK** button to start the software update.
 - Select **No** and press the **OK** button to return to the previous menu without updating.
- 3 The system restarts automatically and the update is started. The progress status is displayed. Please wait until it is complete.
- 4 After the software update is complete, the confirm message will be displayed and the system restarts automatically.

* WHEN DETECTING NEW SOFTWARE BY THE REGULAR AUTO UPDATE IN STANDBY MODE

- 1 When you turn on the TV after new software is detected, the software update message will be displayed.
- 2 Select **Yes** and press the **OK** button to start the software update. The progress status is displayed. Please wait until it is complete.
- 3 After the software update is complete, the confirm message will be displayed and the system restarts automatically.

WATCHING TV / PROGRAMME CONTROL

DIAGNOSTICS

This function enables you to view system status information such as Manufacturer, Model/Type, Update Date, Software Version, Loader Version, Micom Version, Strength, or Quality.

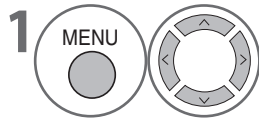
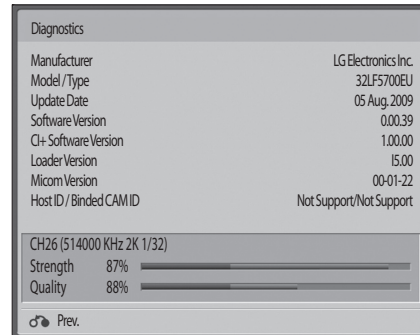
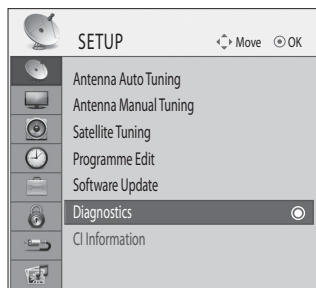

Select **SETUP**.

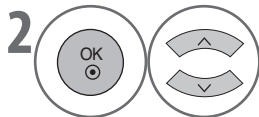

Select **Diagnostics**.



Display the **Diagnostics**.
The system status information will be displayed.

- Strength and quality disappear in Analogue mode.

- Press the **MENU** button to return to normal TV viewing.
- Press the **RETURN** button to return to the previous screen.

CI INFORMATION (IN DIGITAL MODE ONLY)

This function enables you to watch some encrypted digital terrestrial services (pay services). If you remove the CI Module, you cannot watch pay services.

When the module is inserted into the CI slot, you can access the module menu.

To purchase a module and smart card, contact your dealer. Do not repeatedly insert or remove a CI module from the TV. This may cause a malfunction. When the TV is turned on after inserting a CI Module, you may not have any sound output. This may be incompatible with the CI module and smart card.

CI (Common Interface) functions may not be possible depending upon the country broadcasting circumstances.

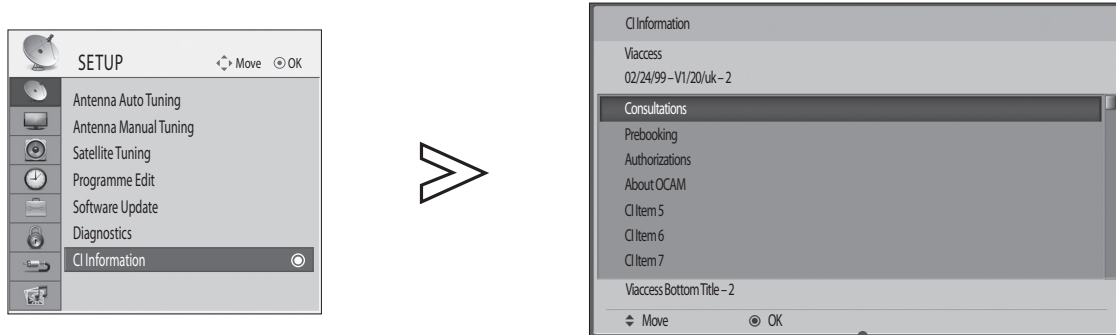

- This OSD is only for illustration and the menu options and screen format will vary according to the Digital pay services provider.
- It is possible for you to change CI (Common Interface) menu screen and service by consulting your dealer.

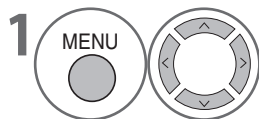

Select **SETUP**.

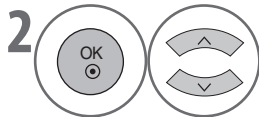

Select **CI Information**.

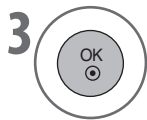

Display the **CI Information**.

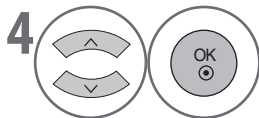





Select the desired item:
Module information, smart card information, language, or software download etc.

- Press the **MENU** button to return to normal TV viewing.
- Press the **RETURN** button to return to the previous screen.

WATCHING TV / PROGRAMME CONTROL

SELECTING THE PROGRAMME LIST

Various groups of programme lists are available for quick and easy navigation.

Colour Button	Group	Programmes
 RED	My TV	Display the list of all TV or Radio programmes.
 GREEN	Favourite	Display the list of all favourite programmes.
 YELLOW	HDTV	Display the list of all HDTV programmes.
 BLUE	Scrambled	Display the list of programmes classified by CAS types.

■ Displaying the List



Display or exit the programme list.

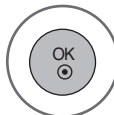

Switch to the selected programme.

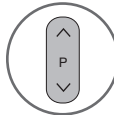

Change the page.



Switch between TV and Radio groups.

Four groups of programme lists are available; **My TV**, **Favourite**, **HDTV** and **Scrambled**. Press the colour buttons assigned to each group to display the programme list of each group.

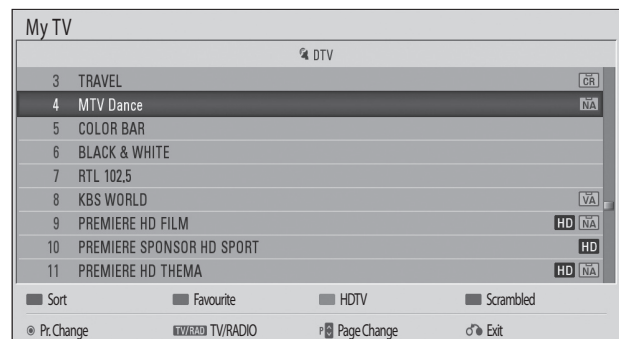

- You can directly display or exit the favourite programme list by pressing the **FAV** button.
- You can sort the programmes numerically or alphabetically in each group by pressing again the same colour button. (Except for Favourite group and Scrambled group)

INPUT LIST

HDMI and AV1, 2 (SCART) can be recognized by a detect pin and thus enabled only when an external device approves voltage.

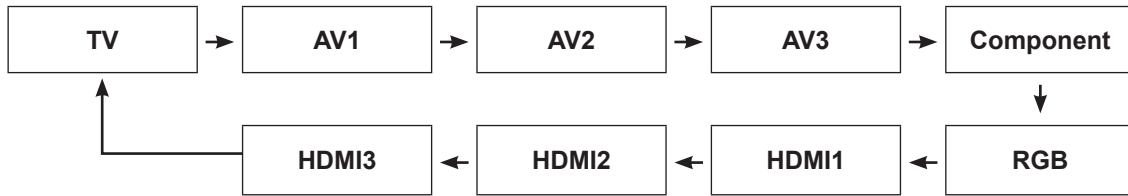

■ Using INPUT button

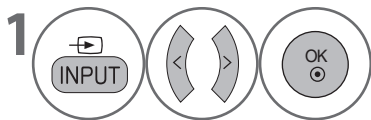

Select the input source.

• By pressing **INPUT** button repeatedly on the input list, you can move easily among the connected inputs.

■ Using MENU button

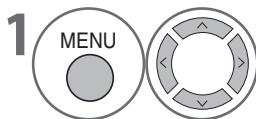

Select **INPUT**.

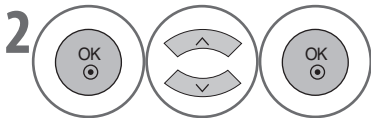

Select the input source.

- **TV** : Select it when watching the TV/Radio.
- **AV1, AV2, AV3** : Select it when watching the VCR or external equipment.
- **Component** : Select it when using the DVD or the Digital set-top box depends on connector.
- **RGB** : Select it when using PC depends on connector.
- **HDMI1, HDMI2, HDMI3** : Select it when using DVD, PC or Digital set-top box depend on connector.

WATCHING TV / PROGRAMME CONTROL

INPUT LABEL

Selects a label for each external input source.

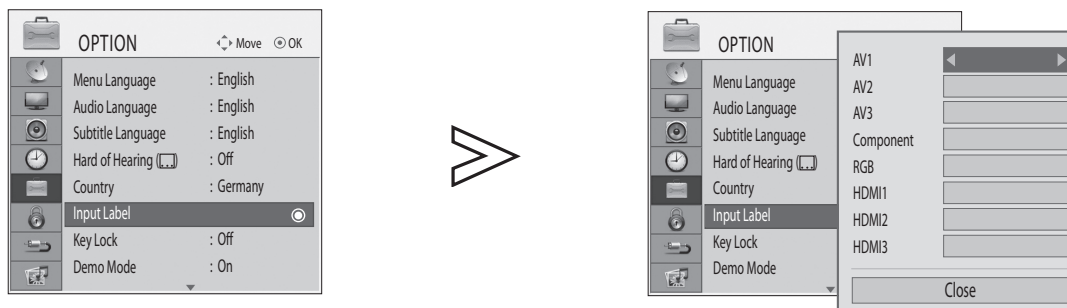

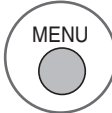
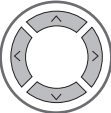
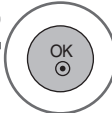
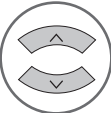
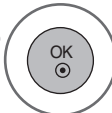
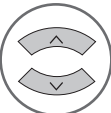
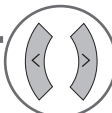
-   Select **OPTION**.
-   Select **Input Label**.
-   Select the source.
-  Select the label.

- Press the **MENU** button to return to normal TV viewing.
- Press the **RETURN** button to return to the previous screen.

AV MODE

By pressing **AV MODE** button repeatedly, you can select the optimal images and sounds when connecting AV devices to external input. (▶p.68)

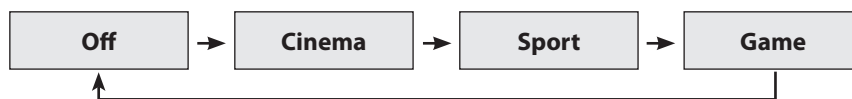

- If you select **Cinema** mode in AV mode, **Cinema** mode will be selected both for **Picture Mode** and **Sound Mode** in **PICTURE** menu and **AUDIO** menu respectively.
- If you select **"Off"** in AV mode, the picture and image which you initially set will be selected.

MULTIFEED

* This function is available only in Germany.

When turning to a multifeed channel, the multifeed icon will appear on the programme information banner.

You can choose from a choice of camera angles to watch the screen from different camera perspectives while watching a sports transmission. Different options are provided to view single matches or federal league games.

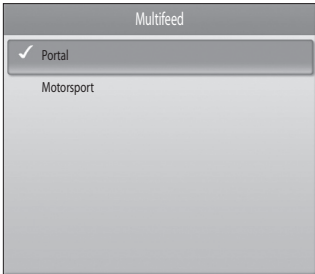

Display the Multifeed popup.

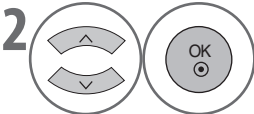

Select an option you want.

WATCHING TV / PROGRAMME CONTROL

INITIALIZING (RESET TO ORIGINAL FACTORY SETTINGS)



This function initializes all settings.

It is useful to initialize the product or when you move to other city or country.

When the Factory Reset is completed, you must restart the Initializing setup.

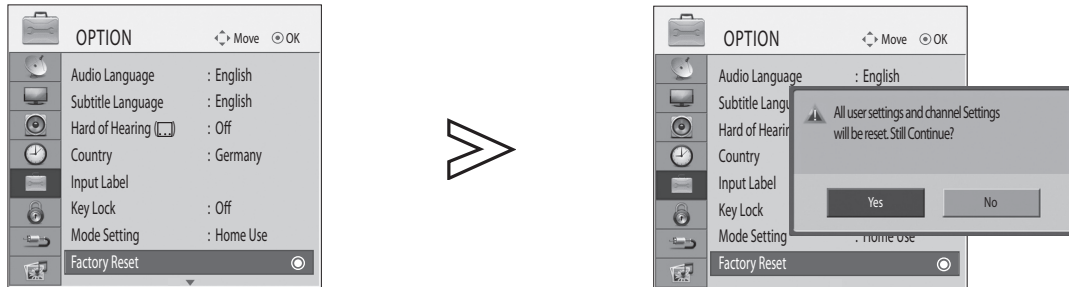
When the **Lock System** menu is "On", the message to enter the password appears.

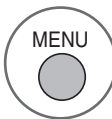
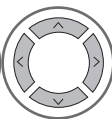
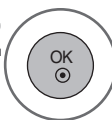
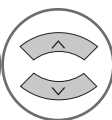

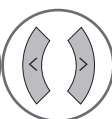
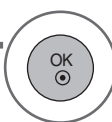
-   Select **OPTION**.
-   Select **Factory Reset**.
-   Select **Yes**.
-  Start **Factory Reset**.

- If you have selected **On** in **LOCK > Lock System** menu, you will be prompted to enter your password to access. Use **NUMBER** buttons to input a 4-digit password.
- If you have forgotten your password, press 7777 to reset your password.

- Press the **MENU** button to return to normal TV viewing.
- Press the **RETURN** button to return to the previous screen.

TO USE A USB DEVICE

When you connect a USB device, this pop up menu is displayed, automatically.

“POP UP MENU” will not be displayed while the OSD including Menu, EPG or Schedule list is activated.

When the Pop Up menu does not appear, you can select Music List or Photo List in the USB menu.

In USB device, you can not add a new folder or delete the existing folder.

- 1 Connect the USB device to the **USB IN** jacks on the side of TV.

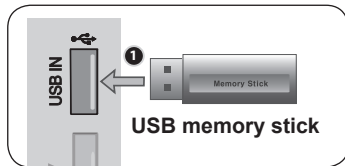

- It doesn't support USB HDD.
- This TV Supports on JPEG and MP3.

- 2 Select **PHOTO LIST** or **MUSIC LIST**.

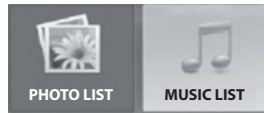
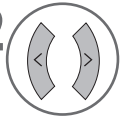

When removing the USB device

Select the USB EJECT menu before removing the USB device.

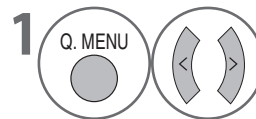

Select **USB Eject**.

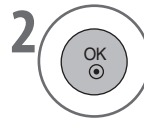

Precautions when using a USB device

- ▶ Only a USB storage device is recognizable.
- ▶ If the USB storage device is connected through a USB hub, the device is not recognizable.
- ▶ A USB storage device using an automatic recognition programme may not be recognized.
- ▶ A USB storage device which uses its own driver may not be recognized.
- ▶ The recognition speed of a USB storage device may depend on each device.
- ▶ Please do not turn off the TV or unplug the USB device when the connected USB storage device is working. When such device is suddenly separated or unplugged, the stored files or the USB storage device may be damaged.
- ▶ Please do not connect the USB storage device which was artificially maneuvered on the PC. The device may cause the product to malfunction or fail to be played. Never forget to use only a USB storage device which has normal music files or image files.
- ▶ Please use only a USB storage device which was formatted as a FAT32 file system provided with the Windows operating system. In case of a storage device formatted as a different utility programme which is not supported by Windows, it may not be recognized.
- ▶ Please connect power to a USB storage device (over 0.5A) which requires an external power supply. If not, the device may not be recognized.
- ▶ Please connect a USB storage device with the cable offered by the device maker. If you use a cable which is not offered by the device maker or an excessively long cable(max 5m), the device may not be recognized.
- ▶ Some USB storage devices may not be supported or operated smoothly.
- ▶ File alignment method of USB storage device is similar to Window XP and filename can recognize up to 100 English characters.
- ▶ Be sure to back up important files since data stored in a USB memory device may be damaged. We will not be responsible for any data loss.
- ▶ If your USB memory device has multiple partitions, or if you use a USB multi-card reader, you can use up to 4 partitions or USB memory devices.
- ▶ Only the FAT32 file system supports the delete function.
- ▶ If a USB memory device is connected to a USB multi-card reader, its volume data may not be detected.
- ▶ If the USB memory device does not work properly, disconnect and reconnect it.
- ▶ How fast a USB memory device is detected differs from device to device.
- ▶ The recommended capacity is 32GB or less for USB memory.
- ▶ Any device with more than the recommended capacity may not work properly.

TO USE A USB DEVICE

PHOTO LIST

You can view photo files on USB storage device.

The On Screen Display may be different from your TV. Images are an example to assist with the TV operation.

PHOTO(*.JPEG) supporting file

Baseline: 7680 x 4320

- You can play JPEG files only.
- Only baseline scan is supported among JPEG (SOF0, SOF1 only).
- Non-supported files are displayed in the form of bitmap.

Screen Components

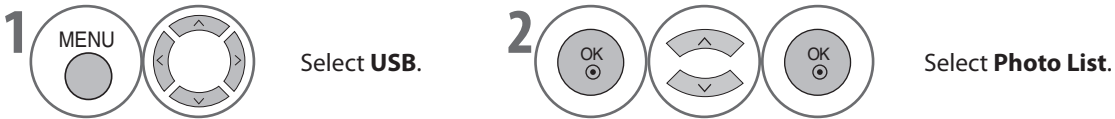

- 1 Moves to upper level file
- 2 Current page/Total pages
- 3 Total number of marked photos
- 4 Usable USB memory
- 5 Corresponding buttons on the remote control

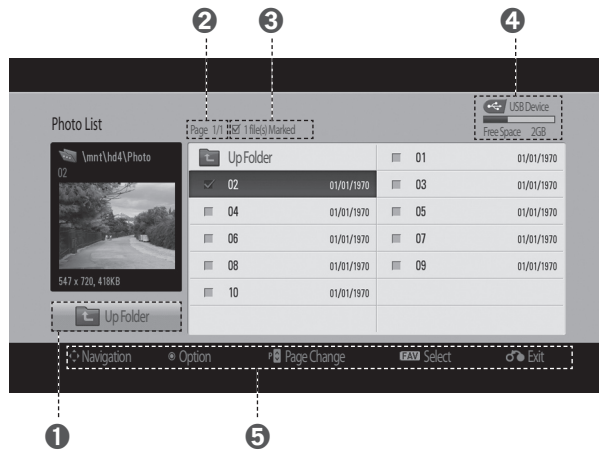
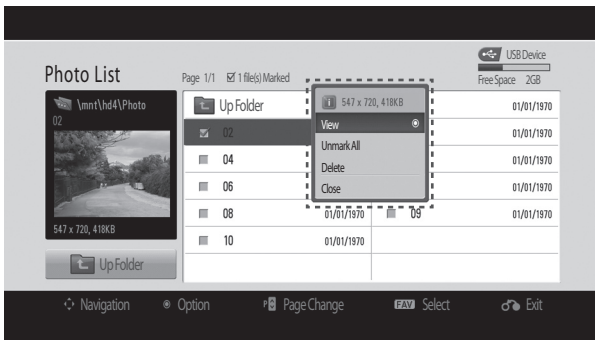
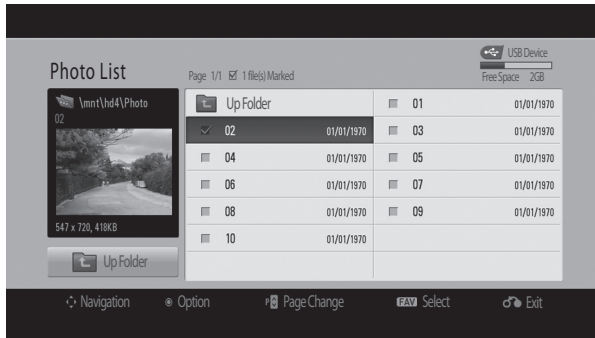
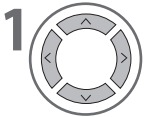

Photo Selection and PopUp Menu



- ▶ **View** : Display the selected item.
- ▶ **Mark All** : Mark all photos on the screen.
- ▶ **Unmark All** : Deselect all marked photos.
- ▶ **Delete** : Delete the selected photo item.
- ▶ **Close** : Close the pop-up menu.

TO USE THE USB DEVICE



Select the target folder or drive.

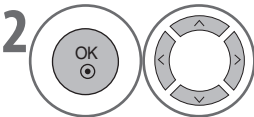

Select the desired photos.

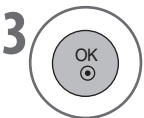

Show the PopUp menu.

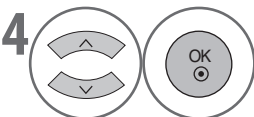

Select the desired PopUp menu.

- Use the **P** ^ v button to navigate in the photo page.
- Use the **MARK** button to mark or unmark a photo. When one or more photos are marked, you can view individual photos or a slide show of the marked photos. If no photos are marked, you can view all photos individually or all photos in the folder in a slide show.

• Press the **RETURN** button to return to the previous screen.

TO USE A USB DEVICE

How To View Photo

Detailed operations are available on full-sized photo view screen.

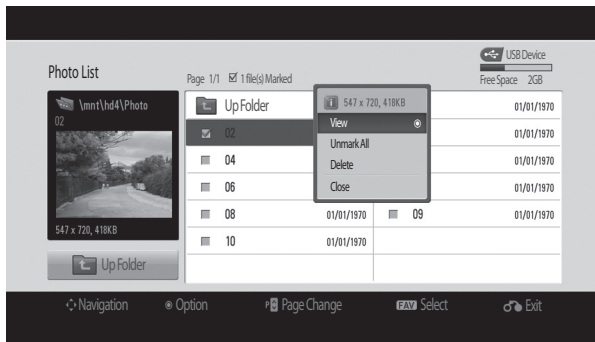
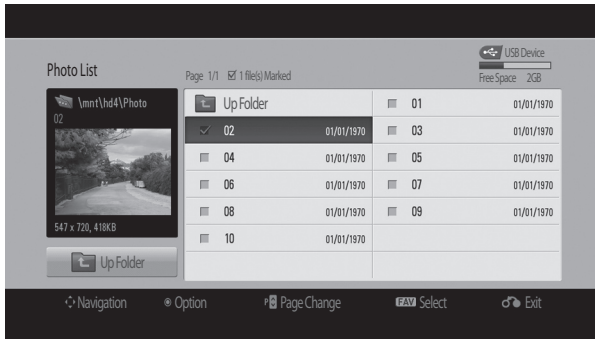

The aspect ratio of a photo may change the size of the photo displayed on the screen in full size.
Press the **RETURN** button to return to the previous screen.

TO USE THE USB DEVICE

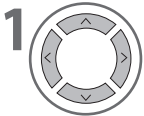

1 Select the target folder or drive.

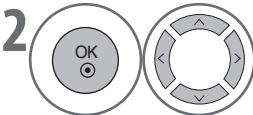

2 Select the desired photos.



3 Show the PopUp menu.

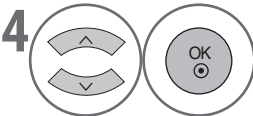

4 Select **View**.



5 The selected photo is displayed in full size.

- Use the **P** ^ v button to navigate in the photo page.

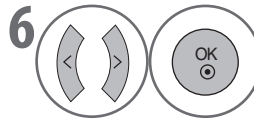

Select the **Slideshow**, **BGM**, **(Rotate)**, **Delete**, **Option** or **Close**.

- Use < > button to select the previous or next photo.
- Use √ < > and **OK** button to select and control the menu on the full-sized screen.

▶ **Slideshow:** When no picture is selected, all photos in the current folder are displayed during slide show. If some photos are selected, those photos are displayed in a slide show.

Set the time interval of the slide show in **Option**.

▶ **BGM(Background Music):** Listen to music while viewing photos in full size. Set the Music Folder for BGM in Options before using this function.

▶ **(Rotate) : Rotate photos.**

Rotates the photo 90°, 180°, 270°, 360° clockwise.

It can not be rotate when the width of a picture is bigger than supported height.

▶ **Delete :** Delete photos.

▶ **Option :** Set values for Slide Speed and Music Folder for BGM.

Use √ < > button and **OK** button to set values. Then go to **OK** and press **OK** to save the settings.

You cannot change **Music Folder** while BGM is playing.

▶ **Close :** Hide the menu on the full-sized screen.

To see the menu again on the full-sized screen, press **OK** button to display.

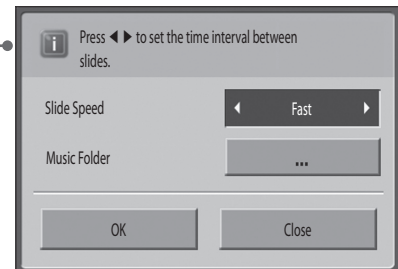

TO USE A USB DEVICE

MUSIC LIST

You can play music files on USB storage device.

Purchased music files (*.MP3) may contain copyright restrictions. Playback of these files may not be supported by this model.

Music file on your USB device can be played by this unit.

The On Screen Display may be different from your TV. Images are an example to assist with the TV operation.

MUSIC (*.MP3) supporting file

Bit rate 32 ~ 320

- Sampling rate MPEG1 layer 3: 32 kHz, 44.1 kHz, 48 kHz.

Screen Components

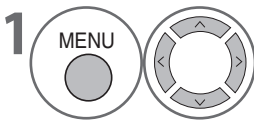

Select **USB**.

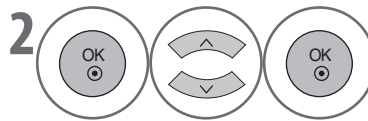

Select **Music List**.

- 1 Moves to upper level file
- 2 Current page/Total pages
- 3 Total number of marked musics
- 4 Usable USB memory
- 5 Corresponding buttons on the remote control

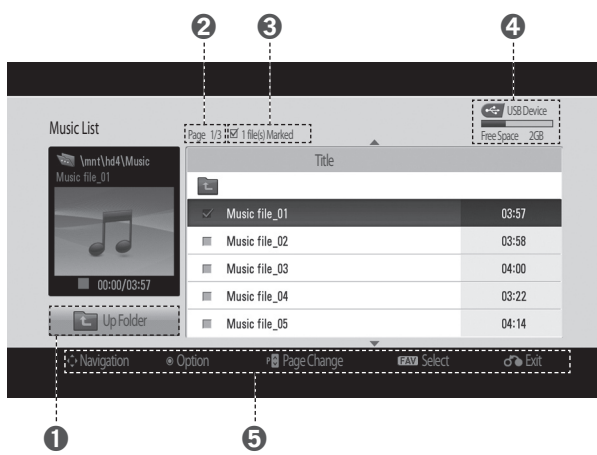

Music Selection and PopUp Menu

As shown , up to 6 music titles are listed per page.

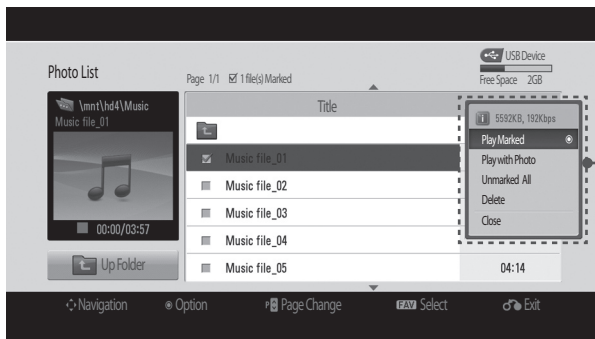
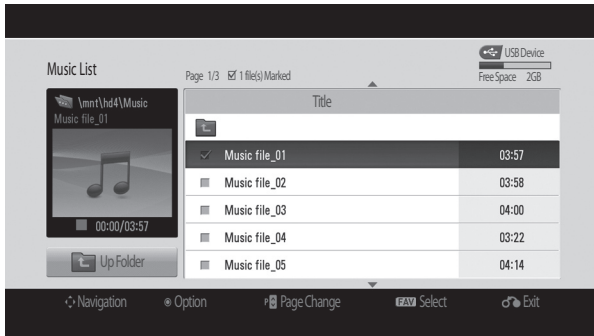

- ▶ **Play (During stop)** : Play the selected musics.
Once a music finishes playing, the next selected one will be played. When there are no selected musics to play, the next one in the current folder will be played. If you go to a different folder and press the **OK** button, the current music in playback will stop.
- ▶ **Stop Play (During playback)** : Stop the playing musics.
- ▶ **Play with Photo** : Start playing the selected musics and then move to the Photo List.
- ▶ **Mark All** : Mark all musics in the folder.
- ▶ **Unmark All** : Deselect all marked musics.
- ▶ **Delete** : Delete the selected musics.
- ▶ **Close** : Close the pop-up menu.

TO USE THE USB DEVICE

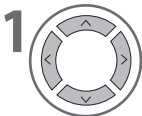

1 Select the target folder or drive.

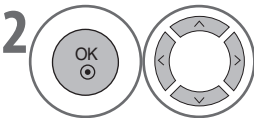

2 Select the desired musics.



3 Show the PopUp menu.

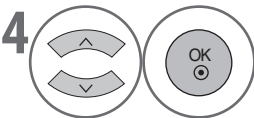

4 Select the desired PopUp menu.

- Use the **P** button to navigate in the music page.
- Use the **MARK** button to mark or unmark a music.
When one or more music files are marked, the marked musics will be played in sequence. For example, if you want to listen to only one music repeatedly, just mark the music only and play it. If no music is marked, all the music in the folder will be played in sequence.

- Press the **RETURN** button to return to the previous screen.

TO USE A USB DEVICE

- If you don't press any button for a while during the playing, the play information box (as shown in the below) will float as a screen saver.
- Screen saver is to prevent screen pixel damage due to an fixed image remaining on the screen for a extended period of time.

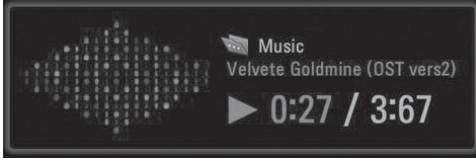

NOTE

- ▶ When music is playing,  is displayed in back of the music title.
- ▶ A damaged or corrupted music does not play but displays 00:00 in playtime.
- ▶ A music downloaded from a paid service with copyright protection does not start but displays inappropriate information in playtime.
- ▶ If you press ■ button screen saver is stopped.
- ▶ The **PLAY** (▶), **Pause** (||), ■, ▶▶, ◀◀ buttons on the remote control are also available in this mode.
- ▶ You can use the ▶▶ button to select the next music and the ◀◀ button to select the previous music.

TV GUIDE (EPG; ELECTRONIC PROGRAMME GUIDE) (IN DIGITAL MODE)

The **TV GUIDE** displays the programmes for the next 7 days sent by the broadcaster.
Three modes are available for quick search and reminder; **Table**, **Schedule** and **Find**.



Display or exit the TV Guide.



Move to **Schedule** mode.



Move to **Find** mode.



Move to **Table** mode.

TV GUIDE (EPG; ELECTRONIC PROGRAMME GUIDE) (IN DIGITAL MODE)

Button Function in Table Mode

You can view the programme information of all channels in time and date order.

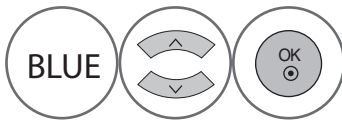
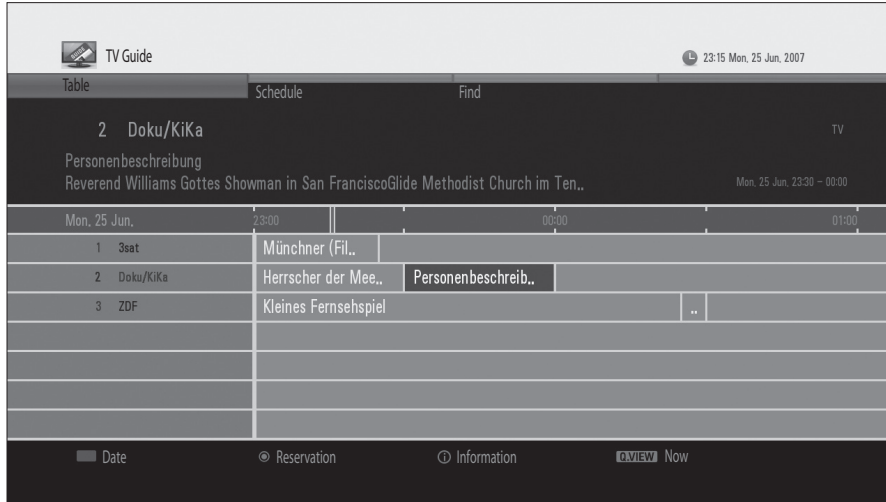

Change the date.

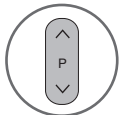

Change the page.



Switch between TV and Radio groups.

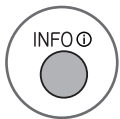

Display the programme information.

■ Selecting a programme



Select a programme on air.

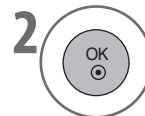

Switch to the selected programme.

■ Reserving the watching



Select a programme in the future.



Reserve the watching of the selected programme. (To cancel, press it again.) The reserved programmes are added automatically in **Schedule**.

Button Function in Schedule Mode

Schedule displays the list of the programmes reserved. You can edit, delete or add the reminders.

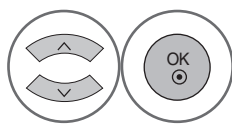

Edit or add a reminder.



Delete a reminder.

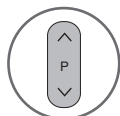

Change the page.

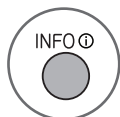

Display the programme information.

■ Editing/Adding the reminder

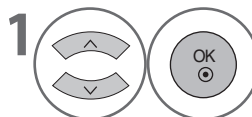

Select a reservation and display the Reminder popup.

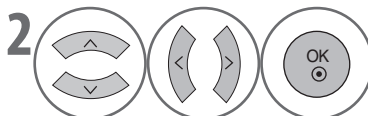

Select each option and enter the values.

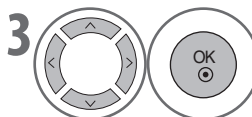

Select **OK** to save.

TV GUIDE (EPG; ELECTRONIC PROGRAMME GUIDE) (IN DIGITAL MODE)

Button Function in Find Mode

Find enables you to find the programme you want by entering the keyword, genre, time and day of the programme.

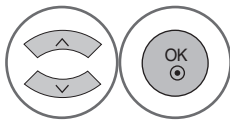

Input the Keyword, Genre, Time, Day values and select **Search**.



Display the previous inputted values.

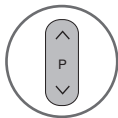

Change the page.

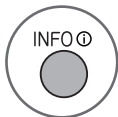

Display the programme information.

■ Selecting a programme

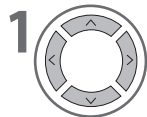

Select a programme on air.



Switch to the selected programme.

■ Reserving the watching



Select a programme in the future.



Reserve the watching of the selected programme. (To cancel, press it again.) The reserved programmes are added automatically in **Schedule**.

PICTURE CONTROL

PICTURE SIZE (ASPECT RATIO) CONTROL

You can watch the screen in various picture formats; 16:9, Just Scan, Original, Full Wide, 4:3, 14:9, Zoom and Cinema Zoom 1.

If a fixed image is displayed on the screen for a long time, that fixed image may become imprinted on the screen and remain visible.

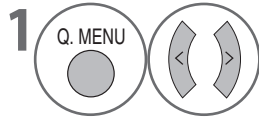

Select **Aspect Ratio**.



Select the desired picture format.

- You can also adjust **Aspect Ratio** in the **PICTURE** menu.
- By pressing **OK** button in **14:9, Zoom** or **Cinema Zoom 1**, you can adjust the zoom size and position. After completing Zoom Setting, the display goes back to Q.Menu.

- **16:9**

The following selection will allow you to adjust the picture horizontally, in linear proportion, to fill the entire screen (useful for viewing 4:3 formatted DVDs).



- **Just Scan**

Following Selection will lead you view the picture of best quality without loss of original picture in high resolution image.

NOTE :

- ▶ If there is noise in original Picture, you can see the noise at the edge.

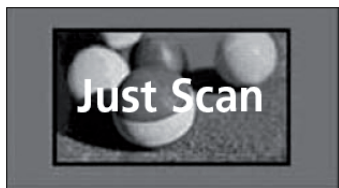

- **Original**

When your TV receives a wide screen signal it will automatically change to the picture format broadcast.



- **Full Wide**

When TV receives the wide screen signal, it will lead you to adjust the picture horizontally or vertically, in a linear proportion, to fill the entire screen fully.

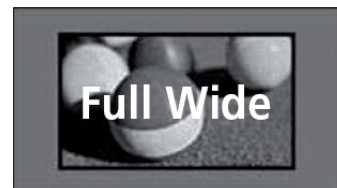

PICTURE CONTROL

- **4:3**

The following selection will allow you to view a picture with an original 4:3 aspect ratio, gray bars will appear on both the left and right of the screen.



- **14:9**

You can view a picture format of 14:9 or a general TV programme in the 14:9 mode. The 14:9 screen is viewed in the same way as in 4:3, but is magnified to the left and right.



- **Zoom**

The following selection will allow you to view the picture without any alteration, while filling the entire screen. However, the top and bottom of the picture will be cropped.

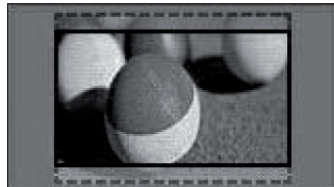

- **Cinema Zoom 1**

Choose Cinema Zoom 1 when you want to enlarge the picture in correct proportion.

NOTE :

- ▶ When enlarging or reducing the picture, the image may become distorted.



◀ or ▶ button : Adjust enlarge proportion of Cinema Zoom. The adjustment range is 1~16.

▲ or ▼ button : Move the screen.

NOTE :

- ▶ You can only select 4:3, 16:9 (Wide), 14:9, Zoom, Cinema Zoom 1 in Component, HDMI mode.
- ▶ You can only select 4:3, 16:9 (Wide) in RGB mode only.
- ▶ In HDMI/Component/Digital TV (over 720p) mode, Just Scan is available.

e ENERGY SAVING

It reduces the TV's power consumption.

You can increase the brightness of your screen by adjusting the **Energy Saving level** or by setting the **Picture Mode**.

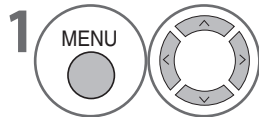
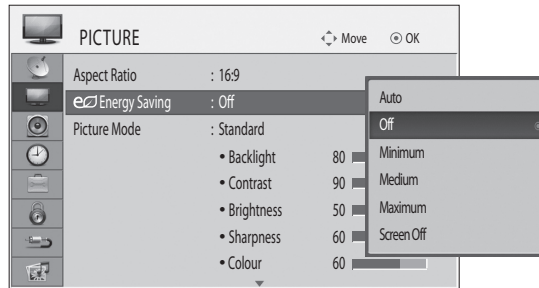

Select **PICTURE**.

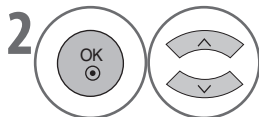

Select **e Energy Saving**.

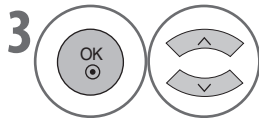

Select **Auto, Off, Minimum, Medium, Maximum** or **Screen Off**.

- When selecting Screen off, TV turned off after 3 seconds.
- If you adjust “**Energy Saving-Minimum, Medium, Maximum**”, Backlight feature will not work.
- You can also adjust this feature by selecting **Energy Saving** button on the remote control.
- When selecting Auto, Backlight is automatically adjusted through intelligent sensor according to the surrounding condition when intelligent sensor is in the TV.

- Press the **MENU** button to return to normal TV viewing.
- Press the **RETURN** button to return to the previous screen.

PICTURE CONTROL

PRESET PICTURE SETTINGS - PICTURE MODE

Intelligent Sensor	Adjusts picture according to the surrounding conditions.
Vivid	Strengthen the contrast, brightness, colour and sharpness for vivid picture.
Standard	The most general screen display status.
Natural	The most natural screen display status.
Cinema	Optimizes video for watching movies.
Sport	Optimizes video for watching sports events.
Game	Optimizes video for playing games.

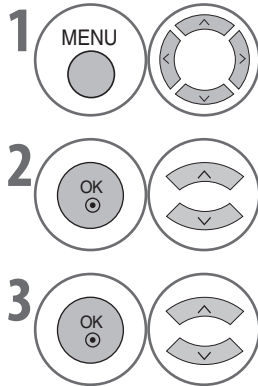
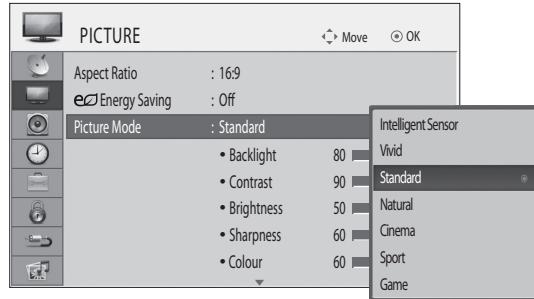

1 Select **PICTURE**.

2 Select **Picture Mode**.

3 Select **Intelligent Sensor, Vivid, Standard, Natural, Cinema, Sport** or **Game**.

- **Picture Mode** adjusts the TV for the best picture appearance. Select the preset value in the **Picture Mode** menu based on the programme category.
- You can also adjust **Picture Mode** in the **Q. Menu**.
- **Intelligent Sensor** : Adjusts picture according to the surrounding conditions.

- Press the **MENU** button to return to normal TV viewing.
- Press the **RETURN** button to return to the previous screen.

MANUAL PICTURE ADJUSTMENT - USER MODE

■ Backlight

To control the brightness of the screen, adjust the brightness of LCD panel.

Adjusting the backlight when setting the brightness of the set is recommended.

■ Contrast

Adjusts the signal level between black and white in the picture. You may use Contrast when the bright part of the picture is saturated.

■ Brightness

Adjusts the base level of the signal in the picture.

■ Sharpness

Adjusts the level of crispness in the edges between the light and dark areas of the picture. The lower the level, the softer the image.

■ Colour

Adjusts intensity of all colours.

■ Tint

Adjusts the balance between red and green levels.

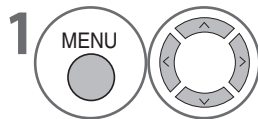
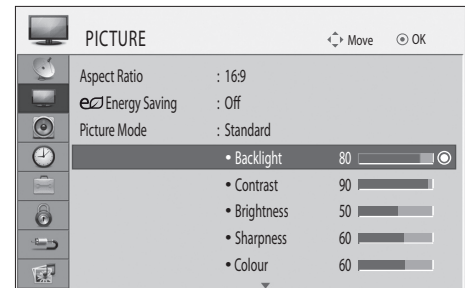

Select **PICTURE**.

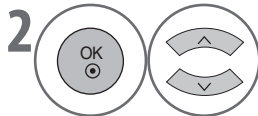

Select **Picture Mode**.

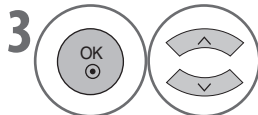

Select **Vivid, Standard, Natural, Cinema, Sport** or **Game**.

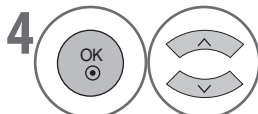

Select **Backlight, Contrast, Brightness, Sharpness, Colour** or **Tint**.

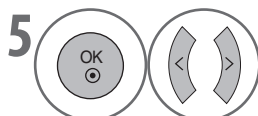

Make appropriate adjustments.

• Benefits of using Backlight

- The electricity consumption is reduced by up to 60%.
- The black brightness is reduced. (As the black has greater depth, you can enjoy a better quality definition.)
- You can adjust brightness with maintaining original signal resolution.

NOTE

- ▶ You cannot adjust colour, sharpness and tint in the RGB-PC mode.

- Press the **MENU** button to return to normal TV viewing.
- Press the **RETURN** button to return to the previous screen.

PICTURE CONTROL

PICTURE IMPROVEMENT TECHNOLOGY

You can calibrate the screen for each Picture Mode or set the video value according to the special video screen.

You can set the video value differently for each input.

To reset to the factory default screen after making adjustments to each video mode, execute the "Picture Reset" function for each Picture Mode.

(Only 32LF57**)

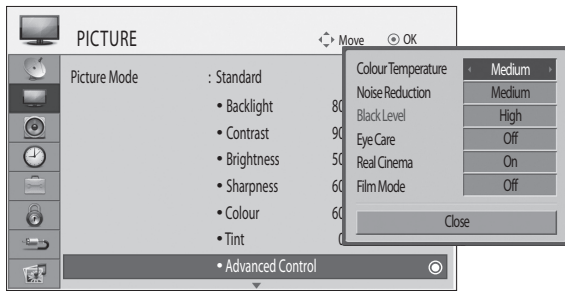

(Only 32LH57**/42LF57**/42LH57**)

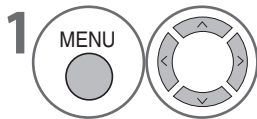
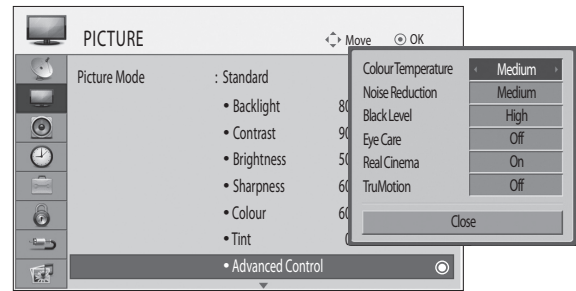

Select **PICTURE**.

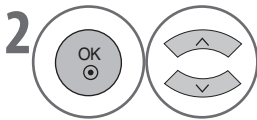

Select **Advanced Control**.

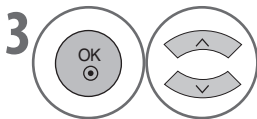

Select your desired source.
Colour Temperature, Noise Reduction, Black Level, Eye Care, Real Cinema, Film Mode
 or **TruMotion**. (▶p.71)



Make appropriate adjustments.

- Press the **MENU** button to return to normal TV viewing.
- Press the **RETURN** button to return to the previous screen.

Colour Temperature (Warm/Medium/Cool)	<ul style="list-style-type: none"> ■ Choose one of three automatic colour adjustments. Set to warm to enhance hotter colours such as red, or set to cool to make picture bluish.
Noise Reduction (Off/Low/Medium/High)	<ul style="list-style-type: none"> ■ Reduces screen noise without compromising video quality
Black Level (Low/High)	<ul style="list-style-type: none"> • Low : The picture of the screen gets darker. • High : The picture of the screen gets brighter. ■ Set black level of the screen to proper level. ■ This function enables to select 'Low' or 'High' in the following mode: AV(NTSC-M), HDMI or Component.
Eye Care (On/Off)	<ul style="list-style-type: none"> ■ Adjust the brightness of the screen to prevent the screen from being too bright. Dims extremely bright pictures. ■ This feature is disable in "Picture Mode-Vivid, Cinema, Intelligent Sensor".
Real Cinema (On/Off)	<ul style="list-style-type: none"> ■ Makes video clips recorded in film look more natural by eliminating judder effect. ■ This function can work when TruMotion is off.
Film Mode (On/Off)	<p>*(Only 32LF57**)</p> <ul style="list-style-type: none"> ■ Makes video clips recorded in film look more natural by eliminating judder effect.
TruMotion (Off/Low/High)	<p>*(Only 32LH57**/42LF57**/42LH57**)</p> <ul style="list-style-type: none"> • High : Provides smoother picture movement. • Low : Provides smooth picture movement. Use this setting for standard use. • Off : Use this setting when "High" and "Low" setting result in noise. ■ TruMotion can reduce perception of blur on fast moving scenes by displaying one hundred images per second. ■ It is used for the best picture quality without any motion blur or judder when you enter a quick image or Film Source. ■ This feature is disable in RGB-PC, HDMI-PC mode. ■ If you enable "TruMotion", noise may appear on the screen. If this occurs, set "TruMotion" to "Off".

PICTURE CONTROL

PICTURE RESET

Settings of the selected picture modes return to the default factory settings.

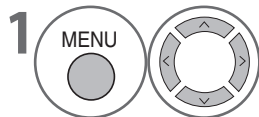
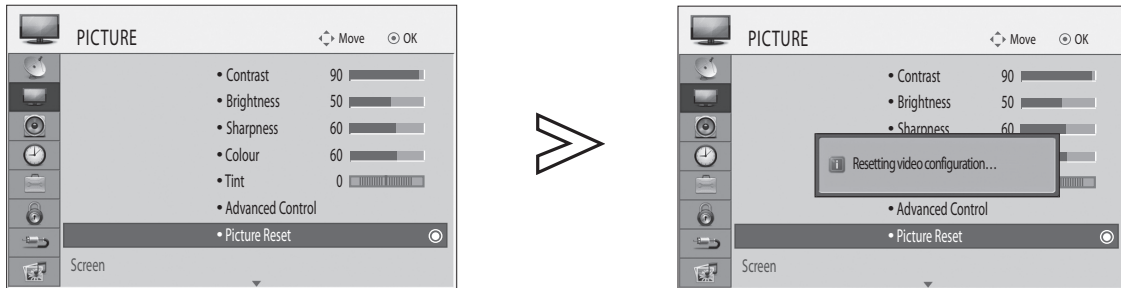

Select **PICTURE**.

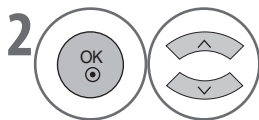

Select **Picture Reset**.



Initialize the adjusted value.

- Press the **MENU** button to return to normal TV viewing.
- Press the **RETURN** button to return to the previous screen.

DEMO MODE (Only 32LH57**/42LF57**/42LH57**)

Display the slide show to explain the various logo of this TV.

It is not possible to use **Demo Mode** in **Home Use** mode.

In **Store Demo**, **Demo Mode** is automatically set to **On**.

Once **Demo Mode** is set to **Off** in **Store Demo**, **Demo Mode** does not run and only the screen is reset.

The screen is reset automatically after 5 minutes in **Demo Mode**.

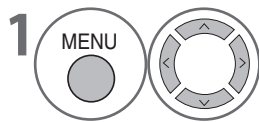
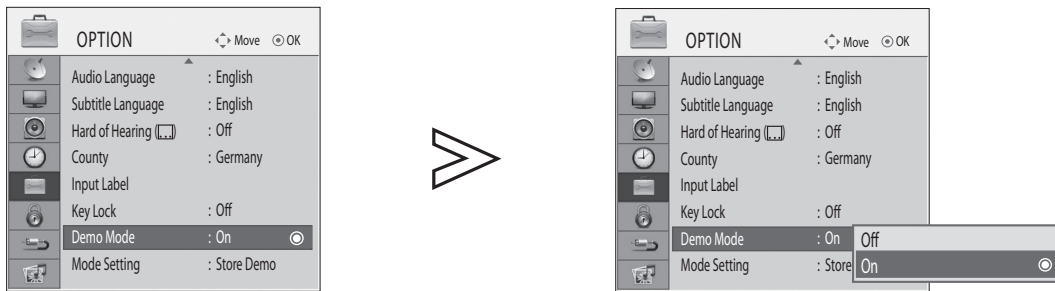

Select **OPTION**.

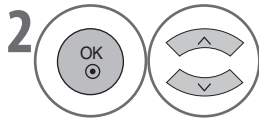

Select **Demo Mode**.

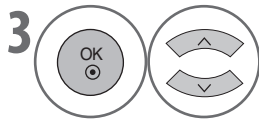

Select **On** to show the various logo of TV.



Return to TV viewing.

If you want to stop the demo, press any button. (except for **MUTE**, \triangle + , - button).

- Press the **MENU** button to return to normal TV viewing.
- Press the **RETURN** button to return to the previous screen.



PICTURE CONTROL

MODE SETTING

We recommend setting the TV to “**Home Use**” mode for the best picture in your home environment.

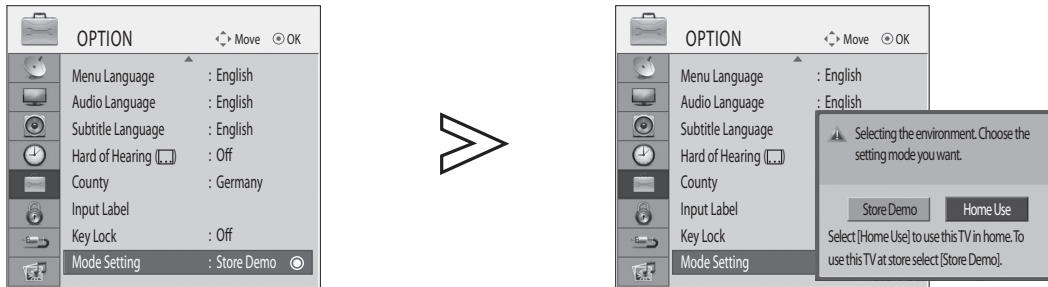
“**Store Demo**” mode is an optimal setting for displaying at stores.

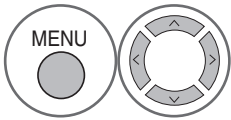
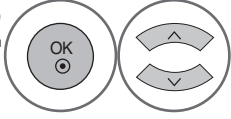
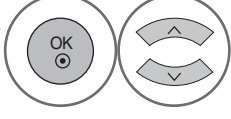

-  Select **OPTION**.
-  Select **Mode Setting**.
-  Select **Store Demo** or **Home Use**.
-  Save.

- Press the **MENU** button to return to normal TV viewing.
- Press the **RETURN** button to return to the previous screen.

SOUND & LANGUAGE CONTROL

AUTO VOLUME LEVELER

AVL automatically remains on the same level of volume if you change programmes.

Because each broadcasting station has its own signal conditions, volume adjustment may be needed every time the channel is changed. This feature allows users to enjoy stable volume levels by making automatic adjustments for each program.

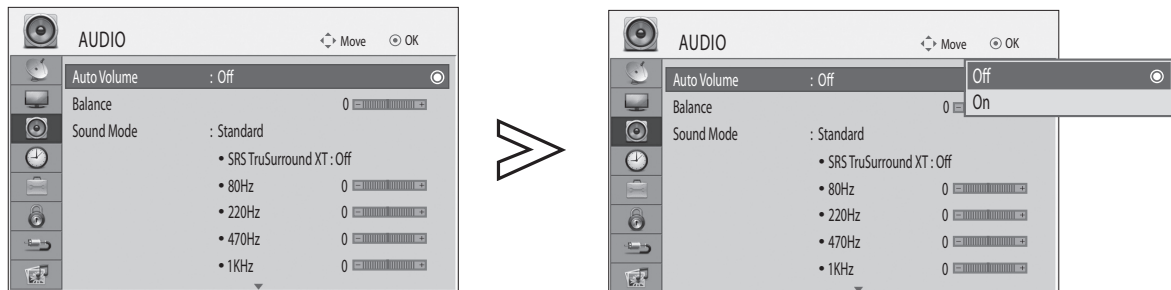

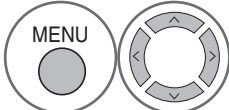
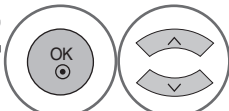
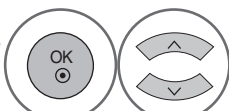
-  Select **AUDIO**.
-  Select **Auto Volume**.
-  Select **On** or **Off**.

- Press the **MENU** button to return to normal TV viewing.
- Press the **RETURN** button to return to the previous screen.

SOUND & LANGUAGE CONTROL

PRESET SOUND SETTINGS - SOUND MODE

You can select your preferred sound setting; Standard, Music, Cinema, Sport or Game and you can also adjust the frequency of the equalizer.

Sound Mode lets you enjoy the best sound without any Special adjustment as the TV sets the appropriate sound options based on the programme content.

Standard, Music, Cinema, Sport and Game are preset for optimum sound quality at the factory.

Standard	Offers standard-quality sound.
Music	Optimizes sound for listening to music.
Cinema	Optimizes sound for watching movies.
Sport	Optimizes sound for watching sports events.
Game	Optimizes sound for playing games.

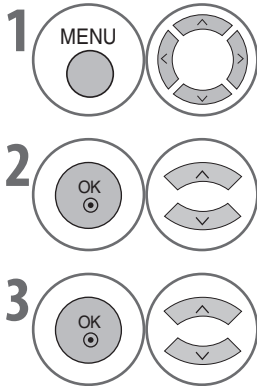
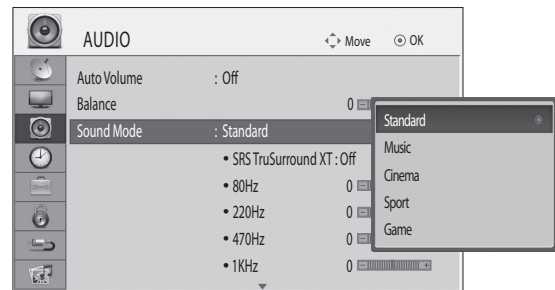
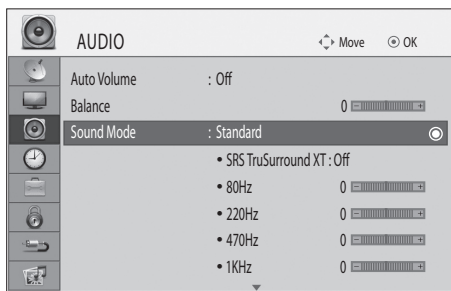

Select **AUDIO**.

Select **Sound Mode**.

Select **Standard, Music, Cinema, Sport or Game**.

• You can also adjust **Sound Mode** in the **Q. Menu**.

- Press the **MENU** button to return to normal TV viewing.
- Press the **RETURN** button to return to the previous screen.

MANUAL SOUND SETTING ADJUSTMENT - USER MODE

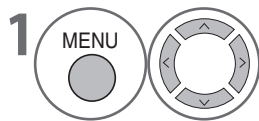
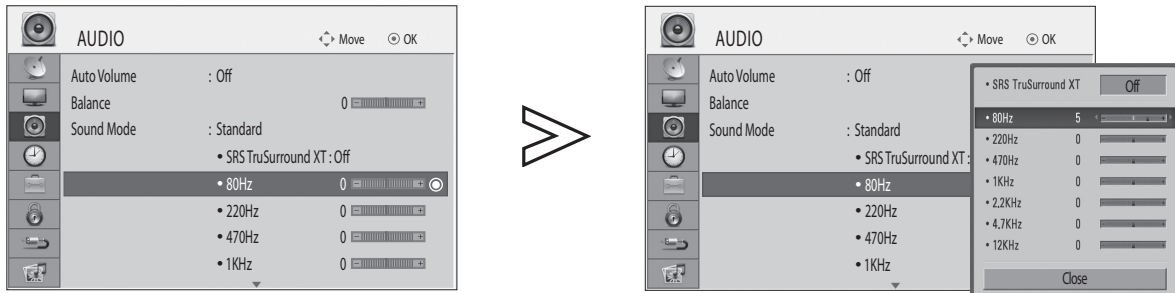

Select **AUDIO**.

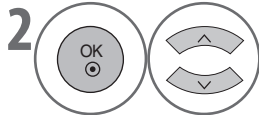

Select **Sound Mode**.

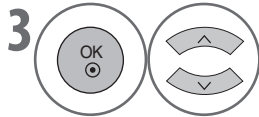

Select **Standard, Music, Cinema, Sport** or **Game**.

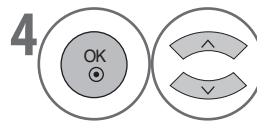

Select a frequency band.

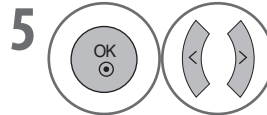

Set the desired sound level.

SRS TRUSURROUND XT

Select this option to sound realistic.

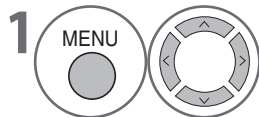

Select **AUDIO**.

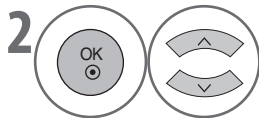

Select **SRS TruSurround XT**.

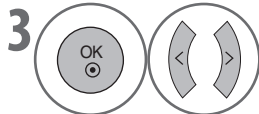

Select **On** or **Off**.

SRS TruSurround XT : TruSurround XT is a patented SRS technology that solves the problem of playing 5.1 multichannel content over two speakers.

▶ **SRS** TruSurround XT is a trademark of SRS Labs, Inc.
▶ TruSurround XT technology is incorporated under license from SRS Labs, Inc.



- Press the **MENU** button to return to normal TV viewing.
- Press the **RETURN** button to return to the previous screen.

SOUND & LANGUAGE CONTROL

BALANCE

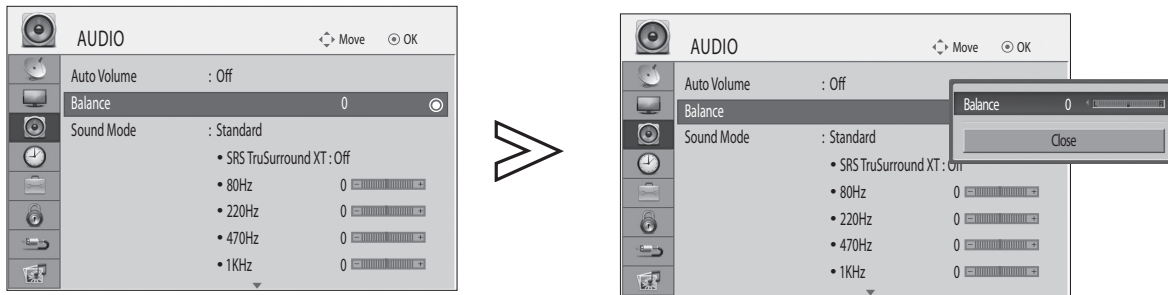
You can adjust the sound balance of the speakers to preferred levels.

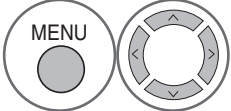
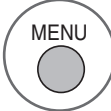
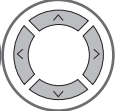
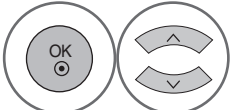
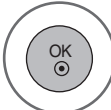
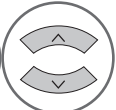
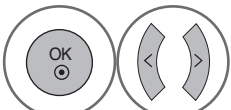

-  **1**   Select **AUDIO**.
-  **2**   Select **Balance**.
-  **3**   Make desired adjustment.

- Press the **MENU** button to return to normal TV viewing.
- Press the **RETURN** button to return to the previous screen.

TV SPEAKERS ON/OFF SETUP

You can adjust the TV internal speaker status.

In **AV1, AV2, AV3, COMPONENT, RGB** and **HDMI1** with HDMI to DVI cable, the TV speaker can be operational even when there is no video signal.

If you wish to use an external Hi-Fi system, turn off the TV internal speakers.

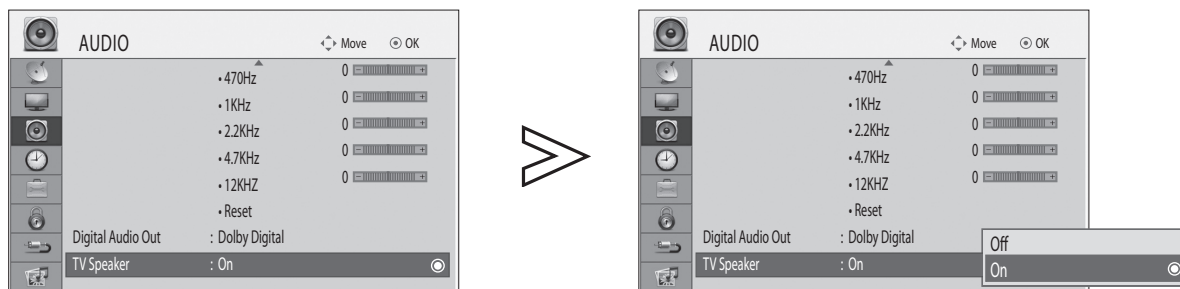

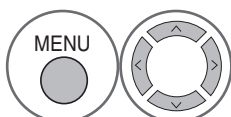
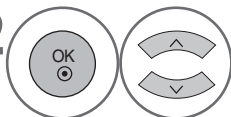
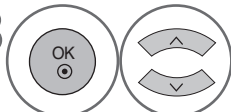
-  Select **AUDIO**.
-  Select **TV Speaker**.
-  Select **On** or **Off**.

- Press the **MENU** button to return to normal TV viewing.
- Press the **RETURN** button to return to the previous screen.

SOUND & LANGUAGE CONTROL

SELECTING DIGITAL AUDIO OUT

This function allows you to select your preferred Digital Audio Output.

The TV can only output Dolby Digital if a channel is broadcast with Dolby Digital audio.

When Dolby digital is available, selecting Dolby Digital in the Digital Audio Out menu will set SPDIF (Sony Philips Digital InterFace) output to Dolby Digital.

If Dolby Digital is selected in the digital audio out menu when dolby digital is not available, SPDIF output will be PCM (Pulse-Code Modulation).

Even if both Dolby Digital and Audio language have been set in a channel which broadcast Dolby Digital Audio, only Dolby Digital will be played.

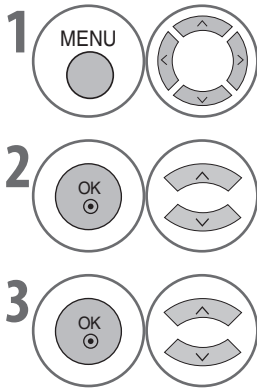
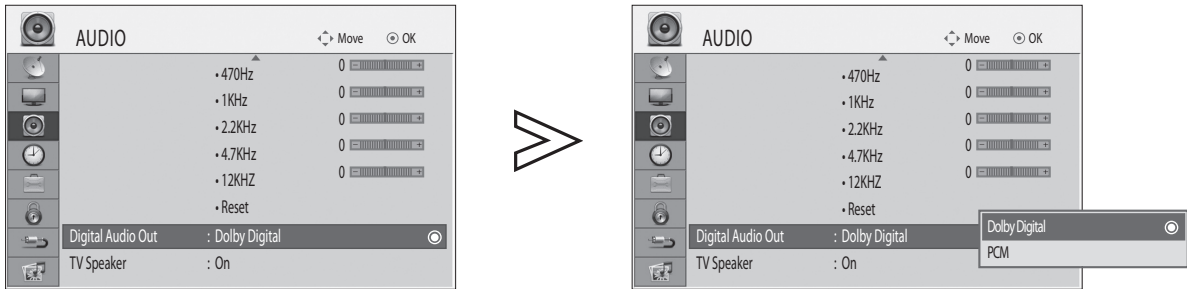

1 Select **AUDIO**.

2 Select **Digital Audio Out**.

3 Select **Dolby Digital** or **PCM**.



Manufactured under license from Dolby Laboratories. *Dolby* and the double-D symbol are trademarks of Dolby Laboratories.

- There is a possibility that when HDMI mode, some DVD players do not make SPDIF sound. At that time, set the output of the digital audio of the DVD player to PCM.





Item	Audio Input	Digital Audio output
Dolby Digital	MPEG	PCM
	DD	DD
	DD+	DD
PCM	MPEG	PCM
	DD	PCM
	DD+	PCM

- Press the **MENU** button to return to normal TV viewing.
- Press the **RETURN** button to return to the previous screen.

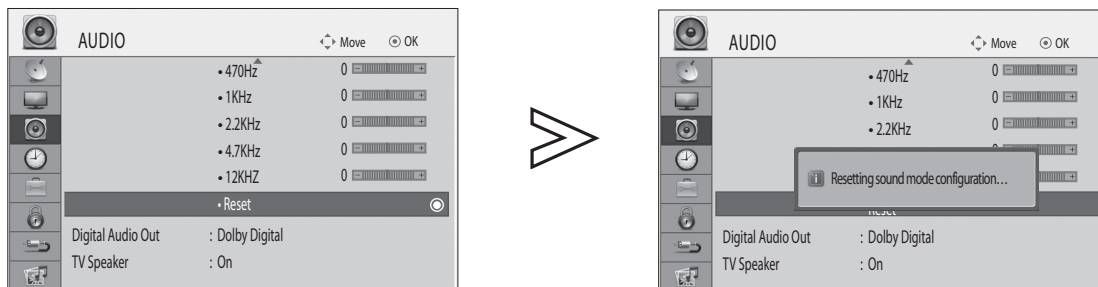
AUDIO RESET

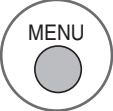
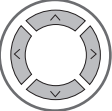
Settings of the selected Sound Mode return to the default factory settings.

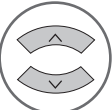

-   Select **AUDIO**.
-   Select **Reset**.
-  Initialize the adjusted value.

- Press the **MENU** button to return to normal TV viewing.
- Press the **RETURN** button to return to the previous screen.

SOUND & LANGUAGE CONTROL

I/II

Stereo/Dual Reception (In Analogue Mode Only)

When a programme is selected, the sound information for the station appears with the programme number and station name.

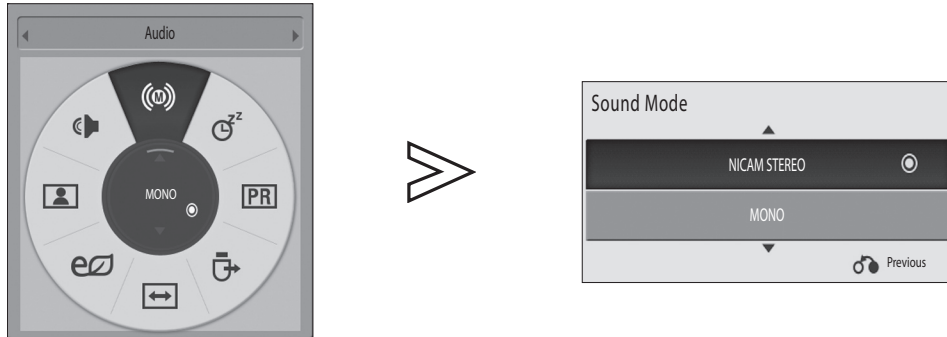

1 Select **AUDIO**.

2 Select the sound output.

Broadcast	On Screen Display
Mono	MONO
Stereo	STEREO
Dual	DUAL I, DUAL II, DUAL I+II

- Mono sound selection**
 If the stereo signal is weak in stereo reception, you can switch to mono. In mono reception, the clarity of sound is improved.
- Language selection for dual language broadcast**
 If a programme can be received in two languages (dual language), you can switch to DUAL I, DUAL II or DUAL I+II.

- DUAL I** Sends the primary broadcast language to the loudspeakers.
- DUAL II** Sends the secondary broadcast language to the loudspeakers.
- DUAL I+II** Sends a separate language to each loudspeaker.

NICAM Reception (In Analogue Mode Only)

If the TV is equipped with a receiver for NICAM reception, high quality NICAM (Near Instantaneous Companding Audio Multiplex) digital sound can be received.

Sound output can be selected according to the type of broadcast received.

- ① When **NICAM** mono is received, you can select **NICAM MONO** or **FM MONO**.
- ② When **NICAM** stereo is received, you can select **NICAM STEREO** or **FM MONO**.
If the stereo signal is weak, switch to **FM MONO**.
- ③ When **NICAM dual** is received, you can select **NICAM DUAL I**, **NICAM DUAL II** or **NICAM DUAL I+II** or **FM MONO**.

Speaker Sound Output Selection

In AV, Component, RGB and HDMI mode, you can select output sound for the left and right loudspeakers.



Select the sound output.

- L+R** Audio signal from audio L input is sent to the left loudspeaker and audio signal from audio R input is sent to the right loudspeaker.
- L+L** Audio signal from audio L input is sent to left and right loudspeakers.
- R+R** Audio signal from audio R input is sent to left and right loudspeakers.

SOUND & LANGUAGE CONTROL

LANGUAGE SELECTION

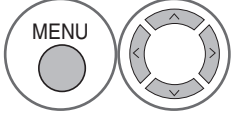
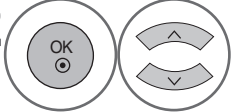
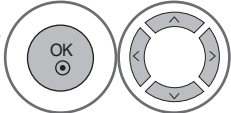
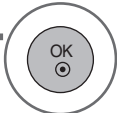
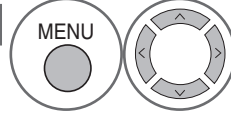
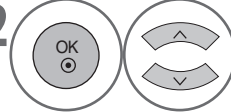
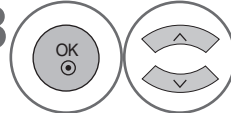
Select the default language and the hard of hearing.

<p>1 </p> <p>2 </p> <p>3 </p> <p>4 </p>	<p>Select OPTION.</p> <p>Select Menu Language, Audio Language or Subtitle Language.</p> <p>Select your desired language.</p> <p>Save.</p>	<p>1 </p> <p>2 </p> <p>3 </p>	<p>Select OPTION.</p> <p>Select Hard of Hearing().</p> <p>Select On or Off.</p>
---	---	--	--

- Press the **MENU** button to return to normal TV viewing.
- Press the **RETURN** button to return to the previous screen.

Audio/Subtitle Language (In Digital Mode Only)

When the languages you selected as the primary for Audio Language and Subtitle Language are not supported, you can select language in secondary category.

If audio data in a selected language is not broadcast, the default language audio will be played. If subtitle data in a selected language is not broadcast, the default language subtitle will be displayed.

< Audio Language Selection >

The Audio function allows selection of a preferred language.

- ▶ When two or more audio languages are roadcast, you can select the audio language.

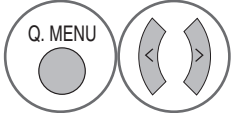
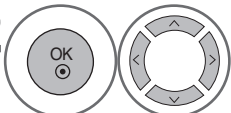
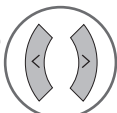



<p>1 </p> <p>2 </p> <p>3 </p>	<p>Select Audio.</p> <p>Select an audio language.</p> <p>Select L+R, L+L or R+R.</p>
---	---

< Subtitle Language Selection >



Use the Subtitle function when two or more subtitle languages are broadcast.

- ▶ When two or more subtitle languages are broadcast, you can select the subtitle language with the **SUBTITLE** button on the remote control.
- ▶ Press the $\wedge \vee$ button to select a subtitle language.

Audio Language OSD Information

Display	Status
N.A	Not Available
	MPEG Audio
	Dolby Digital Audio
	Audio for "Visual Impaired"
	Audio for "Hearing Impaired"

Subtitle Language OSD Information

Display	Status
N.A	Not Available
	Teletext Subtitle
	Subtitle for "Hard of Hearing"

TIME SETTING

CLOCK SETUP

The clock is set automatically when receiving a digital TV signal.
Once Clock is set in DTV mode, you cannot change time.
(You can set the clock manually only if the TV has no DTV signal.)
You must set the time correctly before using on/off timer function.

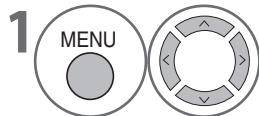
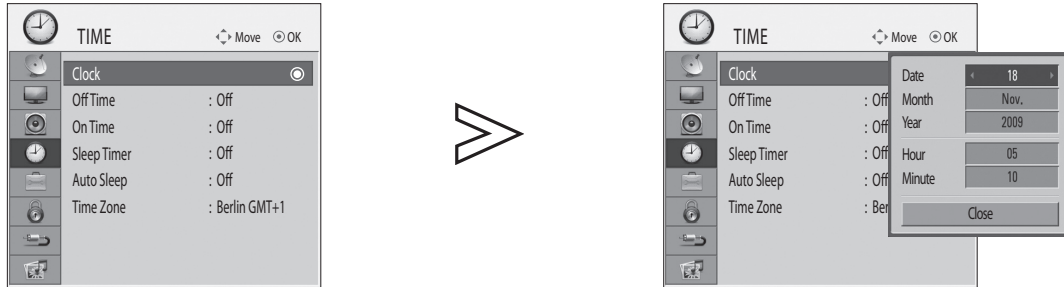

Select **TIME**.

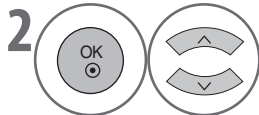

Select **Clock**.

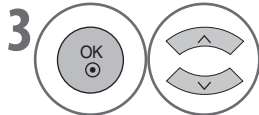

Select either the year, date, or time option.



Set the year, date, and time options..

- Press the **MENU** button to return to normal TV viewing.
- Press the **RETURN** button to return to the previous screen.

TIME SETTING

AUTO ON/OFF TIME SETTING







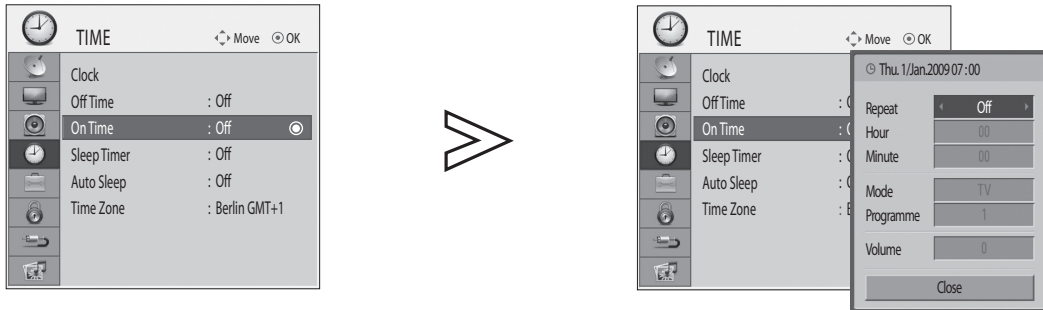

The Off time function automatically switches the TV to standby at a preset time.

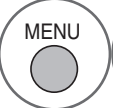
Two hours after the TV is switched on by the on time function it will automatically switch back to standby mode unless a button has been pressed.

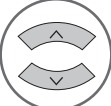

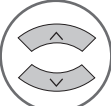
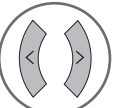
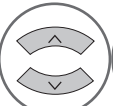

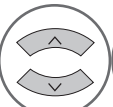
The Off time function overrides the On timer function if both are set to the same time.

The TV must be in standby mode for the On timer to work.

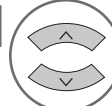

- 1   Select **TIME**.
- 2   Select **Off Time** or **On Time**.
- 3   Select **Repeat**.
- 4  Select **Off, Once, Daily, Mon~Fri, Mon~Sat, Sat~Sun** or **Sun**.
- 5   Set the hour.
- 6   Set the minutes.

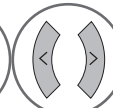
- To cancel **On/Off Time** function, select **Off**.
- For On Time function only

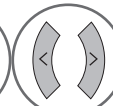
- 1  Select **Mode**.
- 2  Select **TV** or **DTV**.
- 3   Set the programme.
- 4   Adjust volume level at switch-on.

- Press the **MENU** button to return to normal TV viewing.
- Press the **RETURN** button to return to the previous screen.

AUTO SHUT-OFF SETTING

If the TV is switched on and there is no input signal, it will switch off automatically after 15 minutes.

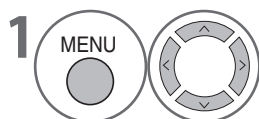
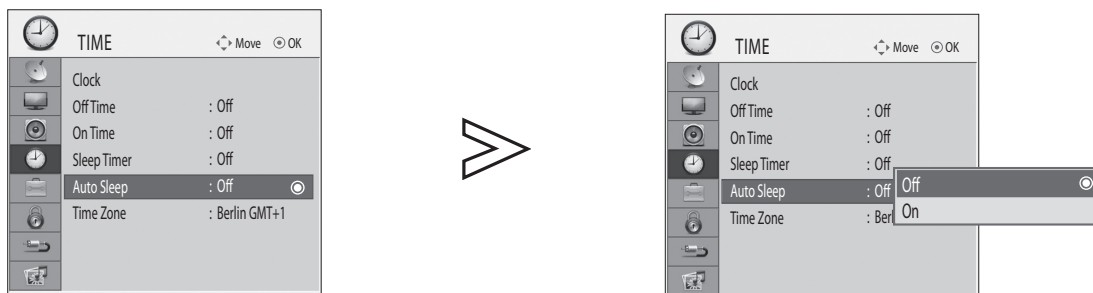

Select **TIME**.

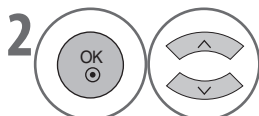

Select **Auto Sleep**.

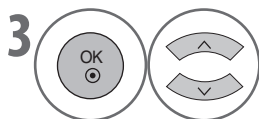

Select **Off** or **On**.

- Press the **MENU** button to return to normal TV viewing.
- Press the **RETURN** button to return to the previous screen.

SLEEP TIMER SETTING

You do not have to remember to switch the TV off before you go to sleep.

The sleep timer automatically switches the TV to standby after the preset time has elapsed.

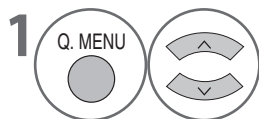

Select **Sleep Timer**.

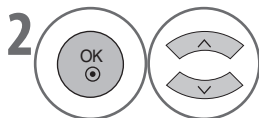

Select **Off, 10, 20, 30, 60, 90, 120, 180** or **240 Min.**

- When you switch the TV off, the preset sleep timer is cancelled.
- You can also adjust **Sleep Timer** in the **TIME** menu.

TIME SETTING

TIME ZONE SETTING

You can select the time zone of your region.

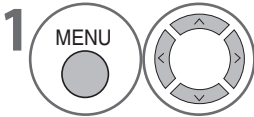
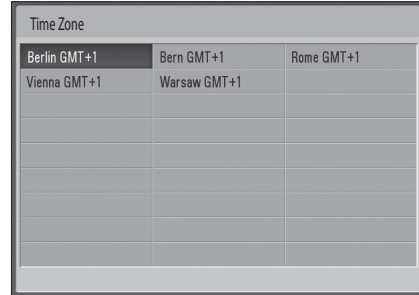
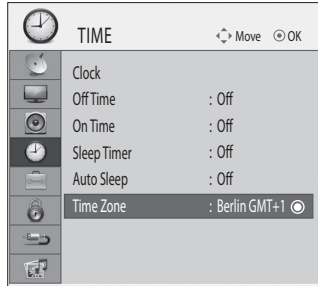

Select **TIME**.

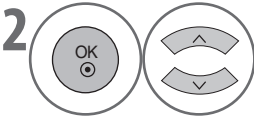

Select **Time Zone**.

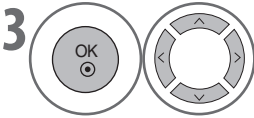

Select the time zone.

- Press the **MENU** button to return to normal TV viewing.
- Press the **RETURN** button to return to the previous screen.

PARENTAL CONTROL / RATINGS

SET PASSWORD & LOCK SYSTEM

Enter the password, press '0', '0', '0', '0' on the remote control handset.

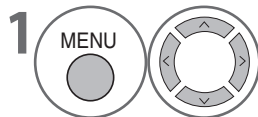
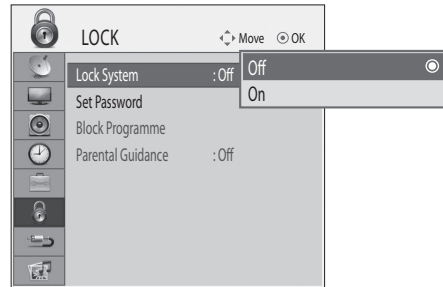

Select **LOCK**.

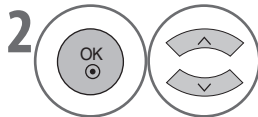

Select **Lock System**.

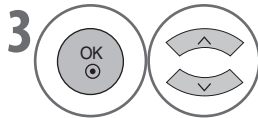

Select **On**.

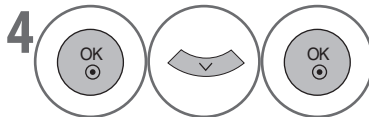

Set the password.



Input a 4-digit password.
Be sure to remember this number!
Re-enter new password for confirm.

- If you have selected **On** in **LOCK > Lock System** menu, you will be prompted to enter your password to access. Use **NUMBER** buttons to input a 4-digit password.
- If you have forgotten your password, press 7777 to reset your password.

- Press the **MENU** button to return to normal TV viewing.
- Press the **RETURN** button to return to the previous screen.

PARENTAL CONTROL / RATINGS

BLOCK PROGRAMME

Blocks any programmes that you do not want to watch or that you do not want your children to watch.

It is available to use this function in **Lock System "On"**.

Enter a password to watch a blocked programme.

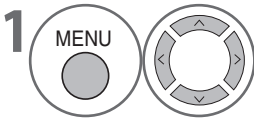
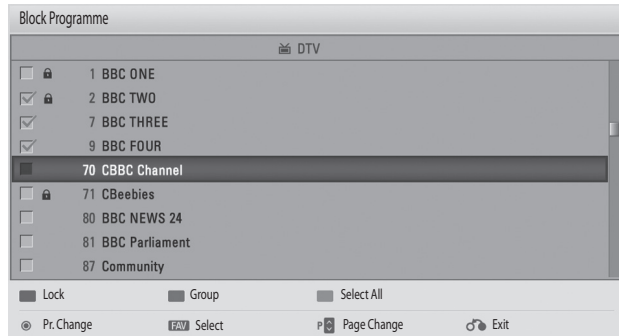
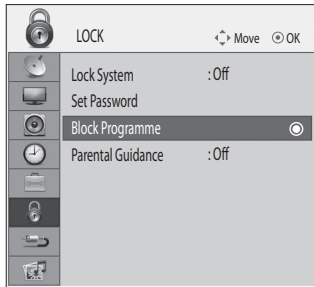

Select **LOCK**.

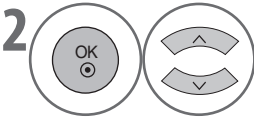

Select **Block Programme**.



Enter the **Block Programme**.



Select a programme to be locked/unlocked.



Lock or Unlock.

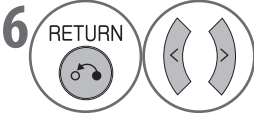

Select **OK** to save all the changes.



Save.

- If you have selected **On** in **LOCK > Lock System** menu, you will be prompted to enter your password to access. Use **NUMBER** buttons to input a 4-digit password.
- The  icon will be displayed when the channel is locked.
- In Analogue Antenna mode, it will be saved automatically without the confirm message.

- Press the **MENU** button to return to normal TV viewing.
- Press the **RETURN** button to return to the previous screen.

PARENTAL CONTROL (IN DIGITAL MODE ONLY)

This function operates according to information from the broadcasting station. Therefore if the signal has incorrect information, this function does not operate.

A password is required to gain access to this menu.

This set is programmed to remember which option it was last set to even if you switch the set off.

Prevents children from watching certain adult's TV programmes, according to the ratings limit set.

Enter a password to watch a blocked programme.

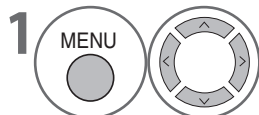
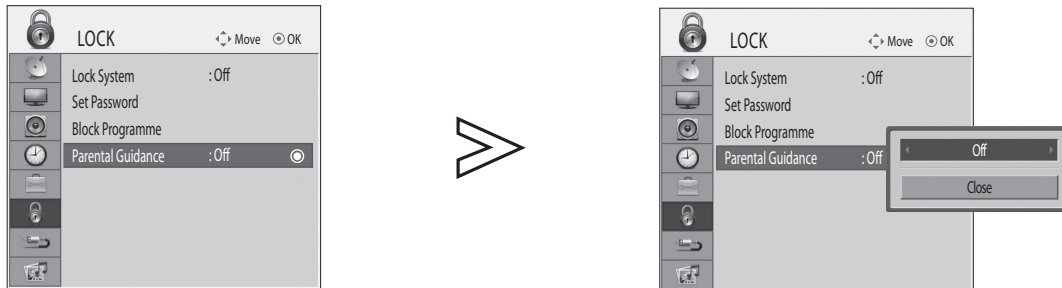

Select **LOCK**.

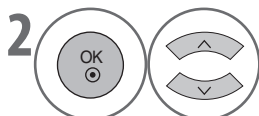

Select **Parental Guidance**.

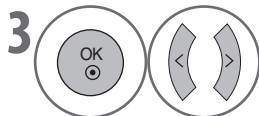

Make appropriate adjustments.



Save.

- If you have selected **On** in **LOCK > Lock System** menu, you will be prompted to enter your password to access. Use **NUMBER** buttons to input a 4-digit password.
- If you have forgotten your password, press 7777 to reset your password.
- If **Parental Guidance** is set, a programme without parental rating will be blocked.

- Press the **MENU** button to return to normal TV viewing.
- Press the **RETURN** button to return to the previous screen.

PARENTAL CONTROL / RATINGS

KEY LOCK

The TV can be set so that the remote control is required to control it. This feature can be used to prevent unauthorized viewing.

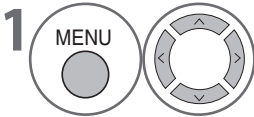
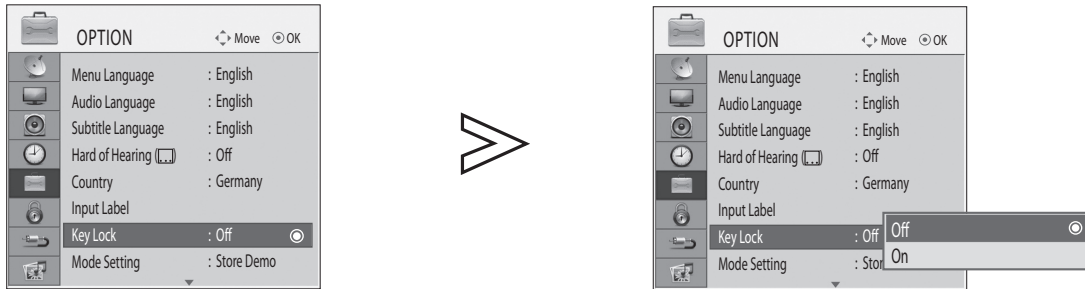

Select **OPTION**.

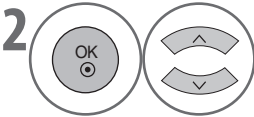

Select **Key Lock**.

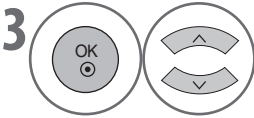

Select **On** or **Off**.



Save.

- In **Key Lock 'On'**, if the TV is turned off, press the **INPUT, P ^ v** button on the TV or **POWER, INPUT, P ^ v** or **NUMBER** buttons on the remote control then the TV will be turned on.
- With the **Key Lock On**, the display '**⚠ Key Lock On**' appears on the screen if any button on the front panel is pressed while viewing the TV.

- Press the **MENU** button to return to normal TV viewing.
- Press the **RETURN** button to return to the previous screen.

TELETEXT

* **This feature is not available in all countries.**

Teletext is a free service broadcast by most TV stations which gives up-to-the-minute information on news, weather, television programmes, share prices and many other topics.

The teletext decoder of this TV can support the SIMPLE and FASTEXT systems. SIMPLE (standard teletext) consists of a number of pages which are selected by directly entering the corresponding page number. FASTEXT is more modern method allowing quick and easy selection of teletext information.

SWITCH ON/OFF

Press the **TEXT** button to switch to teletext. The initial page or last page viewed appears on the screen.

Two page numbers, TV station name, date and time are displayed on the screen headline. The first page number indicates your selection, while the second shows the current page displayed.

Press the **TEXT** button to switch off teletext. The previous mode reappears.

SIMPLE TEXT

■ Page selection

- 1 Enter the desired page number as a three digit number with the **NUMBER** buttons. If during selection you press a wrong number, you must complete the three digit number and then re-enter the correct page number.
- 2 The **P** \wedge \vee button can be used to select the preceding or following page.

FASTEXT

The teletext pages are colour coded along the bottom of the screen and are selected by pressing the corresponding coloured button.

■ Page selection

- 1 Press the **T.OPT** button and then use \wedge \vee button to select $\boxed{\text{I}}$ menu. Display the index page.
- 2 You can select the pages which are colour coded along the bottom line with corresponding coloured buttons.
- 3 As with SIMPLE teletext mode, you can select a page by entering its three digit page number with the NUMBER buttons in FASTEXT mode.
- 4 The **P** \wedge \vee button can be used to select the preceding or following page.

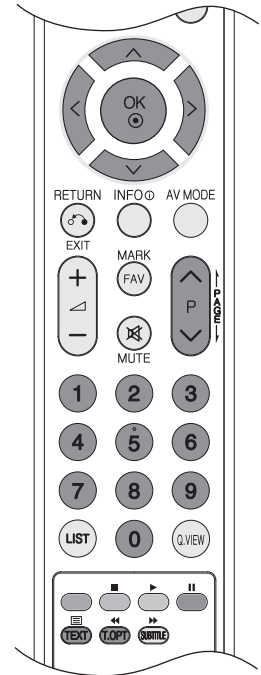

TELETEXT

SPECIAL TELETEXT FUNCTIONS

Press the **T. OPT** button and then use \wedge \vee button to select the **Text Option** menu.



- **Size**
Selects double height text.



- **Index**
Displays the index page.



- **Time**
In the teletext mode, press this button to select a sub page number. The sub page number is displayed at the bottom of the screen. To hold or change the sub page, press the RED/GREEN or NUMBER buttons.



- **Hold**
Stops the automatic page change which will occur if a teletext page consists of 2 or more sub pages. The number of sub pages and the sub page displayed is, usually, shown on the screen below the time. When this menu is selected the stop symbol is displayed at the top left-hand corner of the screen and the automatic page change is inactive.



- **Reveal**
Select this menu to display concealed information, such as solutions to riddles or puzzles.



- **Update**
Displays the TV picture on the screen while waiting for a new teletext page. The display will appear at the top left hand corner of the screen. When the updated page is available then display will change to the page number. Select this menu again to view the updated teletext page.

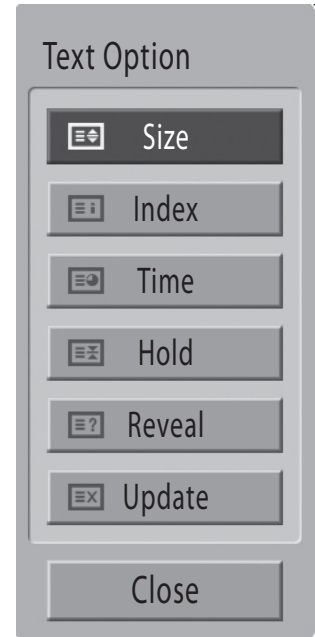

APPENDIX

TROUBLESHOOTING

The TV does not operate properly.	
The remote control does not work	<ul style="list-style-type: none"> - Check to see if there is any object between the TV and the remote control causing an obstruction. Ensure you are pointing the remote control directly at the TV. - Ensure that the batteries are installed with correct polarity (+ to +, - to -). - Install new batteries.
Power is suddenly turned off	<ul style="list-style-type: none"> - Is the sleep timer set? - Check the power control settings. Has the Power supply been interrupted. - If the TV is switched on and there is no input signal, it will switch off automatically after 15 minutes.

The video function does not work.	
No picture & No sound	<ul style="list-style-type: none"> - Check whether the TV is switched on. - Try another channel. The problem may be with the broadcast. - Is the power cord inserted correctly into the mains? - Check your antenna direction and/or location. - Test the mains outlet by plugging another product into the same outlet.
Picture appears slowly after switching on	<ul style="list-style-type: none"> - This is normal, the image is muted during the TV startup process. Please contact your service centre, if the picture has not appeared after five minutes.
No or poor colour or poor picture	<ul style="list-style-type: none"> - Adjust Colour in menu option. - Allow a sufficient distance between the TV and the VCR. - Try another channel. The problem may be with the broadcast. - Are the video cables installed properly? - Activate any function to restore the brightness of the picture.
Horizontal/vertical bars or picture shaking	<ul style="list-style-type: none"> - Check for local interference such as an electrical appliance or power tool.
Poor reception on some channels	<ul style="list-style-type: none"> - Station or cable channel experiencing problems, tune to another station. - Station signal is weak, reposition the antenna to receive weaker stations. - Check for sources of possible interference.
Lines or streaks in pictures	<ul style="list-style-type: none"> - Check antenna (Change the position of the antenna).
No picture when connecting HDMI	<ul style="list-style-type: none"> - Check that your HDMI cable is version 1.3 or higher. - If the HDMI cables don't support HDMI version 1.3, flicking or no screen display can result. Please use the latest cables that support at least HDMI version 1.3.

The audio function does not work.	
Picture OK & No sound	<ul style="list-style-type: none"> - Press the  + or - button. - Sound muted? Press MUTE button. - Try another channel. The problem may be with the broadcast. - Are the audio cables installed properly?
No output from one of the speakers	<ul style="list-style-type: none"> - Adjust Balance in menu option.
Unusual sound from inside the TV	<ul style="list-style-type: none"> - A change in ambient humidity or temperature may result in an unusual noise when the TV is switched on or off and does not indicate a fault with the TV.
No sound when connecting HDMI or USB	<ul style="list-style-type: none"> - Check HDMI cable over version 1.3. - Check USB cable over version 2.0.

APPENDIX

There is a problem in PC mode. (Only PC mode applied)	
The signal is out of range (Invalid format)	- Adjust resolution, horizontal frequency, or vertical frequency. - Check the input source.
Vertical bar or stripe on background & Horizontal Noise & Incorrect position	- Use Auto configure or adjust clock, phase, or H/V position. (Option)
Screen colour is unstable or single colour	- Check the signal cable. - Reinstall the PC video card.

There is a problem with PICTURE settings.	
When the user changes the picture settings, the TV automatically converts back to the initial settings after a certain period of time.	- It means that the TV is currently set to Store Demo mode. To switch to Home use mode you should do the followings: From the TV Menu, choose OPTION -> Choose Mode Setting -> Choose Home use . Now, you have completed switching to the Home use mode.

MAINTENANCE

Early malfunctions can be prevented. Careful and regular cleaning can prolong the life of your new TV.

Caution:

- ▶ Be sure to switch the power off and unplug the power cord before you begin any cleaning.

Cleaning the Screen

- 1 A good way to keep the dust off your screen for a while is to wet a soft cloth in a mixture of lukewarm water and a little fabric softener or dish washing detergent. Wring the cloth until it is almost dry, and then use it to wipe the screen.
- 2 Ensure there is no excess water on the screen. Allow any water or dampness to evaporate before switching on.

Cleaning the Cabinet

- To remove dirt or dust, wipe the cabinet with a soft, dry, lint-free cloth.
- Do not to use a wet cloth.

Extended Absence

CAUTION

- ▶ If you expect to leave your TV dormant for prolonged periods (such as a holiday), unplug the power cord to protect against possible damage from lightning or power surges.

PRODUCT SPECIFICATIONS

MODELS		32LF57**	42LF57**	32LH57**	42LH57**
		32LF5700-ZE	42LF5700-ZE	32LH5700-ZC	42LH5700-ZC
Dimensions (W x H x D)	with stand	813.8 x 598.8 x 231.9 mm 32.0 x 23.5 x 9.1 inches	1034.0 x 735.0 x 294.0 mm 40.7 x 28.9 x 11.5 inches	815.0 x 583.8 x 223.8 mm 32.1 x 23.0 x 8.8 inches	1052.2 x 719.1 x 296.2 mm 41.5 x 28.3 x 11.7 inches
	without stand	813.8 x 540.4 x 78.9 mm 32.0 x 21.2 x 3.1 inches	1034.0 x 663.0 x 92.0 mm 40.7 x 26.1 x 3.6 inches	815.0 x 529.6 x 82.0 mm 32.1 x 20.9 x 3.2 inches	1052.2 x 657.3 x 90.8 mm 41.5 x 25.9 x 3.6 inches
Weight	with stand	12.6 Kg / 27.8 lbs	20.1 Kg / 44.31 lbs	12.6 Kg / 27.8 lbs	19 Kg / 41.9 lbs
	without stand	11.2 Kg / 24.7 lbs	17.5 Kg / 38.6 lbs	11.4 Kg / 25.2 lbs	17.2 Kg / 37.9 lbs
Power requirement Power Consumption		AC100~240V~50/60Hz 175W max	AC100~240V~50/60Hz 220W max	AC100~240V~50/60Hz 175W max	AC100~240V~50/60Hz 220W max
CI Module Size (Width x Height x Depth)		100.0 x 55.0 x 5.0mm 3.94 x 2.17 x 0.20inches			
Television System Programme Coverage External Antenna Impedance		PAL I, PAL/SECAM BG/DK VHF: E2 ~ E12, UHF: E21 ~ E69, CATV: S1 ~ S20, HYPER: S21 ~ S47 75 Ω			
Environment condition	Operating Temperature Operating Humidity	0 ~ 40°C / 32 ~ 104°F Less than 80%			
	Storage Temperature Storage Humidity	-20 ~ 60°C / -4 ~ 140°F Less than 85%			

- The specifications shown above may be changed without prior notice for quality improvement.

APPENDIX

OPEN SOURCE LICENSE

OPEN SOURCE SOFTWARE NOTICE

The following GPL executables and LGPL libraries used in this product are subject to the GPL2.0/LGPL2.1 License Agreements:

GPL EXECUTABLES:

- Linux kernel 2.6
- busybox
- freetype

LGPL LIBRARIES:

- glibc
- libexif
- id3lib

LG Electronics offers to provide source code to you on CD-ROM for a charge covering the cost of performing such distribution, such as the cost of media, shipping and handling upon e-mail request to LG Electronics at: Opensource@lge.com

This offer is valid for a period of three(3) years from the date of the distribution of this product by LG Electronics. You can obtain a copy of the GPL and LGPL licenses at next pages.

<http://www.gnu.org/licenses/old-licenses/gpl-2.0.html>

Also you can obtain the translation of GPL, LGPL licenses from <http://www.gnu.org/licenses/old-licenses/gpl-2.0-translations.html>, <http://www.gnu.org/licenses/old-licenses/lgpl-2.1-translations.html>.

- This software is based in part on the work of the Independent JPEG Group.
- This software includes the libpng, PNG reference library.
- This software includes the Zlib compression library, developed by Jean-loup Gailly and Mark Adler. Copyright (C) 1995-2005 Jean-loup Gailly and Mark Adler

GNU GENERAL PUBLIC LICENSE

Version 2, June 1991

Copyright (C) 1989, 1991 Free Software Foundation, Inc., 51 Franklin Street, Fifth Floor, Boston, MA 02110-1301 USA
Everyone is permitted to copy and distribute verbatim copies of this license document, but changing it is not allowed.

Preamble

The licenses for most software are designed to take away your freedom to share and change it. By contrast, the GNU General Public License is intended to guarantee your freedom to share and change free software--to make sure the software is free for all its users. This General Public License applies to most of the Free Software Foundation's software and to any other program whose authors commit to using it. (Some other Free Software Foundation software is covered by the GNU Lesser General Public License instead.) You can apply it to your programs, too.

When we speak of free software, we are referring to freedom, not price. Our General Public Licenses are designed to make sure that you have the freedom to distribute copies of free software (and charge for this service if you wish), that you receive source code or can get it if you want it, that you can change the software or use pieces of it in new free programs; and that you know you can do these things.

To protect your rights, we need to make restrictions that forbid anyone to deny you these rights or to ask you to surrender the rights. These restrictions translate to certain responsibilities for you if you distribute copies of the software, or if you modify it.

For example, if you distribute copies of such a program, whether gratis or for a fee, you must give the recipients all the rights that you have. You must make sure that they, too, receive or can get the source code. And you must show them these terms so they know their rights.

We protect your rights with two steps: (1) copyright the software, and (2) offer you this license which gives you legal permission to copy, distribute and/or modify the software.

Also, for each author's protection and ours, we want to make certain that everyone understands that there is no warranty for this free software. If the software is modified by someone else and passed on, we want its recipients to know that what they have is not the original, so that any problems introduced by others will not reflect on the original authors' reputations.

Finally, any free program is threatened constantly by software patents. We wish to avoid the danger that redistributors of a free program will individually obtain patent licenses, in effect making the program proprietary. To prevent this, we have made it clear that any patent must be licensed for everyone's free use or not licensed at all.

The precise terms and conditions for copying, distribution and modification follow.

GNU GENERAL PUBLIC LICENSE

TERMS AND CONDITIONS FOR COPYING, DISTRIBUTION AND MODIFICATION

0. This License applies to any program or other work which contains a notice placed by the copyright holder saying it may be distributed under the terms of this General Public License. The "Program", below, refers to any such program or work, and a "work based on the Program" means either the Program or any derivative work under copyright law: that is to say, a work containing the Program or a portion of it, either verbatim or with modifications and/or translated into another language. (Hereinafter, translation is included without limitation in the term "modification".) Each licensee is addressed as "you".

Activities other than copying, distribution and modification are not covered by this License; they are outside its scope.

The act of running the Program is not restricted, and the output from the Program is covered only if its contents constitute a work based on the Program (independent of having been made by running the Program). Whether that is true depends on what the Program does.

APPENDIX

1. You may copy and distribute verbatim copies of the Program's source code as you receive it, in any medium, provided that you conspicuously and appropriately publish on each copy an appropriate copyright notice and disclaimer of warranty; keep intact all the notices that refer to this License and to the absence of any warranty; and give any other recipients of the Program a copy of this License along with the Program.

You may charge a fee for the physical act of transferring a copy, and you may at your option offer warranty protection in exchange for a fee.

2. You may modify your copy or copies of the Program or any portion of it, thus forming a work based on the Program, and copy and distribute such modifications or work under the terms of Section 1 above, provided that you also meet all of these conditions:

- a) You must cause the modified files to carry prominent notices stating that you changed the files and the date of any change.
- b) You must cause any work that you distribute or publish, that in whole or in part contains or is derived from the Program or any part thereof, to be licensed as a whole at no charge to all third parties under the terms of this License.
- c) If the modified program normally reads commands interactively when run, you must cause it, when started running for such interactive use in the most ordinary way, to print or display an announcement including an appropriate copyright notice and a notice that there is no warranty (or else, saying that you provide a warranty) and that users may redistribute the program under these conditions, and telling the user how to view a copy of this License. (Exception: if the Program itself is interactive but does not normally print such an announcement, your work based on the Program is not required to print an announcement.)

These requirements apply to the modified work as a whole. If identifiable sections of that work are not derived from the Program, and can be reasonably considered independent and separate works in themselves, then this License, and its terms, do not apply to those sections when you distribute them as separate works. But when you distribute the same sections as part of a whole which is a work based on the Program, the distribution of the whole must be on the terms of this License, whose permissions for other licensees extend to the entire whole, and thus to each and every part regardless of who wrote it.

Thus, it is not the intent of this section to claim rights or contest your rights to work written entirely by you; rather, the intent is to exercise the right to control the distribution of derivative or collective works based on the Program.

In addition, mere aggregation of another work not based on the Program with the Program (or with a work based on the Program) on a volume of a storage or distribution medium does not bring the other work under the scope of this License.

3. You may copy and distribute the Program (or a work based on it, under Section 2) in object code or executable form under the terms of Sections 1 and 2 above provided that you also do one of the following:

- a) Accompany it with the complete corresponding machine-readable source code, which must be distributed under the terms of Sections 1 and 2 above on a medium customarily used for software interchange; or,
- b) Accompany it with a written offer, valid for at least three years, to give any third party, for a charge no more than your cost of physically performing source distribution, a complete machine-readable copy of the corresponding source code, to be distributed under the terms of Sections 1 and 2 above on a medium customarily used for software interchange; or,
- c) Accompany it with the information you received as to the offer to distribute corresponding source code. (This alternative is allowed only for noncommercial distribution and only if you received the program in object code or executable form with such an offer, in accord with Subsection b above.)

The source code for a work means the preferred form of the work for making modifications to it. For an executable work, complete source code means all the source code for all modules it contains, plus any associated interface definition files, plus the scripts used to control compilation and installation of the executable. However, as a special exception, the source code distributed need not include anything that is normally distributed (in either source or binary form) with the major components (compiler, kernel, and so on) of the operating system on which the executable runs, unless that component itself accompanies the executable.

If distribution of executable or object code is made by offering access to copy from a designated place, then offering equivalent access to copy the source code from the same place counts as distribution of the source code, even though third parties are not compelled to copy the source along with the object code.

4. You may not copy, modify, sublicense, or distribute the Program except as expressly provided under this License. Any attempt otherwise to copy, modify, sublicense or distribute the Program is void, and will automatically terminate your rights under this License. However, parties who have received copies, or rights, from you under this License will not have their licenses terminated so long as such parties remain in full compliance.

5. You are not required to accept this License, since you have not signed it. However, nothing else grants you permission to modify or distribute the Program or its derivative works. These actions are prohibited by law if you do not accept this License. Therefore, by modifying or distributing the Program (or any work based on the Program), you indicate your acceptance of this License to do so, and all its terms and conditions for copying, distributing or modifying the Program or works based on it.

6. Each time you redistribute the Program (or any work based on the Program), the recipient automatically receives a license from the original licensor to copy, distribute or modify the Program subject to these terms and conditions. You may not impose any further restrictions on the recipients' exercise of the rights granted herein. You are not responsible for enforcing compliance by third parties to this License.

7. If, as a consequence of a court judgment or allegation of patent infringement or for any other reason (not limited to patent issues), conditions are imposed on you (whether by court order, agreement or otherwise) that contradict the conditions of this License, they do not excuse you from the conditions of this License. If you cannot distribute so as to satisfy simultaneously your obligations under this License and any other pertinent obligations, then as a consequence you may not distribute the Program at all. For example, if a patent license would not permit royalty-free redistribution of the Program by all those who receive copies directly or indirectly through you, then the only way you could satisfy both it and this License would be to refrain entirely from distribution of the Program.

If any portion of this section is held invalid or unenforceable under any particular circumstance, the balance of the section is intended to apply and the section as a whole is intended to apply in other circumstances.

It is not the purpose of this section to induce you to infringe any patents or other property right claims or to contest validity of any such claims; this section has the sole purpose of protecting the integrity of the free software distribution system, which is implemented by public license practices. Many people have made generous contributions to the wide range of software distributed through that system in reliance on consistent application of that system; it is up to the author/donor to decide if he or she is willing to distribute software through any other system and a licensee cannot impose that choice.

This section is intended to make thoroughly clear what is believed to be a consequence of the rest of this License.

8. If the distribution and/or use of the Program is restricted in certain countries either by patents or by copyrighted interfaces, the original copyright holder who places the Program under this License may add an explicit geographical distribution limitation excluding those countries, so that distribution is permitted only in or among countries not thus excluded. In such case, this License incorporates the limitation as if written in the body of this License.

9. The Free Software Foundation may publish revised and/or new versions of the General Public License from time to time. Such new versions will be similar in spirit to the present version, but may differ in detail to address new problems or concerns.

Each version is given a distinguishing version number. If the Program specifies a version number of this License which applies to it and "any later version", you have the option of following the terms and conditions either of that version or of any later version published by the Free Software Foundation. If the Program does not specify a version number of this License, you may choose any version ever published by the Free Software Foundation.

10. If you wish to incorporate parts of the Program into other free programs whose distribution conditions are different, write to the author to ask for permission. For software which is copyrighted by the Free Software Foundation, write to the Free Software Foundation; we sometimes make exceptions for this. Our decision will be guided by the two goals of preserving the free status of all derivatives of our free software and of promoting the sharing and reuse of software generally.

APPENDIX

NO WARRANTY

11. BECAUSE THE PROGRAM IS LICENSED FREE OF CHARGE, THERE IS NO WARRANTY FOR THE PROGRAM, TO THE EXTENT PERMITTED BY APPLICABLE LAW. EXCEPT WHEN OTHERWISE STATED IN WRITING THE COPYRIGHT HOLDERS AND/OR OTHER PARTIES PROVIDE THE PROGRAM "AS IS" WITHOUT WARRANTY OF ANY KIND, EITHER EXPRESSED OR IMPLIED, INCLUDING, BUT NOT LIMITED TO, THE IMPLIED WARRANTIES OF MERCHANTABILITY AND FITNESS FOR A PARTICULAR PURPOSE. THE ENTIRE RISK AS TO THE QUALITY AND PERFORMANCE OF THE PROGRAM IS WITH YOU. SHOULD THE PROGRAM PROVE DEFECTIVE, YOU ASSUME THE COST OF ALL NECESSARY SERVICING, REPAIR OR CORRECTION.

12. IN NO EVENT UNLESS REQUIRED BY APPLICABLE LAW OR AGREED TO IN WRITING WILL ANY COPYRIGHT HOLDER, OR ANY OTHER PARTY WHO MAY MODIFY AND/OR REDISTRIBUTE THE PROGRAM AS PERMITTED ABOVE, BE LIABLE TO YOU FOR DAMAGES, INCLUDING ANY GENERAL, SPECIAL, INCIDENTAL OR CONSEQUENTIAL DAMAGES ARISING OUT OF THE USE OR INABILITY TO USE THE PROGRAM (INCLUDING BUT NOT LIMITED TO LOSS OF DATA OR DATA BEING RENDERED INACCURATE OR LOSSES SUSTAINED BY YOU OR THIRD PARTIES OR A FAILURE OF THE PROGRAM TO OPERATE WITH ANY OTHER PROGRAMS), EVEN IF SUCH HOLDER OR OTHER PARTY HAS BEEN ADVISED OF THE POSSIBILITY OF SUCH DAMAGES.

END OF TERMS AND CONDITIONS

How to Apply These Terms to Your New Programs

If you develop a new program, and you want it to be of the greatest possible use to the public, the best way to achieve this is to make it free software which everyone can redistribute and change under these terms.

To do so, attach the following notices to the program. It is safest to attach them to the start of each source file to most effectively convey the exclusion of warranty; and each file should have at least the "copyright" line and a pointer to where the full notice is found.

```
<one line to give the program's name and a brief idea of what it does.>
Copyright (C) <year> <name of author>
```

```
This program is free software; you can redistribute it and/or modify it under the terms of the GNU General Public License as published by the Free Software Foundation; either version 2 of the License, or (at your option) any later version.
```

```
This program is distributed in the hope that it will be useful, but WITHOUT ANY WARRANTY; without even the implied warranty of MERCHANTABILITY or FITNESS FOR A PARTICULAR PURPOSE. See the GNU General Public License for more details.
```

```
You should have received a copy of the GNU General Public License along with this program; if not, write to the Free Software Foundation, Inc., 51 Franklin Street, Fifth Floor, Boston, MA 02110-1301 USA.
```

Also add information on how to contact you by electronic and paper mail.

If the program is interactive, make it output a short notice like this when it starts in an interactive mode:

```
Gnomovision version 69, Copyright (C) year name of author Gnomovision comes with ABSOLUTELY NO WARRANTY; for details type `show w'. This is free software, and you are welcome to redistribute it under certain conditions; type `show c' for details.
```

The hypothetical commands `show w' and `show c' should show the appropriate parts of the General Public License. Of course, the commands you use may be called something other than `show w' and `show c'; they could even be mouse-clicks or menu items--whatever suits your program.

You should also get your employer (if you work as a programmer) or your school, if any, to sign a "copyright disclaimer" for the program, if necessary. Here is a sample; alter the names:

```
Yoyodyne, Inc., hereby disclaims all copyright interest in the program `Gnomovision' (which makes passes at compilers) written by James Hacker.
```

```
<signature of Ty Coon>, 1 April 1989
Ty Coon, President of Vice
```

This General Public License does not permit incorporating your program into proprietary programs. If your program is a subroutine library, you may consider it more useful to permit linking proprietary applications with the library. If this is what you want to do, use the GNU Lesser General Public License instead of this License.

GNU LESSER GENERAL PUBLIC LICENSE
Version 2.1, February 1999

Copyright (C) 1991, 1999 Free Software Foundation, Inc. 51 Franklin Street, Fifth Floor, Boston, MA 02110-1301 USA
Everyone is permitted to copy and distribute verbatim copies of this license document, but changing it is not allowed.

[This is the first released version of the Lesser GPL. It also counts as the successor of the GNU Library Public License, version 2, hence the version number 2.1.]

Preamble

The licenses for most software are designed to take away your freedom to share and change it. By contrast, the GNU General Public Licenses are intended to guarantee your freedom to share and change free software--to make sure the software is free for all its users.

This license, the Lesser General Public License, applies to some specially designated software packages--typically libraries--of the Free Software Foundation and other authors who decide to use it. You can use it too, but we suggest you first think carefully about whether this license or the ordinary General Public License is the better strategy to use in any particular case, based on the explanations below.

When we speak of free software, we are referring to freedom of use, not price. Our General Public Licenses are designed to make sure that you have the freedom to distribute copies of free software (and charge for this service if you wish); that you receive source code or can get it if you want it; that you can change the software and use pieces of it in new free programs; and that you are informed that you can do these things.

To protect your rights, we need to make restrictions that forbid distributors to deny you these rights or to ask you to surrender these rights. These restrictions translate to certain responsibilities for you if you distribute copies of the library or if you modify it.

For example, if you distribute copies of the library, whether gratis or for a fee, you must give the recipients all the rights that we gave you. You must make sure that they, too, receive or can get the source code. If you link other code with the library, you must provide complete object files to the recipients, so that they can relink them with the library after making changes to the library and recompiling it. And you must show them these terms so they know their rights.

We protect your rights with a two-step method: (1) we copyright the library, and (2) we offer you this license, which gives you legal permission to copy, distribute and/or modify the library.

To protect each distributor, we want to make it very clear that there is no warranty for the free library. Also, if the library is modified by someone else and passed on, the recipients should know that what they have is not the original version, so that the original author's reputation will not be affected by problems that might be introduced by others.

Finally, software patents pose a constant threat to the existence of any free program. We wish to make sure that a company cannot effectively restrict the users of a free program by obtaining a restrictive license from a patent holder.

Therefore, we insist that any patent license obtained for a version of the library must be consistent with the full freedom of use specified in this license.

Most GNU software, including some libraries, is covered by the ordinary GNU General Public License. This license, the GNU Lesser General Public License, applies to certain designated libraries, and is quite different from the ordinary General Public License. We use this license for certain libraries in order to permit linking those libraries into non-free programs.

When a program is linked with a library, whether statically or using a shared library, the combination of the two is legally speaking a combined work, a derivative of the original library. The ordinary General Public License therefore permits such linking only if the entire combination fits its criteria of freedom. The Lesser General Public License permits more lax criteria for linking other code with the library.

We call this license the "Lesser" General Public License because it does Less to protect the user's freedom than the ordinary General Public License. It also provides other free software developers Less of an advantage over competing non-free programs. These disadvantages are the reason we use the ordinary General Public License for many libraries. However, the Lesser license provides advantages in certain special circumstances.

For example, on rare occasions, there may be a special need to encourage the widest possible use of a certain library, so that it becomes a de-facto standard. To achieve this, non-free programs must be allowed to use the library. A more frequent case is that a free library does the same job as widely used non-free libraries. In this case, there is little to gain by limiting the free library to free software only, so we use the Lesser General Public License.

In other cases, permission to use a particular library in non-free programs enables a greater number of people to use a large body of free software. For example, permission to use the GNU C Library in non-free programs enables many more people to use the whole GNU operating system, as well as its variant, the GNU/Linux operating system.

APPENDIX

Although the Lesser General Public License is Less protective of the users' freedom, it does ensure that the user of a program that is linked with the Library has the freedom and the wherewithal to run that program using a modified version of the Library.

The precise terms and conditions for copying, distribution and modification follow. Pay close attention to the difference between a "work based on the library" and a "work that uses the library". The former contains code derived from the library, whereas the latter must be combined with the library in order to run.

GNU LESSER GENERAL PUBLIC LICENSE TERMS AND CONDITIONS FOR COPYING, DISTRIBUTION AND MODIFICATION

0. This License Agreement applies to any software library or other program which contains a notice placed by the copyright holder or other authorized party saying it may be distributed under the terms of this Lesser General Public License (also called "this License"). Each licensee is addressed as "you".

A "library" means a collection of software functions and/or data prepared so as to be conveniently linked with application programs (which use some of those functions and data) to form executables.

The "Library", below, refers to any such software library or work which has been distributed under these terms. A "work based on the Library" means either the Library or any derivative work under copyright law: that is to say, a work containing the Library or a portion of it, either verbatim or with modifications and/or translated straightforwardly into another language. (Hereinafter, translation is included without limitation in the term "modification".)

"Source code" for a work means the preferred form of the work for making modifications to it. For a library, complete source code means all the source code for all modules it contains, plus any associated interface definition files, plus the scripts used to control compilation and installation of the library.

Activities other than copying, distribution and modification are not covered by this License; they are outside its scope. The act of running a program using the Library is not restricted, and output from such a program is covered only if its contents constitute a work based on the Library (independent of the use of the Library in a tool for writing it). Whether that is true depends on what the Library does and what the program that uses the Library does.

1. You may copy and distribute verbatim copies of the Library's complete source code as you receive it, in any medium, provided that you conspicuously and appropriately publish on each copy an appropriate copyright notice and disclaimer of warranty; keep intact all the notices that refer to this License and to the absence of any warranty; and distribute a copy of this License along with the Library.

You may charge a fee for the physical act of transferring a copy, and you may at your option offer warranty protection in exchange for a fee.

2. You may modify your copy or copies of the Library or any portion of it, thus forming a work based on the Library, and copy and distribute such modifications or work under the terms of Section 1 above, provided that you also meet all of these conditions:

- a) The modified work must itself be a software library.
- b) You must cause the files modified to carry prominent notices stating that you changed the files and the date of any change.
- c) You must cause the whole of the work to be licensed at no charge to all third parties under the terms of this License.
- d) If a facility in the modified Library refers to a function or a table of data to be supplied by an application program that uses the facility, other than as an argument passed when the facility is invoked, then you must make a good faith effort to ensure that, in the event an application does not supply such function or table, the facility still operates, and performs whatever part of its purpose remains meaningful.

(For example, a function in a library to compute square roots has a purpose that is entirely well-defined independent of the application. Therefore, Subsection 2d requires that any application-supplied function or table used by this function must be optional: if the application does not supply it, the square root function must still compute square roots.)

These requirements apply to the modified work as a whole. If identifiable sections of that work are not derived from the Library, and can be reasonably considered independent and separate works in themselves, then this License, and its terms, do not apply to those sections when you distribute them as separate works. But when you distribute the same sections as part of a whole which is a work based on the Library, the distribution of the whole must be on the terms of this License, whose permissions for other licensees extend to the entire whole, and thus to each and every part regardless of who wrote it.

Thus, it is not the intent of this section to claim rights or contest your rights to work written entirely by you; rather, the intent is to exercise the right to control the distribution of derivative or collective works based on the Library.

In addition, mere aggregation of another work not based on the Library with the Library (or with a work based on the Library) on a volume of a storage or distribution medium does not bring the other work under the scope of this License.

3. You may opt to apply the terms of the ordinary GNU General Public License instead of this License to a given copy of the Library. To do this, you must alter all the notices that refer to this License, so that they refer to the ordinary GNU General Public License, version 2, instead of to this License. (If a newer version than version 2 of the ordinary GNU General Public License has appeared, then you can specify that version instead if you wish.) Do not make any other change in these notices. Once this change is made in a given copy, it is irreversible for that copy, so the ordinary GNU General Public License applies to all subsequent copies and derivative works made from that copy. This option is useful when you wish to copy part of the code of the Library into a program that is not a library.

4. You may copy and distribute the Library (or a portion or derivative of it, under Section 2) in object code or executable form under the terms of Sections 1 and 2 above provided that you accompany it with the complete corresponding machine-readable source code, which must be distributed under the terms of Sections 1 and 2 above on a medium customarily used for software interchange.

If distribution of object code is made by offering access to copy from a designated place, then offering equivalent access to copy the source code from the same place satisfies the requirement to distribute the source code, even though third parties are not compelled to copy the source along with the object code.

5. A program that contains no derivative of any portion of the Library, but is designed to work with the Library by being compiled or linked with it, is called a “work that uses the Library”. Such a work, in isolation, is not a derivative work of the Library, and therefore falls outside the scope of this License.

However, linking a “work that uses the Library” with the Library creates an executable that is a derivative of the Library (because it contains portions of the Library), rather than a “work that uses the library”. The executable is therefore covered by this License. Section 6 states terms for distribution of such executables.

When a “work that uses the Library” uses material from a header file that is part of the Library, the object code for the work may be a derivative work of the Library even though the source code is not. Whether this is true is especially significant if the work can be linked without the Library, or if the work is itself a library. The threshold for this to be true is not precisely defined by law.

If such an object file uses only numerical parameters, data structure layouts and accessors, and small macros and small inline functions (ten lines or less in length), then the use of the object file is unrestricted, regardless of whether it is legally a derivative work. (Executables containing this object code plus portions of the Library will still fall under Section 6.)

Otherwise, if the work is a derivative of the Library, you may distribute the object code for the work under the terms of Section 6. Any executables containing that work also fall under Section 6, whether or not they are linked directly with the Library itself.

6. As an exception to the Sections above, you may also combine or link a “work that uses the Library” with the Library to produce a work containing portions of the Library, and distribute that work under terms of your choice, provided that the terms permit modification of the work for the customer’s own use and reverse engineering for debugging such modifications.

You must give prominent notice with each copy of the work that the Library is used in it and that the Library and its use are covered by this License. You must supply a copy of this License. If the work during execution displays copyright notices, you must include the copyright notice for the Library among them, as well as a reference directing the user to the copy of this License. Also, you must do one of these things:

a) Accompany the work with the complete corresponding machine-readable source code for the Library including whatever changes were used in the work (which must be distributed under Sections 1 and 2 above); and, if the work is an executable linked with the Library, with the complete machine-readable “work that uses the Library”, as object code and/or source code, so that the user can modify the Library and then relink to produce a modified executable containing the modified Library. (It is understood that the user who changes the contents of definitions files in the Library will not necessarily be able to recompile the application to use the modified definitions.)

b) Use a suitable shared library mechanism for linking with the Library. A suitable mechanism is one that (1) uses at run time a copy of the library already present on the user’s computer system, rather than copying library functions into the executable, and (2) will operate properly with a modified version of the library, if the user installs one, as long as the modified version is interface-compatible with the version that the work was made with.

APPENDIX

c) Accompany the work with a written offer, valid for at least three years, to give the same user the materials specified in Subsection 6a, above, for a charge no more than the cost of performing this distribution.

d) If distribution of the work is made by offering access to copy from a designated place, offer equivalent access to copy the above specified materials from the same place.

e) Verify that the user has already received a copy of these materials or that you have already sent this user a copy.

For an executable, the required form of the “work that uses the Library” must include any data and utility programs needed for reproducing the executable from it. However, as a special exception, the materials to be distributed need not include anything that is normally distributed (in either source or binary form) with the major components (compiler, kernel, and so on) of the operating system on which the executable runs, unless that component itself accompanies the executable.

It may happen that this requirement contradicts the license restrictions of other proprietary libraries that do not normally accompany the operating system. Such a contradiction means you cannot use both them and the Library together in an executable that you distribute.

7. You may place library facilities that are a work based on the Library side-by-side in a single library together with other library facilities not covered by this License, and distribute such a combined library, provided that the separate distribution of the work based on the Library and of the other library facilities is otherwise permitted, and provided that you do these two things:

a) Accompany the combined library with a copy of the same work based on the Library, uncombined with any other library facilities. This must be distributed under the terms of the Sections above.

b) Give prominent notice with the combined library of the fact that part of it is a work based on the Library, and explaining where to find the accompanying uncombined form of the same work.

8. You may not copy, modify, sublicense, link with, or distribute the Library except as expressly provided under this License. Any attempt otherwise to copy, modify, sublicense, link with, or distribute the Library is void, and will automatically terminate your rights under this License. However, parties who have received copies, or rights, from you under this License will not have their licenses terminated so long as such parties remain in full compliance.

9. You are not required to accept this License, since you have not signed it. However, nothing else grants you permission to modify or distribute the Library or its derivative works. These actions are prohibited by law if you do not accept this License. Therefore, by modifying or distributing the Library (or any work based on the Library), you indicate your acceptance of this License to do so, and all its terms and conditions for copying, distributing or modifying the Library or works based on it.

10. Each time you redistribute the Library (or any work based on the Library), the recipient automatically receives a license from the original licensor to copy, distribute, link with or modify the Library subject to these terms and conditions. You may not impose any further restrictions on the recipients' exercise of the rights granted herein. You are not responsible for enforcing compliance by third parties with this License.

11. If, as a consequence of a court judgment or allegation of patent infringement or for any other reason (not limited to patent issues), conditions are imposed on you (whether by court order, agreement or otherwise) that contradict the conditions of this License, they do not excuse you from the conditions of this License. If you cannot distribute so as to satisfy simultaneously your obligations under this License and any other pertinent obligations, then as a consequence you may not distribute the Library at all. For example, if a patent license would not permit royalty-free redistribution of the Library by all those who receive copies directly or indirectly through you, then the only way you could satisfy both it and this License would be to refrain entirely from distribution of the Library.

If any portion of this section is held invalid or unenforceable under any particular circumstance, the balance of the section is intended to apply, and the section as a whole is intended to apply in other circumstances.

It is not the purpose of this section to induce you to infringe any patents or other property right claims or to contest validity of any such claims; this section has the sole purpose of protecting the integrity of the free software distribution system which is implemented by public license practices. Many people have made generous contributions to the wide range of software distributed through that system in reliance on consistent application of that system; it is up to the author/donor to decide if he or she is willing to distribute software through any other system and a licensee cannot impose that choice.

This section is intended to make thoroughly clear what is believed to be a consequence of the rest of this License.

12. If the distribution and/or use of the Library is restricted in certain countries either by patents or by copyrighted interfaces, the original copyright holder who places the Library under this License may add an explicit geographical distribution limitation excluding those countries, so that distribution is permitted only in or among countries not thus excluded. In such case, this License incorporates the limitation as if written in the body of this License.

13. The Free Software Foundation may publish revised and/or new versions of the Lesser General Public License from time to time. Such new versions will be similar in spirit to the present version, but may differ in detail to address new problems or concerns.

Each version is given a distinguishing version number. If the Library specifies a version number of this License which applies to it and “any later version”, you have the option of following the terms and conditions either of that version or of any later version published by the Free Software Foundation. If the Library does not specify a license version number, you may choose any version ever published by the Free Software Foundation.

14. If you wish to incorporate parts of the Library into other free programs whose distribution conditions are incompatible with these, write to the author to ask for permission. For software which is copyrighted by the Free Software Foundation, write to the Free Software Foundation; we sometimes make exceptions for this. Our decision will be guided by the two goals of preserving the free status of all derivatives of our free software and of promoting the sharing and reuse of software generally.

NO WARRANTY

15. BECAUSE THE LIBRARY IS LICENSED FREE OF CHARGE, THERE IS NO WARRANTY FOR THE LIBRARY, TO THE EXTENT PERMITTED BY APPLICABLE LAW. EXCEPT WHEN OTHERWISE STATED IN WRITING THE COPYRIGHT HOLDERS AND/OR OTHER PARTIES PROVIDE THE LIBRARY “AS IS” WITHOUT WARRANTY OF ANY KIND, EITHER EXPRESSED OR IMPLIED, INCLUDING, BUT NOT LIMITED TO, THE IMPLIED WARRANTIES OF MERCHANTABILITY AND FITNESS FOR A PARTICULAR PURPOSE. THE ENTIRE RISK AS TO THE QUALITY AND PERFORMANCE OF THE LIBRARY IS WITH YOU. SHOULD THE LIBRARY PROVE DEFECTIVE, YOU ASSUME THE COST OF ALL NECESSARY SERVICING, REPAIR OR CORRECTION.

16. IN NO EVENT UNLESS REQUIRED BY APPLICABLE LAW OR AGREED TO IN WRITING WILL ANY COPYRIGHT HOLDER, OR ANY OTHER PARTY WHO MAY MODIFY AND/OR REDISTRIBUTE THE LIBRARY AS PERMITTED ABOVE, BE LIABLE TO YOU FOR DAMAGES, INCLUDING ANY GENERAL, SPECIAL, INCIDENTAL OR CONSEQUENTIAL DAMAGES ARISING OUT OF THE USE OR INABILITY TO USE THE LIBRARY (INCLUDING BUT NOT LIMITED TO LOSS OF DATA OR DATA BEING RENDERED INACCURATE OR LOSSES SUSTAINED BY YOU OR THIRD PARTIES OR A FAILURE OF THE LIBRARY TO OPERATE WITH ANY OTHER SOFTWARE), EVEN IF SUCH HOLDER OR OTHER PARTY HAS BEEN ADVISED OF THE POSSIBILITY OF SUCH DAMAGES.

END OF TERMS AND CONDITIONS

How to Apply These Terms to Your New Libraries

If you develop a new library, and you want it to be of the greatest possible use to the public, we recommend making it free software that everyone can redistribute and change. You can do so by permitting redistribution under these terms (or, alternatively, under the terms of the ordinary General Public License).

To apply these terms, attach the following notices to the library. It is safest to attach them to the start of each source file to most effectively convey the exclusion of warranty; and each file should have at least the “copyright” line and a pointer to where the full notice is found.

```
<one line to give the library's name and a brief idea of what it does.>  
Copyright (C) <year> <name of author>
```

This library is free software; you can redistribute it and/or modify it under the terms of the GNU Lesser General Public License as published by the Free Software Foundation; either version 2.1 of the License, or (at your option) any later version.

This library is distributed in the hope that it will be useful, but WITHOUT ANY WARRANTY; without even the implied warranty of MERCHANTABILITY or FITNESS FOR A PARTICULAR PURPOSE. See the GNU Lesser General Public License for more details.

You should have received a copy of the GNU Lesser General Public License along with this library; if not, write to the Free Software Foundation, Inc., 51 Franklin Street, Fifth Floor, Boston, MA 02110-1301 USA

Also add information on how to contact you by electronic and paper mail.

You should also get your employer (if you work as a programmer) or your school, if any, to sign a “copyright disclaimer” for the library, if necessary. Here is a sample; alter the names:

```
Yoyodyne, Inc., hereby disclaims all copyright interest in the library `Frob' (a library for tweaking knobs) written by  
James Random Hacker.
```

```
<signature of Ty Coon>, 1 April 1990  
Ty Coon, President of Vice
```

LG Electronics Inc.