



website <http://www.lgservice.com>

LG

ENGLISH

LG

Room Air Conditioner

INSTALLATION MANUAL

IMPORTANT

- Please read this instruction manual completely before installing the product.
- When the power cord is damaged, replacement should be performed by authorized personnel only.
- Installation work must be performed in accordance with the national wiring standards by authorized personnel only.
- Please retain this installation manual for future reference after reading it thoroughly.

INSTALLATION OVERVIEW

Installation Requirements

The following should be always observed for safety.....3

Installation of indoor, outdoor unit.....5

Flaring work and connection of piping7

Connection of piping(Indoor).....8

For right rear piping

For left rear piping

Connection of piping(Outdoor)11

Connecting the cable between indoor unit and outdoor unit12

Checking the drainage and Forming the piping14

Air purging15

Test running17

Required Parts

- Installation plate
- Four type "A" screws
- Connecting cable

- Pipes: Gas side3/8", 1/2", 5/8", 3/4"
Liquid side1/4", 3/8"
(Refer to page 4)

- Insulation materials
- Additional drain pipe
(Outer Diameter.....15.5mm)

Required Tools

- Level gauge
- Screw driver
- Electric drill
- Hole core drill(ø70mm)

- Flaring tool set
- Specified torque wrenches
1.8kg·m, 4.2kg·m, 5.5kg·m, 6.6kg·m
(different depending on model No.)
(Refer to page 10)
- Spanner.....Half union

- A glass of water
- Screw driver

- Hexagonal wrench(4mm)
- Gas-leak detector
- Vacuum pump
- Gauge manifold

- Owner's manual
- Thermometer
- Holder Remote Control

INSTALLATION INSTRUCTIONS

SINGLE SPLIT WALL MOUNTED AIR CONDITIONER

- Please read this instruction sheet completely before installing the product.
- When the power cord is damaged, replacement work shall be performed by authorized personnel only.
- Installation work must be performed in accordance with the national wiring standards by authorized personnel only.

Installation Parts Provided

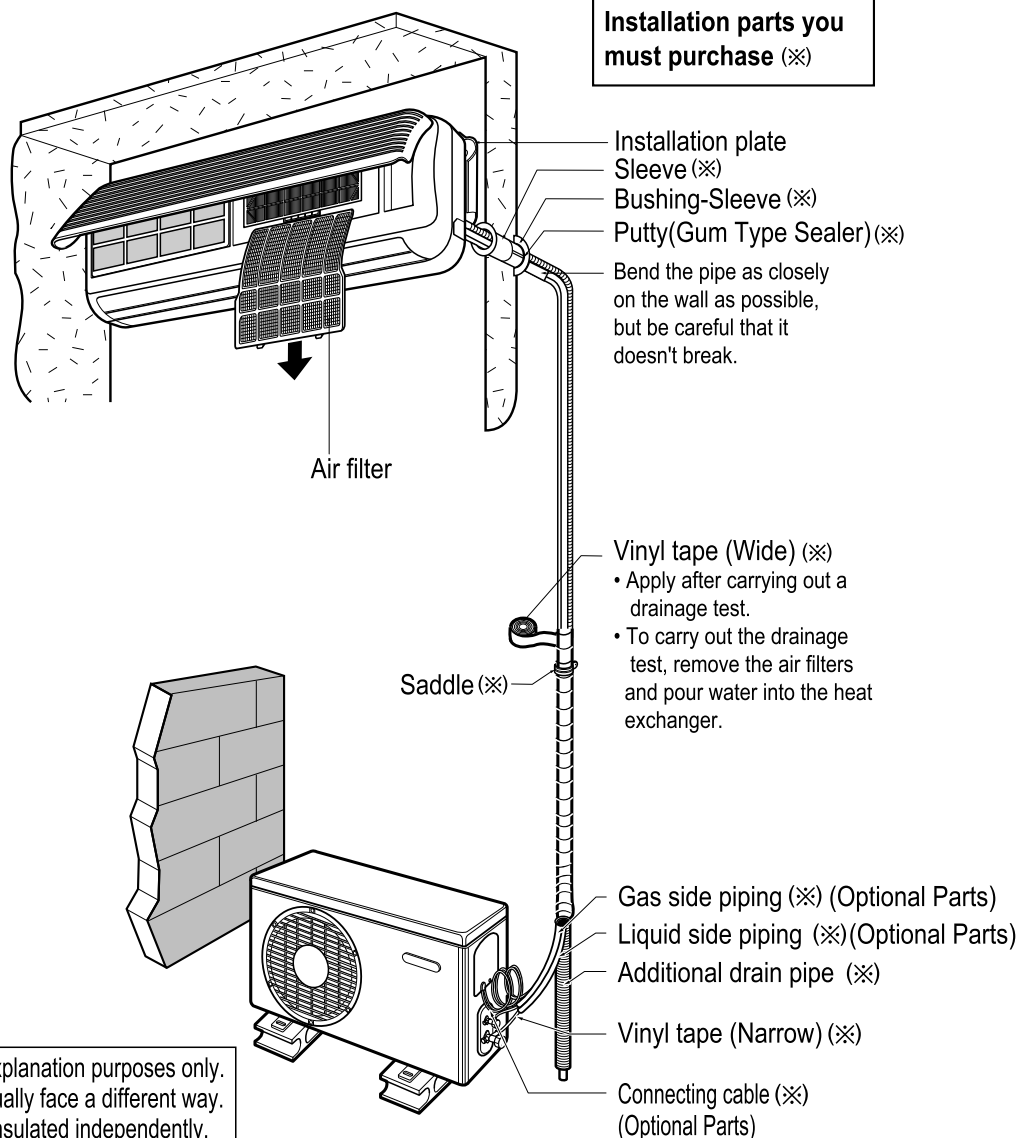
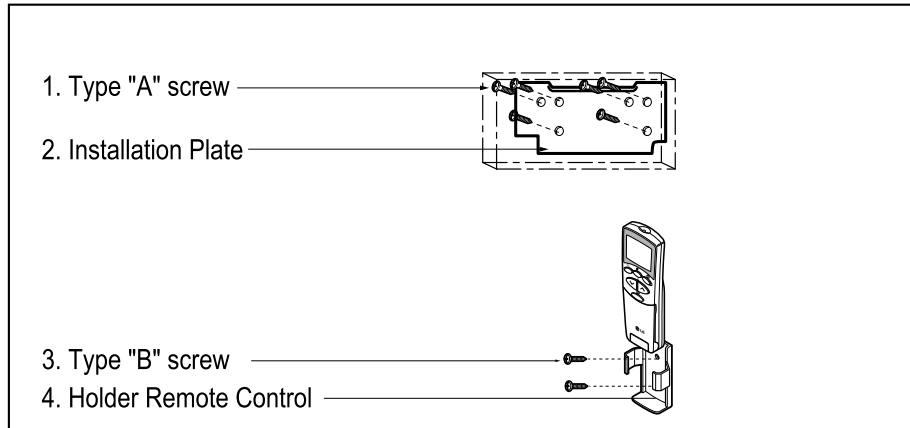

- This illustration is for explanation purposes only.
- The indoor unit will actually face a different way.
- Copper lines must be insulated independently.

THE FOLLOWING SHOULD BE ALWAYS OBSERVED FOR SAFETY

- Be sure to read "THE FOLLOWING SHOULD BE ALWAYS OBSERVED FOR SAFETY" before installing the air conditioner.
- Be sure to observe the cautions specified here as they include important items related to safety.
- The indications and meanings are as follows.



WARNING

: Could lead to death, serious injury, etc.



CAUTION

: Could lead to serious injury in particular environments when operated incorrectly.

- After reading this instructions, be sure to keep it together with the owner's manual in a handy place on the customer's site.



WARNING

Do not install it yourself (customer).

Incorrect installation could cause injury due to fire, electric shock, the unit falling or leakage of water. Consult the dealer from whom you purchased the unit or special installer.

Install the unit securely in a place which can bear the weight of the unit's.

When installed in an insufficiently strong place, the unit could fall causing injury.

Use the specified wires to connect the indoor and outdoor units securely and attach the wires firmly to the terminal board connecting sections so the stress of the wires is not applied to the sections.

Incorrect connection and attachment could cause fire.

Attach the electrical part cover to the indoor unit and the service panel to the outdoor unit securely.

If the electrical part covers of the indoor unit and/or the service panel of the outdoor unit are not attached securely, it could result in a fire or electric shock due to dust, water, etc.

Perform the installation securely referring to the installation instruction.

Incorrect installation could cause a personal injury due to fire, electric shock, the unit falling or leakage of water.

Perform electrical work according to the installation manual and be sure to use a dedicated circuit.

If the capacity of the power circuit is insufficient or there is incomplete electrical work, it could result in a fire or an electric shock.

Check that the refrigerant gas does not leak after installation is completed.

Be sure to use the part provided or specified parts for the installation work.

The use of defective parts could cause an injury due to a fire, electric shock, the unit's falling, etc.



CAUTION

Do not install the unit in a place where a flammable gas leaks.

If gas leaks and accumulates in the area surrounding the unit, it could cause an explosion.

Perform the drainage/piping work according to the installation instruction.

If there is a defect in the drainage/piping work, water could leak from the unit and household goods could come wet and be damaged.

INSTALLATION OF INDOOR, OUTDOOR UNIT

Read completely, then follow step by step.



Select the best location

A Indoor unit

- Do not have any heat or steam near the unit.
- Select a place where there are no obstacles in front of the unit.
- Make sure that condensation drainage can be conveniently routed away. Do not install near a doorway.
- Ensure that the space around the left and right of the unit is more than "A". The unit should be installed as high on the wall as possible, allowing a minimum of "B" from ceiling.
- Use a stud finder to locate studs to prevent unnecessary damage to the wall.

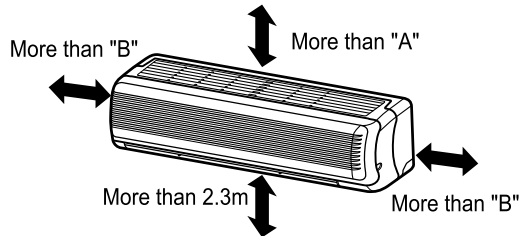

CAUTION

Install the indoor unit on the wall where the height from the floors more than 2.3 meters.

Grade	Clearance(cm)	
	A	B
5K~24K	15	15

B Outdoor unit

- If an awning is built over the unit to prevent direct sunlight or rain exposure, make sure that heat radiation from the condenser is not restricted.
- Ensure that the space around the back and sides is more than 10cm. The front of the unit should have more than 70cm of space.
- Do not place animals and plants in the path of the warm air.
- Take the air conditioner weight into account and select a place where noise and vibration are minimum.
- Select a place so that the warm air and noise from the air conditioner do not disturb neighbors.

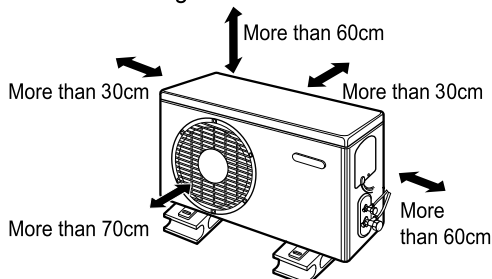

C Rooftop Installations:

- If the outdoor unit is installed on a roof structure, be sure to level the unit. Ensure the roof structure and anchoring method are adequate for the unit location.
- Consult local codes regarding rooftop mounting.

2

Piping length and elevation

Capacity (Btu/h)	Pipe Size		Standard Length (m)	Max. Elevation B (m)	Max. Length A (m)	Additional Refrigerant (g/m)
	GAS	LIQUID				
5k~12k	3/8"(Ø9.52)	1/4"(Ø6.35)	5	7	15	20
	1/2"(Ø12.7)	1/4"(Ø6.35)	5	7	15	20
18k~24k	1/2"(Ø12.7)	1/4"(Ø6.35)	5	15	30	20
	5/8"(Ø15.88)	1/4"(Ø6.35)	5	15 <td 30	20	
	5/8"(Ø15.88)	3/8"(Ø9.52)	5	15	30	30

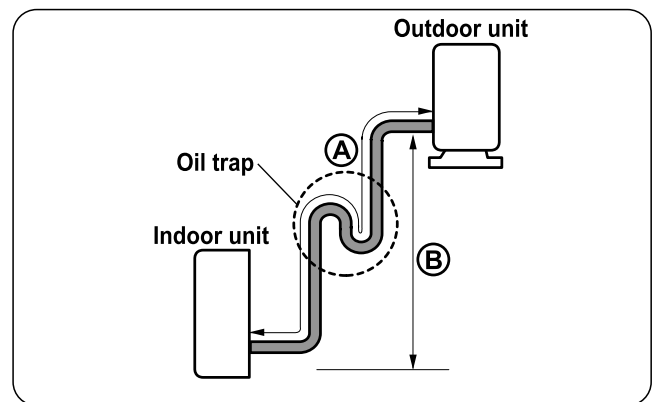
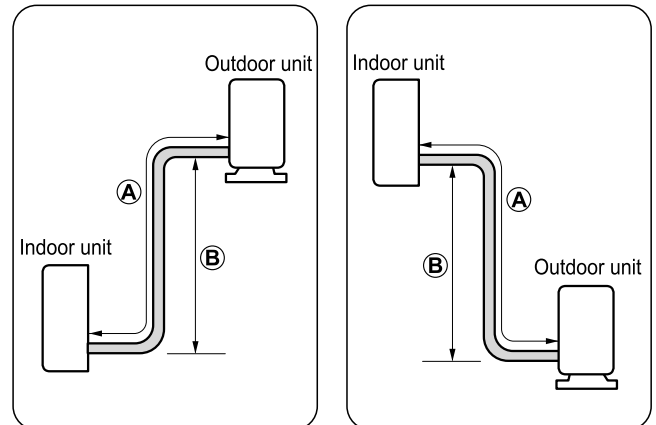

If case more than 5m

CAUTION

- Capacity is based on standard length and maximum allowance length is on the basis of reliability.
- Oil trap should be installed every 5~7 meters.

3

How to fix installation plate

The wall you select should be strong and solid enough to prevent vibration

A Mount the installation plate on the wall with 6 type "A" screws. If mounting the unit on a concrete wall, use anchor bolts.

- Mount the installation plate horizontally by aligning the centerline using a level.

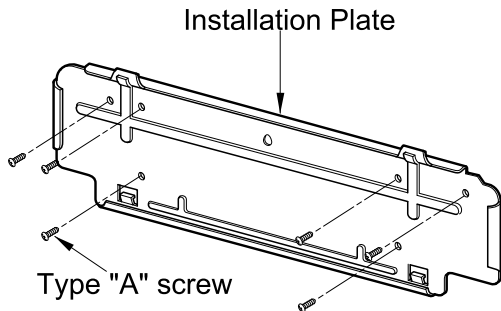

B Measure the wall and mark the centerline. It is also important to use caution concerning the location of the installation plate—routing of the wiring to power outlets is through the walls typically. Drilling the hole through the wall for piping connections must be done safely.

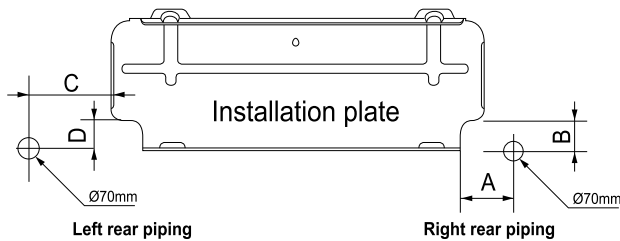

CHASSIS (Grade)	Distance (mm)			
	A	B	C	D
SQ	75	12	80	12
SR	0	40	20	40

4

Drill a hole in the wall

- Drill the piping hole with a $\varnothing 70\text{mm}$ hole core drill. Drill the piping hole at either the right or the left with the hole slightly slanted to the outdoor side.

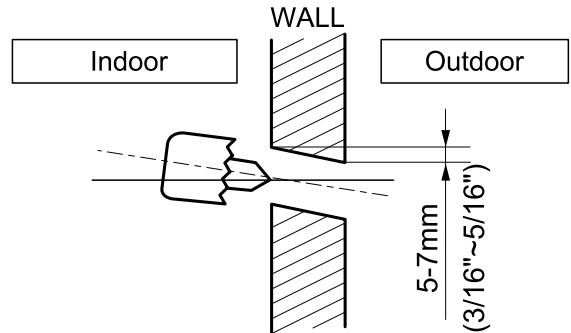

5

Installation instructions of telephone control (Optional)

- Open the Front Grille.
- Pass Telephone Control Cord Wire through the hole which the power cord goes through.
- Connect Telephone Control Cord Wire to the phone jack of telephone PCB of Control Box.
- Fix Telephone Control Cord Wire inside Control box so as not to disconnect.
- Close the Front Grille.

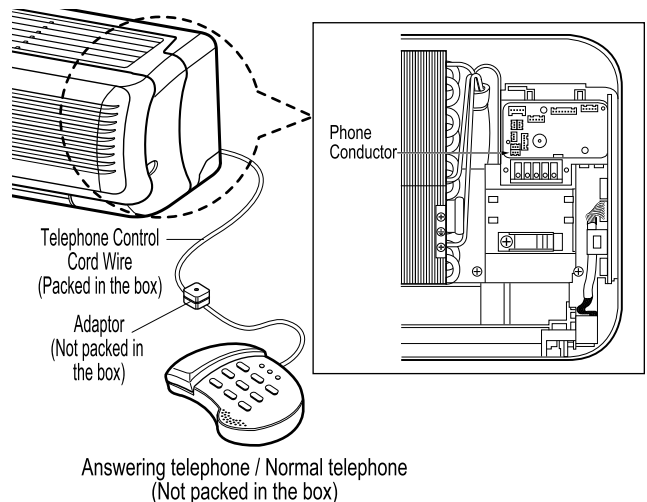

FLARING WORK AND CONNECTION OF PIPING



Flaring work

Main cause for refrigerant leakage is due to defect in the flaring work. Carry out correct flaring work using the following procedure.

A Cut the pipes and the cable.

- Use the piping kit accessory or pipes purchased locally.
- Measure the distance between the indoor and the outdoor unit.
- Cut the pipes a little longer than the measured distance.
- Cut the cable 1.5m longer than the pipe length.

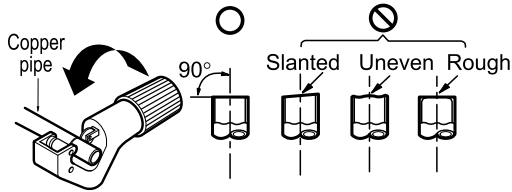

B Burr removal

- Completely remove all burrs from the cut cross section of pipe/tube.
- Put the end of the copper tube/pipe in a downward direction as you remove burrs in order to avoid dropping burrs into the tubing.

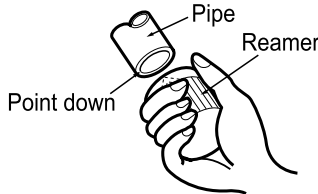

C Putting nut on

- Remove flare nuts attached to indoor and outdoor unit, then put them on pipe/tube having completed burr removal. (not possible to put them on after flaring work)

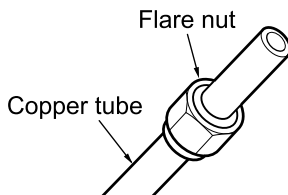

D Flaring work

- Firmly hold copper pipe in a die in the dimension shown in the table above.

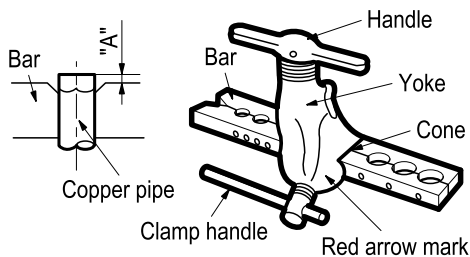

- Carry out flaring work using flaring tool as shown below.

Outside diameter		A
mm	inch	mm
Ø6.35	1/4	0~0.5
Ø9.52	3/8	0~0.5
Ø12.7	1/2	0~0.5
Ø15.88	5/8	0~1.0

E Check

- Compare the flared work with figure below.
- If flare is noted to be defective, cut off the flared section and re-flare it.

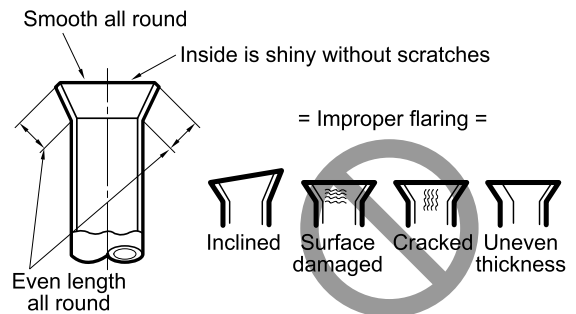

2

Connection of piping -- Indoor

- Preparing the indoor unit's piping and drain hose for installation through the wall.
- Remove the plastic tubing retainer (see illustration below) and pull the tubing and drain hose away from chassis.
- Replace the plastic tubing holder in the original position. (Optional)

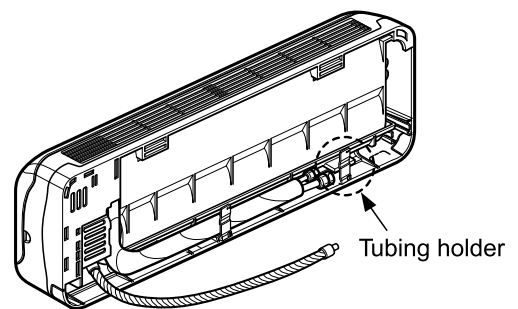

CAUTION

When install, make sure that the remaining parts must be removed clearly so as not to damage the piping and drain hose, especially power cord and connecting cable.

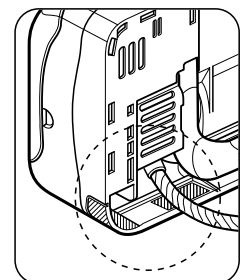

For right rear piping

- A** Route the indoor tubing and the drain hose in the direction of rear right.

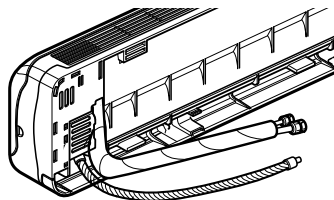

Drain hose

- B** Insert the connecting cable into the indoor unit from the outdoor unit through the piping hole.

- Do not connect the cable to the indoor unit.
- Make a small loop with the cable for easy connection later.

- C** Tape the tubing, drain hose, and the connecting cable. Be sure that the drain hose is located at the lowest side of the bundle. Locating at the upper side can cause drain pan to overflow inside the unit.

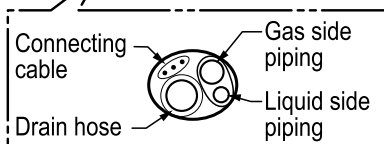
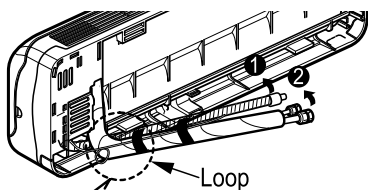

NOTE: If the drain hose is routed inside the room, insulate the hose with an insulation material* so that dripping from "sweating"(condensation) will not damage furniture or floors.

*Foamed polyethylene or equivalent is recommended.

- D** Indoor unit installation

- Hook the indoor unit onto the upper portion of the installation plate. (Engage the two hooks of the rear top of the indoor unit with the upper edge of the installation plate.) Ensure that the hooks are properly seated on the installation plate by moving it left and right.

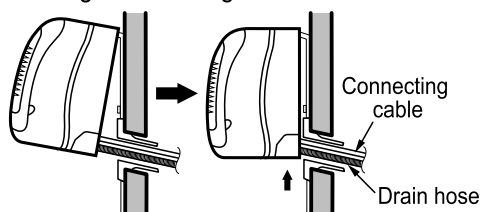

Press the lower left and right sides of the unit against the installation plate until the hooks engage into their slots (clicking sound).

- E** Connecting the pipings to the indoor unit and drain hose to drain pipe.

- Align the center of the pipes and sufficiently tighten the flare nut by hand.

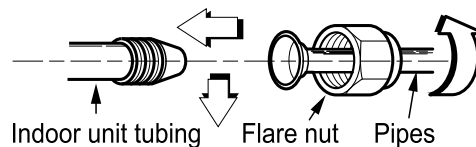

- Tighten the flare nut with a wrench.

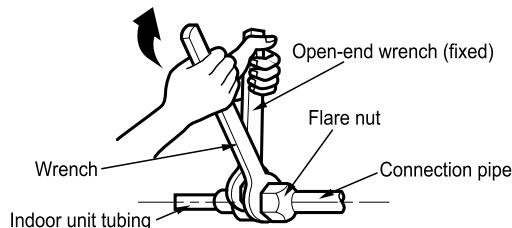

Outside diameter		Torque
mm	inch	kg-m
Ø6.35	1/4	1.8
Ø9.52	3/8	4.2
Ø12.7	1/2	5.5
Ø15.88	5/8	6.6

- When extending the drain hose at the indoor unit, install the drain pipe.

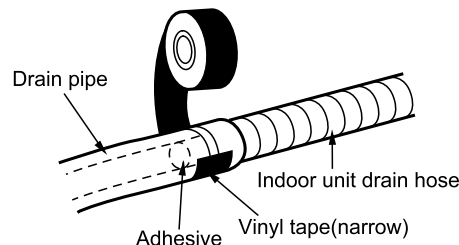

- F** Wrap the insulation material around the connecting portion.

- Overlap the connection pipe insulation material and the indoor unit pipe insulation material. Bind them together with vinyl tape so that there is no gap.

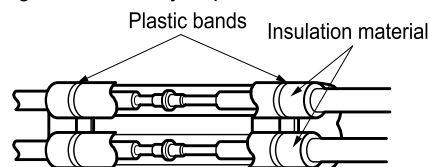

- Wrap the area which accommodates the rear piping housing section with vinyl tape.

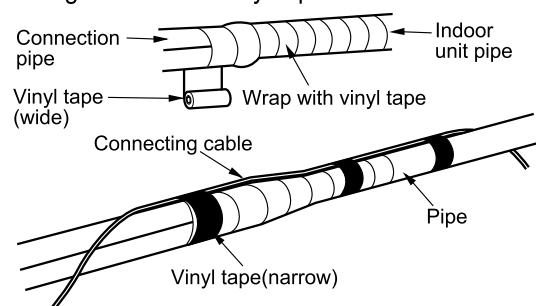

- Bundle the piping and drain hose together by wrapping them with vinyl tape for enough to cover where they fit into the rear piping housing section.

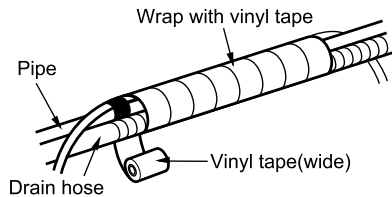

For left rear piping

- A** Route the indoor tubing and the drain hose to the required piping hole position.

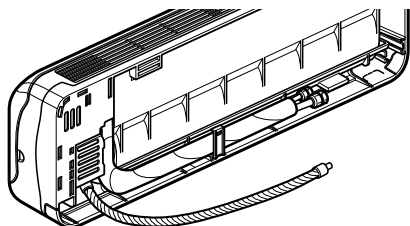

- B** Insert the piping, drain hose, and the connecting cable into the piping hole.

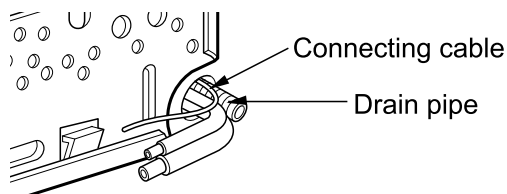

- C** Insert the connecting cable into the indoor unit.
- Don't connect the cable to the indoor unit.
 - Make a small loop with the cable for easy connection later.

- D** Tape the drain hose and the connecting cable.
- Connecting cable

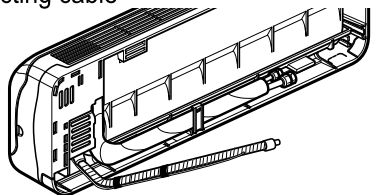

E Indoor unit installation

- Hang the indoor unit from the hooks at the top of the installation plate.
- Insert the spacer etc. between the indoor unit and the installation plate and separate the bottom of the indoor unit from the wall.

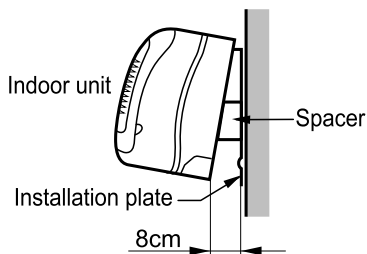

F Connecting the pipings to the indoor unit and the drain hose to drain pipe.

- Align the center of the pipes and sufficiently tighten the flare nut by hand.

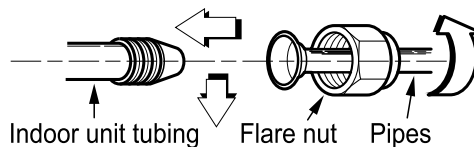

- Tighten the flare nut with a wrench.

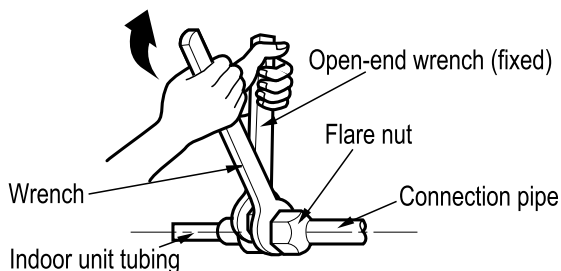

Outside diameter		Torque
mm	inch	kg-m
Ø6.35	1/4	1.8
Ø9.52	3/8	4.2
Ø12.7	1/2	5.5
Ø15.88	5/8	6.6

- When extending the drain hose at the indoor unit, install the drain pipe.

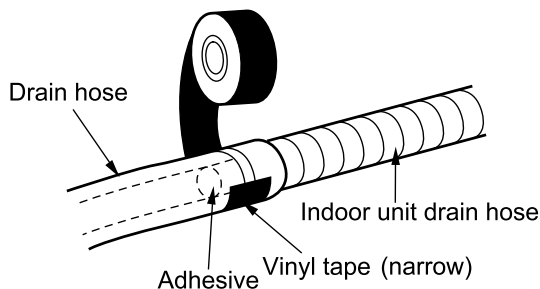

G Wrap the insulation material around the connecting portion.

- Overlap the connection pipe heat insulation and the indoor unit pipe heat insulation material. Bind them together with vinyl tape so that there is no gap.

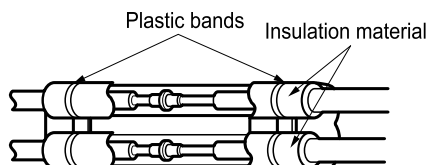

- Wrap the area which accommodates the rear piping housing section with vinyl tape.

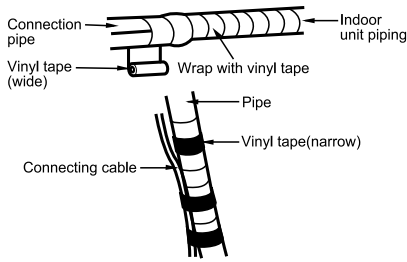

- Bundle the piping and drain hose together by wrapping them with cloth tape over the range within which they fit into the rear piping housing

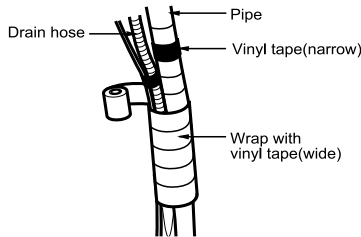

- H** Reroute the pipings and the drain hose across the back of the chassis.

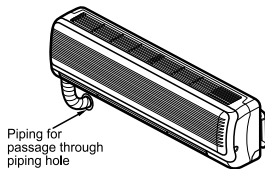

- I** Set the pipings and the drain hose to the back of the chassis with the tubing holder.
 - Hook the edge of tubing holder to tap on chassis and push the bottom of tubing holder to be engaged at the bottom of chassis.

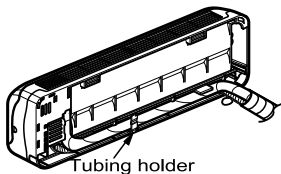

3 Connection of the pipes-Outdoor

- A** Align the center of the pipings and sufficiently tighten the flare nut by hand.

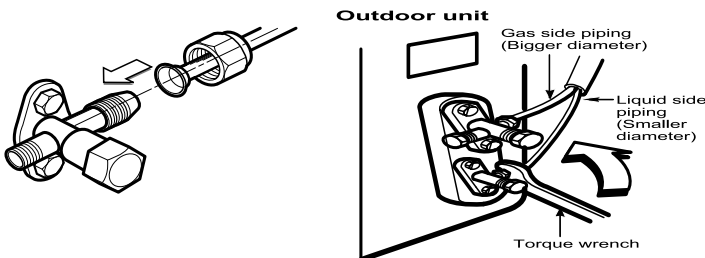

- B** Finally, tighten the flare nut with torque wrench until the wrench clicks.

- When tightening the flare nut with torque wrench, ensure the direction for tightening follows the arrow on the wrench.

Outside diameter		Torque kg-m
mm	inch	
Ø6.35	1/4	1.8
Ø9.52	3/8	4.2
Ø12.7	1/2	5.5
Ø15.88	5/8	6.6

J Indoor unit installation

- Remove the spacer.
- Ensure that the hooks are properly seated on the installation plate by moving it left and right.

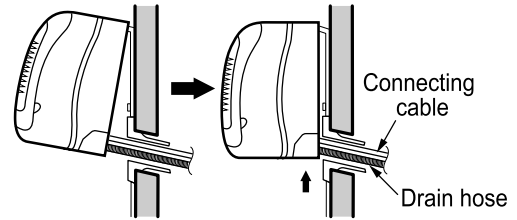

Press the lower left and right sides of the unit against the installation plate until the hooks engage into their slots (clicking sound).

⚠ CAUTION

Installation Information (For left piping)

• Good case

For left piping. Follow the instruction below.

- Press on the upper side of clamp. **(A)**

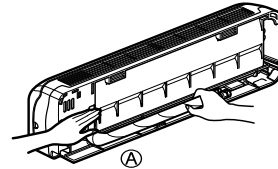

- Unfold the tubing to downward slowly. **(B)**

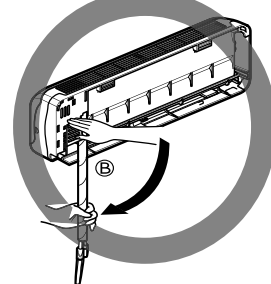

- Bend the tubing to the left side of chassis.

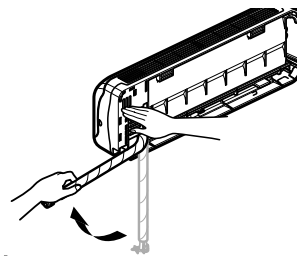

• Bad case

- Following bending type from right to left could cause problem of pipe damage.

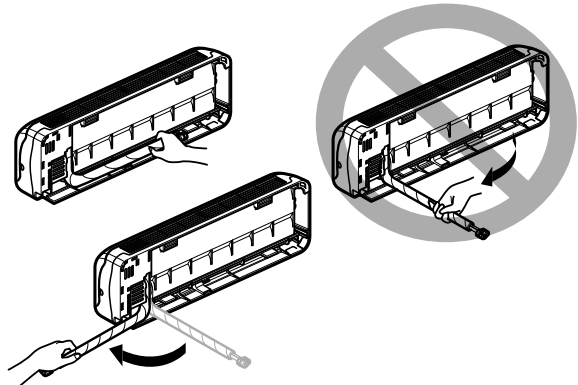

CONNECTING THE CABLE BETWEEN INDOOR UNIT AND OUTDOOR UNIT



Connect the cable to the Indoor unit.

- **Connect the cable to the indoor unit by connecting the wires to the terminals on the control board individually according to the outdoor unit connection.** (Ensure that the color of the wires of the outdoor unit and the terminal No. are the same as those of the indoor unit.)
The earth wire should be longer than the common wires.
The above circuit diagram is subject to change without notice.
When installing, refer to the circuit diagram on the control box inside Indoor Unit.

- When installing, refer to the circuit diagram on the Control Box of Indoor Unit.
- When installing, refer to the wiring diagram on the Control Cover Inside Outdoor Unit.

CAUTION

- The above circuit diagram is subject to change without notice.
- Be sure to connect wires according to the wiring diagram.
- Connect the wires firmly, so that not to be pulled out easily.
- Connect the wires according to color codes by referring the wiring diagram.

CAUTION

If a power plug is not to be used, provide a circuit breaker between power source and the unit as shown below.

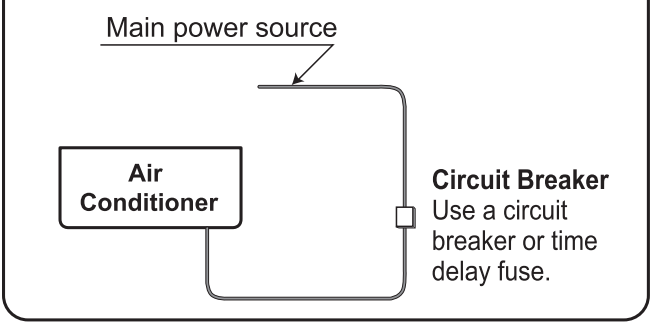

CAUTION

The power cord connected to the "A" unit should be complied with the following specifications (Type "B" approved by HAR or SAA).

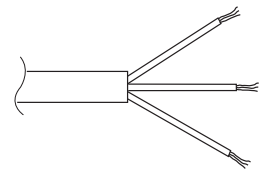

NORMAL CROSS-SECTIONAL AREA	Grade		
	5k~12k	18k	24k
	1.0	1.5	2.5
Unit(A)	Indoor	Indoor	Indoor
Cable Type(B)	H05VV-F	H05VV-F	H05VV-F

The power connecting cable connected to the indoor and outdoor unit should be complied with the following specifications (Type "B" approved by HAR or SAA).

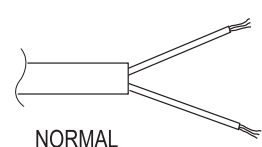
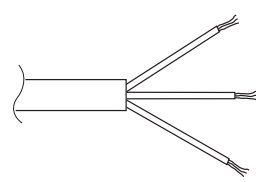

NORMAL CROSS-SECTIONAL AREA	Grade		
	5k~12k	18k	24k
	1.0	1.5	2.5
Cable Type(B)	H07RN-F	H07RN-F	H07RN-F

NORMAL CROSS-SECTIONAL AREA 0.75mm²

2

Connect the cable to the outdoor unit

- A** Remove the control cover from the unit by loosening the screw.
Connect the wires to the terminals on the control board individually.
- B** Secure the cable onto the control board with the cord clamp.
- C** Refix the control cover to the original position with the screw.
- D** Use a recognized circuit breaker "A" between the power source and the unit.
A disconnecting device to adequately disconnect all supply lines must be fitted.

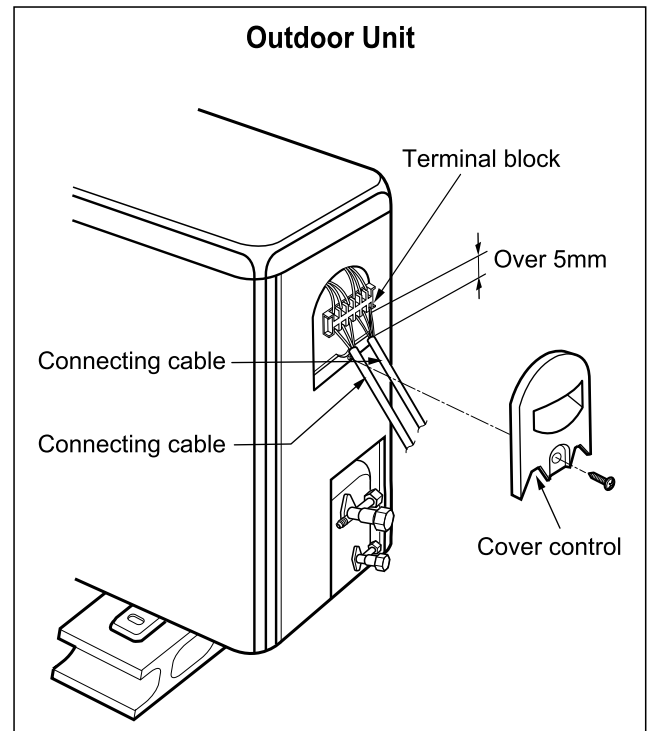

Circuit Breaker (A)	Grade		
	5k~12k	18k	24k
	15	20	30

CAUTION

After the confirmation of the above conditions, prepare the wiring as follows:

- 1) **Never fail to have an individual power circuit specifically for the air conditioner. As for the method of wiring, be guided by the circuit diagram posted on the inside of control cover.**
- 2) **The screw which fasten the wiring in the casing of electrical fittings are liable to come loose from vibrations to which the unit is subjected during the course of transportation. Check them and make sure that they are all tightly fastened. (If they are loose, it could cause burn-out of the wires.)**
- 3) **Specification of power source.**
- 4) **Confirm that electrical capacity is sufficient.**
- 5) **See to that the starting voltage is maintained at more than 90 percent of the rated voltage marked on the name plate.**
- 6) **Confirm that the cable thickness is as specified in the power source specification. (Particularly note the relation between cable length and thickness. (Refer to page 12))**
- 7) **Always install an earth leakage circuit breaker in a wet or moist area.**
- 8) **The following would be caused by voltage drop.**
 - Vibration of a magnetic switch, which will damage the contact point, fuse breaking, disturbance of the normal function of the overload.
- 9) **The means for disconnection from a power supply shall be incorporated in the fixed wiring and have an air gap contact separation of at least 3mm in each active(phase) conductors.**

CHECKING THE DRAINAGE AND FORMING THE PIPINGS



1 Checking the drainage

A To remove the front panel from the indoor unit.

- Set the air direction louvers up-and-down to the position(horizontally) by hand.
- Remove the securing screws that retain the front panel. Push the lower left and right sides of the grille toward you and lift it off.

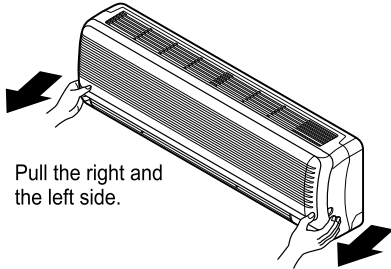

B To check the drainage.

- Pour a glass of water on the evaporator.
- Ensure the water flows through the drain hose of the indoor unit without any leakage and goes out the drain exit.

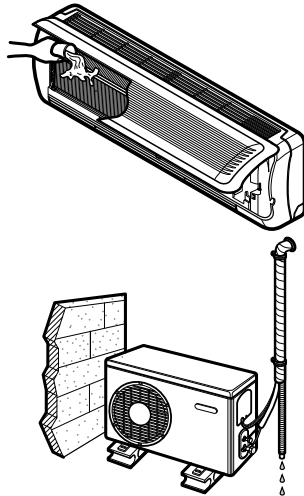

C Drain piping

- The drain hose should point downward for easy drain flow.

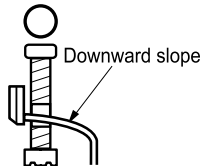

- Do not make drain piping.

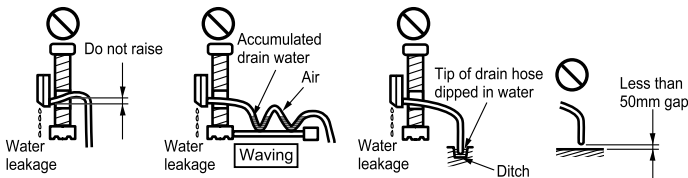

2 Form the piping

A Form the piping by wrapping the connecting portion of the indoor unit with insulation material and secure it with two kinds of vinyl tapes.

- If you want to connect an additional drain hose, the end of the drain outlet should be routed above the ground. Secure the drain hose appropriately.

B In cases where the outdoor unit is installed below the indoor unit perform the following.

- Tape the piping, drain hose and connecting cable from down to up.
- Secure the taped piping along the exterior wall using saddle or equivalent.

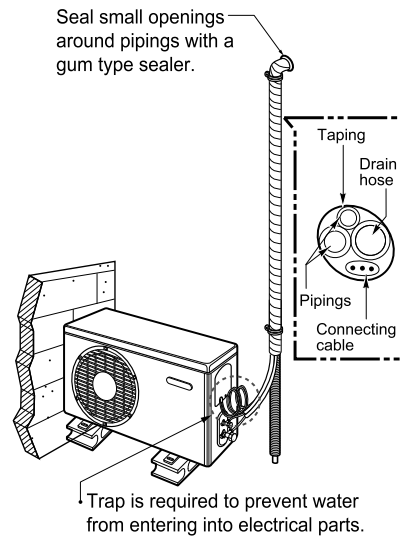

C In cases where the Outdoor unit is installed above the Indoor unit perform the following.

- Tape the piping and connecting cable from down to up.
- Secure the taped piping along the exterior wall. Form a trap to prevent water entering the room.
- Fix the piping onto the wall by saddle or equivalent.

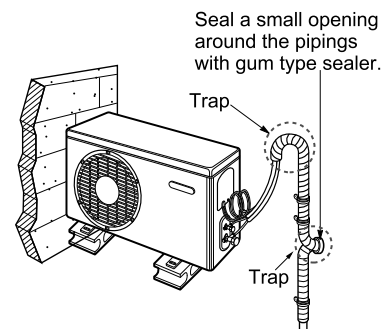

AIR PURGING



Air purging

Air and moisture remaining in the refrigerant system have undesirable effects as indicated below.

- Pressure in the system rises.
- Operating current rises.
- Cooling(or heating) efficiency drops.
- Moisture in the refrigerant circuit may freeze and block capillary tubing.
- Water may lead to corrosion of parts in the refrigeration system.

Therefore, the indoor unit and tubing between the indoor and outdoor unit must be leak tested and evacuated to remove any noncondensables and moisture from the system.

- Do a leak test of all joints of the tubing(both indoor and outdoor) and both gas and liquid side service valves. Bubbles indicate a leak. Be sure to wipe off the soap with a clean cloth.
- After the system is found to be free of leaks, relieve the nitrogen pressure by loosening the charge hose connector at the nitrogen cylinder. When the system pressure is reduced to normal, disconnect the hose from the cylinder.

2 Air purging with vacuum pump

A Preparation

- Check that each tube(both liquid and gas side tubes) between the indoor and outdoor units have been properly connected and all wiring for the test run has been completed. Remove the service valve caps from both the gas and the liquid side on the outdoor unit. Note that both the liquid and the gas side service valves on the outdoor unit are kept closed at this stage.

B Leak test

- Connect the manifold valve(with pressure gauges) and dry nitrogen gas cylinder to this service port with charge hoses.

⚠ CAUTION

Be sure to use a manifold valve for air purging. If it is not available, use a stop valve for this purpose. The "Hi" knob of the manifold valve must always be kept close.

- Pressurize the system to no more than 150 P.S.I.G. with dry nitrogen gas and close the cylinder valve when the gauge reading reached 150 P.S.I.G. Next, test for leaks with liquid soap.

⚠ CAUTION

To avoid nitrogen entering the refrigerant system in a liquid state, the top of the cylinder must be higher than its bottom when you pressurize the system. Usually, the cylinder is used in a vertical standing position.

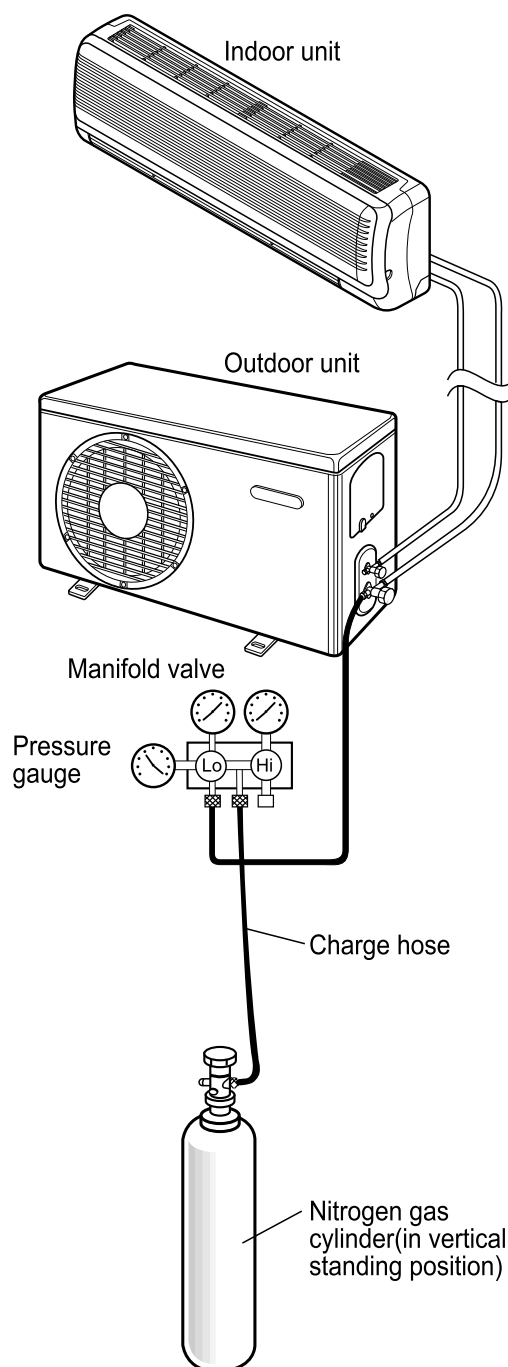

Soap water method

- (1) Remove the caps from the 2-way and 3-way valves.
- (2) Remove the service-port cap from the 3-way valve.
- (3) To open the 2-way valve turn the valve stem counterclockwise approximately 90°, wait for about 2~3 sec, and close it.
- (4) Apply a soap water or a liquid neutral detergent on the indoor unit connection or outdoor unit connections by a soft brush to check for leakage of the connecting points of the piping.
- (5) If bubbles come out, the pipes have leakage.

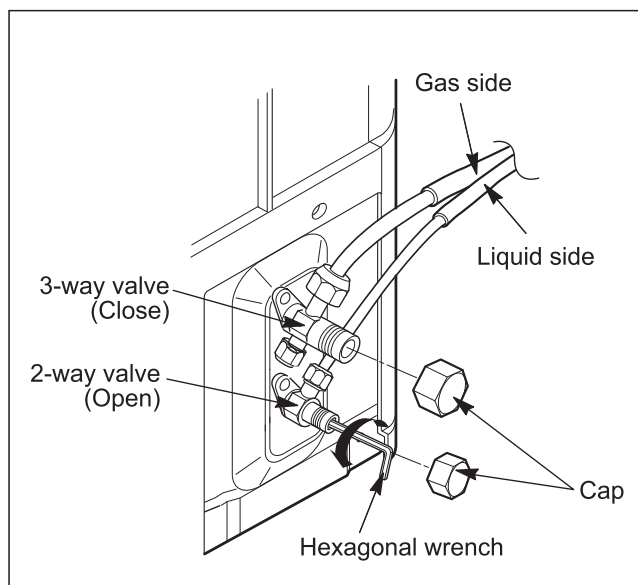

C Evacuation

- Connect the charge hose end described in the preceding steps to the vacuum pump to evacuate the tubing and indoor unit. Confirm the "Lo" knob of the manifold valve is open. Then, run the vacuum pump. The operation time for evacuation varies with tubing length and capacity of the pump. The following table shows the time required for evacuation.

Required time for evacuation when 30 gal/h vacuum pump is used	
if tubing length is less than 10m (33 ft)	if tubing length is longer than 10m (33 ft)
10 min. or more	15 min. or more

- When the desired vacuum is reached, close the "Lo" knob of the manifold valve and stop the vacuum pump.

D Finishing the job

- With a service valve wrench, turn the valve stem of liquid side valve counter-clockwise to fully open the valve.
- Turn the valve stem of gas side valve counter-clockwise to fully open the valve.
- Loosen the charge hose connected to the gas side service port slightly to release the pressure, then remove the hose.
- Replace the flare nut and its bonnet on the gas side service port and fasten the flare nut securely with an adjustable wrench. This process is very important to prevent leakage from the system.
- Replace the valve caps at both gas and liquid side service valves and fasten them tight.

This completes air purging with a vacuum pump. The air conditioner is now ready to test run.

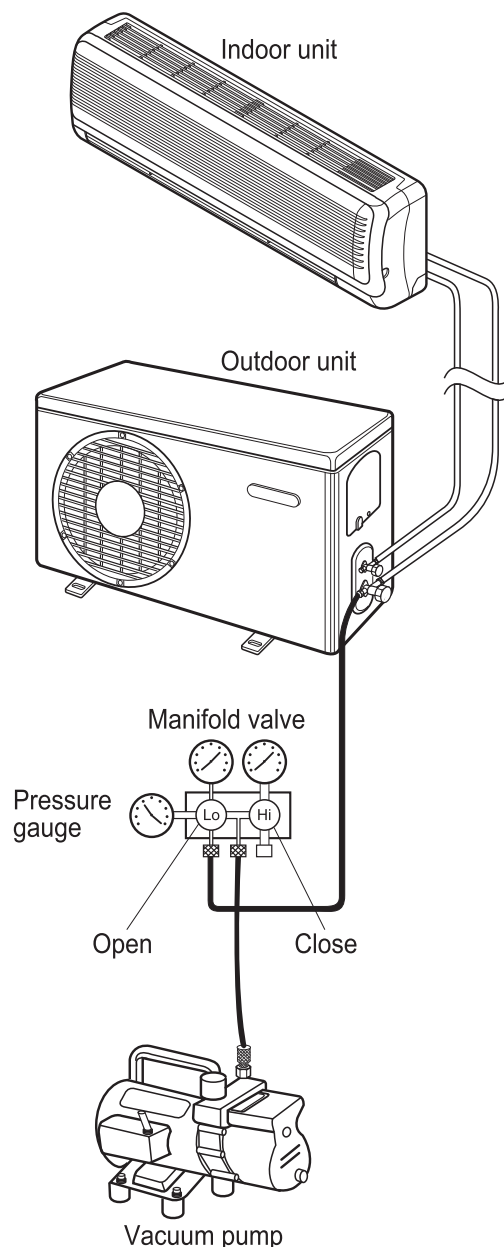

TEST RUNNING

1. Check that all tubing and wiring have been properly connected.
2. Check that the gas and liquid side service valves are fully open.

A Prepare remote control

- 1 Remove the battery cover by pulling it according to the arrow direction.
- 2 Insert new batteries making sure that the (+) and (-) of battery are installed correctly.
- 3 Reattach the cover by pushing it back into position.

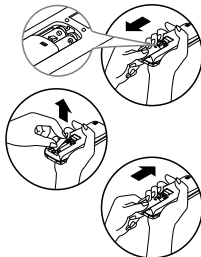

NOTE:

- Use 2 AAA(1.5volt) batteries. Do not use rechargeable batteries.
- Remove the batteries from the remote control if the system is not going to be used for a long time.

B Settlement of outdoor unit

- Anchor the outdoor unit with a bolt and nut(ø10mm) tightly and horizontally on a concrete or rigid mount.
- When installing on the wall, roof or rooftop, anchor the mounting base securely with a nail or wire assuming the influence of wind and earthquake.
- In the case when the vibration of the unit is conveyed to the hose, secure the unit with an anti-vibration bushing.

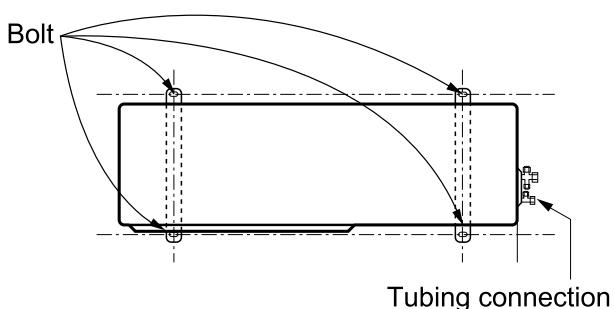

C Evaluation of the performance

Operate unit for 15~20 minutes, then check the system refrigerant charge:

1. Measure the pressure of the gas side service valve.
2. Measure the temperature of the intake and discharge of air.

3. Ensure the difference between the intake temperature and the discharge is more than 8°C(46°F) (Cooling) or (Heating).

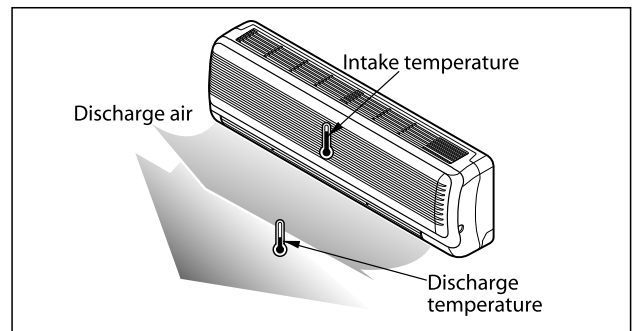

4. For reference; the gas side pressure of optimum condition is as below. (Cooling)

Refrigerant	Outside ambient TEMP.	The pressure of the gas side service valve.
R-22	35°C (95°F)	4~5kg/cm ² G(56.8~71.0 P.S.I.G.)
R-410A	35°C (95°F)	8.5~9.5kg/cm ² G(120~135 P.S.I.G.)

NOTE: If the actual pressure is higher than shown, the system is most likely over-charged, and charge should be removed. If the actual pressure are lower than shown, the system is most likely undercharged, and charge should be added. The air conditioner is now ready for use.

PUMP DOWN

This is performed when the unit is to be relocated or the refrigerant circuit is serviced. Pump Down means collecting all refrigerant in the outdoor unit without loss in refrigerant gas.

CAUTION:

Be sure to perform Pump Down procedure with the unit cooling mode.

Pump Down Procedure

1. Connect a low-pressure gauge manifold hose to the charge port on the gas side service valve.
2. Open the gas side service valve halfway and purge the air from the manifold hose using the refrigerant gas.
3. Close the liquid side service valve(all the way in).
4. Turn on the unit's operating switch and start the cooling operation.
5. When the low-pressure gauge reading becomes 1 to 0.5kg/cm²G(14.2 to 7.1 P.S.I.G.), fully close the gas side valve stem and then quickly turn off the unit. At that time, Pump Down has been completed and all refrigerant gas will have been collected in the outdoor unit.



website <http://www.lgservice.com>

LG

ENGLISH

LG

Room Air Conditioner

OWNER'S MANUAL

Prior to installation, this air-conditioning unit must be submitted for approval by the utility service which provides electricity (EN 61000-2, EN 61000-3 Norm).

IMPORTANT

- Please read this owner's manual carefully and thoroughly before installing and operating your room air conditioner.
- Please retain this owner's manual for future reference after reading it thoroughly.

Safety Precautions

Warning2
 Caution3

Operating Instructions

Preparation before operation ..4
 Remote Control Features5
 Operation Mode Selection 5
 Additional features10

Care and Maintenance

Care and Maintenance12
 Operation Tips14

Troubleshooting tips

Before You
 Call For Service15

Safety precautions

To prevent injury and property damage, follow these instructions.

 Incorrect operation due to ignoring instructions will cause harm or damage, the seriousness of which is indicated by the following symbols.

 **WARNING** _____

This symbol shows the possibility of death or serious injury.

 **CAUTION** _____

This symbol indicates the possibility of injury or damage to property.

■ The following items are classified by these symbols.

	Never Do This
	Always Do This

WARNING

 **Plug in the power plug properly.**

- Otherwise, it will cause electric shock or fire due to heat generation or electric shock.

 **Do not operate or stop the unit by inserting or pulling out the power plug.**

- It will cause electric shock or fire due to heat generation.

 **Do not damage or use an unspecified power cord.**

- It will cause electric shock or fire.
- In the supply cord is damaged, it must be replaced by the manufacturer or its service agent or a similarly qualified person in order to avoid a hazard. (Y Attachment)

 **Do not modify power cord length or share the outlet with other appliances.**

- It will cause electric shock or fire due to heat generation.

 **Do not operate with wet hands or in damp environment.**

- It may cause electric shock.

 **Do not direct airflow at room occupants only.**

- This could damage your health.

 **Always perform grounding work.**

- No grounding may cause electric shock.

 **Do not allow water to run into electric parts.**

- It may cause failure of machine or electric shock.

 **Always install air leakage breaker and a dedicated switching board.**

- No installation may cause fire and electric shock accident.

 **Unplug the unit if strange sounds, smell, or smoke comes from it.**

- It may cause fire and electric shock accident.

 **Do not use the socket if it is loose or damaged.**

- It may cause fire and electric shock.

 **Do not open the entrance during operation.**

- It may cause electric shock.

 **Keep firearms away.**

- It may cause fire.

 **Do not use the power cord close to the heating tools.**

- It may cause fire and electric shock.

 **Do not use the power cord near flammable gas or combustibles, such as gasoline, benzene, thinner, etc.**

- It may cause an explosion or fire.

WARNING

⚠ **Ventilate before operating air conditioner when gas goes out.**

• It may cause explosion, fire and, burn.

⚠ **Do not disassemble or modify products randomly.**

• It may cause failure and electric shock.

CAUTION

⚠ **Never touch the metal parts of the unit when removing the filter.**

• They are sharp and may cause injury.

⚠ **Do not clean the air conditioner with water.**

• Water may enter the unit and degrade the insulation. It may cause an electric shock.

⚠ **Ventilate well when used together with a stove, etc.**

• An oxygen shortage may occur.

⚠ **When cleaning the unit, first make sure the power and breaker are turned off.**

• Since the fan rotates at high speed during operation, it may cause injury.

⚠ **Do not put a pet or house plant where it will be exposed to direct air flow.**

• This could injure the pet or plant.

⚠ **Do not use appliance for special purpose such as animals or vegetables, precision machine, or conservation of art articles.**

• It may cause damage of animals or vegetables or loss of property.

⚠ **Stop operation and close the window in storm or hurricane.**

• Operation with windows opened may cause wetting of indoor and soaking of household furniture.

⚠ **Hold the plug by the head of the power plug when taking it out.**

• It may cause electric shock and damage.

⚠ **Turn off the main power switch when not using it for a long time.**

• It may cause failure of product or fire.

⚠ **Do not place obstacles around the absorption inlet or instead of blowing-out inlet.**

• It may cause failure of appliance or accident.

⚠ **Ensure that an installation console of the outdoor appliance is not damaged due to the use for a long time.**

• If leaving appliance damaged, there is concern of damage due to the falling of product.

⚠ **Always insert the filters securely. Clean it once every two weeks.**

• Operation without filters may cause failure.

⚠ **Do not use strong detergent such as wax or thinner but use a soft cloth.**

• Appearance may be deteriorated due to change of product color or scratching of its surface.

⚠ **Do not place heavy object on the power cord and take care so that the cord should not be pressed.**

• There is danger of fire or electric shock.

⚠ **Do not drink water drained from air conditioner.**

• It contains contaminants and will make you sick.

⚠ **Use caution when unpacking and installing. Sharp edges could cause injury.**

⚠ **If water enters the product, turn the power switch of the main body of appliance off. After taking the power-plug out from the socket, contact with the service center.**

Preparation before operation

How to Insert the Batteries

- 1 Remove the battery cover by pulling it according to the arrow direction.
- 2 Insert new batteries making sure that the (+) and (-) of battery are installed correctly.
- 3 Reattach the cover by sliding it back into position.

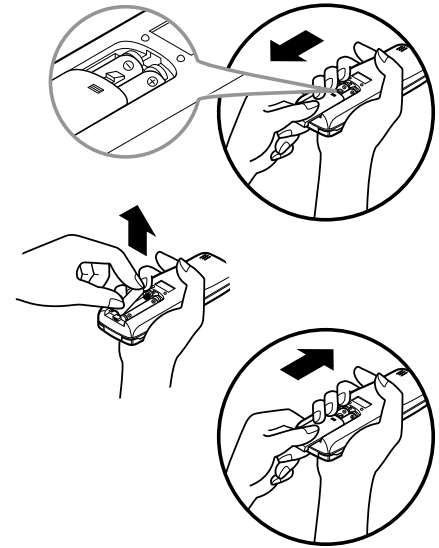

NOTES:

- Use 2 AAA(1.5volt) batteries. Do not use rechargeable batteries.

Storage and Tips For Using the Remote Control

- The remote control may be stored by mounting it on a wall.
- To operate the room air conditioner, aim the remote control at the signal receptor.

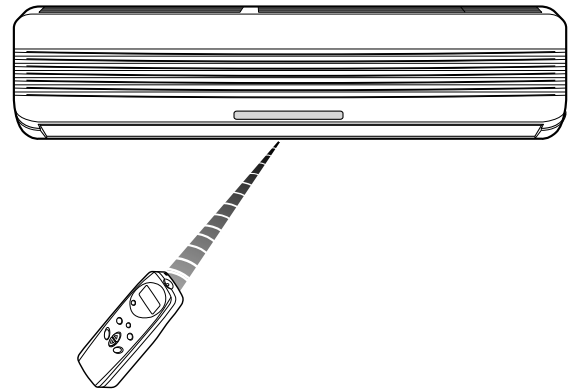
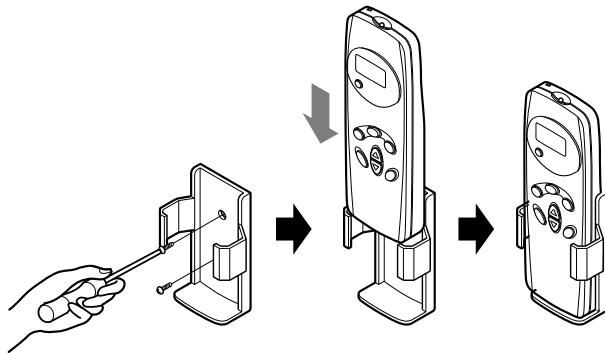

Signal Receptor

Receives the signals from the remote control.(Signal receiving sound: two short beeps or one long beep.)

Operation Indication Lamps

⊏ On/Off : Lights up during the system operation.

⌚ Timer : Lights up during Timer operation.

OUT DOOR OUTDOOR UNIT OPERATION : Lights up during outdoor unit operation. (Cooling model only)

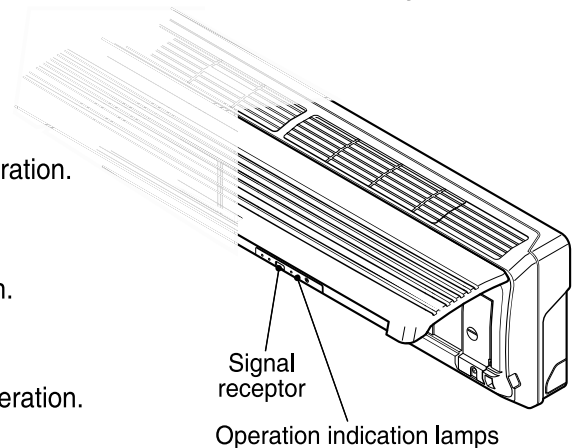

About the remote control on the system



Features of the Remote Control

Signal transmitter

Transmits the signals to the room air conditioner.

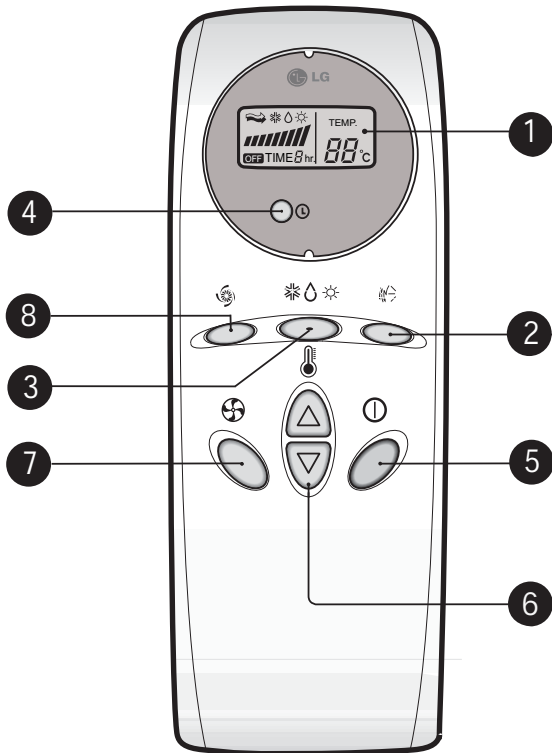

- 1** OPERATION DISPLAY
Displays the operation conditions.
- 2** AIRFLOW DIRECTION START/STOP BUTTON
Used to stop or start louver movement and set the desired up/down airflow direction.
- 3** OPERATION MODE SELECTION BUTTON
Used to select the operation mode.
- 4** OFF TIMER BUTTON
Used to set the time of stopping operation.
- 5** START/STOP BUTTON
Operation starts when this button is pressed, and stops when the button is pressed again.
- 6** ROOM TEMPERATURE SETTING BUTTONS
- 7** INDOOR FAN SPEED SELECTION BUTTON
- 8** JET COOL OPERATION BUTTON
Used to start or stop the speed (speed cooling operates super high fan speed in cooling mode.)

(1) OPERATION MODE

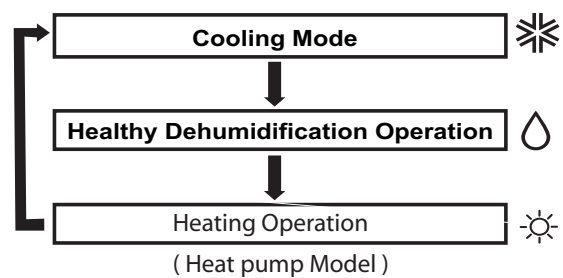
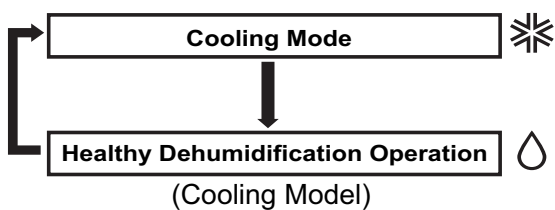

(2) OPERATION PROCEDURE

- 1st** Start/Stop Button
- 2nd** Operation Mode Selection Button
- 3rd** Room Temperature Setting Button
- 4th** Indoor Fan Speed Selection Button

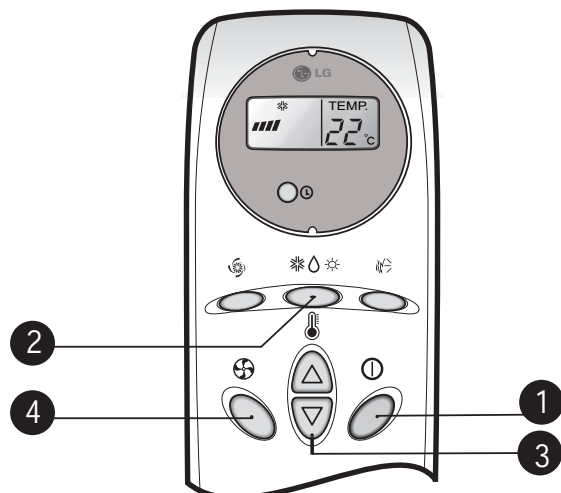

How to use the Operation Mode Selection button



Cooling Operation

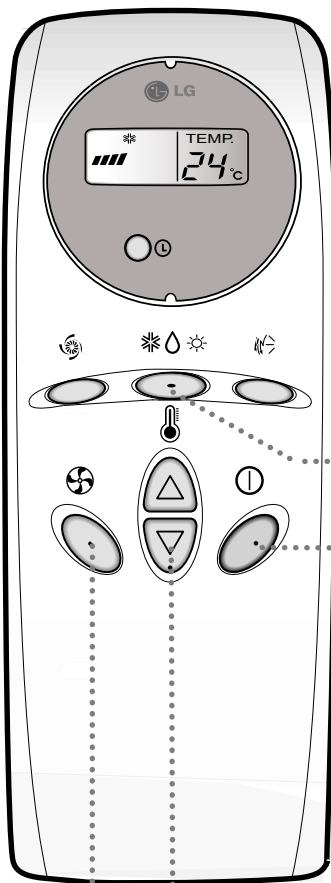

- 1** Press the Start/Stop button.
The unit will respond with a beep.

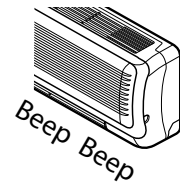

- 2** Selection Cooling Operation.
Press the Operation Mode Selection Button.
Each time the button is pressed, the operation mode is shifted in the arrow direction.

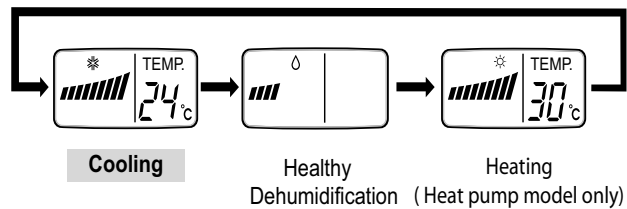

- 3** Set the temperature lower than the room temperature.
• The temperature can be set within a range of 18°C ~ 30°C by 1°C.

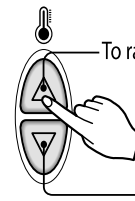

To raise the temperature

To lower the temperature

- 4** Set the fan speed.



- Select the fan speed in four steps
- Low, Medium, High and chaos.
- The display shows high fan speed

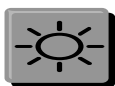

Heating Operation (Heat pump only)

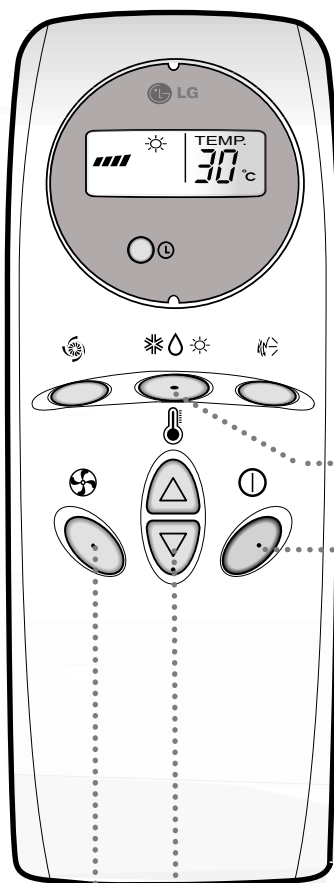

1 Press the Start/Stop button.
The unit will respond with a beep.



2 Selection Cooling Operation.
Press the Operation Mode Selection Button.
Each time the button is pressed, the operation mode is shifted in the arrow direction.

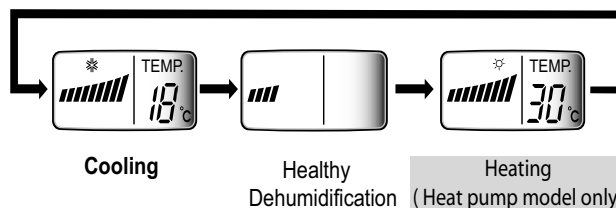

3 Set the temperature lower than the room temperature.
• The temperature can be set within a range of 16°C ~ 30°C by 1°C .

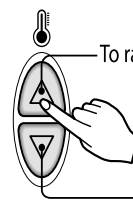

To raise the temperature

To lower the temperature

4 Set the fan speed.



- Select the fan speed in four steps
- Low , Medium High and chaos.
- The display shows high fan speed



Healthy Dehumidification Operation

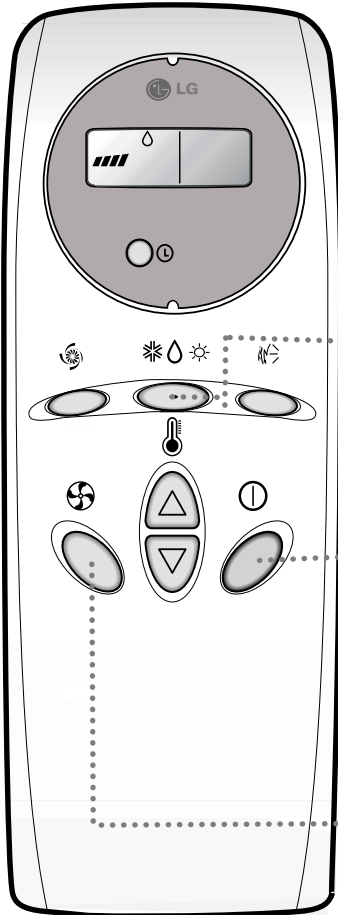

1

Press the Start/Stop button.
The unit will respond with a beep.

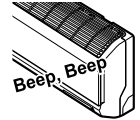

2

Select Healthy Dehumidification Operation.

Press the operation Mode Selection Button.
Each time the button is pressed, the operation mode is shifted in the arrow direction.

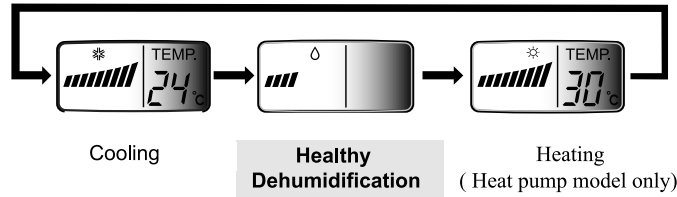

3

Set the fan speed.



- Select the fan speed in four steps - Low, Medium, High and chaos.
- The display shows high fan speed

During Healthy Dehumidification Operation:

- The indoor fan speed is automatically set to the low, so the shift of the indoor fan speed is impossible because of already being set to the best speed for Dry Operation by Micom Control.
- The indoor fan may be stopped not so as to be the room overcooling.



Jet Cool Operation

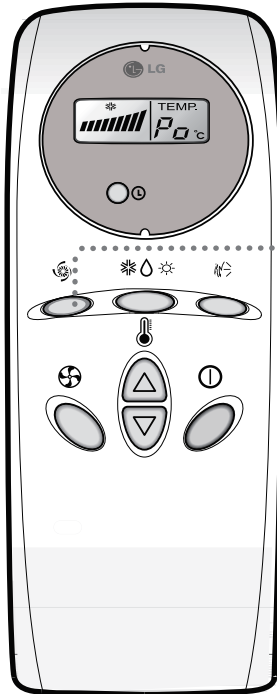

Press the **Jet Cool** button to operate the speed cooling mode and the unit will operate at super high fan speed on cooling mode for 30 minutes.



To cancel the **Jet Cool** mode, press the **Jet Cool** button, the fan speed button or the room temperature setting button again and the unit will operate at high fan speed on cooling mode.



Timer Control Setting

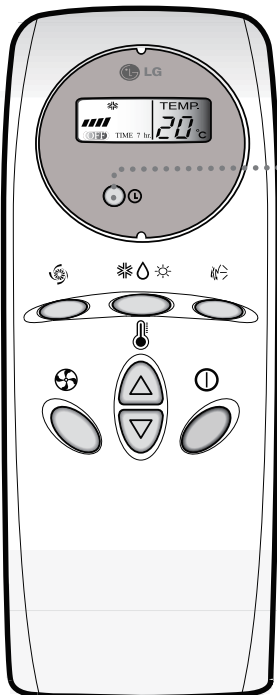

Press the OFF Time Button.

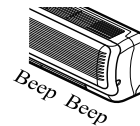

1. Press the OFF Time Button.
2. Check the OFF Time LED of the room air conditioner.
3. The Timer is programmed by 1 hour each pressing the OFF Time button from 1 hour to 7 hours.

Additional features



Vertical Airflow Direction Control

Airflow Direction Control

The airflow direction can be adjusted as desired by using the remote controller. This is effective when you want to cool yourself directly, such as after taking a bath.

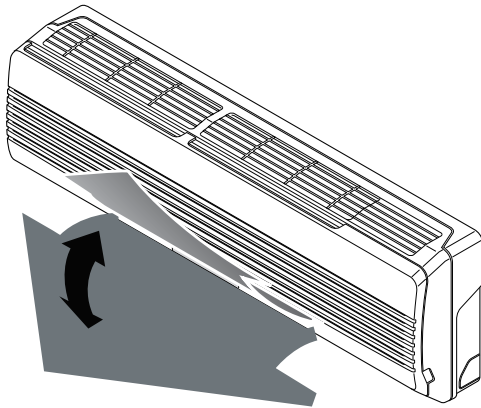

Horizontal Airflow Direction Control

- Adjust the horizontal airflow direction by manually moving the horizontal airflow direction louver by hand.

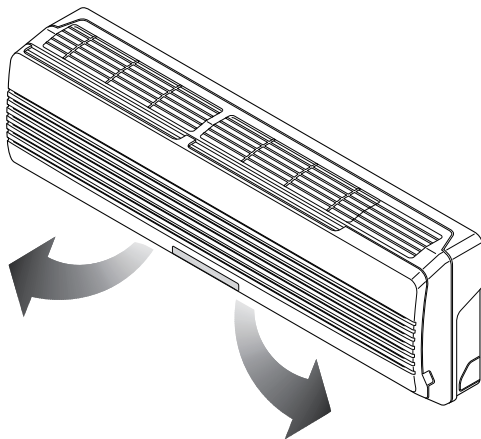

- 1 Press the Start/Stop Button.
(Confirm the unit on operation.)



- 2 Press the Airflow Direction Control Button and the vertical louvers swing up and down automatically.



- 3 Press again the Airflow Direction Control Button to set the vertical louver at the desired airflow direction.



Caution

- Always use the remote controller to adjust the airflow direction. Manually moving the vertical airflow direction louver by hand could cause operation errors.
- When air conditioner operation is stopped, the vertical airflow direction louver will close the air outlet vent of room air conditioner.



Forced Operation

Operation procedures when the remote control can't be used.
 The operation will be started if the power button is pressed.
 If you want to stop operation, re-press the button.

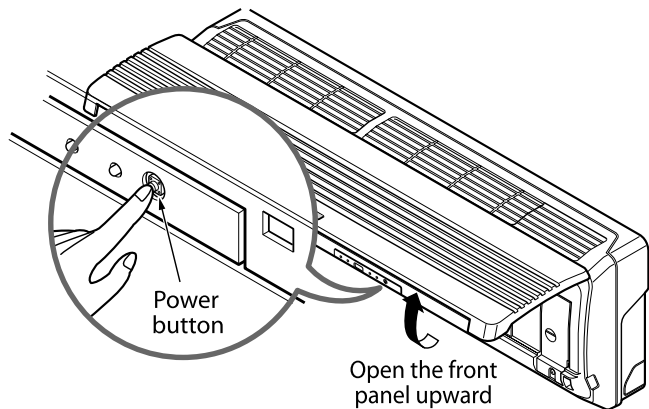

	Cooling Model	Heat pump Model		
		Room Temp. 24 °C	21 °C Room Temp. < 24 °C	Room Temp. < 21 °C
Operating mode	Cooling	Cooling	Healthy Dehumidification	Heating
Indoor FAN Speed	High	High	High	High
Setting Temperature	22 °C	22 °C	23 °C	24 °C

Test operation

During the TEST OPERATION, the unit operates in cooling mode at high speed fan, regardless of room temperature and resets in 18 minutes.

During test operation, if remote controller signal is received, the unit operates as remote controller sets.

If you want to use this operation, Press and hold the ON/OFF button for 3~5 seconds, then the buzzer sound 1 "beep".

If you want to stop the operation, re-press the button.



Auto restart

In case the power comes on again after a power failure, Auto Restarting Operation is the function to operate procedures automatically to the previous operating conditions.

So there is no need of activating this function by pressing any key or button.

In the initial mode, the fan operates at a low speed and the compressor starts 2.5~3 minutes later.

As the compressor starts, the fan speed also resumes its previous setting mode.

Helpful information

Fan speed and cooling capacity.

The cooling capacity indicated in the specification is the value when the fan speed is set to high, and the capacity will be lower at low or medium fan speed.

High fan speed is recommended when you wish to cool the room quickly.

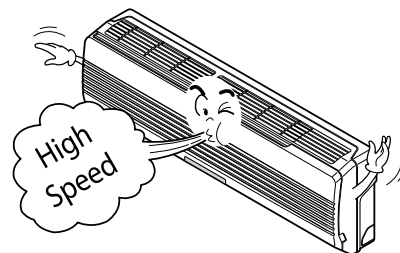

Care and maintenance of the air conditioner

CAUTION: Before performing any maintenance, turn off the main power to the system.

Indoor Unit

Grille, Case, and Remote Control

Turn the system off before cleaning. To clean, wipe with a soft, dry cloth. Do not use bleach or abrasives.

NOTE:

Supply power must be disconnected before cleaning the indoor unit.

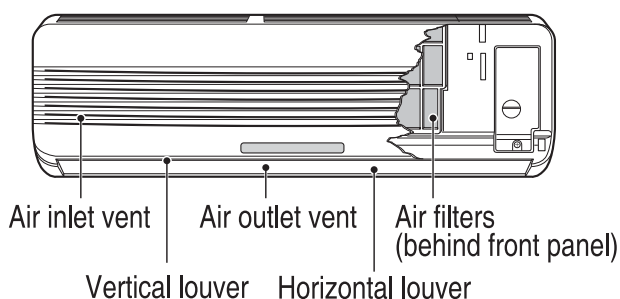

Never use any of the followings:

- Water hotter than 40 °C
Could cause deformation and/or discoloration.
- Volatile substances
- Could damage the surfaces of the air conditioner.



AIR FILTERS

The air filters behind the front grille should be checked and cleaned once in every 2 weeks or more often if necessary.

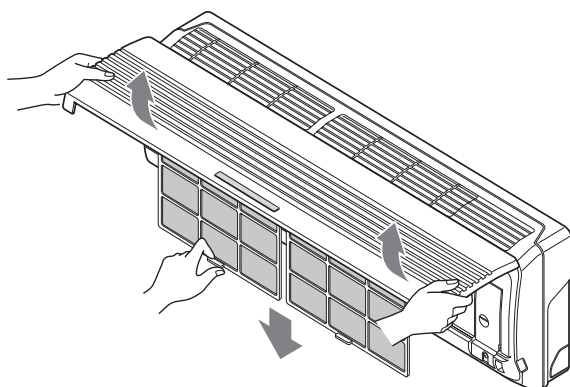

- 1 Lift the front access panel and pull the filter tab slightly forward to remove the filter.
- 2 Clean the filter with a vacuum cleaner or warm, soapy water.
 - If dirt is conspicuous, wash with a solution of detergent in lukewarm water.
 - If hot water (40 °C or more) is used, it may be deformed.
- 3 After washing with water, dry well in the shade.
- 4 Re-install the air filter.

Outdoor Unit

The heat exchanger coils and panel vents of the outdoor unit should be checked regularly. If clogged with dirt or soot, the heat exchanger and panel vents may be professionally steam cleaned.

NOTE:

Dirty or clogged coils will reduce the operating efficiency of the system and cause higher operating costs.

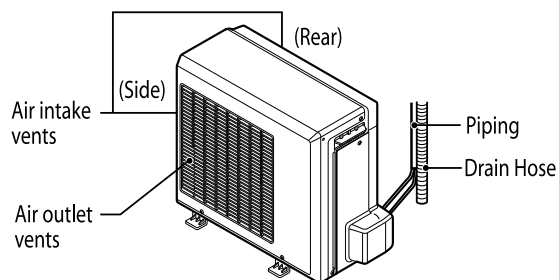
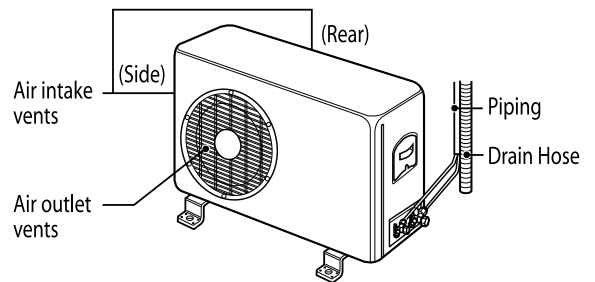
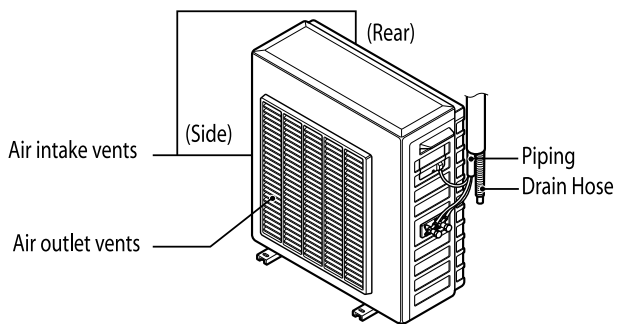

When the air conditioner is not going to be used for a long time .

When air conditioner is not going to be used for a long time.

- 1 Turn off the circuit breaker, and disconnect the plug.

CAUTION

Turn off the circuit breaker when the air conditioner is not going to be used for a long time.
Dirt may collect and may cause a fire.

- 2 Remove the batteries from the remote control.

When the air conditioner is to be used again.

- 1 Clean the air filter and install it in the indoor unit.
(Refer to page 12 for cleaning filters.)

- 2 Check that the air inlet and outlet of the indoor/outdoor unit are not blocked.

Operation Tips

Do not overcool the room.

This is not good for the health and wastes electricity.

Keep blinds or curtains closed.

Do not let direct sunshine enter the room when the air conditioner is in operation.

Keep the room temperature uniform.

Adjust the vertical and horizontal airflow direction to ensure a uniform temperature in the room.

Make sure that the doors and windows are shut tight.

Avoid opening doors and windows as much as possible to keep the cool air in the room.

Clean the air filter regularly.

Blockages in the air filter reduces the airflow and lowers the cooling and dehumidifying effects. Clean at least once in every two weeks.

Ventilate the room occasionally.

Since windows are kept closed, it is a good idea to open them and ventilate the room now and then.

Before you call for service...



Troubleshooting Tips! Save time and money!

Check the following points before requesting repairs or service.... If the fault persists, please contact your dealer or service center.

Case	Explanation	See page
The air conditioner does not operate.	•Have you made a mistake in timer operation.	9
	•Has the fuse blown or has the circuit breaker been tripped.	-
The room has a peculiar odor.	•Check that this is not a damp smell exuded by the walls, carpet, furniture, or cloth items in the room.	-
It seems that condensation is leaking from the air conditioner.	•Condensation occurs when the airflow from the air conditioner cools the warm room air.	-
Air conditioner does not operate for about 3 minutes when restarted.	•This is the protector of the mechanism. •Wait about three minutes and operation will begin.	-
Does not cool or heat effectively.	•Is the air filter dirty? See air filter cleaning instructions.	12
	•Has the temperature been set incorrectly.	6, 7
	•Are the indoor unit's air inlet or outlet vents obstructed.	-
The air conditioner operation is noisy.	•For a noise that sounds like water flowing. -This is the sound of freon flowing inside the air conditioner unit. •For a noise that sounds like the compressed air releasing into atmosphere. -This is the sound of the dehumidifying water being processed inside the air conditioning unit.	-
Remote control display is faint, or no display at all.	•Are the batteries depleted. •Are the batteries inserted in the opposite (+) and (-) directions.	4
Crack sound is heard.	•This sound is generated by the expansion/constriction of the front panel, etc. due to changes of temperature.	-

NOTE

WATER RESISTANT: The outdoor side of this appliance is WATER RESISTANT.
The indoor side is not water resistant and should not be exposed to excess water.

