



**LG**

Life's Good

OWNER'S MANUAL

# LCOS PROJECTOR

Please read this manual carefully before operating your set and retain it for future reference.

CF3DA

# LCOS PROJECTOR



The lightning flash with arrowhead symbol, within an equilateral triangle, is intended to alert the user to the presence of uninsulated "dangerous voltage" within the product's enclosure that may be of sufficient magnitude to constitute a risk of electric shock to persons.



The exclamation point within an equilateral triangle is intended to alert the user to the presence of important operating and maintenance (servicing) instructions in the literature accompanying the appliance.

## WARNING/CAUTION

- TO REDUCE THE RISK OF FIRE AND ELECTRIC SHOCK, DO NOT EXPOSE THIS PRODUCT TO RAIN OR MOISTURE.

## On Disposal (Hg lamp)

- The fluorescent lamp used in this product contains a small amount of mercury.
- Do not dispose of this product with general household waste.
- Disposal of this product must be carried out in accordance to the regulations of your local authority.

**This device meets the EMC requirements for home appliances (Class B) and is intended for home usage. This device can be used in all regions.**



HDMI, HDMI logos and High-Definition Multimedia Interface are the trademarks or registered trademarks of HDMI Licensing LLC.

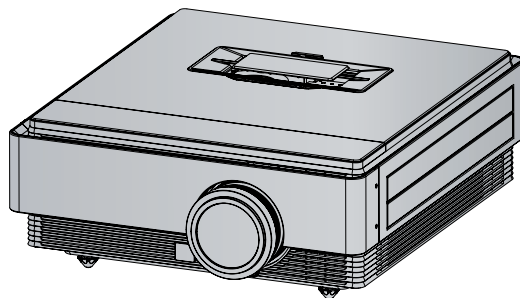

# Contents

Safety Precautions.....	4	Time Function	
<b>Parts and Components</b>		Using SLEEP Function.....	27
Main Unit.....	7	Auto Off.....	27
Control Panel.....	7	<b>Option Functions</b>	
Back.....	8	Selecting a Language.....	28
Name of remote control buttons.....	9	Using the Blank Image Function.....	29
How to insert a battery.....	9	Selecting the Blank Image Color.....	29
Projector Status Indicators.....	10	Camera Calibration.....	29
Accessories.....	11	To adjust the brightness of the screen,.....	30
Optional Extras.....	11	High Altitude.....	30
<b>Installation and Configuration</b>		Network Settings.....	30
Caution on Installation.....	12	Setting SET ID.....	32
Projection Distance per Screen Size.....	13	Setting the Name of a Connected Device.....	32
Turning on the Projector.....	14	Setting Power Sound.....	32
Turning off the Projector.....	14	<b>Information Function</b>	
Focus and Position of the Screen Image.....	15	Checking Projector Information.....	32
Selecting Input Signal.....	15	<b>Serial Communication Function</b>	
<b>Connecting Device</b>		Establishing Serial Communication.....	33
Connecting to a PC.....	16	Communication Protocol.....	33
Connecting to a Video Player.....	16	Communication using Hyper Terminal.....	39
Connecting to a DVD Player.....	17	<b>Miscellaneous</b>	
Connecting to a DTV Set-Top Box.....	17	Supported Monitor Display.....	41
<b>3D Function</b>		Maintenance.....	42
Caution When Watching 3D Video.....	18	Do not turn off the projector.....	44
Requirements for Watching 3D Images.....	18	Troubleshooting.....	46
Watching 3D Images.....	19	Product Specifications.....	47
Setting 3D Mode.....	20	Open Source software Information.....	48
Exiting 3D Mode.....	20		
<b>Function</b>			
<b>Video Function</b>			
Picture Mode.....	21		
Adjusting Color Temperature.....	21		
Adjusting Picture Settings.....	22		
Advanced Options.....	22		
Picture Initialization Function.....	24		
TruMotion Demo Function.....	24		
<b>Screen Function</b>			
Using the Pause Function.....	24		
Using the Screen Size Function.....	25		
Test Pattern Function.....	25		
Using Keystone.....	25		
Changing Projection Mode.....	25		
Using the AUTO Function.....	26		
Adjusting PC Input.....	26		

# Safety Precautions

Please take note of the safety instructions to prevent any potential accident or misuse of the projector.

- **Safety Instructions are given in two forms, i.e. 'Warning' and 'Notes' as detailed below.**

 **Warning:** The violation of this instruction may cause serious injury and even death.

 **Note:** The violation of this instruction may cause injury or damage to the projector.

- **Read the owner's manual carefully and keep it at hand.**

## Indoor Installation Warning

**Do not place the projector in direct sunlight or near heat sources such as radiators, fires, stoves etc.**

There is risk of fire.

**Do not place flammable materials such as aerosols near the projector.**

There is risk of fire.

**Do not allow children to hang from or climb on the projector.**

This may cause the projector to fall, causing injury or death.

**Do not install the product in a place with no ventilation (e.g., on a bookshelf or in a closet) or on a carpet or cushion.**

Failure to do so may result in a fire due to the increase in the internal temperature.

**Do not place the projector close to sources of steam or oil such as a humidifier or kitchen counter.**

This may create a fire hazard or cause electric shock.

**Do not place the projector where it might be exposed to dust.**

There is risk of fire.

**Do not use the projector in a damp place such as a bathroom where it is likely to get wet.**

This may create a fire hazard or result in electric shock.

**Make sure the air vent is not blocked by a tablecloth or curtain.**

Failure to do so may result in a fire due to the increase in the internal temperature.

**Ensure good ventilation around the projector. The distance between the projector and the wall should be more than 30 cm.**

Failure to do so may result in a fire due to the increase in the internal temperature.

## Indoor Installation Caution

**When placing the projector on a table or shelf, be careful not to put it near the edge.**

The projector could fall, causing injury, and damage to the projector. Only use a suitable stand.

**Disconnect the projector from the power supply and all connected apparatus before moving or cleaning.**

The power cord may be damaged and may create a fire hazard or result in electric shock.

**Do not place the projector on an unstable or vibrating surface such as a wobbly shelf or a slope.**

It may fall and cause injury.

## Power Warning

**The earth cable should be connected.**

Ensure that you connect the earth cable to prevent possible electric shock. If it is not possible to ground the unit, have a qualified electrician install a separate circuit breaker. Do not try to ground the projector by connecting it to telephone wires, lightning rods or gas pipes.

**The power plug should be inserted fully into the power outlet.**

An unstable connection may cause a fire.

**Do not place heavy objects on the power cord.**

This may create a fire hazard or cause electric shock.

**Power**  **Warning**

<p><b>Never touch the power plug with wet hands.</b></p> <p>The fluid can cause blindness.</p>	<p><b>Do not plug too many devices into one multi-power outlet.</b></p> <p>This may result in the power outlet overheating and creating a fire hazard.</p>	<p><b>Prevent dust from collecting on the power plug pins or outlet.</b></p> <p>The fluid can cause blindness.</p>
--	--	--

**Power**  **Caution**

<p><b>Hold the plug firmly when unplugging.</b></p> <p>A damaged wire may create a fire hazard.</p>	<p><b>Ensure the power cord and plug are not damaged, modified, severely bent, twisted, pulled, sandwiched or hot. Do not use the product if the power outlet is loose.</b></p> <p>This may create a fire hazard or cause electric shock.</p>	<p><b>Keep the power cord away from heating devices.</b></p> <p>The wire coating may melt, which may cause a fire or result in electric shock.</p>
---	---	--

<p><b>Place the projector where people will not trip over or tread on the power cord to protect the power cord and plug from any damage.</b></p> <p>This may create a fire hazard or cause electric shock.</p>	<p><b>Do not turn the projector on/off by plugging in the power plug or unplugging it from the power outlet. (Do not use the power plug as a switch.)</b></p> <p>This may create a fire hazard or result in electric shock.</p>
--	---

**When in Use**  **Warning**

<p><b>Do not place anything containing liquid on top of the projector such as a flower vase, flower pot, cup, cosmetics, or medicine; or ornaments, candles, etc.</b></p> <p>This may create a fire hazard, result in electric shock, or cause injury due to falling.</p>	<p><b>In the event that there is a big impact shock or the cabinet is damaged, switch it off, unplug it from the power outlet and contact an authorized service center.</b></p> <p>This may create a fire hazard or cause electric shock.</p>	<p><b>Do not insert pieces of metal such as coins, hairpins or metal debris, nor flammable materials such as paper or matches into the projector.</b></p> <p>This may create a fire hazard or cause electric shock.</p>
---	---	---

<p><b>In the event that liquid or a foreign object falls into the projector, please switch it off and unplug it from the power outlet and contact an LG Electronics Service Center.</b></p> <p>This may create a fire hazard or cause electric shock.</p>	<p><b>Make sure that a child does not swallow the batteries when you replace the old remote control batteries with new ones. Keep batteries out of reach of children.</b></p> <p>If a child swallows a battery, consult a doctor immediately.</p>
---	---

<p><b>Do not remove any covers except the lens or dust covers. There is a high risk of electric shock.</b></p>	<p><b>Do not look directly into the lens when the projector is in use. The strong light may damage your eyes.</b></p>	<p><b>When the lamp is on or has just been turned off, avoid touching the air vent or lamp cover because they will be very hot.</b></p>
--	---	---

**When in Use**  **Warning**

<p><b>If there is a gas leak, do not touch the power outlet, and open the windows for ventilation.</b></p>	<p><b>Always open the lens door and remove the lens cap when the projector lamp is on.</b></p>
<p>Sparks may cause fire or burns.</p>	

**When in Use**  **Caution**

<p><b>Do not place heavy objects on the projector.</b></p>	<p><b>Be careful not to allow impact to the lens during transport.</b></p>	<p><b>Do not touch the lens. The lens may be damaged.</b></p>
<p>It may fall and cause injury.</p>		
<p><b>Do not use any sharp tools on the projector such as a knife or hammer, because this may damage the casing.</b></p>	<p><b>In the event that no image appears on the screen, please switch off the projector, unplug it from the power outlet and contact the LG Electronics Service Center.</b></p>	<p><b>Do not drop anything onto the projector or allow anything to impact the projector.</b></p>
	<p>This may create a fire hazard or cause electric shock.</p>	<p>This may cause mechanical failure or personal injury.</p>

**Cleaning**  **Warning**

<p><b>Do not spray the projector with water when cleaning. Make sure water does not flow into the projector.</b></p>	<p><b>In the unlikely event of smoke or a strange smell coming out from the projector, switch it off, unplug it from the power outlet and contact the LG Electronics Service Center.</b></p>	<p><b>Use an air spray or soft cloth or cotton swab moistened with a lens cleaning chemical or alcohol to remove dust or stains on the front projection lens.</b></p>
<p>This may create a fire hazard or cause electric shock.</p>	<p>Otherwise, it may create a fire hazard or result in electric shock.</p>	

**Cleaning**  **Caution**

<p><b>You need to clean the projector periodically.</b></p>	<p><b>When cleaning plastic parts such as the projector case, unplug the power first and wipe with a soft cloth. Do not spray with water or wipe with a wet cloth. Never use glass cleaner, automobile or industrial shiner, abrasives or wax, benzene, alcohol etc., which can damage the projector.</b></p>
<p>If you do not clean the projector, dust will accumulate inside and may create a fire hazard or malfunction.</p>	<p>This may create a fire hazard, result in electric shock or product damage (deformation, corrosion or breakage).</p>

**Miscellaneous**  **Warning**

<p><b>Only a qualified technician can disassemble or modify the projector. For diagnosis, adjustment, or repair, contact your seller or service center.</b></p>
<p>This may create a fire hazard or cause electric shock.</p>

**Miscellaneous**  **Caution**

<p><b>Do not mix new batteries with old ones.</b></p>	<p><b>Be sure to unplug if the projector is not to be used for a long period.</b></p>	<p><b>Only use the specified type of battery.</b></p>
<p>Burst or leaking batteries are a fire hazard or may result in electric shock.</p>	<p>Accumulated dust is a fire hazard and may result in electric shock due to overheating, ignition, or poor insulation.</p>	<p>Burst or leaking batteries are a fire hazard or may result in electric shock.</p>

# Parts and Components

## Main Unit

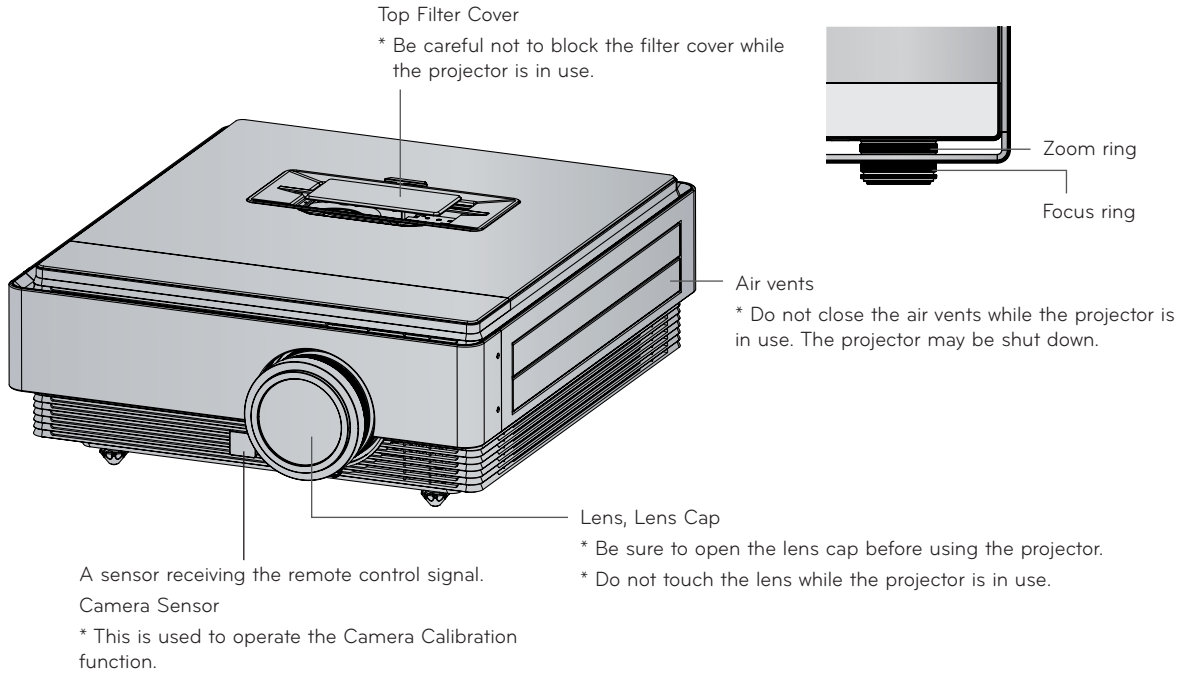

## Control Panel

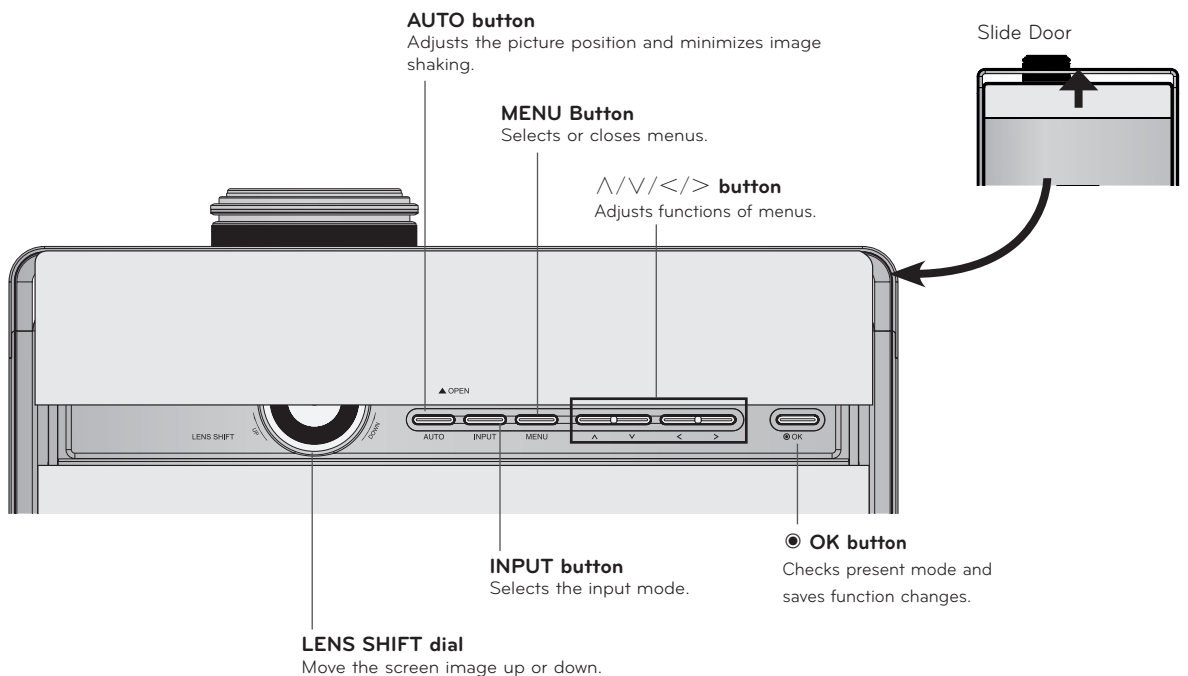

Back

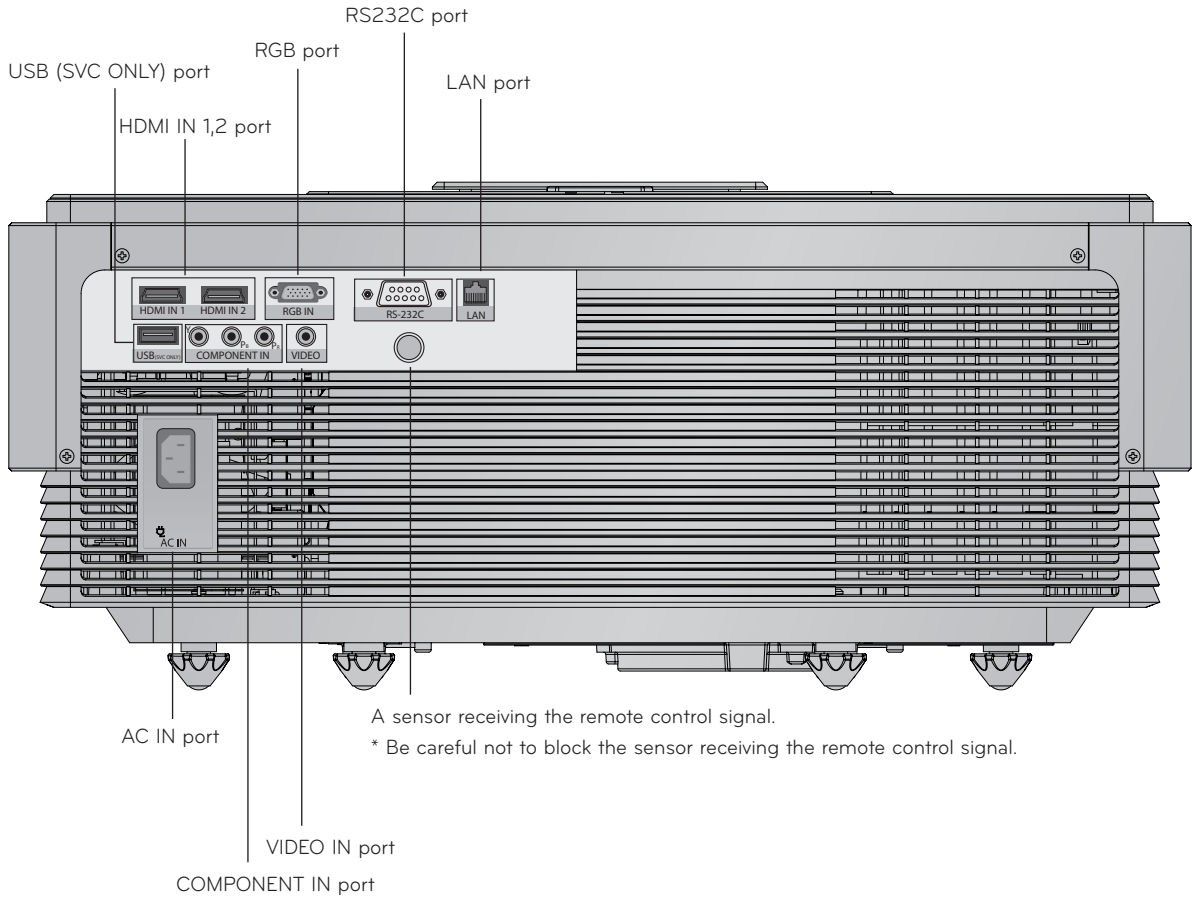

## Name of remote control buttons



## How to insert a battery

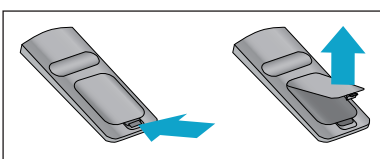

- Open the lid at the back of the remote control and insert batteries as described by the + - instructions.
- Use new batteries of the same kind (1.5V AAA).

## Projector Status Indicators

\* |Lamp indicator, operation indicator and temperature indicator at the top of the projector show the user the operating status of the projector.

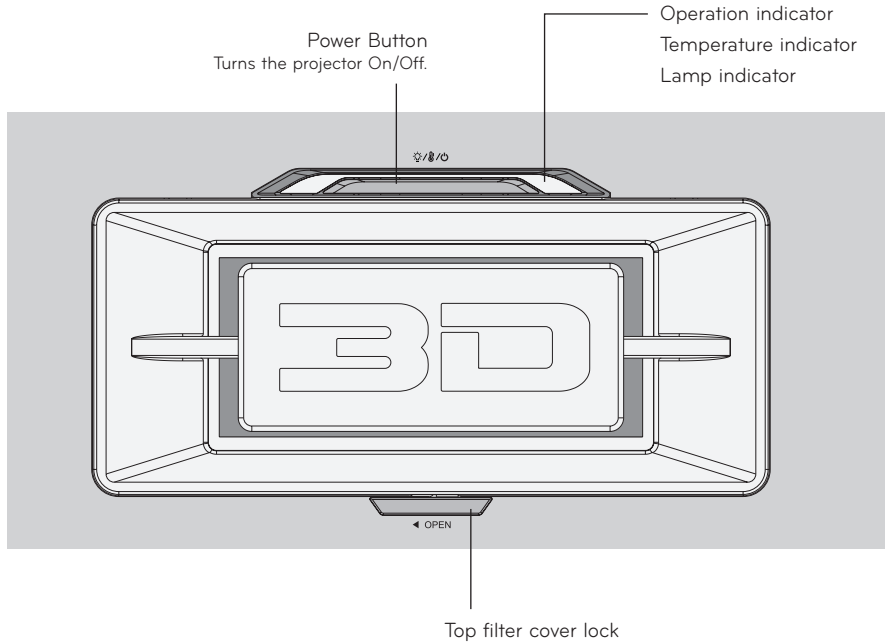

Display	Blue	Standby.
	Green (Blinking)	On
	Green	The projector is in use.
	Cyan (Blinking)	Power off (It takes about 90 seconds for the lamp to switch off completely.).
Temperature	Red (Blinking)	An error has occurred in the internal cooling fan.
	Yellow	High temperature warning.
	Yellow (Blinking)	The projector is automatically turned off due to excessive heat.
Lamp	Magenta	The lamp is reaching the end of its life and needs to be replaced with a new lamp.
	Magenta (Blinking)	An error has occurred in the lamp.
	Red	The lamp cover is open.
Air vent	Cyan	An error has occurred in the air vent.
Filter	Blue (Blinking)	The filter cover is open.

### Accessories



REMOTE CONTROL



Battery (AAA) 2EA

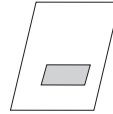

User Guide

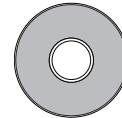

CD User Guide



Power Cord



Polishing Cloth

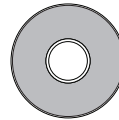

eZ-Net Manager CD



3D Glasses



Top Filter



Bottom Filter

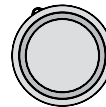

Lens Cap

### Optional Extras

To purchase optional accessories, visit an electronics store or online shopping site or contact the retail store where you purchased the product.

Without prior notice, optional accessories are subject to change to improve the performance of the product, and new accessories may be added.

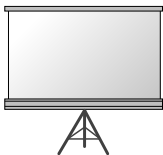

Projection Screen (3D)

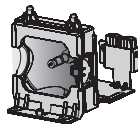

Lamp



Computer Cable



HDMI Cable

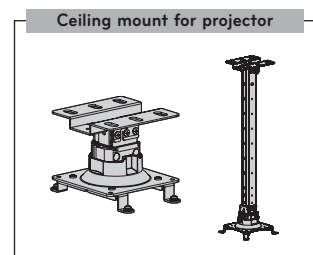

Video Cable



Component Cable



LAN cable



3D Glasses



RS-232C cable

# Installation and Configuration

## Caution on Installation

### Place the projector in a well-ventilated environment.

- To prevent internal heat build-up, install the projector in a well-ventilated place. Do not place anything near the projector as this may block its air vents. If the air vents are blocked, the internal temperature will increase.
- Do not place the projector on a carpet or rug. This may prevent proper ventilation at the bottom of the projector. This product should be mounted onto a flat surface or ceiling only.

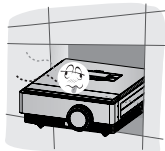

- Be sure to prevent foreign objects such as paper debris from entering the projector.
- Leave an adequate distance (30 cm or more) around the projector.



### Do not place the projector in a hot or humid environment.

- Only install the projector in a place of moderate temperature and low humidity. (See page 47 regarding operating temperature and humidity.)

### Do not place the projector in a place where it will easily attract dust.

- There is risk of fire.

### Do not remove any covers except for the lens cap. There is a high risk of electric shock.

### The projector is manufactured using high-precision technology. You may, however, see tiny black dots and/or bright colored dots (red, blue or green) that continuously appear on the projector screen. This is a normal result of the manufacturing process and does not indicate a malfunction.

### The remote control may not work in an environment where a lamp equipped with electronic ballasts or a three-wave-length fluorescent lamp is installed. Replace the lamp with an internationally standardized lamp for the remote control to work normally.

### Projection Distance per Screen Size

- Place the projector on a sturdy, level surface, together with the PC or audio/video source.
  1. The distance between the projector and the screen determines the actual size of the image.
  2. Position the projector so that the lens is set at a right angle to the screen. If the projector is not set at a right angle, the image on the screen will be crooked. If the screen image is crooked, use the **Keystone function**.
  3. Connect the power cords of the projector and any connected devices to the power outlet.

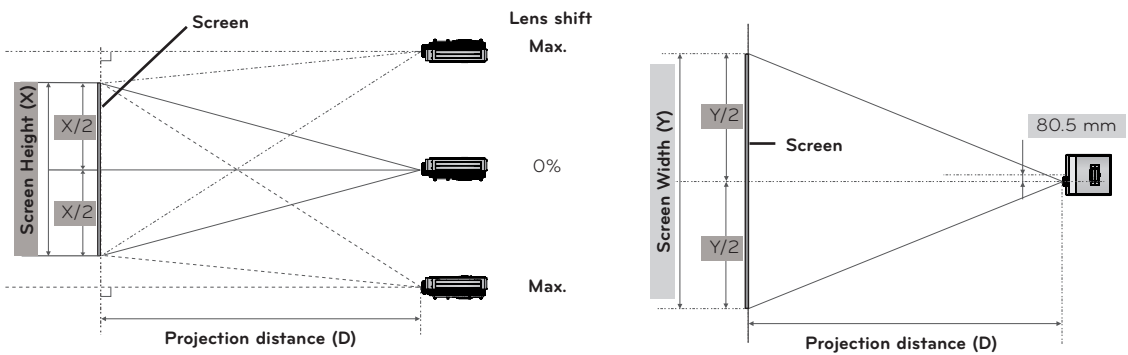

16:9 Aspect Ratio				
Screen			Projection Distance	
Screen Size (mm)	Screen Width (Y) (mm)	Screen Height (X) (mm)	Min. projection distance (D1) (m)	Max. projection distance (D2) (m)
762	664	374	0.87	1.15
1016	886	498	1.17	1.54
1270	1107	623	1.48	1.94
1524	1328	747	1.78	2.33
1778	1550	872	2.09	2.73
2032	1771	996	2.39	3.13
2286	1992	1121	2.70	3.52
2540	2214	1245	3.00	3.92
2794	2435	1370	3.31	4.32
3048	2657	1494	3.61	4.72
3302	2878	1619	3.92	5.11
3556	3099	1743	4.22	5.51
3810	3321	1868	4.53	5.91
4064	3542	1992	4.83	6.30
4318	3763	2117	5.13	6.70
4572	3985	2241	5.44	7.10
4826	4206	2366	5.74	7.49
5080	4428	2491	6.04	7.89
5334	4649	2615	6.35	8.29
5588	4870	2740	6.66	8.68
5842	5092	2864	6.96	9.08
6096	5313	2989	7.27	9.48
6350	5535	3113	7.57	9.87
6604	5756	3238	7.88	10.27
6858	5977	3362	8.18	10.67
7112	6199	3487	8.49	11.06
7366	6420	3611	8.79	11.46
7620	6641	3736	9.10	11.86

### Turning on the Projector

1. Connect the power cord correctly to turn the projector on.
2. Press the **POWER** button. **The power indicator blinks green.**
  - Power on time is long due to the characteristics of the 3D projector.
  - Press the **INPUT** button to select an input signal.
  - There will be a brief sound when the projector is turned on.
  - Check if the lens cap is open before turning on the projector.

### Turning off the Projector

1. Press the **POWER** button.

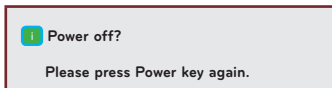

2. The unit will turn off when you press the **POWER** button a second time. Do not disconnect the power cord if the operation indicator is cyan, This indicates the fan is still running (90 seconds). Disconnect the power cord when the operation indicator becomes blue.

## Focus and Position of the Screen Image

When an image appears on the screen, check if it is in focus and fits the screen properly.

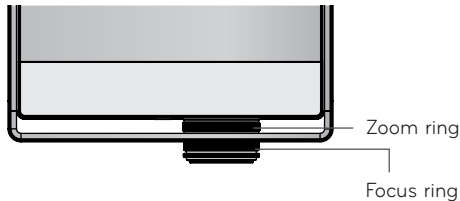

- To adjust the focus of the image, rotate the focus ring.
- To adjust the size of the image, rotate the zoom ring.

If you need to move the screen image up or down, use the lens shift dial at the top of the projector to adjust the height as shown below.

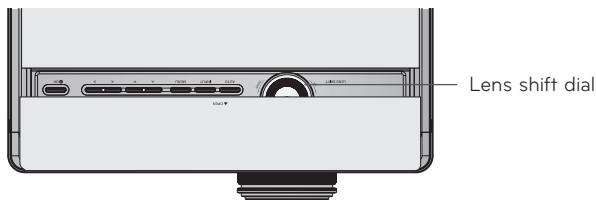

- Turn the LENS SHIFT dial left or right to adjust the projected image position up or down.
- Turning the LENS SHIFT dial with excessive force may cause damage to the projector.

## Selecting Input Signal

1. Press the **INPUT** button.
2. Select an input signal using the remote control's **INPUT** button to connect the projector to the desired input. You can toggle between inputs using the **<**, **>** buttons.

### Input List



- You can also select an input signal directly using the **VIDEO**, **COMPONENT**, **RGB**, **HDMI1** and **HDMI2** buttons of the remote control.
- The connected input is displayed first.

# Connecting Device

## Connecting to a PC

- \* You can connect the projector to a computer with an VGA, SVGA, XGA or SXGA output.
- \* See page 41 for a list of supported monitors.

### <How to Connect>

Connect the projector's **RGB IN** port to the computer's RGB output port using a computer cable.

- \* For IBM PC/AT-compatible laptops, video can be displayed on both the laptop monitor and the external one. If the video is displayed on both, the image quality on the external monitor may not be satisfactory. In this case, configure the laptop's video output to the external monitor only. (For more detailed information, refer to your laptop's user manual.)



Computer Cable

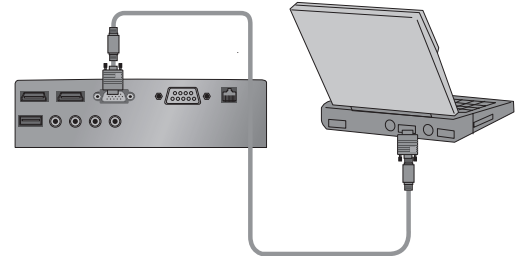

Computer Cable

## Connecting to a Video Player

### <How to Connect>

Connect the projector's **VIDEO** port to the audio/video device's output jack using a video cable.

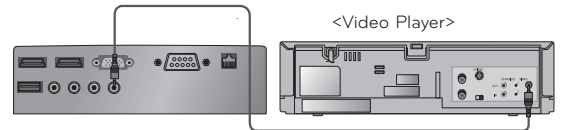

Video Cable

## Connecting to a DVD Player

\* The output jack Y, Pb or Pr of the DVD player may be marked as Y, Pb, Pr/Y, B-Y, R-Y/Y, Cb, or Cr depending on the model.

### <Connecting to the HDMI Port>

1. Connect the projector's **HDMI IN 1** (or **HDMI IN 2**) port to the DVD player's HDMI port using an HDMI cable.
2. Set the DVD player's resolution to one of the following: 480p (576p), 720p, 1080i, or 1080p.

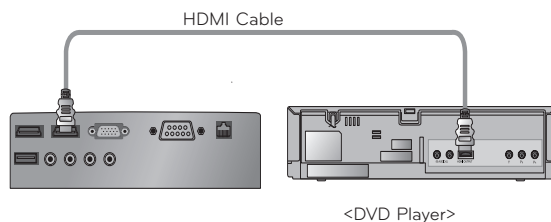

### <Connecting to the COMPONENT Port>

Turn on the projector, then turn on the HDMI device.

### <Connecting to the COMPONENT Port>

Connect the projector's **COMPONENT IN** port to the DVD player's output port using a component cable.

\* Match the jack colors to the component cable when connecting. (Y=Green, PB=Blue, PR =Red)

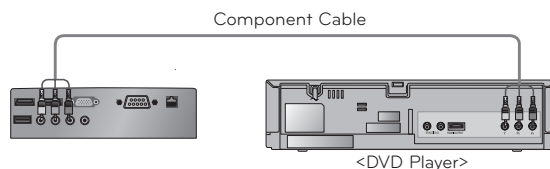

## Connecting to a DTV Set-Top Box

\* Please refer to the user manual of the DTV set-top box to connect to the projector, as well as for instructions on how to use the DTV set-top box.

### <Connecting to the HDMI Port>

1. Connect the projector's **HDMI IN 1** (or **HDMI IN 2**) port to the DTV set-top box's HDMI port using an HDMI cable.
2. Set the DTV's resolution to one of the following: 480p (576p), 720p, 1080i, or 1080p.

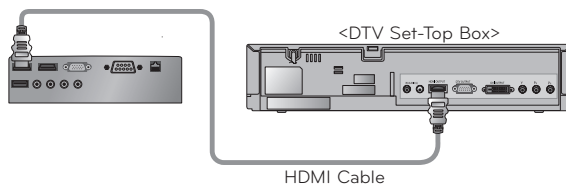

### <Connecting to the COMPONENT Port>

Turn on the projector, then turn on the HDMI device.

### <Connecting to the COMPONENT Port>

Connect the projector's **COMPONENT IN** port to the DTV set-top box's output port using a component cable.

\* Match the jack colors to the component cable when connecting. (Y=Green, PB=Blue, PR =Red)

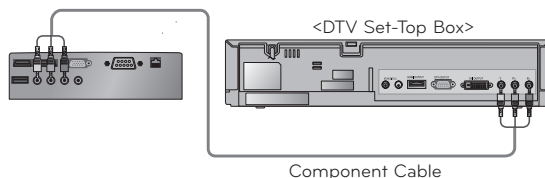

## 3D Function

\* 3D technology uses different video frames for each eye to add depth to the video.

\* 3D images can be viewed only on a silver screen.

### Caution When Watching 3D Video

- ▶ **Watch 3D images within the optimum viewing angle and distance.**
  - If you are outside the optimum viewing angle or distance, you may not be able to watch 3D images.
- ▶ **If you view 3D images too closely for a long period of time, this may cause blurred vision.**
- ▶ **If you view 3D images wearing 3D glasses for a long period of time, this may cause drowsiness or eye strain.**
  - You should stop watching if you experience a headache, fatigue or dizziness.
- ▶ **If you are pregnant, a senior, have heart problems or easily feel motion sickness, we recommend you do not view 3D images.**
  - Because 3D images can cause disorientation and confusion, some viewers may get surprised or overexcited.
- ▶ **Do not watch 3D images near fragile objects or any objects that can be knocked over easily.**
  - If you are startled or misconstrue the 3D images as real, you may knock over a nearby object or injure yourself trying to move your body.
- ▶ **Do not use 3D glasses as ordinary glasses, sunglasses or protective goggles. If you do so, this may cause injury.**
- ▶ **Do not store 3D glasses in very hot or very cold conditions. If you do so, this may cause them to become deformed.**
- ▶ **The lenses of 3D glasses (polarizing film) are easily scratched. Use a soft clean cloth when cleaning them.**
  - Be careful because any foreign particles on the cloth may result in scratches.
- ▶ **Do not scratch the surface of 3D glasses' lenses (polarized film) with sharp objects or wipe them with chemicals.**
  - If the polarized film gets scratched, images may not look normal when viewing 3D.
- ▶ **The lenses of 3D glasses are different from those of ordinary glasses and very thin. Therefore, handle the glasses with care as the lenses can be popped out easily.**
- ▶ **Photosensitivity seizure warning – Some users may experience a seizure or other abnormal symptoms when they are exposed to a flashing light or particular pattern from a video game or movie. If anyone in your family has a history of epilepsy or has ever experienced any kind of seizure, please consult your doctor before viewing 3D images. You may exhibit any of the symptoms listed below even if you do not have previous medical problems of this nature.**
  - Dizziness, fatigue, twitching of the eye or face muscles, involuntary movements, cramp, loss of consciousness, confusion, loss of sense of direction, or nausea

If you exhibit any of these symptoms when viewing 3D images, please stop viewing immediately and consult your doctor. Extra special care is required for children watching 3D video. You can reduce the risk of photosensitive seizures with the following preventive measures.

  - Do not watch 3D video when very sleepy, tired or sick, and avoid watching 3D video for a long period of time.

### Requirements for Watching 3D Images

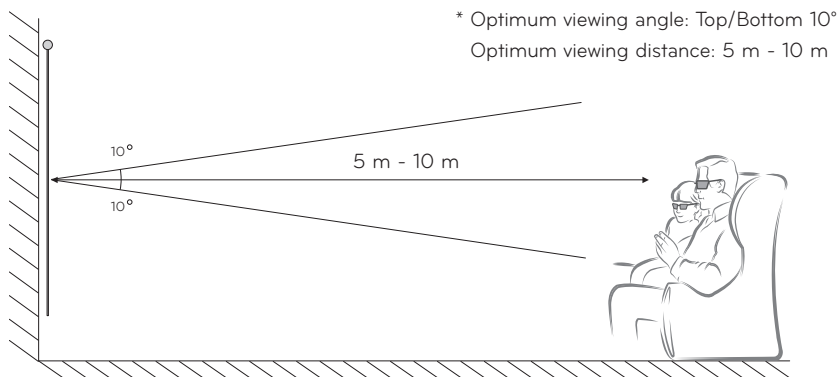

### Note!

- Some menus may not work while playing 3D video.
- You can watch 3D video properly only when the 3D video format option has been selected on the projector.

## Watching 3D Images

1. You can play supported 3D video titles. Please refer to the table below for supported 3D video formats.

	Signal	Resolution	Horizontal Frequency (kHz)	Vertical Frequency (Hz)	Supported 3D Formats
HDMI	720P	1280 x 720	45.00	60	Top & Bottom, Side by Side HDMI 3D Top & Bottom
			37.50	50	
			90.00	60	HDMI 3D Frame Packing
			75.00	50	
	1080i	1920 x 1080	33.75	60	Top & Bottom, Side by Side HDMI 3D Side by Side (Half)
			28.125	50	
	1080p	1920 x 1080	27.00	24	Top & Bottom, Side by Side, Checker Board, Frame Sequential HDMI 3D Top & Bottom
			54.00	24	
			33.75	30	Top & Bottom, Side by Side, Checker Board, Frame Sequential
			67.50	60	
		56.25	50		
RGB	1080p	1920 x 1080	66.587	59.934	Top & Bottom, Side by Side

- To play videos and media in HDMI 3D Frame Packing, HDMI 3D Side by Side or HDMI 3D Top & Bottom, the player need to support these formats.
- HDMI 3D Frame Packing, HDMI 3D Side by Side or HDMI 3D Top & Bottom formatted video is converted into stereoscopic format automatically.

2. Press the **3D button** and select **OK**.

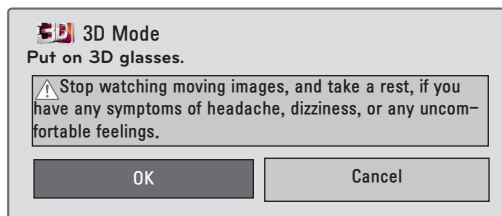

3. Press the < or > button to select the picture display format to be shown on the screen, then put on your 3D glasses.

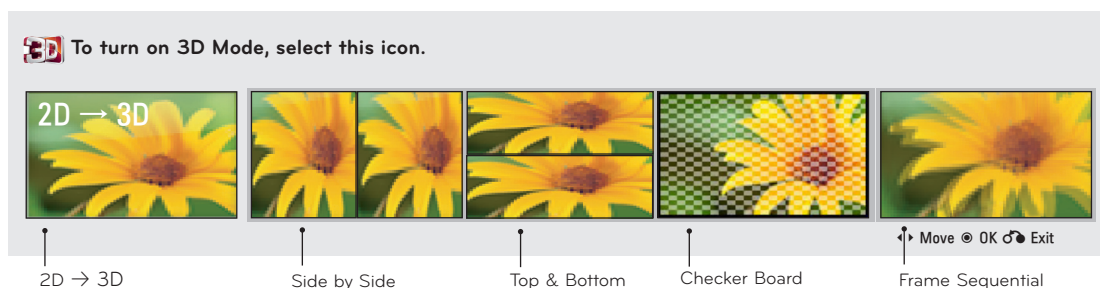

- When you select 2D → 3D, you can watch 2D video as 3D video.
- The image quality of 2D → 3D video may be not as good as that of a video title originally made in 3D.

4. Press the 3D button during viewing to exit 3D mode and watch 2D video.

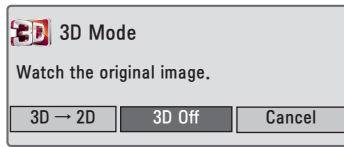
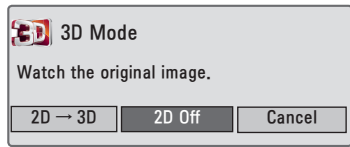

Option	Description
3D 2D	Watch 3D image in 2D mode.
3D Off	Watch the original image.
2D 3D	Show 3D effects.
Cancel	Watch the original image.

### Setting 3D Mode

Option	Description
3D Mode Setting	3D Picture Correction Switches left/right videos. Select a 3D video of better picture quality.
	3D Depth Adjusts the stereoscopic effect of the 3D image converted from a 2D image.
	3D Viewpoint Moves the 3D image forwards and backwards to adjust the 3D perspective view.
Set Video	See the Video Function - Screen Function sections.

### Exiting 3D Mode

<3D Mode>

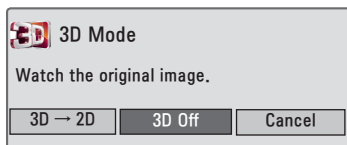

<3D to 2D Mode>



# Function

\* The On-Screen Display (OSD) in this manual is an example to help you understand how to operate the product, and may be slightly different to your projector.

\* This manual mostly describes the operation of RGB (PC) mode.

## Video Function

### Picture Mode

\* The best picture quality is maintained according to the selected picture option.

1. Press the **PICTURE** button on the remote control.
2. Press the  $\wedge$ ,  $\vee$  buttons to select a picture option.

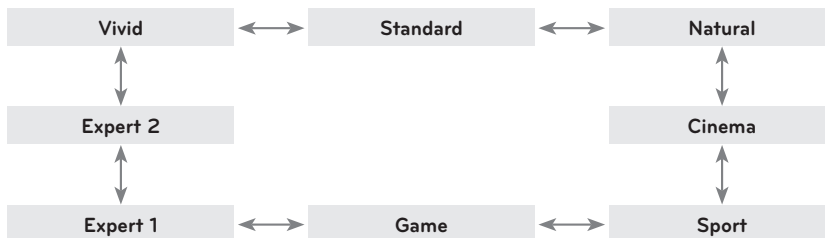

- You can also use the **MENU** or **Q.MENU** button.
- Press the **BACK** button to exit the menu screen.

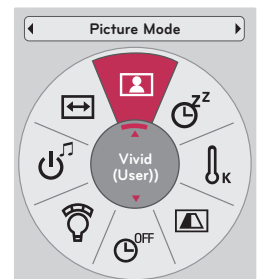

### Adjusting Color Temperature

1. Press the **Q.MENU** button on the remote control.
2. Press the  $<$ ,  $>$  buttons to go to COLOR TEMP.
3. Press the  $\wedge$ ,  $\vee$  buttons to select a picture option.

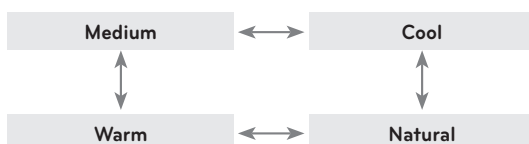

- This function is available only for **Vivid/Standard/Natural/Cinema/Sport/Game**.
- You can select this function through the **MENU** button.
- Press the **BACK** button to exit the menu screen.

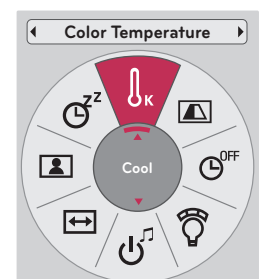

## Adjusting Picture Settings

1. Press the **MENU** button, then go to Picture with the  $\wedge$ ,  $\vee$ ,  $\lt$ ,  $\gt$  buttons and press **OK**.
2. Press the  $\wedge$ ,  $\vee$  buttons to go to a desired picture option and press **OK**.
3. Press the  $\lt$ ,  $\gt$  buttons to adjust the picture settings and press **OK**.

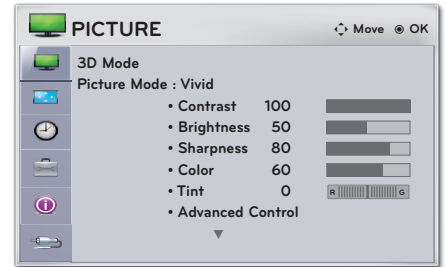

- For each option and Picture Mode, you can set different picture preference values.
- If you save your settings after configuration, (User) is displayed in the picture. (excluding Expert 1/2)
- If you want to reset to factory defaults after picture configuration, initialize each Picture Mode.
- Press the **BACK** button to exit the menu screen.

## Advanced Options

1. Press the **MENU** button, then go to Picture with the  $\wedge$ ,  $\vee$ ,  $\lt$ ,  $\gt$  buttons and press **OK**.
2. Press the  $\wedge$ ,  $\vee$  buttons to go to Advanced Control and press **OK**.
3. Press the  $\wedge$ ,  $\vee$  buttons to go to a desired item.
4. Press the  $\lt$ ,  $\gt$  buttons to adjust the picture settings and press **OK**.

<Picture Mode is in **Vivid/Standard/Natural/Cinema/Sport/Game mode**>

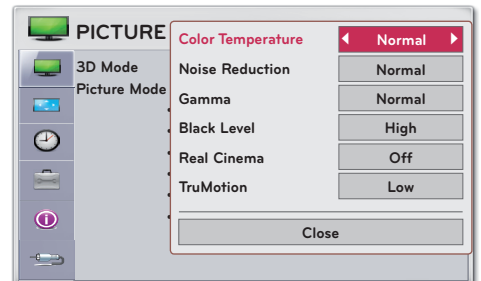

- For each option and Picture Mode, you can set different picture preference values.
- If you want to reset to factory defaults after picture configuration, initialize each Picture Mode.
- Press the **BACK** button to exit the menu screen.

<Picture Mode is in **Expert1/2 mode**>

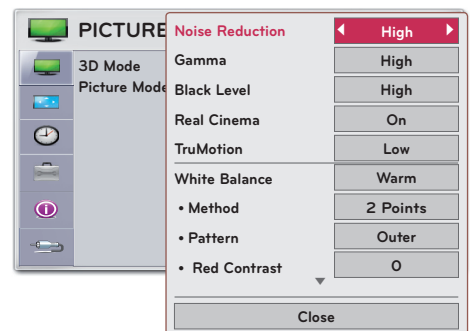

\* Configurable options may differ depending on input signal or video settings, etc.

<b>Color Temperature</b>	<ul style="list-style-type: none"> <li>- This function is available only for <b>Vivid/Standard/Natural/Cinema/Sport/Game</b>.</li> <li>• You can select the screen color.</li> </ul>
<b>Noise Reduction</b>	<ul style="list-style-type: none"> <li>• Reduces image noise.</li> </ul>
<b>Gamma</b>	<ul style="list-style-type: none"> <li>• Sets a gradation curve between video input and output signal. You can select <b>Medium/High/Low</b>.</li> </ul>
<b>Black Level</b>	<ul style="list-style-type: none"> <li>• Compensates the brightness and contrast of a screen to balance with the black level of the video input. You can select <b>Low/High</b>. <ul style="list-style-type: none"> <li>• If the black of a screen is saturated or hazy, you can adjust it with <b>High</b> or <b>Low</b>.</li> <li>• This is not available for <b>RGB</b> input.</li> </ul> </li> </ul>
<b>Real Cinema</b>	<ul style="list-style-type: none"> <li>• Provides optimal picture quality for watching a cinema. You can select <b>On</b> or <b>Off</b>.</li> <li>• If the component input is 480i signal, pictures may not be smooth depending on the output format of the DVD title. In this case, set Real Cinema to <b>On</b>.</li> </ul>
<b>TruMotion</b>	<ul style="list-style-type: none"> <li>• Displays smooth video by correcting the picture. You can select <b>Off/Low/High</b>.</li> <li>• If you feel the video is not smooth with the <b>High</b> option, you can select <b>Low</b> or <b>Off</b>.</li> <li>• If the picture is set to Game, the option is switched to <b>Off</b>.</li> <li>• This is not available for PC mode.</li> <li>• When you configure the Keystone function, it is set to <b>Off</b>. To enable TruMotion, initialize the Keystone.</li> </ul>
<b>White Balance</b>	<ul style="list-style-type: none"> <li>- This function is available only for <b>Expert 1/2</b>.</li> <li>• You can select the screen color. <ol style="list-style-type: none"> <li>Method: <b>2 Points</b> <ul style="list-style-type: none"> <li>- Pattern: Inner, Outer</li> <li>- <b>Red/Green/Blue</b> Contrast, <b>Red/Green/Blue</b> Brightness: Adjustable range <b>-50</b> to <b>+50</b>.</li> </ul> </li> <li>Method: <b>20 Points IRE</b> <ul style="list-style-type: none"> <li>- Pattern: Inner, Outer</li> <li>- <b>IRE</b> (Institute of Radio Engineers) is the unit indicating the size of a video signal in <b>5, 10, 15</b> to <b>95, 100</b>.</li> <li>- Red/Green/Blue: Adjustable range <b>-50</b> to <b>+50</b> for each IRE configuration.</li> </ul> </li> </ol> </li> </ul>
<b>Color Management System</b>	<ul style="list-style-type: none"> <li>- This function is available only for <b>Expert 1/2</b>.</li> <li>• Professionals use this for test pattern-based adjustment. 6 colors (Red/Green/Blue/Cyan/Magenta/Yellow) can be adjusted without affecting other colors. No significant color change is detected for a normal video. You can adjust <b>Red/Green/Blue/Yellow/Cyan/Magenta</b> colors. <ul style="list-style-type: none"> <li>- Chroma <b>Red/Green/Blue/Yellow/Cyan, Magenta</b>: Adjustable range <b>-30</b> to <b>+30</b> for each.</li> <li>- Hue <b>Red/Green/Blue/Yellow/Cyan, Magenta</b>: Adjustable range <b>-30</b> to <b>+30</b> for each.</li> <li>- This is not available for <b>RGB</b> input.</li> </ul> </li> </ul>

## Picture Initialization Function

\* The settings for each input and Picture Mode are reset to the factory defaults.

1. Press the **MENU** button, then go to Picture with the  $\wedge$ ,  $\vee$ ,  $\lt$ ,  $\gt$  buttons and press **OK**  $\odot$ .
2. Press the  $\wedge$ ,  $\vee$  buttons to go to Picture Reset and press **OK**  $\odot$ .
3. Press the  $\lt$ ,  $\gt$  buttons to select Yes and press **OK**  $\odot$ .
  - Press the **BACK** button to exit the menu screen.

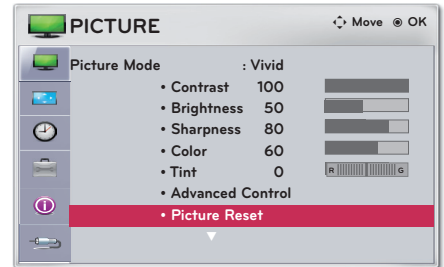

## TruMotion Demo Function

\* You can preview the live scan function.

1. Press the **MENU** button, then go to Picture with the  $\wedge$ ,  $\vee$ ,  $\lt$ ,  $\gt$  buttons and press **OK**  $\odot$ .
2. Press the  $\wedge$ ,  $\vee$  buttons to go to TruMotion Demo and press **OK**  $\odot$ .
  - This is not available for **RGB** input.
  - Press any button to exit **TruMotion Demo**.
  - Press the **BACK** button to exit the menu screen.

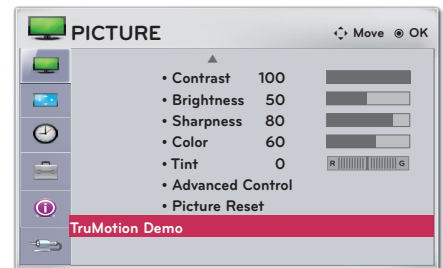

## Screen Function

### Using the Pause Function

1. Press the **PAUSE** button on the remote control.
  - \* You can temporarily stop a video being played.



<Playback Screen>



<Pause Screen>

2. To clear the pause function, press the **PAUSE** button once again.
  - \* The pause function is automatically cleared after 10 minutes.

## Using the Screen Size Function

Press the **SCREEN SIZE** button on the remote control.

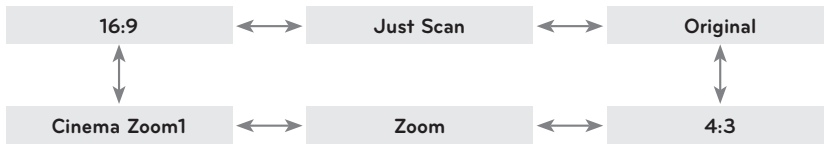

- Settings may vary depending on the input signal.
- You can also use the **MENU** or **Q.MENU** button.
- Press the **BACK** button to exit the menu screen.

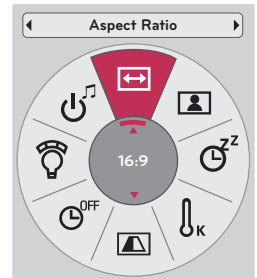

## Test Pattern Function

\* You can adjust screen size and focus while installing the projector.

Press the **TEST PATTERN** button on the remote control.

- You can select this function through the **MENU** button.

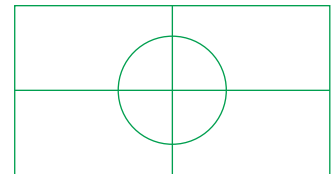

## Using Keystone

\* To prevent the screen image from becoming trapezoidal, Keystone adjusts the top and bottom width of the image if the projector is not set at a right angle to the screen.

\* Because the Keystone function may cause inferior screen image quality, use this function only when it is not possible to set up the projector at an optimal angle.

1. Press the **KEYSTONE** button on the remote control.
2. Press the  $\wedge$ ,  $\vee$  buttons to select a desired option and press the  $>$  button.
3. Press the  $\wedge$ ,  $\vee$ ,  $<$ ,  $>$  buttons to adjust the screen and press **OK**  $\odot$ .

- The Keystone is adjusted -100 to 0 or 0 to 100 depending on position.
- To reset to the factory defaults, perform **Picture Reset**.
- You can select this function through the **MENU** button.
- Press the **BACK** button to exit the menu screen.

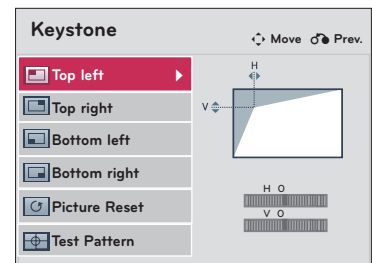

## Changing Projection Mode

\* You can flip the video up/down or left/right.

1. Press the **MENU** button, then go to Screen with the  $\wedge$ ,  $\vee$ ,  $<$ ,  $>$  buttons and press **OK**  $\odot$ .
2. Press the  $\wedge$ ,  $\vee$  buttons to go to Projection Mode and press **OK**  $\odot$ .

- Select Rear to project an image onto the back of a transparent screen purchased separately.
- Select Ceiling if you installed the projector on a ceiling.
- You can select this function through the **MENU** button.
- Press the **BACK** button to exit the menu screen.

## Using the AUTO Function

- \* AUTO provides optimized picture quality by automatically calibrating the mismatch of horizontal width and picture shake caused by clashes between the internal settings of the projector and various PC graphic signals in RGB mode.
- \* The AUTO function is available only for RGB input.

Press the **AUTO** button on the remote control.

- If you use AUTO for video signal from a PC, you may not be able to get optimized picture quality. Therefore, use the AUTO function for still images.
- You can select this function through the **MENU** button.

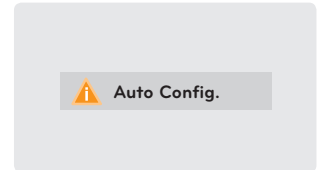

## Adjusting PC Input

1. Press the **MENU** button, then go to Screen with the  $\wedge$ ,  $\vee$ ,  $<$ ,  $>$  buttons and press **OK**  $\odot$ .
2. Press the  $\wedge$ ,  $\vee$  buttons to go to RGB Config. and press **OK**  $\odot$ .
3. Press the  $\wedge$ ,  $\vee$  buttons to select a desired option and press the  $>$  button.
4. Press the  $\wedge$ ,  $\vee$ ,  $<$ ,  $>$  buttons to adjust the screen and press **OK**  $\odot$ .
  - Available resolutions are 768 resolution (1024x768/1280x768/1360x768, 60Hz) and 1050 resolution (1400x1050/1680x1050, 60Hz).
  - Press the **BACK** button to exit the menu screen.

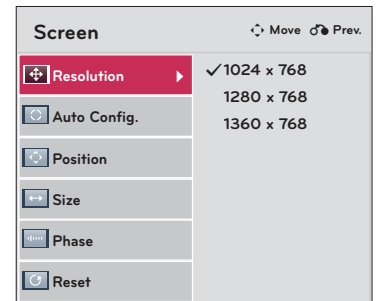

## Time Function

### Using SLEEP Function

\* The projector can be turned off at a preset time.

1. Press the **SLEEP** button on the remote control.
2. Press the  $\wedge$ ,  $\vee$  buttons to select a desired preset time.

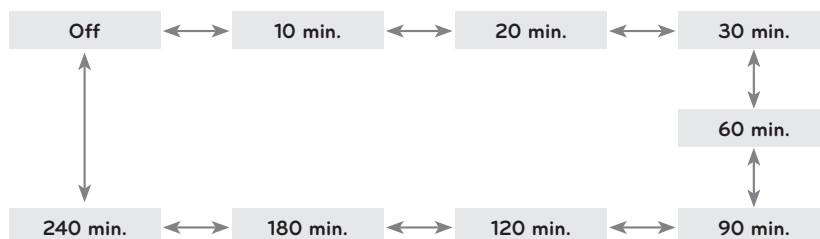

- You can also use the **MENU** or **Q.MENU** button.
- Press the **BACK** button to exit the menu screen.



### Auto Off

\* If there is no signal, the projector automatically turns off after the preset time has elapsed.

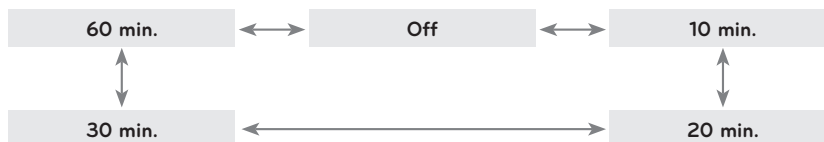

1. Press the **MENU** button, then go to Time with the  $\wedge$ ,  $\vee$ ,  $\leftarrow$ ,  $\rightarrow$  buttons and press **OK**  $\odot$ .
2. Press the  $\leftarrow$ ,  $\rightarrow$  buttons to go to **Auto Off**.
3. Press the  $\wedge$ ,  $\vee$  buttons to select a desired preset time.



- You can select this function through the **MENU** button.
- Press the **BACK** button to exit the menu screen.

## Option Functions

### Selecting a Language

1. Press the **MENU** button, then go to Options with the  $\wedge$ ,  $\vee$ ,  $\lt$ ,  $\gt$  buttons and press **OK** .
2. Press  $\wedge$ ,  $\vee$  buttons to go to Menu Language and press the **OK**  button.
3. Press  $\wedge$ ,  $\vee$ ,  $\lt$ ,  $\gt$  buttons to go to a desired item and press **OK** .
  - From now on, OSD is displayed in the selected language.
  - Press the **BACK** button to exit the menu screen.

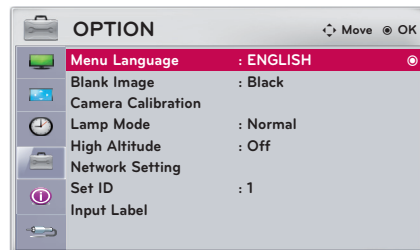

## Using the Blank Image Function

\* To attract attention during a meeting or training, use the Blank Image function.

- Press the **BLANK** button on the remote control.
  - The screen is covered by a background color.
  - For more information about selecting background color, see the Selecting the Blank Image Color section below.
- Press any button to clear the Blank Image function.
  - To cover the screen temporarily, press the **BLANK** button on the remote control. Do not block the lamp with any object while the projector is running. The object may become misshapen and blocking the lamp is a fire risk.

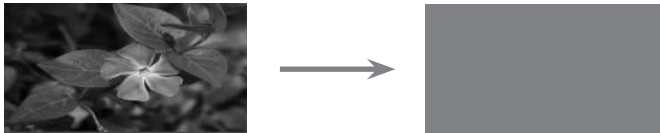

## Selecting the Blank Image Color

- Press the **MENU** button, then go to **OPTION** with the  $\wedge$ ,  $\vee$ ,  $\lt$ ,  $\gt$  buttons and press **OK**  $\odot$ .
- Press the  $\wedge$ ,  $\vee$  buttons to go to **Blank Image** and press **OK**  $\odot$ .
- Press the  $\wedge$ ,  $\vee$  buttons to go to a desired item and press **OK**  $\odot$ .
  - The selected background color will be displayed when the Blank Image function is activated.
  - Press the **BACK** button to exit the menu screen.

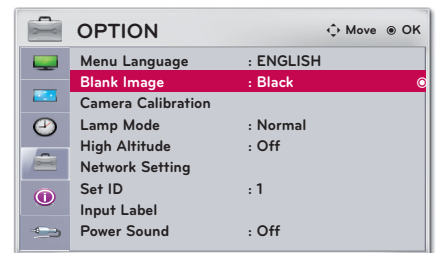

## Camera Calibration

\* This function automatically adjusts the brightness of the left and right engines of the 3D video projector, to provide a comfortable 3D video watching environment by reducing eye strain when viewing.

- Press the **MENU** button, then go to **OPTION** with the  $\wedge$ ,  $\vee$ ,  $\lt$ ,  $\gt$  buttons and press **OK**  $\odot$ .
- Press the  $\wedge$ ,  $\vee$  buttons to go to **Camera Calibration** and press **OK**  $\odot$ .
- Press the  $\lt$ ,  $\gt$  buttons to select **On**.
- Press the  $\wedge$ ,  $\vee$  buttons to go to **Start Calibration** and press **OK**  $\odot$ .

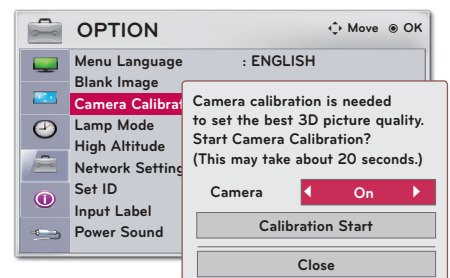

- The value input on Camera Calibration applies only to **3D video**. It does not apply to **2D video**.
- When the surrounding lighting is too bright or the TV screen size is less than 40 inches, the camera calibration may not work properly. In this case, refer to the warning message displayed on the screen.
- It operates 5 minutes after the power is turned on.
- Press the **BACK** button to exit the menu screen.

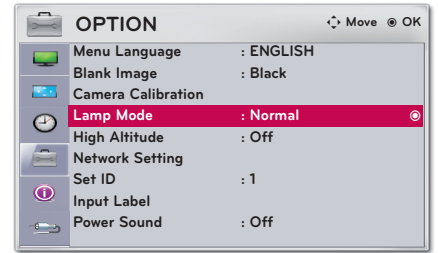

## To adjust the brightness of the screen,

1. Press the **MENU** button, then go to **OPTION** with the  $\wedge$ ,  $\vee$ ,  $\lt$ ,  $\gt$  buttons and press **OK** .
2. Press the  $\lt$ ,  $\gt$  buttons to go to **Lamp Mode**.
3. Press the  $\wedge$ ,  $\vee$  buttons to select an option.
  - If room temperature is over 35°C or the 3D video is working, this is not available.
  - You can select this function through the **MENU** button.
  - Press the **BACK** button to exit the menu screen.



## High Altitude

\* High Altitude is used at environments higher than 4,000 feet.

1. Press the **MENU** button, then go to **OPTION** with the  $\wedge$ ,  $\vee$ ,  $\lt$ ,  $\gt$  buttons and press **OK** .
2. Press the  $\wedge$ ,  $\vee$  buttons to go to High Altitude and press **OK** .
3. Press the  $\lt$ ,  $\gt$  buttons to select **On** and press **OK** .
  - Press the **BACK** button to exit the menu screen.

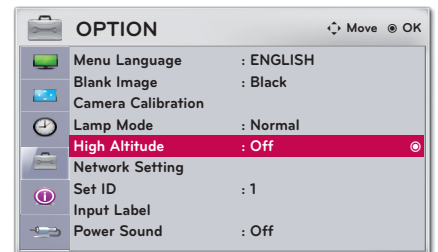

## Network Settings

< Notes >

- Use a standard LAN cable with this projector. (Cat5, Cat5E, or Cat6 with an RJ45 connector)
- Modem reconfiguration may cause network connection problems. In this case, turn off the modem and disconnect it from the projector; then turn on the modem again.
- To connect to a wireless router, a router that supports wireless connection is necessary; the wireless connection function of the corresponding router must also be activated.
- To connect to a wireless router, verify the SSID and security settings of the wireless router. Please refer to the user guide of the corresponding router regarding SSID and security settings of the wireless router.
- The projector may not work properly if network devices (wire/wireless router or hub, etc.) are incorrectly set up. Be sure to install the devices correctly by referring to their user guides before configuring network settings.
- The Ad-hoc connection method will not work properly with every computer. We recommend you use standard networking by connect devices to a router.
- The connection method may vary according to the manufacturer of the wireless router.

### <How to Connect>

Connect the LAN port of the projector to the LAN port of the PC or router using a LAN cable (Cross cable).

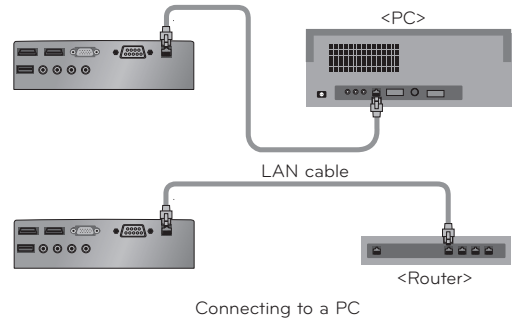

### <How to Use>

1. Press the **MENU** button, then go to **OPTION** with the  $\wedge$ ,  $\vee$ ,  $\leftarrow$ ,  $\rightarrow$  buttons and press **OK**.
2. Press the  $\wedge$ ,  $\vee$  buttons to go to **Network Setting** and press **OK**.
3. Press the  $\leftarrow$ ,  $\rightarrow$  buttons to select On for LAN option.
4. Press the  $\wedge$ ,  $\vee$  buttons to go to **IP Auto Setting** or **IP Manual Setting** and press **OK**.

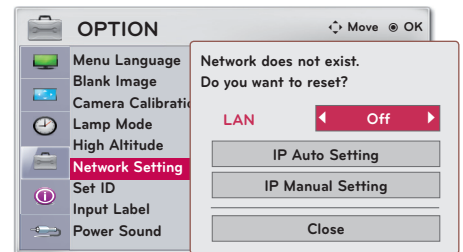

#### <IP Manual Setting>

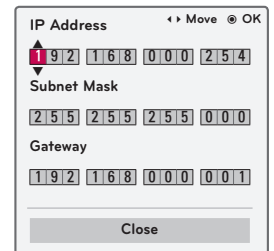

- Select **IP Auto Setting** for a server PC.
  - Select **IP Manual Setting** for an ordinary PC.
- PC Setup: Set the Internet Protocol (TCP/IP) of the PC at your own discretion.  
 Projector Setup: Set the IP Address as the same IP Address format of the PC, and select Close after entering the same gateway as the PC. Please refer to the eZ-Net Manager Guide for details of network settings.

:: Example::

	IP Address	Subnet Mask	Gateway
PC	192.168.0.10	255.255.255.0	192.168.0.1
Projector	192.168.0.254	255.255.255.0	192.168.0.1

- If Network Setting is not working, check your network status and the LAN cable connection.
  - If Network Setting is not completed, network functions may not work properly.
  - IP Auto Setting: Select this if there is a DHCP (Dynamic Host Configuration Protocol) server on the local area network (LAN) via a wired connection; the projector will automatically be allocated an IP address. It may not be possible to connect to DHCP if a firewall is installed or depending on the model of the computer.
- IP Manual Setting: Select IP Manual Setting if there is no DHCP server on the network and you want to set the IP address manually.
- Press the **BACK** button to exit the menu screen.

### Setting SET ID

\* Set ID is 1 - 99.

\* Only the saved Set ID is effective.

1. Press the **MENU** button, then go to **OPTION** with the  $\wedge$ ,  $\vee$ ,  $\lt$ ,  $\gt$  buttons and press **OK**.
2. Press the  $\wedge$ ,  $\vee$  buttons to go to **SET ID** and press **OK**.

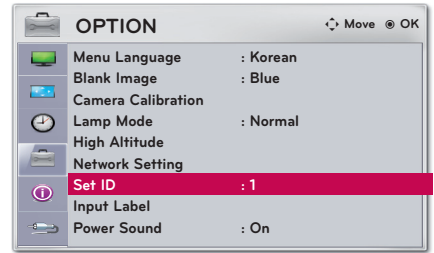

### Setting the Name of a Connected Device

\* You can set the name of an external device.

1. Press the **MENU** button, then go to Options with the  $\wedge$ ,  $\vee$ ,  $\lt$ ,  $\gt$  buttons and press **OK**.
2. Press the  $\wedge$ ,  $\vee$  buttons to go to **Input Label** and press **OK**.
3. Press the  $\wedge$ ,  $\vee$  buttons to select an input.
4. Press the  $\lt$ ,  $\gt$  buttons to select a device.
5. Press the  $\wedge$ ,  $\vee$  buttons to select **Close** and press **OK**.
  - Press the **BACK** button to exit the menu screen.

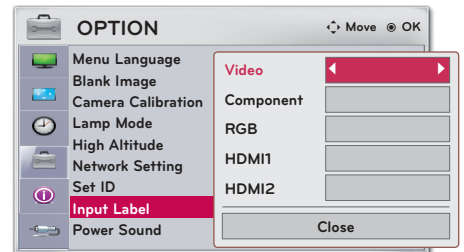

### Setting Power Sound

\* You can turn the opening sound on or off.

1. Press the **Q.MENU** button on the remote control.
2. Press the  $\lt$ ,  $\gt$  buttons to go to **Power Sound**.
3. Press the  $\wedge$ ,  $\vee$  buttons to select an option.
  - You can select this function through the **MENU** button.
  - Press the **BACK** button to exit the menu screen.

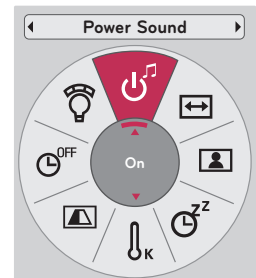

## Information Function

### Checking Projector Information

1. Press the **MENU** button, then go to **INFORMATION** with the  $\wedge$ ,  $\vee$ ,  $\lt$ ,  $\gt$  buttons and press **OK**.
2. You can check the current information of the projector.
  - Press the **BACK** button to exit the menu screen.

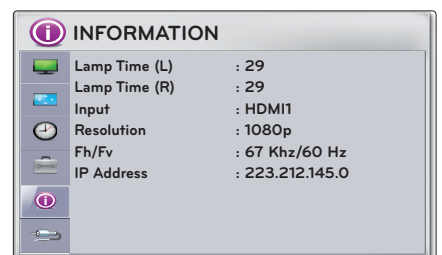

## Serial Communication Function

- \* If the projector is connected to a PC through an RS-232C cable, you can use a PC to control functions of the projector such as power On/Off or input selection, etc.
- \* You cannot use RJ45 simultaneously. For serial communication, use LAN Off in the Network Settings.

### Establishing Serial Communication

- \* Connect the RS-232C (serial connector) of the PC to the RS-232C connector on the back of the projector.
- \* You need to purchase a null modem cable to connect the RS-232C connectors as it is not provided as an accessory.

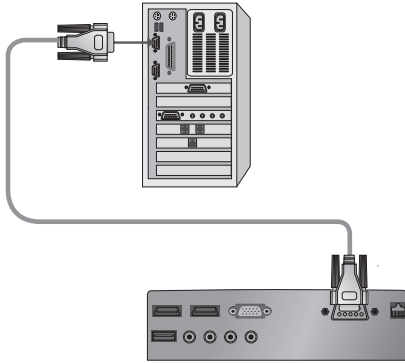

- A RS-232C null modem cable is necessary for the remote control of the projector.<See Figure 1.>

<Figure 1, RS-232 connection diagram>

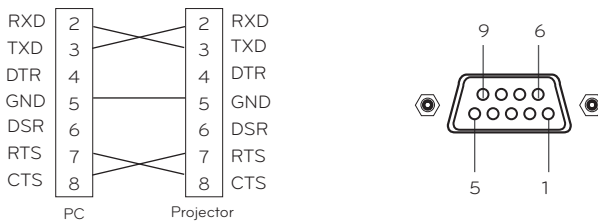

\* There is no connection to Pin 1 and Pin 9.

### Communication Parameter Setup

- Baud Rate: 9600 bps(UART)
- Data Length: 8 bit
- Parity: none
- Stop bit: 1 bit
- Flow Control: none
- Communication code: ASCII code

## Communication Protocol

### 1. Transmission

[Command1] [Command2] [ ] [Set ID] [ ] [Data] [Cr]

- \* [Command1]: The first command to control the projector (k, j, x, ASCII code, 1 Character)
- \* [Command2]: The second command to control the projector (ASCII code, 1 Character)
- \* [Set ID]: An ID used to select a set to control; the ID is allocated to each set in the Special Menu in the range of '1-99'.  
If Set ID is set to '0', you can control all the sets.
- \* [Data]: Used to send data necessary to the commands mentioned above. If it is in ASCII code, 2 characters are sent.
- \* If the data is 'FF', it means data read mode.
- \* [Cr]: Carriage Return  
It means ASCII code '0x0D'.
- \* [ ]: ASCII code character corresponding to "Space Bar" separating command, Set ID, and data.

## 2. OK Acknowledgement

[Command2] [ ] [Set ID] [ ] [OK] [Data] [x]

\* If a set receives the data successfully, it returns ACK in the above format. Here, the data will be the information from the projector indicating the current status of the projector if it is in data read mode. The projector itself will return the data from the PC if it is in data write mode.

## 3. Error Acknowledgement

[Command2] [ ] [Set ID] [ ] [NG] [Data] [x]

\* If a set receives an abnormal piece of data such as a non-supported function or there is a communication error, it returns ACK in the above format.

Data: [01]: illegal code (This command is not supported.),  
 [02]: non-supported function (This function is not working.)  
 [03]: wait and retry (Try later.)

## Command Reference List

	Command1	Command 2	Data
01. Power	k	a	0 ~ 1
02. Aspect Ratio	k	c	*
03. Screen Mute	k	d	0 ~ 1
04. Contrast	k	g	0 ~ 64
05. Brightness	k	h	0 ~ 64
06. Color	k	i	0 ~ 64
07. Tint	k	j	0 ~ 64
08. Sharpness	k	k	0 ~ 64
09. OSD Select	k	l	0 ~ 1
10. Remote Control Lock / Key Lock	k	m	0 ~ 1
11. Color Temperature	k	u	0 ~ 4 (Except. 3)
12. Black Level	n	m	0 ~ 1
13. Lamp Mode	n	p	0 ~ 1
14. Auto configuration	j	u	1
15. Input Select	x	b	*
16. Key	m	c	*
17. Picture Mode	n	S	0 ~ 7
18. 3D	x	t	Data1 : 0 ~ 3 Data2 : 0 ~ 3 Data3 : 0 ~ 1 Data4 : 0 ~ 14
19. 3D Option Control	x	v	Data1 : 0 ~ 2 Data2 : - Data1=0 : 0~1 - Data1=1 : 0~14 - Data1=2 : 0~14

**01.Power (Command:ka)**

⇒ Controls power On/Off of a set.

**Transmission**

[k] [a] [ ] [Set ID] [ ] [Data] [Cr]

Data 0 : Power Off  
1: Power On

**Ack**

[a] [ ] [Set ID] [ ] [OK] [Data] [x]

Data 0 : Power Off  
1: Power On

⇒ Gives information about power On/Off.

**Transmission**

[k] [a] [ ] [Set ID] [ ] [FF] [Cr]

**Ack**

[a] [ ] [Set ID] [ ] [OK] [Data] [x]

Data 0 : Power Off  
1: Power On

\* As with other functions, if data is transmitted as '0xFF' in the above format, the current status of each function is returned as a feedback in Ack data.

**02. Aspect Ratio(Command:kc)**

⇒ Adjusts screen size.

**Transmission**

[k] [c] [ ] [Set ID] [ ] [Data] [Cr]

Data 1 : Normal Screen (4:3) 2 : Wide Screen (16:9)  
4: Zoom 6: Set By Program 9 : Just Scan  
10-1f : Cinema Zoom 1-16

**Ack**

[c] [ ] [Set ID] [ ] [OK] [Data] [x]

Data 1 : Normal Screen (4:3) 2 : Wide Screen (16:9)  
4: Zoom 6: Set By Program 9 : Just Scan  
10-1f : Cinema Zoom 1-16

**03. Screen Mute (Command:kd)**

⇒ Controls screen Mute On/Off.

**Transmission**

[k] [d] [ ] [Set ID] [ ] [Data] [Cr]

Data 0: Screen Mute Off (video On)  
1: Screen Mute On (video Off)

**Ack**

[d] [ ] [Set ID] [ ] [OK] [Data] [x]

Data 0: Screen Mute Off (video On)  
1: Screen Mute On (video Off)

**04. Contrast (Command : kg)**

⇒ Adjusts screen brightness.

**Transmission**

[k] [g] [ ] [Set ID] [ ] [Data] [Cr]

Data Min : 0 - Max : 64

**Ack**

[g] [ ] [Set ID] [ ] [OK] [Data] [x]

Data Min : 0 - Max : 64

\* Refer to the actual data structure 1.

**05.Brightness(Command:kh)**

⇒ Adjusts screen brightness.

**Transmission**

[k] [h] [ ] [Set ID] [ ] [Data] [Cr]

Data Min : 0H - Max : 64H

**Ack**

[h] [ ] [Set ID] [ ] [OK] [Data] [x]

Data Min : 0H - Max : 64H

\* Refer to the actual data structure 1.  
(\* Transmitted in hexadecimal code)

**06.Color (Command : ki)**

⇒ Adjusts screen color. (Video / S-Video / Component)

**Transmission**

[k] [i] [ ] [Set ID] [ ] [Data] [Cr]

Data Min : 0 - Max : 64

(\* Transmitted in hexadecimal code)

**Ack**

[i] [ ] [Set ID] [ ] [OK] [Data] [x]

Data Min : 0 - Max : 64

\* Refer to the actual data structure 1.

**07.Tint (Command : kj)**

⇒ Adjusts screen color. (Video / S-Video / Component)

**Transmission**

[k] [j] [ ] [Set ID] [ ] [Data] [Cr]

Data Red : 0H - Green : 64H

(\* Transmitted in hexadecimal code)

**Ack**

[ ] [ ] [Set ID] [ ] [OK] [Data] [x]

Data Red : 0H - Green : 64H

\* Refer to the actual data structure 2.

**08 .Sharpness (Command : kk)**

⇒ Adjusts screen sharpness. (Video / S-Video / Component)

**Transmission**

[k] [k] [ ] [Set ID] [ ] [Data] [Cr]

Data Min : 0H - Max : 64H

(\* Transmitted in hexadecimal code)

**Ack**

[k] [ ] [Set ID] [ ] [OK] [Data] [x]

Data Min : 0H - Max : 64H

\* Refer to the actual data structure 1.

\* This function is used when a remote control is not being used.  
When the remote control lock is On, all the buttons on the control panel and remote control do not support the Set function.

**09 .OSD Select (Command : kl)**

⇒ Selects OSD On/Off.

**Transmission**

[k] [l] [ ] [Set ID] [ ] [Data] [Cr]

Data 0: OSD Select Mode Off

1: OSD Select Mode On

**Ack**

[l] [ ] [Set ID] [ ] [OK] [Data] [x]

Data 0: OSD Select Mode Off

1: OSD Select Mode On

**10.Remote Control Lock/Key Lock (Command: km)**

⇒ Sets the function of locking the remote control and local keypad of the remote control.

**Transmission**

[k] [m] [ ] [Set ID] [ ] [Data] [Cr]

Data 0: Lock Off

1: Lock On

**Ack**

[m] [ ] [Set ID] [ ] [OK] [Data] [x]

Data 0: Lock Off

1: Lock On

\* This function is used when the remote control is not being used. If remote control lock is On, none of the buttons of the local keypad and remote control will work.

**11.Color Temperature (ACC) (Command: ku)**

⇒ Adjusts the value of color temperature.

**Transmission**

[k] [u] [ ] [Set ID] [ ] [Data] [Cr]

Data 0: Medium 1: Cool 2: Warm 4: Natural

(\* Transmitted in hexadecimal code)

\* 3 is not used.

**Ack**

[u] [ ] [Set ID] [ ] [OK] [Data] [x]

Data 0: Medium 1: Cool 2: Warm 4: Natural

## 12. Black Level (Command: nm)

⇒ Adjusts the value of Black Level

### Transmission

[n] [m] [ ] [Set ID] [ ] [Data] [Cr]

Data 0: Low 1: High  
(\* Transmitted in hexadecimal code)

### Ack

[m] [ ] [Set ID] [ ] [OK] [Data] [x]

Data 0: Low 1: High

## 13. Lamp Mode (Command: np)

⇒ A function used to set Lamp Mode.

### Transmission

[n] [p] [ ] [Set ID] [ ] [Data] [Cr]

Data 0: Normal 1: Economic  
(\* Transmitted in hexadecimal code)

### Ack

[p] [ ] [Set ID] [ ] [OK] [Data] [x]

Data 0: Normal 1: Economic

## 14. Auto Configure (Command: ju)

⇒ Adjusts the video position by using RGB Mode and minimizing image shake.

### Transmission

[j] [u] [ ] [Set ID] [ ] [Data] [Cr]

Data 1: To set  
(\* Transmitted in hexadecimal code)

### Ack

[u] [ ] [Set ID] [ ] [OK] [Data] [x]

Data 1: To set

## 15. Input Select (Command: xb)

⇒ Select the input signal of a set.

### Transmission

[x] [b] [ ] [Set ID] [ ] [Data] [Cr]

Data 20: Video 40: Component 60: RGB  
90: HDMI1 91: HDMI2  
(\* Transmitted in hexadecimal code)

### Ack

[b] [ ] [Set ID] [ ] [OK] [Data] [x]

Data 20: Video 40: Component 60: RGB  
90: HDMI1 91: HDMI2

## 16. Key (Command: mc)

⇒ Sends a key code of the IR remote control.

### Transmission

[m] [c] [ ] [Set ID] [ ] [Data] [Cr]

Data key code \* Refer to page 44.  
(\* Transmitted in hexadecimal code)

### Ack

[c] [ ] [Set ID] [ ] [OK] [Data] [x]

Data key code

## 17. Picture Mode (Command: ns)

⇒ A function used to set Picture Mode

### Transmission

[n] [s] [ ] [Set ID] [ ] [Data] [Cr]

Data 0: Vivid 1: Standard 2: Natural  
3: Cinema 4: Sport 5: Game  
6: Expert 1 7: Expert 2  
(\* Transmitted in hexadecimal code)

### Ack

[s] [ ] [Set ID] [ ] [OK] [Data] [x]

Data 0: Vivid 1: Standard 2: Natural  
3: Cinema 4: Sport 5: Game  
6: Expert 1 7: Expert 2  
(\* Transmitted in hexadecimal code)

## &lt;Key Code&gt;

Key Name	Key Code
^	0x40
v	0x41
>	0x06
<	0x07
Power	0xAD
Input	0xEF
Menu	0x43
Back	0x28
OK	0x44
STILL	0xBC
RATIO	0x79
BLANK	0x84
PICTURE	0x4D
AUTO	0x92
Q.MENU	0x45
SLEEP	0x0E
3D	0xDC
PATTERN	0x6F
VIDEO	0x5A
COMP	0xBF
RGB	0xD5
HDMI 1	0xCE
HDMI 2	0xCC

**18. 3D (Command: xt)**

⇒ Controls 3D.

**Transmission**

[x][t][Set ID][Data1][Data2][Data3][Data4][Cr]

**Data 1 (3D Mode)**

0: 3D Mode on 1: 3D Mode off  
2: 3D to 2D 3: 2D to 3D

**Data 2 (3D Format)**

0: TOP and BOTTOM 1: Side by Side  
2: Check Board 3: Frame Sequential

**Data 3 (LR)**

0: RL 1: LR

**Data 4 (3D Depth)**

0 - 14

(\* Transmitted in hexadecimal code)

\*\*\* Note \*\*\*

⇒ Depth is available in 2D to 3D mode.

**Ack**

[t][Set ID][OK][Data1][Data2][Data3][Data4][x]

**Data 1 (3D Mode)**

0: 3D Mode on 1: 3D Mode off  
2: 3D to 2D 3: 2D to 3D

**Data 2 (3D Format)**

0: TOP and BOTTOM 1: Side by Side  
2: Check Board 3: Frame Sequential

**Data 3 (LR)**

0: RL 1: LR

**Data 4 (3D Depth)**

0 - 14

(\* Transmitted in hexadecimal code)

**19. 3D Option control (Command: xv)**

⇒ In 3D, it controls LR, Depth, and Viewpoint.

**Transmission**

[x][v][Set ID][Data1][Data2][Cr]

**Data 1**

0: LR 1: Depth 2: Viewpoint

**Data 2 :**

i) Data1=0 (LR) ⇒ 0-1  
ii) Data1=1 (Depth) ⇒ 0-14  
III) Data1=2 (Viewpoint) ⇒ 0-14

(\* Transmitted in hexadecimal code)

\*\*\* Note \*\*\*

⇒ Depth is available in 2D to 3D mode.

**Ack**

[v][Set ID][OK][Data1][Data2][x]

**Data 1**

0: LR 1: Depth 2: Viewpoint

**Data 2 :**

i) Data1=0 (LR) ⇒ 0-1  
ii) Data1=1 (Depth) ⇒ 0-14  
III) Data1=2 (Viewpoint) ⇒ 0-14

(\* Transmitted in hexadecimal code)

\*\*\* Note \*\*\*

⇒ Depth is available in 2D to 3D mode.

## Communication using Hyper Terminal

You can control multiple projectors from a single computer using the protocol.

### 1. Setting Hyper Terminal

#### 1. Specifying communication port in User Configuration



#### 2. Set to 9600

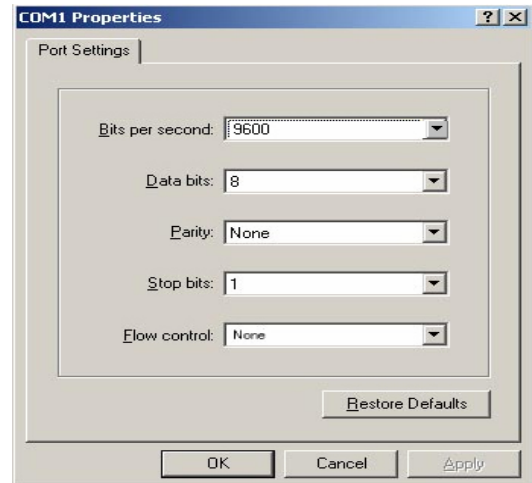

#### 3. Set to Test registration information

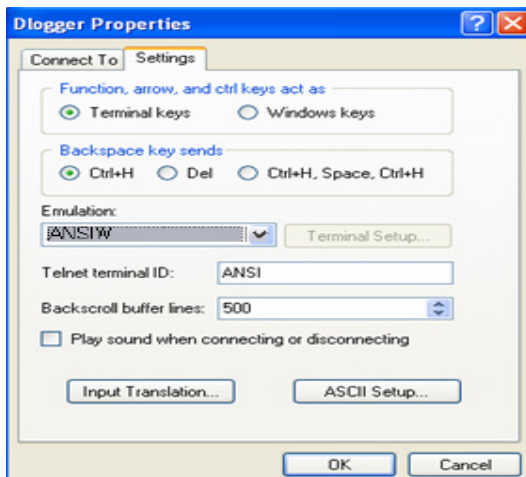

#### 4. Set to ASCII

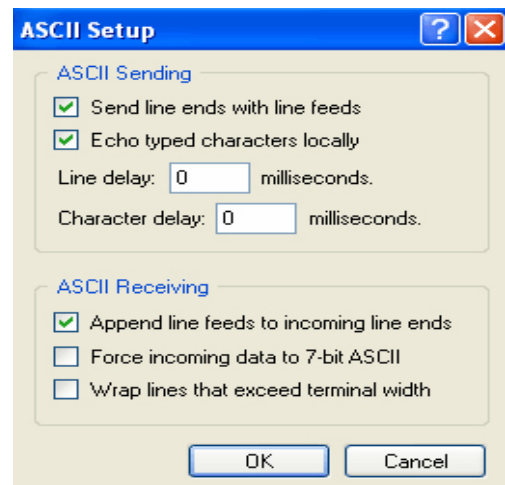

## 2. Example of entering input switching command by using Hyper Terminal.

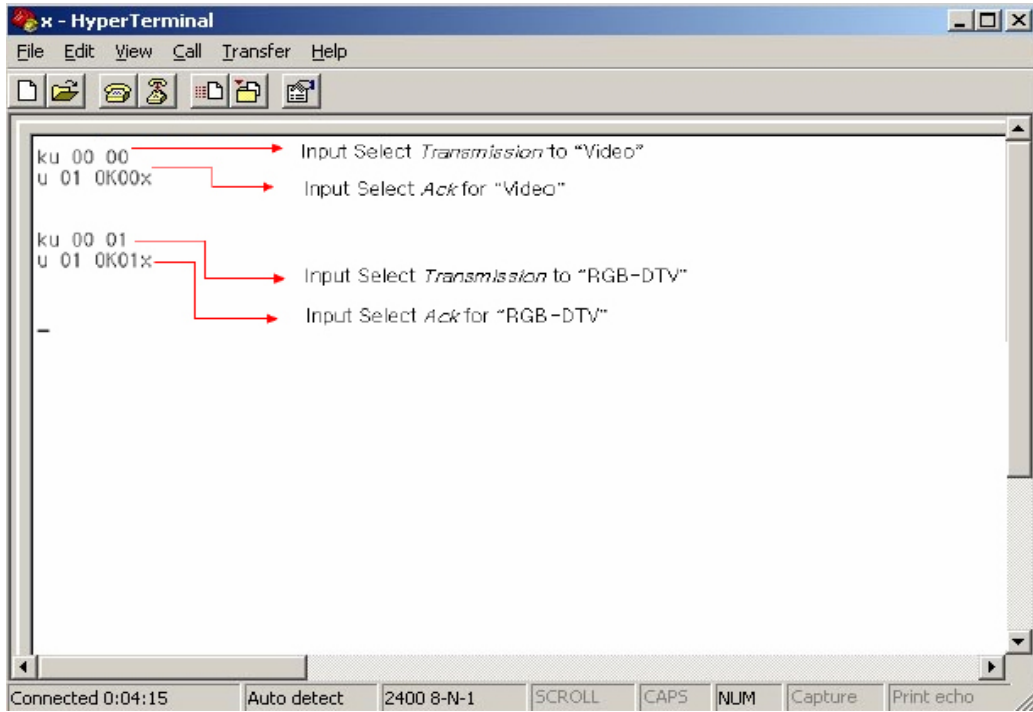

# Miscellaneous

## Supported Monitor Display

\* The following table lists the display formats supported by the projector.

Resolution	Vertical Frequency (Hz)	Horizontal Frequency (kHz)
720X400	70.080	31.469
640X480	59.940	31.469
800X600	60.310	37.879
1024X768	60.000	48.363
1152X864	60.053	54.348
1280X768	59.870	47.776
1360X768	60.015	47.712
1280X960	60.000	60.000
1280X1024	60.020	63.981
1400X1050	59.979	65.317
1680X1050	60.000	65.300
1920X1080	60.000	67.500

\* If the projector does not support the input signal, the "Invalid Format" message appears on the screen.

\* The projector supports the DDC1/2B type as a Plug & Play function. (Auto-recognition of PC monitors)

\* PC synchronization signal types supported: Separate type synchronization.

\* 1920x1080 is recommended for the best picture quality in PC mode.

\* HDMI-PC signal does not support 1920x1080 resolution.

### < DVD/DTV Input >

Signal	Component-*1	HDMI-*2
NTSC (60 Hz)	480i	○
	480p	○
	720P	○
	1080i	○
	1080p	○
PAL (50 Hz)	576i	○
	576p	○
	720P	○
	1080i	○
	1080p	○
24 / 30 Hz	1080p	○

#### \* Cable Type

1- RGB to Component **conversion**

**cable**

2- HDMI **cable**

## Maintenance

\*Clean the case, lens, suction ports and exhaust vents of the projector periodically.

If dust or stains accumulate on the projector, it may appear on the screen, or the screen may appear darker. Cleaning is therefore very important.

If replacement parts are required, contact your seller or an LG Electronics Service Center.

To clean the parts of a projector, turn off the projector and pull the plug from the power outlet.

Clean the projector more often if it is used for commercial purposes or it is used in a dusty environment.

### Cleaning the projector lens

If there is any dust or staining on the lens surface, you must clean the lens.

Use an air spray or a cleaning cloth to clean the lens.

To remove dust or stains, use an air spray or apply a small amount of cleaning agent onto a swab or soft cloth to clean the lens. Please be aware that liquid may flow into the lens if the product is sprayed directly onto the lens.

### Cleaning the projector case

To clean the projector case, first unplug the power cord.

Do not use alcohol, benzene, thinners or other chemicals which may damage the case.

### Cleaning the air vents

Check the air vents for dust or contaminants often and remove them, as it is easy for them to accumulate. If you continue to use the projector without removing these materials, the projector may not work properly due to its internal components overheating.

## Cleaning the projector filter

It is recommended to clean the filter once a month to maintain the performance of the projector. When prompted to clean the filter, take the following steps.

### <Cleaning the Top Filter>

1. Turn off the projector and unplug the power cord. Place the projector on a table or flat surface.
2. Open the filter cover by pushing the filter cover lock in the direction of the arrow as shown in the picture.
3. After separating the filter cover, remove the screw.



- 3 Take out the filter and dust off lightly. (If the filter is damaged, use a new filter which is supplied as an accessory.)
- 4 After installing the filter and filter cover, push the filter cover lock in the reverse direction of the arrow until it clicks.

### <Cleaning the Bottom Filter>

1. Turn off the projector and unplug the power cord. Place the projector on a table or flat surface.
2. Take out the filter by pulling the bottom filter in the
3. direction of the arrow as in the picture. (If the filter is damaged, use a new filter which is supplied as an accessory.)
4. Install the filter in the reverse order.

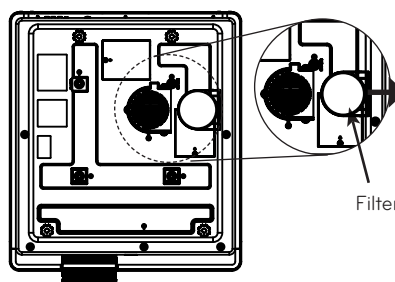

## Do not turn off the projector

### Replacing the Lamp

The lifetime of the lamp depends on the environment in which the projector is used. You can check how long the lamp has been used in the Lamp Time of the **INFORMATION** menu.

You must replace the lamp when:

- The projected image gets darker or starts to deteriorate in quality.
- The lamp indicator is magenta.
- The message "Replace the lamp" appears on the screen when turning the projector on.

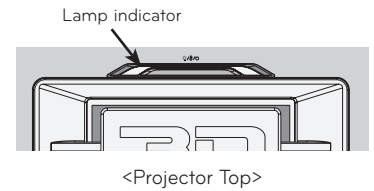

### Be careful when replacing the lamp

- Press the POWER button to turn off the power.
- If the operation indicator LED is cyan and blinking, do not disconnect the mains supply until the operation indicator LED has changed to blue as the fan is still running.
- Allow the lamp to cool down for 1 hour before replacing it.
- Replace only with the same type of lamp from an LG Electronics Service Center. Using another manufacturer's lamp may damage the projector and lamp.
- Only pull the lamp out when replacing it.
- Keep the lamp unit out of reach of children. Keep the lamp away from heat sources such as radiators, stoves etc. There is a risk of fire or burning.
- Do not expose the lamp to liquids or foreign materials. The lamp may burst.
- Do not insert any flammable or metal objects into the lamp socket after removing the lamp. This can result in electrical shock or damage the product.
- Fix the new lamp with screws securely. If it is not securely fixed, the projected image may become darker and there may be a fire risk.
- Do not touch the front glass of the new lamp or the glass of the lamp container. Picture quality and lamp lifetime may suffer.

### Purchasing a replacement lamp

Lamp model numbers are listed on page 47, "Product Specifications". Check the lamp model and then purchase it from an LG Electronics Service Center. (Using another manufacturer's lamp may damage the projector.)

### Disposing of the lamp

Dispose of the used lamp by returning it to the LG Electronics Service Center.

### Projector lamp control

#### Warning

- within the first 5 minutes of turning it on.
  - Frequent On/Off changes may reduce lamp performance.
- Do not pull out the power cord while the projector or the cooling fan are running.
  - It may reduce the lifetime of the lamp and/or cause it to burst.
- The lifetime of the projector depends on environmental and handling conditions.
- The projector uses a high pressure mercury lamp. Shock or abuse to the projector can cause the lamp to burst loudly.
- Continued use of the projector when neglecting to replace the lamp may cause the lamp to burst loudly.
- If the lamp bursts, do the following:
  - Remove the power cord immediately.
  - Allow fresh air in immediately (Ventilation).
  - Go to a nearby service center to check projector condition and replace the lamp.
  - Only an authorized service technician is allowed to disassemble the projector.

## Replacing the lamp

1. Turn off the projector and unplug the power cord. Place the projector on a table or flat surface. (Allow the lamp to cool down for 1 hour before removing the used lamp from the projector because it is very hot.)
2. Unscrew the screws from the lamp cover using a screwdriver. After pulling out the screws, lift off the lamp cover.

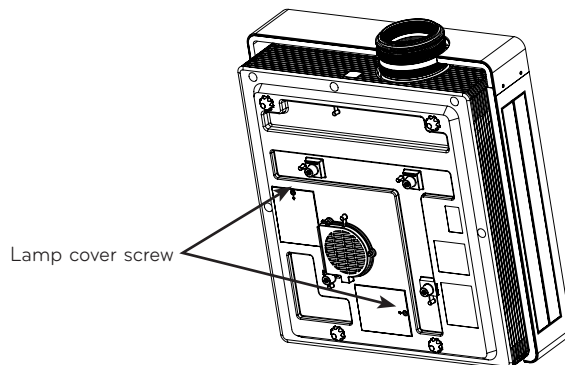

3. After lifting the lamp cover off, remove the two retaining screws which hold the lamp.

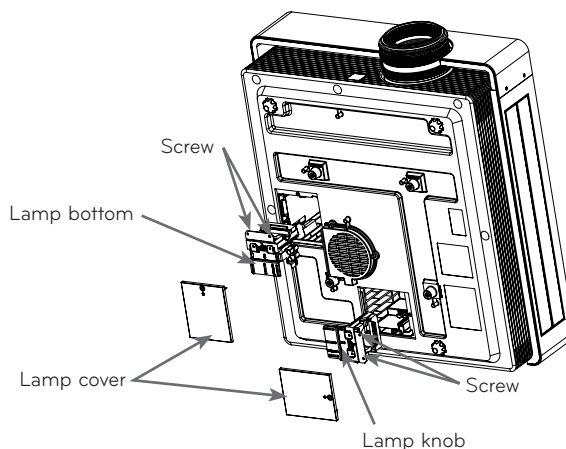

4. Pull out the lamp knob from the hitch.
5. Hold the lamp knob and pull it out slowly to remove the lamp case. Insert the new lamp gently into the correct position. Push the lamp bottom to check if it is correctly installed.
6. Tighten the screws you removed in step 3. (Make sure they are fixed firmly.)
7. Close the lamp cover and install the screws from step 2 to install the cover. (If the power is switched on while the lamp cover is open, the lamp warning indicator will be blink red and the projector will not be turned on.)

### Note!

Make sure to use the same type of lamp for replacement.

If the lamp cover is not installed correctly, the projector will not be turned on. In this case, check if the lamp is installed correctly before contacting LG Electronics Service Center.

## Troubleshooting

Please check the following when there is a problem with the projector before contacting LG Electronics Service Center.

Symptom	Checkpoint and Solution
Q. I cannot see a video on the screen.	<p>A. Check if the power light is turned on or the lens cap is closed.</p> <p>In addition, check if the cables are connected correctly according to the description in this manual.</p> <p>A wrong input signal may have been selected. Select another input signal by pressing the input selection button of the remote control or control panel.</p>
Q. "No signal" is displayed on the screen.	<p>A. A video device which is not connected to the projector has been selected, there is no signal from a computer or video device, or a connector has been incorrectly connected. Check the connection between the projector and the video device and also check if the input signal from the video device has been selected correctly.</p>
Q. "This mode is not supported (or 'No supported mode')" is displayed.	<p>A. The projector cannot interpret the computer signal.</p> <p>Check supported monitor display format.</p>
Q. Part of the video or the entire video is blurred or there is no focus.	<p>A. Adjust the focus and position of the video.</p> <p>A. Adjust video settings.</p> <p>A. There may be dust or stains on the lens. Clean the lens according to the description in the Maintenance section.</p>
Q. Video colors are abnormal.	<p>A. It is necessary to adjust color balance. Adjust Color in Video Setting.</p>
Q. There is no screen output for HDMI connection.	<p>A. Check if the HDMI cable is a high-speed HDMI® cable.</p> <p>If it is not a high-speed HDMI® cable, the screen may flicker or not display anything.</p>
Q. 3D video is displayed abnormally.	<p>A. Select another 3D video.</p> <p>A. Press the "3D OPTION" button on the remote control and go to the 3D Configuration menu. Select better 3D video when changing the "3D Configuration".</p> <p>A. Check if the screen is 3D-compatible.</p>

## Product Specifications

MODELS	CF3DA (CF3DA-JS)
Resolution	1920 (H) x 1080 (V) pixels
Aspect ratio	16:9 (H:V)
Panel size (mm)	15.4
Projection distance (Video size)	Wide: 0.88 m - 9.08 m (76.2 cm - 762.0 cm) Tele: 1.14 m - 11.8 m (76.2 cm - 762.0 cm)
Ratio of upward projection	100 %
Working range of the remote control	12 m
Video input	NTSC/PAL/SECAM/NTSC4.43/PAL-M/PAL-N/PAL-60
POWER	AC 110 V - 240 V - 50/60 Hz, 5.5 A
Height (mm)	190
Width (mm)	501
Length (mm)	560
Weight (kg)	21.1

### Operation environment

#### Temperature

Operating temperature: 0°C to 35°C  
Storage temperature: -20°C to 60°C

#### Humidity

Operating humidity: 0% to 80% Relative humidity  
Storage humidity: 0% to 85% Relative humidity

#### Altitude

Operating altitude: 0 m ~ 2500 m

### Projector lamp

#### Lamp model name

AJ-LCF3

#### Power consumption of lamp

220 W (2EA)

## Open Source software Information

The following GPL/LGPL/MPL execution files and libraries in this projector comply with the GPL 2.0/LGPL 2.1/MPL 1.1 license agreement.

### GPL execution files:

Linux kernel 2.6, busybox, lzo, u-boot

### LGPL library:

uClibc

### MPL library:

nanox

You can ask LG Electronics for the source codes at the e-mail address below. We will send you a CD-ROM if you pay for expenses such as media cost or delivery, etc.: **opensource@lge.com**

This is effective for 3 years from the purchase date of the projector.

You can download the original copies of the GPL, LGPL, or MPL licenses at

**<http://www.gnu.org/licenses/>** or **<http://www.mozilla.org/MPL/>**.

In addition, you can check the translations of the GPL and LGPL at

**<http://www.gnu.org/licenses/old-licenses/gpl-2.0-translations.html>**,

**<http://www.gnu.org/licenses/old-licenses/lgpl-2.1-translations.html>**.

Some software in the projector complies with the following copyright.

- ▶ jpeg: Independent JPEG Group, copyright © 1991 – 1998, Thomas G. Lane.
- ▶ libpng: copyright © 2004 Glenn Randers-Pehrson
- ▶ tinymce: copyright © 2000-2006 Lee Thomason
- ▶ zlib: copyright © 1995-2002 Jean-loup Gailly and Mark Adler.

All rights reserved.

Permission is hereby granted, free of charge, to any person obtaining a copy of this software and associated documentation files (the "Software"), to deal in the Software without restriction, including without limitation the rights to use, copy, modify, merge, publish, distribute, sublicense, and/or sell copies of the Software, and to permit persons to whom the Software is furnished to do so, subject to the following conditions:

THE SOFTWARE IS PROVIDED "AS IS", WITHOUT WARRANTY OF ANY KIND, EXPRESS OR IMPLIED, INCLUDING BUT NOT LIMITED TO THE WARRANTIES OF MERCHANTABILITY, FITNESS FOR A PARTICULAR PURPOSE AND NONINFRINGEMENT. IN NO EVENT SHALL THE AUTHORS OR COPYRIGHT HOLDERS BE LIABLE FOR ANY CLAIM, DAMAGES OR OTHER LIABILITY, WHETHER IN AN ACTION OF CONTRACT, TORT OR OTHERWISE, ARISING FROM, OUT OF OR IN CONNECTION WITH THE SOFTWARE OR THE USE OR OTHER DEALINGS IN THE SOFTWARE.



The model and serial number of the projector is located on the back or one side of the projector. Record it below should you ever need service.

**MODEL** \_\_\_\_\_

**SERIAL** \_\_\_\_\_