



PCS500R Pro:Centric[®] Server

Installation & Setup Guide Warranty

www.lg.com

Copyright © 2021 LG Electronics Inc. All Rights Reserved.



* S A C 3 8 5 2 2 5 0 1 *

(2110-REV00)

Table of Contents

4 IMPORTANT SAFETY INSTRUCTIONS

8 PCS500R Product Description

8 Features

9 Setup Information

9 PCS500R

9 Video Channel Assignments for RF Output (QAM-B)

10 Video Channel Assignments for RF Output (DVB-C)

10 Video Channel Assignments for RF Output (ISDB-T)

11 Video Channel Assignments for IP Output

12 Rear and Front Panel Overviews

12 PCS500R Rear View

13 PCS500R Front View

14 Rack Installation

14 Typical Rack Installation

15 Rack-mount Considerations

16 System Setup

16 Typical Setup Diagram for PCS500R with RF Output

17 Typical Setup Diagram for PCS500R with IP Output

18 VPN Network Connections Overview

19 Setting Up the Pro:Centric Network

23 PCS500R Configuration Options

23 Network and Communication Setup

24 Log In to the PCS500R and Access the Main Menu

25 View System Information

26 Modify Network Settings

30 Modify the Server Host Name (via TUI)

31 Modify the Server Host Name (via CLI)

32 Set the Time Zone

33 Set the Date and Time

34 Change the Login Password

34 Change the Portal Application

36 Monitor the System

37 Send Ping Commands to Network Hosts

38 Update the Pro:Centric Application

38 Update the VPN Setup

39 Shut Down the System

39 Reset the System

40 Reinstall the Factory Configuration

40 Exit the Current Session

41 Troubleshooting

- 41 PCS500R Setup
- 42 PCS500R Communication

43 Specifications

45 Reference: Network Communication Port Protocols

46 Document Revision History / Notes

46 Open Source Software Notice

47 Regulatory

- 47 FCC Notice
- 47 FCC Radio Frequency Interference Requirements (for UNII devices)
- 47 FCC RF Radiation Exposure Statement
- 48 Industry Canada Statement
- 48 IC Radiation Exposure Statement
- 48 RSS-247 Requirement
- 49 WARNING!
- 49 Symbols

50 LG PCS500R Pro:Centric Server Warranty

IMPORTANT SAFETY INSTRUCTIONS

For Customer Support/Service, please call: 1-888-865-3026

The latest product information and documentation is available online at: www.lg.com/us/business



WARNING:

TO REDUCE THE RISK OF ELECTRIC SHOCK DO NOT REMOVE COVER (OR BACK). NO USER-SERVICEABLE PARTS INSIDE. REFER TO QUALIFIED SERVICE PERSONNEL.

 The lightning flash with arrowhead symbol, within an equilateral triangle, is intended to alert the user to the presence of uninsulated "dangerous voltage" within the product's enclosure that may be of sufficient magnitude to constitute a risk of electric shock to persons.

 The exclamation point within an equilateral triangle is intended to alert the user to the presence of important operating and maintenance (servicing) instructions in the literature accompanying the appliance.

WARNING:

To prevent fire or shock hazards, do not expose this product to rain or moisture.

Apparatus shall not be exposed to dripping or splashing and no objects filled with liquids, such as vases, shall be placed on the apparatus.

L'appareil ne doit pas être exposé à des égouttements d'eau ou des éclaboussures et de plus qu'aucun objet rempli de liquide tel que des vases ne doit être placé sur l'appareil.

CAUTION:

Do not attempt to modify this product in any way without written authorization from LG Electronics U.S.A., Inc. Unauthorized modification could void the user's authority to operate this product.

COMPLIANCE:

The responsible party for this product's compliance is: LG Electronics U.S.A., Inc.
2000 Millbrook Drive, Lincolnshire, IL 60069, USA • Phone: 1-847-941-8000

Marketed and Distributed in the United States by LG Electronics U.S.A., Inc.
2000 Millbrook Drive, Lincolnshire, IL 60069
Copyright © 2021 LG Electronics Inc. All Rights Reserved.

- Read these instructions.
- Keep these instructions.
- Heed all warnings.
- Follow all instructions.
- Do not use this apparatus near water.
- Clean only with dry cloth.
- Do not block any ventilation openings. Install in accordance with the manufacturer's instructions.
- Do not install near any heat sources, such as radiators, heat registers, stoves, or other apparatus (including amplifiers) that produce heat.
- Do not defeat the safety purpose of the polarized or grounding-type plug. A polarized plug has two blades with one wider than the other. A grounding-type plug has two blades and a third grounding prong. The wide blade or the third prong are provided for your safety. If the provided plug does not fit into your outlet, consult an electrician for replacement of the obsolete outlet.
- Protect the power cord from being walked on or pinched, particularly at plugs, convenience receptacles, and the point where it exits from the apparatus.
- Only use attachments/accessories specified by the manufacturer.
- Use only with the cart, stand, tripod, bracket, or table specified by the manufacturer or sold with the apparatus. When a cart is used, use caution when moving the cart/apparatus combination in order to avoid injury from tip-over.
- Refer all servicing to qualified service personnel. Servicing is required when the apparatus has been damaged in any way, such as power-supply cord or plug is damaged, liquid has been spilled or objects have fallen into the apparatus, the apparatus has been exposed to rain or moisture, does not operate normally, or has been dropped.

- **Power Sources**

This product should be operated only from the type of power source indicated on the marking label. If you are not sure of the type of power supply to your INSTALLATION, consult your product dealer or local power company.

- **Overloading**

Do not overload wall power outlets and extension cords as this can result in a risk of fire or electric shock.

- **Disconnect Device**

The AC mains plug is used as the disconnect device. The disconnect device must remain readily operable.

- **Object and Liquid Entry**

Never push objects of any kind into this product through openings as they may touch dangerous voltage points or short-out parts that could result in a fire or electric shock. Never spill liquid of any kind on the product. Do not use liquid cleaners or aerosol cleaners.

- **Outdoor Use**



Warning: To prevent fire or shock hazards, do not expose this product to rain or moisture.

- **Wet Location**

Do not use this product near water or moisture or in an area, such as a basement, that might become flooded. The apparatus shall not be exposed to dripping or splashing and no objects filled with liquids, such as vases, shall be placed on the apparatus.

- **Test Equipment**

In some cases, LG has supplied or recommended the use of test equipment and devices for the setup and testing of the equipment. The operation and maintenance of test equipment is described in their associated instruction manuals. Please refer to these manuals for explicit instructions regarding the safe use and handling of the equipment.

- **Damage Requiring Service**

Unplug this product from the wall power outlet and refer servicing to qualified service personnel under the following conditions:

- If the power-supply cord or plug is damaged.
- If liquid has been spilled, or objects have fallen into the product.
- If the product has been exposed to rain or water.
- If the product does not operate normally by following the operating instructions. Adjust only those controls that are covered by the operating instructions, as an improper adjustment of other controls may result in damage and will often require extensive work by a qualified technician to restore the product to its normal operation.
- If the product has been dropped or the cabinet has been damaged.
- If the product exhibits a distinct change in performance.



Caution: Refer all servicing to qualified service personnel.

- **Serviceing**



Caution: These servicing instructions are for use by qualified service personnel only. To reduce the risk of electrical shock, do not perform any servicing other than that described in the operating instructions unless you are qualified to do so.

- **Replacement Parts**

When replacement parts are required, be sure the service technician uses replacement parts specified by the manufacturer or that have the same characteristics as the original parts. Unauthorized substitutions may result in fire, electric shock, or other hazards.

- **Safety Check**

Upon completion of any service or repairs to this product, ask the service technician to perform safety checks to determine that the product is in proper operating condition.

- **Handling Notice**



Caution: Only qualified service personnel should handle and install this unit. A series of screws with lock washers are used to secure the top and bottom covers of the unit. Use caution when handling the unit as the lock washers may have rough edges. Do NOT run your fingers over the top and bottom covers of the unit.

- **PCS500R Rack Installation (also see pages 14 to 15)**

- Wear a properly grounded, antistatic wrist strap to avoid causing electrostatic (ESD) damage to the PCS500R.
- Carefully slide the PCS500R into a standard 19-inch equipment rack.
- When mounting in the rack, make sure to use the appropriate hardware. ALL FOUR MOUNTING SCREWS MUST BE USED.
- This equipment is not designed to support other devices. Do NOT stack other equipment on the top of the PCS500R.
- Rear cabling must be dressed and supported so that the weight of the cabling is not a strain on the PCS500R connectors.
- MOUNTING OF THE EQUIPMENT IN THE RACK SHOULD BE SUCH THAT A HAZARDOUS CONDITION IS NOT ACHIEVED DUE TO UNEVEN MECHANICAL LOADING.

Rack-mount Considerations

- **Elevated Operating Ambient**

If installed in a closed or multi-unit rack assembly, the operating ambient temperature of the rack environment may be greater than room ambient. Therefore, consideration should be given to installing the equipment in an environment compatible with the maximum ambient temperature (T_{ma}) specified by the manufacturer (see Specifications information in this document).

- **Reduced Air Flow**

Installation of the equipment in a rack should be such that the amount of air flow required for safe operation of the equipment is not compromised. To ventilate the system normally and avoid overheating, leave at least 2.5 cm (1 inch) on each side (including top and bottom) of the PCS500R. Do NOT stack other equipment on the top of the PCS500R. Also, ensure that the unit's AC power adapter is never stacked or bundled with other AC power adapters. Each adapter should have adequate ventilation and should be isolated from other heat sources.

- **Circuit Overloading**

Consideration should be given to the connection of the equipment to the supply circuit and the effect that overloading of the circuits might have on overcurrent protection and supply wiring.

- **Reliable Earthing**

Maintain reliable earthing of rack-mounted equipment. Particular attention should be given to supply connections other than direct connections to the branch circuit (e.g., use of power strips).

- **Mains Outlet Earthing**

The apparatus with Class I construction must be connected to a mains socket outlet with a protective earthing connection.

Notes

- Design and specifications subject to change without prior notice.
- This document provides examples of typical command line interface and text-based user interface (TUI) displays. Your displays may vary from those shown in this document.

PCS500R Product Description

The LG PCS500R Pro:Centric® server is a stand-alone, remotely-controlled processor and controller for the Pro:Centric system. The server enables you to create and remotely manage portal and application content for LG TVs, using either the Pro:Centric Java or Pro:Centric Direct HTML application.

Features

- Supports the Pro:Centric Java or Pro:Centric Direct HTML application
- Two output options: RF or IP
 - RF output: QAM-B (6 MHz), DVB-C (6 MHz, 7 MHz, or 8 MHz), and ISDB-T (6 MHz) modulations are supported. The PCS500R generates one 256-QAM or 64-QAM RF channel for GEM/site data
 - IP output: The PCS500R generates two multicast streams for GEM/site data.
- Customer may work with content provider to create Pro:Idiom® encrypted content for RF or IP video payout channels
 - QAM-B and DVB-C RF output: In addition to the GEM/site data channel, the PCS500R generates up to seven RF channels for video payout. Each of these channels supports either two or three program streams multiplexed on each channel. This capability provides output of up to 21 programs of video content.
 - ISDB-T RF output: In addition to the GEM/site data channel, the PCS500R generates up to one (Java application) or two (HTML application) RF channels for video payout. Each of these channels supports either two or three program streams multiplexed on each channel. This capability provides output of up to three (Java application) or six (HTML application) programs of video content.
 - IP output: In addition to two multicast streams for GEM/site data, the PCS500R generates 21 multicast streams for video payout. Each data stream supports one program. This capability provides output of up to 21 programs of video content.
- Provides remote management capability over Ethernet
- Small, lightweight chassis
- 19-inch rack-mountable
- 1U height profile to minimize rack space usage

An Internet browser-based Admin Client graphical user interface (GUI), provided for system integrator (SI) partners and lodging/institution administrators, facilitates support and maintenance of the Pro:Centric system. The Admin Client enables users to remotely manage system backups, output configuration, software updates, portal/information section content, TV configuration settings, etc.

Setup Information

Check the following items before you begin the PCS500R installation and setup procedures.

Note: Once the PCS500R hardware and software is installed and the initial setup completed, output parameters are configured in the appropriate Pro:Centric Admin Client. Along with this document, it is recommended that you have readily available a copy of either the *Pro:Centric Server Admin Client User Guide* (for the Java application) or the *Pro:Centric Direct Admin Client User Guide* (for the HTML application), as applicable.

PCS500R

- Unpack the PCS500R Pro:Centric server unit and all accessories.

PCS500R Accessories: AC Power Cord and Adapter

- Select the location for mounting the PCS500R. Ensure adequate ventilation is available.
- Obtain the necessary attachment hardware to mount the PCS500R chassis in its targeted location.
- Plan and install the necessary cabling and network (Ethernet) and AC power access for the PCS500R. You also will need the following to connect a PC directly to the PCS500R for system setup purposes: FTDI TTL-USB cable (P/N TTL-232R-5V-AJ).

Video Channel Assignments for RF Output (QAM-B)

Each input program is limited to one-half or one-third of the output channel bitrates (Mbps), which in turn are dependent on the modulation format. 256-QAM modulation supports up to 38.8 Mbps per channel, and 64-QAM modulation supports up to 26.97 Mbps per channel.

- Create a channel assignment plan for the installation site, or modify an existing plan to incorporate the RF output of the PCS500R. Ensure that up to eight contiguous CATV broadcast channels are allocated for the PCS500R RF output. The PCS500R uses a 256-QAM or 64-QAM modulation format, thereby occupying approximately 48 MHz of frequency spectrum.

The RF start channel is user-assigned during system setup (in the Admin Client), and the remaining channels (up to seven) are then automatically assigned per EIA-542 STD CATV frequency allocation standards or also user-assigned, depending on channel selections in the Admin Client.

Note for contiguous channel allocation: if the RF start channel assignment is channel 2, the seven remaining channels will be 3, 4, 5, 6, 95, 96, and 97. Refer to EIA-542 STD CATV frequency allocation tables for further information as required.

The highest available RF channel number for the PCS500R is 135. Thus, to allocate all eight channels available for PCS500R RF output, the RF start channel must be set no higher than 128.

- Find a location on the frequency spectrum that is free of existing noise.

Video Channel Assignments for RF Output (DVB-C)

Each input program is limited to one-half or one-third of the output channel bitrates (Mbps), which in turn are dependent on the modulation format. 256-QAM modulation supports up to 37.27 Mbps (6 MHz bandwidth), 45.05 Mbps (7 MHz bandwidth) or 50.87 Mbps (8 MHz bandwidth) per channel, and 64-QAM modulation supports up to 27.95 Mbps (6 MHz bandwidth), 33.79 Mbps (7 MHz bandwidth) or 38.15 Mbps (8 MHz bandwidth) per channel.

- Create a channel assignment plan for the installation site, or modify an existing plan to incorporate the RF output of the PCS500R. Ensure that up to eight contiguous CATV channel frequencies are allocated for the PCS500R RF output. The PCS500R uses a 256-QAM or 64-QAM modulation format, thereby occupying approximately 48 MHz, 56 MHz, or 64 MHz (depending on channel bandwidth) of frequency spectrum. The RF start channel frequency is user-assigned, in KHz, during system setup (in the Admin Client), and the remaining channel frequencies (up to seven) are then automatically assigned in accordance with the specified bandwidth. For example, if the RF start channel frequency assignment is 57000 KHz with a 7 MHz bandwidth, the seven remaining channel frequencies will be 64000 KHz, 71000 KHz, 78000 KHz, 85000 KHz, 92000 KHz, 99000 KHz, and 106000 KHz.

The highest available RF channel frequency for the PCS500R is 861000 KHz.

- Find a location on the frequency spectrum that is free of existing noise.

Video Channel Assignments for RF Output (ISDB-T)

Each input program is limited to one-half or one-third of the output channel bitrates (Mbps). ISDB-T modulation supports up to 23.23 Mbps (6 MHz bandwidth) per channel.

- Create a channel assignment plan for the installation site, or modify an existing plan to incorporate the RF output of the PCS500R. Ensure that up to two (Java application) or three (HTML application) contiguous CATV broadcast channels are allocated for the PCS500R RF output. The PCS500R occupies up to 18 MHz of frequency spectrum.

The RF start channel is user-assigned during system setup (in the Admin Client), and the remaining channels (up to one for the Java application or two for the HTML application) are then automatically assigned in accordance with the 6 MHz bandwidth. For example, if the RF start channel assignment is channel 7 on a server configured for the HTML application, the two remaining channels will be 8 and 9.

The data channel number must be between 7 and 69. Thus, for example, to allocate all three channels available for PCS500R RF output with the HTML application, the RF start channel must be set no higher than 67.

Note: The Pro:Centric server cannot generate channels 13 and 14 simultaneously. If you intend to configure more than one channel, set the data channel number from 7 to 12 (two channels) or 7 to 11 (three channels) or from 14 to 68.

- Find a location on the frequency spectrum that is free of existing noise.

Video Channel Assignments for IP Output

Each IP stream is limited to 19.4 Mbps.

- The PCS500R outputs IPv4 multicast streams. Ensure the institution's IP network and room receivers support IPv4 multicast and that the network is capable of selectively routing multicast traffic. Refer to vendor equipment documentation for further information.

- Create a channel assignment plan for the installation site, or modify an existing plan to incorporate the IP output of the PCS500R. Ensure that up to 23 unused and unreserved IPv4 multicast addresses, within the designated range 224.0.0.0 to 239.255.255.255, are allocated for the PCS500R IP output.

The IP start channel is user-assigned in the Admin Client, and the remaining channel assignments are then automatically incremented. For example, if the IP start channel assignment is 227.0.0.40, the remaining channels will be 227.0.0.41, 227.0.0.42, etc. Since the first two streams are reserved for site data, the first video content channel in this scenario will be 227.0.0.42.

- Reserve one User Datagram Protocol (UDP) port for the multicast data streams. You can use the system default (1234) or another unassigned port number, for example, 50000, 50001, etc. The port must avoid conflict with other protocols in use.

Note: Refer to the IANA IPv4 Multicast Address Space Registry and/or the IANA Service Name and Transport Protocol Port Number Registry for further IP address/port information as required.

Rear and Front Panel Overviews

ENGLISH

PCS500R Rear View

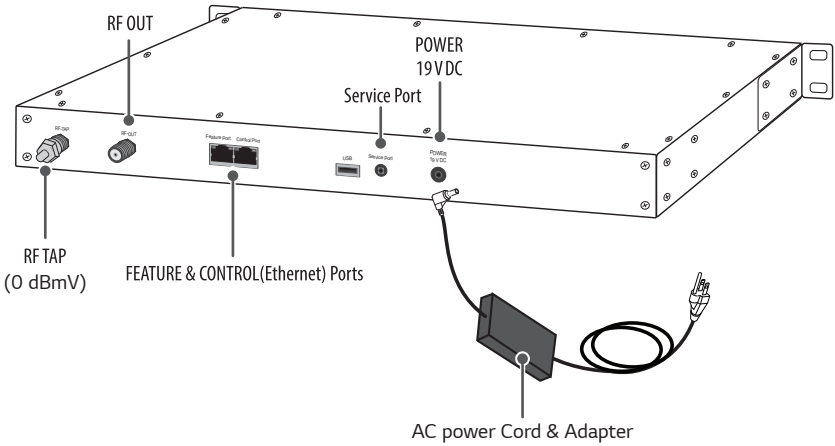

- **Disconnect Device**
The AC mains plug is used as the disconnect device. The disconnect device must remain readily operable.
- **RF TAP Connector**
Reserved for service technician use only. When not in use, this connector must remain terminated with attached terminator accessory.

PCS500R Front View

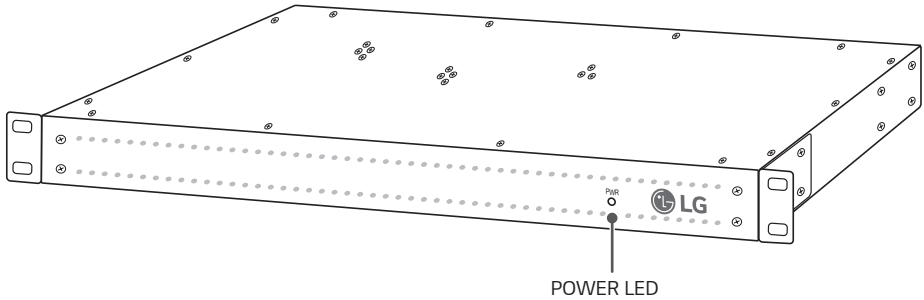

- **Ventilation**

Air flow must not be obstructed. To ventilate the system normally and avoid overheating, leave at least 2.5 cm (1 inch) on each side (including top and bottom) of the PCS500R. Do NOT stack other equipment on the top of the PCS500R.

- **Screws with Lock Washers**

Only qualified service personnel should handle and install the PCS500R. A series of screws with lock washers are used to secure the top and bottom covers of the PCS500R. Use caution when handling the unit as the lock washers may have rough edges. Do NOT run your fingers over the top and bottom covers of the unit.

Rack Installation

Typical Rack Installation

- 1 To avoid causing electrostatic (ESD) damage to the PCS500R during installation, attach an antistatic wrist strap to a properly grounded rack/object and put it on.
- 2 (Optional) As shipped, the PCS500R mounting brackets are attached flush with the front of the unit (see diagram a). If desired, the mounting brackets may be detached from the unit and reattached, for example, so that they are flush with the rear of the unit (see diagram b). If you wish to change the location/orientation of the mounting brackets, carefully remove each of the four (M4 x 10 mm) screws and attendant washers (one flat and one lock washer per screw) holding each bracket in place. Then, use the same screws and washers to reattach the mounting brackets in the desired location.
- 3 Carefully slide the chassis into a standard 48.2 cm (19 inches) equipment rack.
- 4 Use all four mounting screws to secure the chassis to the rack.

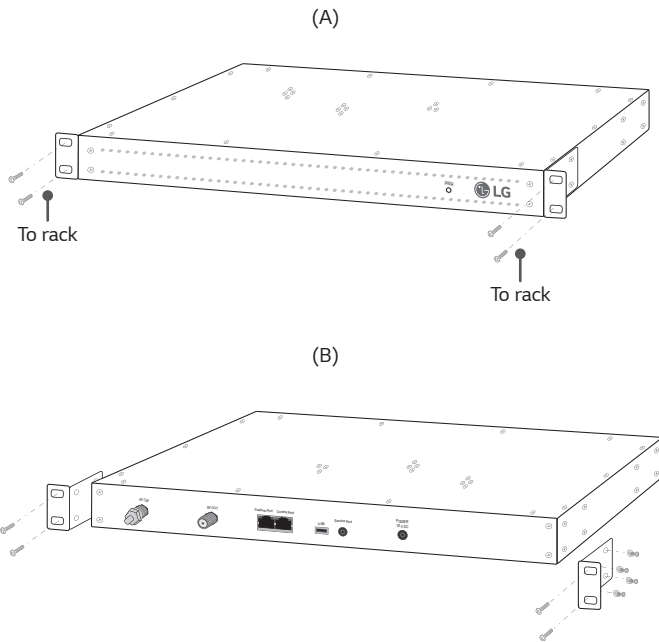

Use flat washer and lock washer with each M4 x 10 mm mounting bracket screw.

Front View of Rack Cabinet

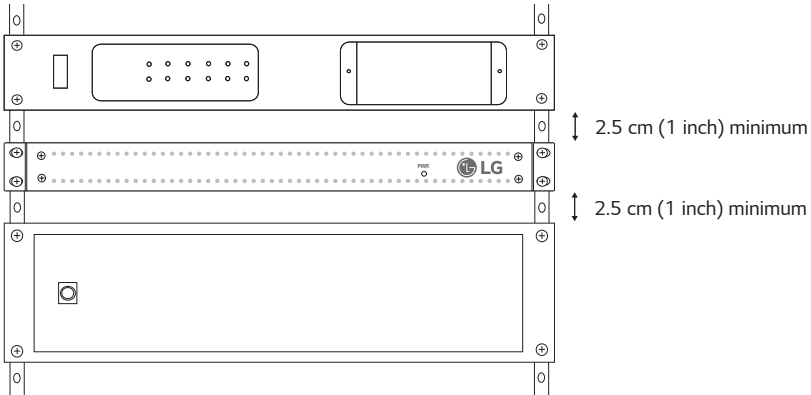

Rack-mount Considerations

A. Elevated Operating Ambient

If installed in a closed or multi-unit rack assembly, the operating ambient temperature of the rack environment may be greater than room ambient. Therefore, consideration should be given to installing the equipment in an environment compatible with the maximum ambient temperature (T_{ma}) specified by the manufacturer (see Specifications information in this document).

B. Reduced Air Flow

Installation of the equipment in a rack should be such that the amount of air flow required for safe operation of the equipment is not compromised. To ventilate the system normally and avoid overheating, leave at least 2.5 cm (1 inch) on each side (including top and bottom) of the PCS500R. Do NOT stack other equipment on the top of the PCS500R unit. Also, ensure that the unit's AC power adapter is never stacked or bundled with other AC power adapters. Each adapter should have adequate ventilation and should be isolated from other heat sources.

C. Circuit Overloading

Consideration should be given to the connection of the equipment to the supply circuit and the effect that overloading of the circuits might have on overcurrent protection and supply wiring.

D. Reliable Earthing

Maintain reliable earthing of rack-mounted equipment. Particular attention should be given to supply connections other than direct connections to the branch circuit (e.g., use of power strips).

E. Mains Outlet Earthing

The apparatus with Class I construction must be connected to a mains socket outlet with a protective earthing connection.

System Setup

Refer to the following diagrams, and complete the system installation as described on pages 19 to 22.



Caution: Do not make system connections until instructed to do so during the system installation procedure. In some instances, configuration steps must be performed before physical connections are made.

Typical Setup Diagram for PCS500R with RF Output

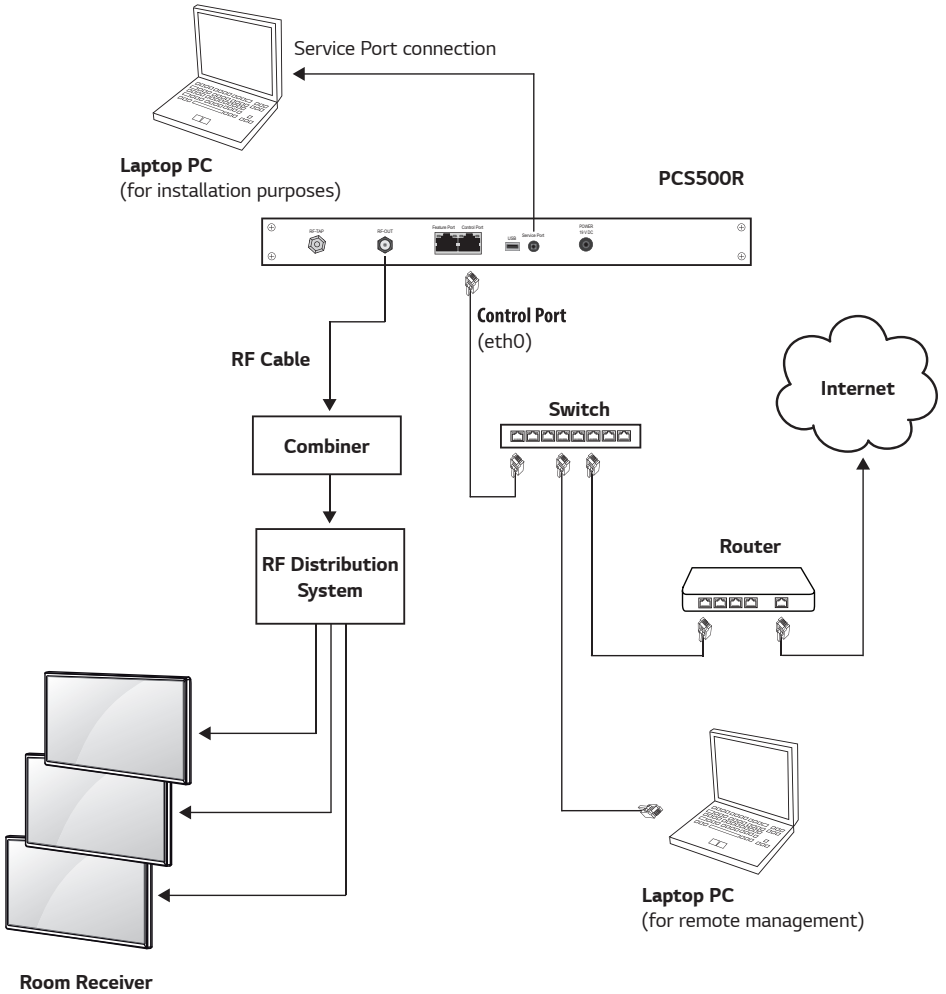

Typical Setup Diagram for PCS500R with IP Output

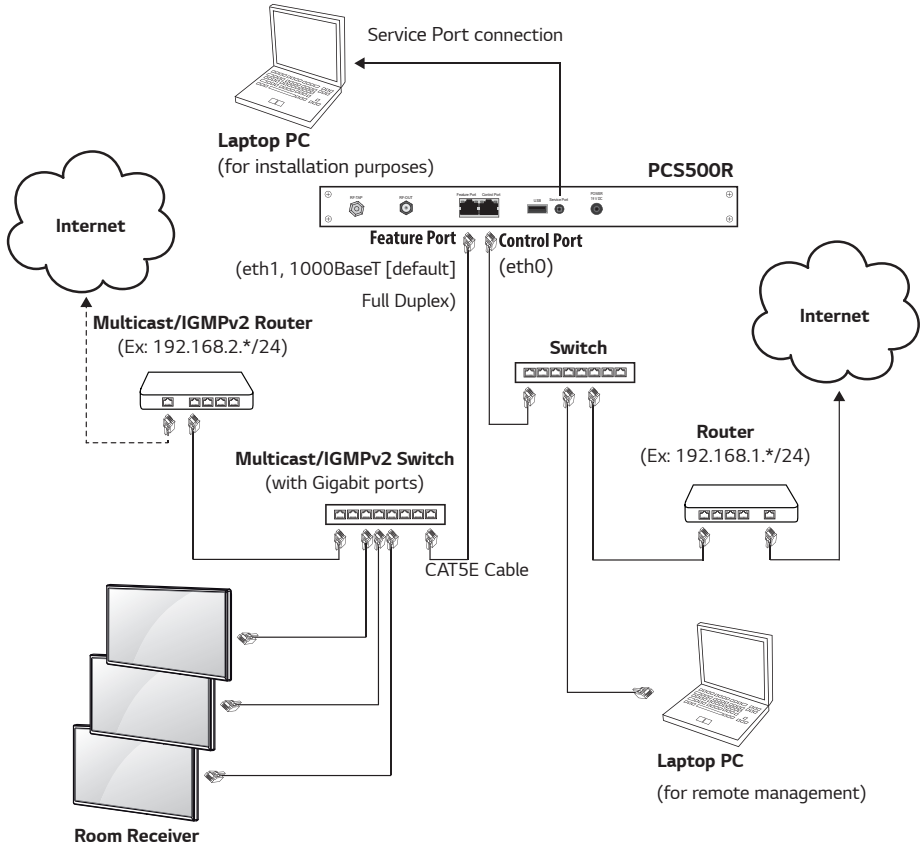

VPN Network Connections Overview

ENGLISH

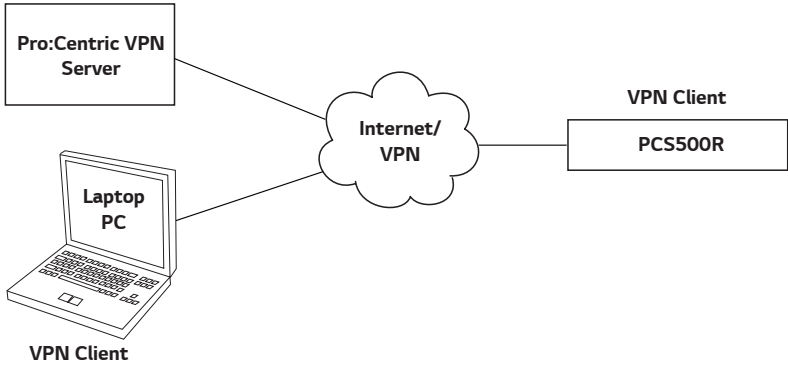

Setting Up the Pro:Centric Network

This section describes how to complete the initial network configuration for the PCS500R. See also typical setup and VPN network connections diagrams above.

- 1 To enable remote management, connect one end of a CAT5 RJ-45 Ethernet cable to the Control Port on the PCS500R rear panel, and connect the other end of the cable to the institution's network.
- 2 Connect the PCS500R power supply to the POWER connector on the PCS500R rear panel. Then, plug the AC power cord into a powered AC line receptacle. When power is applied, the PWR (Power) LED on the PCS500R front panel will initially flash red and then turn green (blinking during boot-up).
The boot-up process for the PCS500R may take several minutes. When boot-up is complete, the PWR LED on the PCS500R front panel will light continuously green.
- 3 Once the PWR LED is lit continuously (no longer blinking), use the FTDI TTL-232R-5V-AJ cable to connect a PC to the Service Port on the PCS500R rear panel.
- 4 Using HyperTerminal or an equivalent terminal emulation program on the PC, configure the serial port as follows: Bits per second/baud = 115200; Data bits = 8; Parity = None; Stop bits = 1; Flow Control = None
Note: To avoid configuration errors, make sure the keyboard settings on the terminal emulator assign the backspace character to Ctrl + H (ASCII 8).
Once the connection is established, you should see a login prompt. (If the login prompt is not automatically displayed, press **Enter** to refresh the screen.)
At the `login as :` prompt, type **admin** and press **Enter**. Then, at the `password :` prompt, type **Password4Partners** (case-sensitive) and press **Enter**.



Note: After the initial system setup is complete, it is highly recommended that you change the admin user password from its default value. See "Change the Login Password" on page 34 for further information.

- 5 The system will display a prompt for you to select the Pro:Centric portal application you will be using:

You must select a portal application to continue.

Available portal applications are:

- ```
1 pca (Java)
2 pcd (HTML)
```

Enter 1 or 2 to select a portal application:

6 Either:

- Type **1** and press **Enter** to select the Java application.
- Type **2** and press **Enter** to select the HTML application.

**Note:** Select the appropriate application based on the purchase order associated with this server. The software license specifies the Java or HTML application, and the application type must be set accordingly in this step.

Once you make your selection, the server will display confirmation before initiating a reboot, for example:

```
You selected the pcd (HTML) application
```

```
System will now reboot to run the selected application
```

7 When the reboot is complete, you should see a new login prompt. Log back in to the server (see step 5).

Once you are logged in, you will see a `Command >` prompt.

The next step describes how to set static IP addresses for the Control Port and/or Feature Port, if desired/applicable. The Control Port is used for remote management/communication purposes, while the Feature Port is designated for PCS500R IP or hybrid RF/IP output. By default, both ports are configured for DHCP.

- **Note:** You can press **Enter** at any PCS500R command prompt to view current menu, if desired.
  - **Note:** To view the server's current configuration settings, type **info** and press **Enter** at the `Command >` prompt. The System Information display will show the IP address that has been assigned to the Control Port (if the network is configured for DHCP) and the output configuration. See "View System Information" on page 25 for further information.
  - **Note:** If the Control Port network is configured for DHCP but the Control Port IP address is not displayed in the System Information display (see note above), refer to "Network Setup" troubleshooting information on page 41. If configured, the DHCP server should assign an IP address to the Control Port once the PCS500R successfully connects to the network.
- 8 (Optional) Set a static IP address for the Control Port and/or Feature Port. It is highly recommended that the Feature Port be configured with a static IP address. See also note below regarding Feature Port.
- **Note:** Static configuration for the Feature Port is recommended, regardless of whether you are configuring the system for Multicast Mode or Unicast Mode, as the Feature Port IP address is embedded in every deployed Pro:Centric application project. After a project has been deployed and any TVs/STBs (to which the project has been deployed) complete a boot cycle, the TVs/STBs automap themselves to the Pro:Centric server using the Feature Port IP address. If the Feature Port IP address is assigned by a DHCP server, and the DHCP server experiences an interruption, the IP address assignment may change, and this will cause a Pro:Centric interruption.
  - **Note:** For detailed information on this step and additional screen samples, see "Modify Network Settings" on pages 26 to 29.

a) At the `Command >` prompt, type **setup** and press **Enter**.

TCP/IP configuration is performed in the CentOS Network Manager TUI (text-based user interface). The system will display the Network Manager menu, for example:

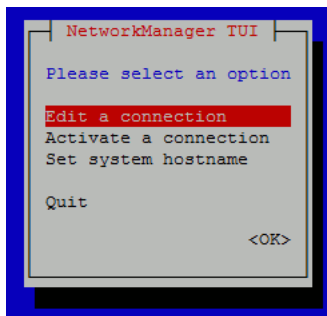

b) Select/highlight **Edit a connection** and press **Enter**.

c) In the next screen, select/highlight the port you wish to configure and press **Enter**.

d) With the Edit Connection screen for the selected port on display:

- \* Add the appropriate IP address in the format `xxx.xxx.xxx.xxx/xx`, where the last two digits (after the forward slash) identify the network mask bits for the IP address.

- \* Add the gateway (if applicable) and DNS IP addresses in the format `xxx.xxx.xxx.xxx`.

See also notes below.



Note: In order to avoid a service interruption, do not modify any of the other fields in the Edit Connection screen. In particular, do NOT modify the data in the Profile Name and Device fields.

Note: The Feature Port IP address MUST be on a different subnet than the Control Port IP address, but should be on the same network as the TVs. Also, while either IPv4 or IPv6 is supported for the Control Port, the Feature Port must be configured on an IPv4 network.

Note: Do not specify a gateway IP address for the Feature Port.

e) When you are finished with network configuration for the selected port, select/highlight **<OK>** at the bottom right of the Edit Connection screen and press **Enter**.

f) Repeat steps (c) to (e), as required, to complete configuration for the second port.

g) When you are finished with port configuration, select/highlight **<Quit>** at the bottom right of the port selection screen and press **Enter** to return to the Network Manager menu. To exit the Network Manager and return to the `Command >` prompt, select **Quit** and press **Enter**.

- **Note:** Review the configuration data for each port carefully before you confirm the settings. Ensure each of the addresses was entered correctly.
- **Note:** You may also edit the host name from the Network Manager menu, if desired. See “Modify the Server Host Name” on pages 30 to 31 for further information. Avoid using spaces or special characters, such as `?`, `-`, etc., in the host name.

9 (Optional) Set the time zone and/or the date and time on the PCS500R.

By default, the PCS500R is synchronized with an NTP server and configured for the US Eastern time zone. If the PCS500R is connected to the Internet, the NTP client will periodically update the time setting on the PCS500R. You can set the time zone as required. If the PCS500R is not connected to the Internet, you also have the option to specify date and time data manually.

Use the PCS500R “tz” and/or “time” commands (available from the `Command >` prompt) and follow the system prompts to set the time zone and/or date and time on the PCS500R, as necessary. See “Set the Time Zone” on pages 32 and/or “Set the Date and Time” on pages 33 for further information.

**Note:** If you changed the time zone, you will be prompted to reset the system. Continue with step 10.

10 If you made any configuration changes in steps 8 or 9, reset the PCS500R: At the `Command >` prompt, type **reset** and press **Enter**.

The reset process may take several minutes, after which the PCS500R resumes normal operation.

11 Make the appropriate connection to the RF distribution system or IP distribution network depending on the PCS500R output option to be used.

- RF output: Connect RF OUT on the PCS500R to the RF distribution center combiner, and balance the RF signal so that the Pro:Centric signal level at the TV(s) is between 0 to +7 dBmV.
- IP output: Connect a CAT5E or better Ethernet cable between the Feature Port on the PCS500R rear panel and the institution’s IP distribution network.



Caution (RF Output only): For proper system performance, the Pro:Centric signal level at the TV input (ANTENNA IN) must be between 0 to +7 dBmV. Note that additional equipment may be required to adjust the signal level.

Caution: When not in use, the RF TAP (0 dBmV) connector must remain terminated with attached terminator accessory.

The remainder of the system setup—configuration of RF or IP output parameters, video playout settings, Pro:Centric Channel Map, etc.—is performed in the Admin Client that is appropriate for your system (based on your selection in step 6 of the procedure above). Refer to either the *Pro:Centric Server Admin Client User Guide* (Java application) or the *Pro:Centric Direct Admin Client User Guide* (HTML application), as applicable, for further information.

**Note:** By default, the server output is enabled for 256-QAM-B modulation (RF output), with the data channel set to 75.

# PCS500R Configuration Options

## Network and Communication Setup

This section describes PCS500R communication options for configuration purposes.



**Note:** Before you proceed with any additional configuration, the PCS500R software should be installed and configured as described in the setup procedure on pages 19 to 22.

Also note that configuration updates periodically require that you reset the PCS500R. Make sure to reset the unit when directed to do so.

There are two typical options for communicating with the PCS500R:

- Use an SSH client to communicate with the PCS500R via a command line interface. If necessary, consult the network administrator to obtain the IP address that has been assigned to/configured for the PCS500R's Control Port.
- To establish a direct connection to the PCS500R, connect a PC to the PCS500R using the FTDI TTL-USB cable (P/N TTL-232R-5V-AJ). Plug the USB end of the cable into an open USB port on your PC. If necessary, install the device driver. Plug the other end of the cable into the Service Port jack on the PCS500R rear panel. Using HyperTerminal or an equivalent terminal emulation program on the PC, configure the serial port as follows:
  - Bits per second/baud = 115,200
  - Data bits = 8
  - Parity = None
  - Stop bits = 1
  - Flow Control = None

**Note:** To avoid configuration errors, make sure the keyboard settings on the terminal emulator assign the backspace character to Ctrl + H (ASCII 8).

You will need to know the "admin" user password in order to log in to the command line interface. The default admin user password is "Password4Partners" (case-sensitive). If necessary, for example, if the password has been changed from its default value, consult the system administrator to obtain the current admin user password.

**Note:** If you want to connect a PC directly to the PCS500R Control Port using an Ethernet CAT5E cable, in order for communication to be established, the PCS500R's IP address must be on the same subnet as the PC's IP address.

## Log In to the PCS500R and Access the Main Menu

**Note:** The PCS500R must be connected to an IP network for SSH client access. For direct access to the PCS500R Service Port, use the FTDI TTL-USB cable (P/N TTL-232R-5V-AJ). See also “Network and Communication Setup” above for further information.

- 1 Establish communication with the PCS500R using an SSH client or via a direct connection to the PCS500R Service Port.  
Once communication is established, you should see a login prompt. (If the login prompt is not automatically displayed, press **Enter** to refresh the screen.)
- 2 At the login as: prompt, type **admin** and press **Enter**.
- 3 At the Password: prompt, type the admin password and press **Enter**.
- 4 At the `Command >` prompt, either:
  - Press **Enter** to display the PCS500R Main Menu (see example below).
  - Type the desired command and press **Enter**.

The following sections describe each of the configuration commands.

**Note:** You can always press **Enter** at the `Command >` prompt to display the PCS500R Main Menu.

### Example: PCS500R Main Menu

#### Main Menu

```

info System information
setip TCP/IP Setup Menu
hostname Set server host name
tz Timezone setup
time Time setup
pwd Change password
portal Select the portal application
monitor System monitor
ping Send ICMP ECHO_REQUEST to network hosts
update Update
vpn VPN setup
shut Shutdown the system
reset System Reset
reinstall Return to factory configuration
exit End the session

```

Command >

## View System Information

1 Log in to the PCS500R as described on the previous page.

2 At the Command prompt, type **info** and press **Enter**.

The System Information display identifies important information about the PCS500R, including the unit serial number, hardware ID (firmware version), software versions, MAC addresses, IP addresses, etc., for example:

```
PCS500R Pro:Centric Server vx.x-xxxx/y.y.y.yyyyy
Copyright (c) 2021 LG Electronics U.S.A., Inc.
```

```
SN: 601-12480013
Hardware ID: 1
FPGA version: 802
BIOS version: 116
BIOS vendor: PCS500v3
CPU SN: 000002703544
OS version: Linux 3.10.0-327.e17.x86_64
OS release:
Ctrl MAC: #1 SMP Mon Jul 29 17:46:05 UTC 2019
Ctrl IP: 00:13:95:21:a2:7d
Ctrl IP V6: 10.1.2.3
Feat MAC: n/a
Feat IP: 00:0C:63:40:47:db
Feat IP V6: 192.168.20.120
VPN IP: n/a
RF config: n/a
RF channel: Mode 3, 256-QAM-B, RF: 6 MHz, 5.36 MSps, ASI: 38.81 Mbps
Channels: 75
Docker vers 1
Portal app: 17.09.0-ce, build afdb6d4
Local time: pcd (HTML)
 Tue Feb 15 17:48:23 CDT 2021
```

Where x.x-xxxx is the version and build number of the HTML application and yyyyyyyy is the version and build number of the Java application.

**Note:** If RF output is configured for DVB-C modulation, the display will identify the RF frequency (in KHz) in place of the RF channel. If IP output is configured, the display will identify the multicast IP address in place of the RF fields.

It is recommended that you record this information for future reference. If you find it necessary to call customer service or engineering support, please have this information available.

## Modify Network Settings

This section describes how to modify the network settings of the PCS500R Ethernet ports. The Control Port is used for remote management/communication purposes, while the Feature Port is designated for PCS500R IP output.

**Note:** It is highly recommended that the Feature Port (if in use) be configured with a static IP address, regardless of whether you are configuring the system for Multicast Mode or Unicast Mode, as the Feature Port IP address is embedded in every deployed Pro:Centric application project. After a project has been deployed and any TVs/STBs (to which the project has been deployed) complete a boot cycle, the TVs/STBs automap themselves to the Pro:Centric server using the Feature Port IP address. If the Feature Port IP address is assigned by a DHCP server, and the DHCP server experiences an interruption, the IP address assignment may change, and this will cause a Pro:Centric interruption.

- 1 Log in to the PCS500R as described on the previous page.
- 2 At the `Command >` prompt, type **setip** and press **Enter**.  
The system will display the Network Manager menu.

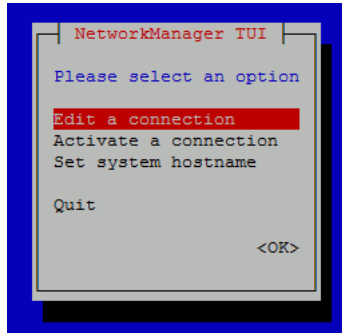

- 3 Select/highlight **Edit a connection** and press **Enter** to modify the IP configuration of either the Control Port or the Feature Port.

**Note:** To exit the Network Manager and return to the Main Menu prompt without modifying any settings, select **Quit**. You may also modify the server's host name from the Network Manager. See "Modify the Server Host Name (via TUI)" on pages 30 for further information.

4 In the next screen, select/highlight the port profile to modify, and then press **Enter**.

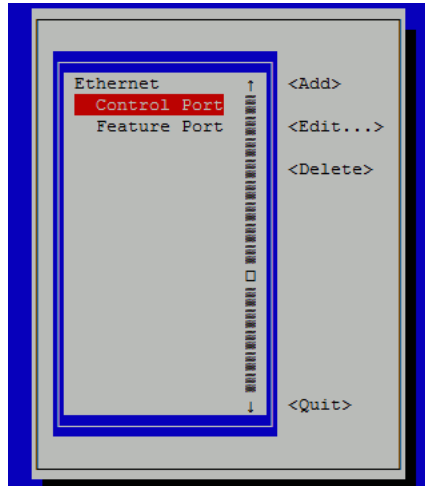

Once you select a port, the Edit Connection screen for that port will be displayed, for example:

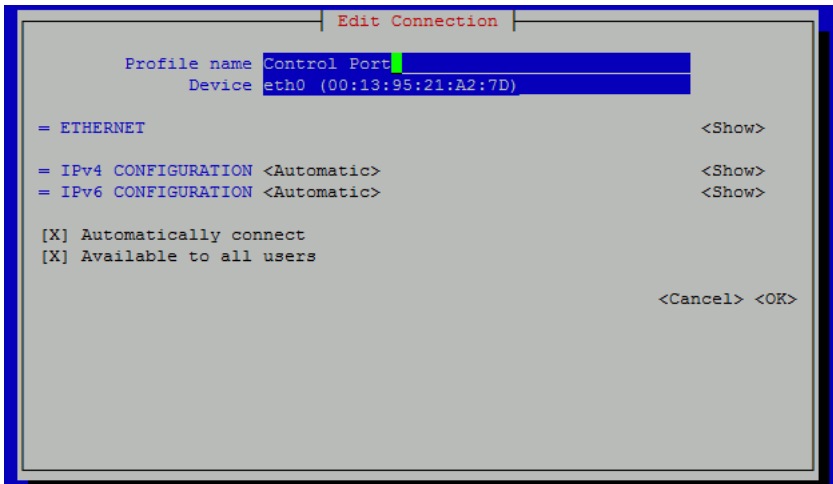



Note: Steps 5 to 9 identify all fields that may require modification for the purposes of the Pro:Centric network. In order to avoid a service interruption, do not modify any of the other fields in the Edit Connection screen. In particular, do NOT modify the data in the Profile Name and Device fields.

Note: The Feature Port IP address MUST be on a different subnet than the Control Port IP address, but should be on the same network as the TVs.

Also, while either IPv4 or IPv6 is supported for the Control Port, the Feature Port must be configured on an IPv4 network.

Note: Do not specify a gateway IP address for the Feature Port.

- 5 To change the port configuration from Automatic to Manual or vice versa, select/highlight the IPv4 Configuration field and press **Enter**. Then, select the appropriate option (**Automatic** or **Manual**) from the drop-down menu.

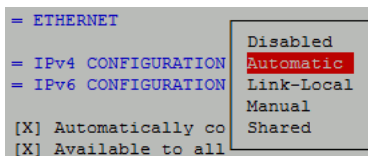

- 6 The next step depends on your selection in the previous step.

- If you selected **Automatic**, go to step 9.
- If you selected **Manual**, continue with step 7.

- 7 If you are configuring static (i.e., manual) settings, select/highlight **<Show>** at the right of the IP Configuration field and press **Enter** to view the expanded configuration fields.

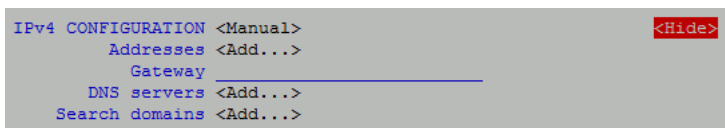

8 Complete the following configuration:

Select/highlight **<Add...>** and press **Enter** in the **Addresses** field. Then, type the appropriate IP address in the format xxx.xxx.xxx.xxx/xx, where the last two digits (after the forward slash) identify the network mask bits for the IP address.

In the Gateway field (Control Port only—see also note above), type the gateway IP address in the format xxx.xxx.xxx.

```
IPv4 CONFIGURATION <Manual> <Hide>
 Addresses <Add...> <Remove>
 Gateway <Add...>
 DNS servers <Add...>
 Search domains <Add...>
```

**Note:** If you do not specify the network mask bits in the port's IP address, as indicated above, the system will not create a local route over the network interface (unless the interface is used as the system's default route).

- Select/highlight **<Add...>** and press **Enter** in the DNS Servers field, and type the primary DNS IP address (in the format xxx.xxx.xxx.xxx). As required, select **<Add...>** again and type the secondary DNS IP address.

```
IPv4 CONFIGURATION <Manual> <Hide>
 Addresses <Add...>
 Gateway <Add...>
 DNS servers <Add...> <Remove>
 Search domains <Add...>
```

9 (Recommended) Change the unused port configuration from **Automatic** to **Ignore**. For example, for the Feature Port, select/highlight the IPv6 Configuration field and press **Enter**. Then, select Ignore from the drop-down list of options.

10 When you are finished, select/highlight **<OK>** at the bottom right of the Edit Connection screen and press **Enter**.

11 Repeat steps 4 to 10 for the second port as required. When you are finished with port configuration, select/highlight **<Quit>** at the bottom right of the port selection screen and press **Enter** to return to the Network Manager menu. To exit the Network Manager and return to the Main Menu prompt, select **Quit** and press **Enter**.

12 If you changed the port configuration, you will need to reset the system. If you are ready to reset the system immediately, at the `Command >` prompt, type **reset** and press **Enter** (see "Reset the System" on page 39 for further information).

**Note:** If you intend to modify additional configuration settings during the current session, you may wait until all changes are complete before you reset the system.

## Modify the Server Host Name (via TUI)

This option enables you modify the PCS500R host name via the Network Manager TUI Menu.

**Note:** You may also use the “hostname” option in the Pro:Centric Direct Main Menu to modify the server’s host name. See “Modify the Server Host Name (via CLI)” on page 31 for further information. The most recent update determines the server’s host name, regardless of which command you choose to use.

- 1 Log in to the server as described on page 24.
- 2 At the `Command >` prompt, type **setip** and press **Enter**.  
The system will display the Network Manager menu, for example:

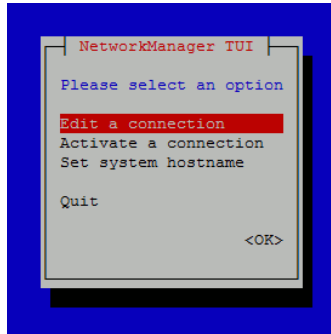

- 3 Select/highlight **Set system hostname** and press **Enter**.

**Note:** To exit the Network Manager and return to the Main Menu prompt without modifying any settings, select **Quit**. You may also modify the Control and/or Feature Port configuration from the Network Manager. See “Modify Network Settings” on pages 26 to 29 for further information.

- 4 The Hostname field in the **Set Hostname** screen shows the current host name. Modify the host name as required (avoid using spaces or special characters, such as ?, -, etc.) and then press **Enter**.

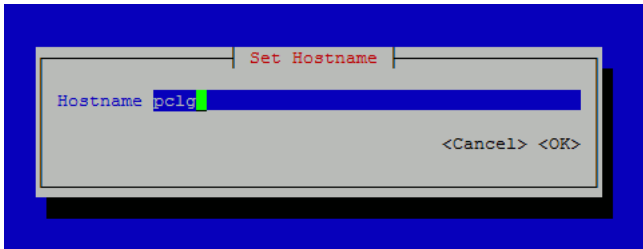

5 At the prompt for confirmation, press **Enter**.

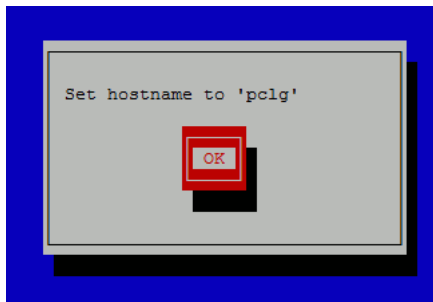

6 If you changed the host name, you will need to reset the system. If you are ready to reset the system immediately, at the `Command >` prompt, type **reset** and press **Enter** (see “Reset the System” on page 39 for further information).

**Note:** If you intend to modify additional configuration settings during the current session, you may wait until all changes are complete before you reset the system.

## Modify the Server Host Name (via CLI)

This option enables you modify the server’s host name via the command line interface.

**Note:** You may also use the “Set system hostname” option in the Network Manager TUI Menu to modify the server’s host name. See “Modify the Server Host Name (via TUI)” on pages 30 for further information. The most recent update determines the server’s host name, regardless of which command you choose to use.

1 Log in to the server as described on page 24.

2 At the `Command >` prompt, type **hostname** and press **Enter**.

The system will prompt you to type the new host name:

```
Enter host name:
```

3 Type the new host name, and then press **Enter**. Avoid using spaces or special characters, such as ?, -, etc.

Once you enter the new host name successfully, the system displays confirmation:

```
Host name has been set. Please reset the system.
```

4 If you are ready to reset the system immediately, at the `Command >` prompt, type **reset** and press **Enter** (see “Reset the System” for further information).

**Note:** If you intend to modify additional configuration settings during the current session, you may wait until all changes are complete before you reset the system.

## Set the Time Zone

- 1 Log in to the PCS500R as described on page 24.
- 2 At the `Command >` prompt, type **tz** and press **Enter**.  
The system displays the current time zone information for the PCS500R and prompts you to specify whether or not you wish to change the time zone.  
Current time zone is: America/New York  
Change the time zone? [y/n]:
- 3 Either:
  - Type **n** and press **Enter** to return to the Main Menu `Command >` prompt without changing the current time zone.
  - Type **y** and press **Enter** to change the time zone. Then, continue with step 4.
- 4 The system will display the following prompt for a location, followed by a list of options:  
Please identify a location so that time zone rules can be set correctly.  
Please select a continent or ocean.  
At the #? prompt, type the number that corresponds to the appropriate option for your location, and then press **Enter**.
- 5 The system will display the following prompt for a country, followed by a list of options:  
Please select a country.  
At the #? prompt, type the number that corresponds to the appropriate option for your country, and then press **Enter**.
- 6 The system will display the following prompt for a region, followed by a list of options:  
Please select one of the following time zone regions.  
At the #? prompt, type the number that corresponds to the appropriate option for your region, and then press **Enter**.  
After you specify the time zone region, the system displays an overview of your location selections and prompts for confirmation, for example:  
  
The following information has been given:  
United States  
Central Time  
Therefore TZ='America/Chicago' will be used.  
Local time is now: Tue Feb 15 11:58:48 CDT 2021.  
Universal Time is now: Tue Feb 15 16:58:48 CDT 2021.  
Is the above information OK? [y/n]:
- 7 Either:
  - Type **y** and press **Enter** if the information in the display is correct. The system will confirm the setting and then prompt you to reset the PCS500R:  
Timezone has been changed.  
Please restart the server.
  - Continue with step 8.
 Type **n** and press **Enter** to return to the initial location prompt and reset the time zone (repeat this procedure from step 4).
- 8 If you are ready to reset the system immediately, at the `Command >` prompt, type `reset` and press **Enter** (see “Reset the System” on page 39 for further information).  
**Note:** If you intend to modify additional configuration settings during the current session, you may wait until all changes are complete before you reset the system.

## Set the Date and Time

By default, the PCS500R is synchronized with an NTP server and configured for the US Eastern time zone. If the PCS500R is connected to the Internet, the NTP client will periodically update the time setting on the PCS500R. If the PCS500R is not connected to the Internet, you also have the option to specify date and time data manually. Refer to "Set the Time Zone" above for information on setting the time zone.

1 Log in to the PCS500R as described on page 24.

2 At the `Command >` prompt, type **time** and press **Enter**.

The system will display the current time (for example: Current time: 2021-02-15 15:45:44) and then initiate a series of prompts to enable you to set the time.

3 At each of the following prompts, type the year, month, day, hour, and minute, respectively. Note that each of these fields requires numerical values, and the hour should be entered in 24-hour format. Press **Enter** after each entry.

If applicable, you can also press **Enter** at each prompt to accept the default value in square brackets.

```
Enter new year [2021]>
```

```
Enter new month [02]>
```

```
Enter new day [15]>
```

```
Enter new hour (0-23) [15]>
```

```
Enter new minute [45]>
```

Once you enter the minute value, the system will display the new time and then prompt for confirmation, for example:

```
New time: 2021-02-15 15:46:00
```

```
Apply? [y/n]:
```

4 Either:

- Type **y** and press **Enter** to apply the new time configuration. The system will confirm the setting and then prompt you to reset the PCS500R:

```
Time is set. Please reset the system.
```

Continue with step 5.

Type **n** and press **Enter** to return to the `Command >` prompt without changing the time configuration.

5 If you are ready to reset the system immediately, at the `Command >` prompt, type **reset** and press **Enter** (see "Reset the System" on page 39 for further information).

**Note:** If you intend to modify additional configuration settings during the current session, you may wait until all changes are complete before you reset the system.

## Change the Login Password

For security purposes, it is recommended that the admin user login password be unique to the system. Note that the login password is case-sensitive.

- 1 Log in to the PCS500R as described on page 24.
- 2 At the `Command >` prompt, type **pwd** and press **Enter**.  
The system prompts for the current admin user password:  
Changing password for admin  
Old password:
- 3 Type the current password and press **Enter**. The system will then prompt you to type and retype the new password:  
New password:  
Retype password:
- 4 Type and then retype the new password at the prompts. Press **Enter** after each entry.  
Once you complete the Password fields successfully, the system displays confirmation:  
Password for admin changed by admin.

## Change the Portal Application

This option enables you to change the portal application (Java or HTML), if necessary.



**Caution: This option will create a temporary system interruption and should be used only when necessary. After you complete the procedure below, you must perform a number of additional steps in the appropriate Admin Client (i.e., the Admin Client for the new application) in order for portal functionality to be initiated. Software feature licensing, output configuration, and portal configuration are not ported from one application to the other.**

- 1 Log in to the PCS500R as described on page 24.
- 2 At the `Command >` prompt, type **portal** and press **Enter**.  
The system prompts for confirmation that you wish to make a change, for example:  
The system is configured to use the pcd (HTML) portal application.  
Do you wish to change the portal application? [y/n]:

## 3 Either:

- Type **y** and press **Enter** to continue. The system will display the available applications, followed by a prompt for a selection:

```
Available portal applications are:
 1) pca (Java)
 2) pcd (HTML)
Select a new portal application [2]:
```

Continue with step 4.

- Type **n** and press **Enter** to return to the Main Menu without changing the portal application.

## 4 At the prompt to select a new portal application, either:

- Type **1** and press **Enter** to select the Java application.
- Type **2** and press **Enter** to select the HTML application.

**Note:** Select the appropriate application based on the purchase order associated with this server. The software license specifies the Java or HTML application, and the application type must be set accordingly.

Once you make your selection, the server will display confirmation and prompt you to reboot the system, for example:

```
Successfully set to pca (Java) portal application
You must reset the system now.
Are you sure you want to reset the system? [y/n]:
```

## 5 Either:

- Type **y** and press **Enter** to initiate an immediate reset of the PCS500R. The reset process may take several minutes, after which the system resumes normal operation.
- Type **n** and press **Enter** to return to the Main Menu without resetting the system at the current time; however, note that you must eventually reset the system in order to apply the new portal application configuration.
- See “Reset the System” on page 39 when you are ready to reset the system.

**Note:** If you intend to modify additional configuration settings during the current session, you may wait until all changes are complete before you reset the system.

The remainder of the new portal application setup—configuration of feature set, output parameters, video playout settings, Pro:Centric Channel Map, customized portal interactive menus, etc.—is performed in the appropriate Admin Client, as indicated at the beginning of this section. Refer to either the *Pro:Centric Server Admin Client User Guide* (Java application) or the *Pro:Centric Direct Admin Client User Guide* (HTML application), as applicable, for further information.



**Caution:** When your Admin Client portal configuration activities are complete, you must reset the server to activate the new application configuration.

## Monitor the System

This option enables you to view dynamic system streaming data.

- 1 Log in to the PCS500R as described on page 24.
- 2 At the `Command >` prompt, type **monitor** and press **Enter** to display the current system data. See example on following page.
- 3 The system data will refresh every second. When you are finished monitoring streaming data, press **Enter** to stop the system monitor and return to the `Command >` prompt.

### **Example: System Monitor Display (QAM-B RF Output, HTML Application)**

SYSTEM MONITOR

```
Date: 2021-02-15 16:44:27
SN: 601-12480013
Version: 1.2
Output: RF_QAM256_6M
Pg/RF: 2
```

Bitrates (Mbps):

| Slot | Content    | Secs | Mbit | Pct | RF Out  |
|------|------------|------|------|-----|---------|
| 1    | GEM Data   | 685  | 8.9  | -   | 75-1    |
| 4    | Video1.ts  | 6    | 5.1  | 1   | 76-1 :) |
| 5    | Video2.trp | 205  | 4.6  | 78  | 76-2 :) |
| 7    | Video3.ts  | 40   | 4.2  | 12  | 77-1 :) |
| 8    | Video4.trp | 172  | 2.7  | 66  | 77-2 :) |
| 10   | Video5.ts  | 12   | 3.5  | 3   | 78-1 :) |
| 11   |            | -    | 0.0  | -   | 78-2    |
| 13   | Video6.ts  | 171  | 4.7  | 94  | 79-1 :) |
| 14   |            | -    | 0.0  | -   | 79-2    |
| 16   |            | -    | 0.0  | -   | 80-1    |
| 17   |            | -    | 0.0  | -   | 80-2    |
| 19   |            | -    | 0.0  | -   | 81-1    |
| 20   |            | -    | 0.0  | -   | 81-2    |
| 22   |            | -    | 0.0  | -   | 82-1    |
| 23   |            | -    | 0.0  | -   | 82-2    |

Press <Enter> key to exit the monitor

The system monitor display shows streaming data for each of the active video programs. The first column in the display shows the channel slot numbers for which video playlists can be defined. Slots 1 and 2 are reserved for GEM/site data and Slot 3 is unused (and is not shown in the display). On servers configured with the Pro:Centric Java application, it is possible to add a site video to Slot 2, and so for these systems, Slot 2 will appear in the system monitor display. On the other hand, it is not possible to add a site video to Slot 2 on servers that are configured with the Pro:Centric Direct HTML application, and so for these systems, Slot 2 will not appear in the system monitor display. The system monitor example below shows data for a system that is configured for QAM-B RF output with the Pro:Centric Direct HTML application.

**Note:** Output parameters are configured in the Admin Client. Refer to either the Pro:Centric Server Admin Client User Guide (Java application) or the Pro:Centric Direct Admin Client User Guide (HTML application), as applicable, for further information.

## Send Ping Commands to Network Hosts

This option enables you to ping network hosts for troubleshooting purposes. Multiple data variables (flags) are available, as described below.

- 1 Log in to the server as described on page 24.
- 2 At the `Command >` prompt, you can either:
  - Type **ping destination**, where destination is the IP address or domain name of the network host, and then press **Enter** to ping the desired network host without any ping option flags. The system will continue to send ping messages and display data until you press **Enter**.
  - Type a ping command with flags (see examples below) and press **Enter** to collect specific data. Each flag name and input should be preceded and followed by a space, as shown in the Ping Commands With Flags example below.
    - If you did not specify the number of messages to send, the system will continue to send ping messages and display data until you press **Enter**.
  - Type **ping** and press **Enter** to display information on ping command options. See Ping Command Usage Information example below.
- 3 (Unlimited messages only) When you are finished monitoring ping data, press **Enter** to stop the ping messages and return to the `Command >` prompt.

Once the ping messages are stopped (either manually via **Enter** press or via a Count flag), the system will display a summary of the ping statistics.

*Example: Ping Commands With Flags*

**Note:** Ping commands are not case-sensitive; however inputs are limited to letters and/or numbers (Aa, Bb, Cc, 1, 2, 3, etc.) and dot, hyphen, and underscore (., -, and \_) characters.

```
ping 1.2.3.4 c 2
ping 1.2.3.4 c 4 i eth0
ping 1.2.3.4 c 2 s 20 t 3
```

### **Example: Ping Command Usage Information**

```
Usage: ping <destination> [count c] [SIZE s] [TTL t] [INTERAFCE i]
Send ICMP ECHO_REQUEST messages to the specified address.
```

Optional flags:

```
COUNT c is the number of messages to send, default is unlimited
SIZE s is the number of data bytes, default is 50
TTL t is the IP packet's TTL value
INTERFACE i is the interface to send from, such as eth0 or eth1
```

Flag names may be shortened, e.g. you may type `t` instead of `TTL`.

All options are limited to the set of alphanumeric characters and dot, hyphen, and underscore: `a-z A-Z 0-9 . - _`

Command `>`

## Update the Pro:Centric Application

This option is only applicable for the Java portal application. It enables you to update the Java Pro:Centric application via the Ethernet. Note that the update replaces the application and clears all user settings, but preserves the application license.



**Caution: Do NOT initiate simultaneous menu sessions while a software update is in progress. Doing so may interfere with the active process and may corrupt the system configuration and/or cause the PCS500R to cease normal operation.**

The appropriate update file must be provided by LG; the system will not download an improper file.

- 1 Log in to the PCS500R as described on page 24.
- 2 At the `Command >` prompt, type `update` and press **Enter**.
- 3 At the **Enter** `update filename:` prompt, type in the software update filename and press **Enter**.  
The system will initiate the download and confirm progress, for example:  
`Downloading file: pcs400r_app_xxxx.upd`
- 4 When the update is successfully completed, reset the system (see “Reset the System” on page 39 for further information).

## Update the VPN Setup

This option is only applicable for the Java portal application. It enables you to update the VPN client via a serial link to the PCS500R.

The appropriate update file must be provided by LG; the system will not transfer an improper file.

- 1 Log in to the PCS500R as described on page 24.
- 2 At the `Command >` prompt, type `vpn` and press **Enter**.
- 3 At the `Send VPN client file using Xmodem...` prompt, transfer the new VPN client file using Xmodem protocol. For example, in HyperTerminal, select **Transfer** and then **Send File...** In the Send File window, enter or select the appropriate filename in the Filename field, and select **Xmodem** in the Protocol field.  
The update process may take several minutes. The system will display progress messages as well as the result of the update process.
- 4 When the update is successfully completed, reset the system (see “Reset the System” on page 39 for further information).

## Shut Down the System

This command allows you to shut down the system in an orderly manner. Use this command to shut down the PCS500R, for example, if you intend to physically move the unit from one location to another. It is also recommended that you run this command from the PCS500R Service Port in order to track detailed shutdown log messages.

**Note:** Once you use this command, you must remove power from (i.e., unplug) the unit and then plug the AC power cord back into a powered AC line receptacle when you are ready to restart the server. It is not possible to restart the server remotely.

- 1 Log in to the PCS500R as described on page 24.
- 2 At the `Command >` prompt, type `shut` and press **Enter**.  
The system will prompt for confirmation:  
`Are you sure you want to shut down the system? [y/n]:`
- 3 Either:
  - Type **y** and press **Enter** to shut down the system immediately. The shutdown typically takes about a minute. When the PCS500R is in its shutdown state, the front panel LED will blink steadily green.
  - Type **n** and press **Enter** to return to the Main Menu without shutting down the system.

## Reset the System

- 1 If not already logged in, log in to the PCS500R as described on page 24.
- 2 At the `Command >` prompt, type `reset` and press **Enter**.  
The system will prompt for confirmation:  
`Are you sure you want to reset the system? [y/n]:`
- 3 Either:
  - Type **y** and press **Enter** to initiate an immediate reset of the PCS500R. The reset process may take several minutes, after which the system resumes normal operation.
  - Type **n** and press **Enter** to return to the Main Menu without resetting the system.

## Reinstall the Factory Configuration

This option reinstalls the Pro:Centric carousels to their factory default configuration, which may be useful for recovering from a system interruption.



**Caution:** This command removes portal content, media files, etc. After you run the command, TVs/STBs will no longer receive application downloads until you rebuild the application/re-add media files.

**Note:** This command will not affect the server's network configuration and also preserves the feature set, if installed.

1 Log in to the PCS500R as described on page 24.

2 At the Command > prompt, type **reinstall** and press **Enter**.

The system will display a warning and then prompt for confirmation:

```
WARNING!
```

```
You are about to reinstall the application carousels.
```

```
This will reset the Pro:Centric carousels to the
factory default configuration and will delete any
installed software updates or media files.
```

```
It will not change configured network settings.
```

```
Are you sure you want to reinstall the carousels? [y/n]:
```

3 Either:

- Type **y** and press **Enter** to continue.

- Type **n** and press **Enter** to return to the Main Menu without reinstalling the Pro:Centric carousels.

If you opt to continue, progress messages will be displayed as the carousels are restored to the factory default configuration. When the installation is successfully completed, you will be prompted to reset the system:

```
Successfully reinstalled factory carousel applications
```

```
Done
```

```
Please reset the system.
```

4 Reset the system (see "Reset the System" on page 39 for further information).

## Exit the Current Session

At the Command > prompt, type **exit** and press **Enter** to end the current session.

# Troubleshooting

## PCS500R Setup

The following sections provide basic troubleshooting information for the PCS500R.

### Equipment Setup Review

- Make sure all connectors and connections are tight and secure on all entertainment system components.
- Check the PCS500R LED. Under standard operating conditions, i.e., when the PCS500R is booted and operating normally, the PWR (Power) LED on the PCS500R front panel is continuously lit green. If there is a hardware fault, the PWR LED will turn and stay red.

**Note:** When power is first applied to the PCS500R, the PWR LED initially flashes red and then turns green (blinking during boot-up).

### Network Setup

If the network is configured for DHCP but the PCS500R has not been assigned an IP address, i.e., the Ctrl IP field in the PCS500R System Information display is blank:

- 1 Check the Control Port connector on the rear panel of the PCS500R. Make sure the cable connection is tight and secure.
- 2 Observe the green LED on the Control Port. Once the PCS500R is connected to the network, the LED will be lit continuously.
- 3 Contact the network administrator to verify the network status and check that the DHCP server is working properly.

# PCS500R Communication

If you are unable to establish remote communication with the PCS500R, refer to the following flow chart.

ENGLISH

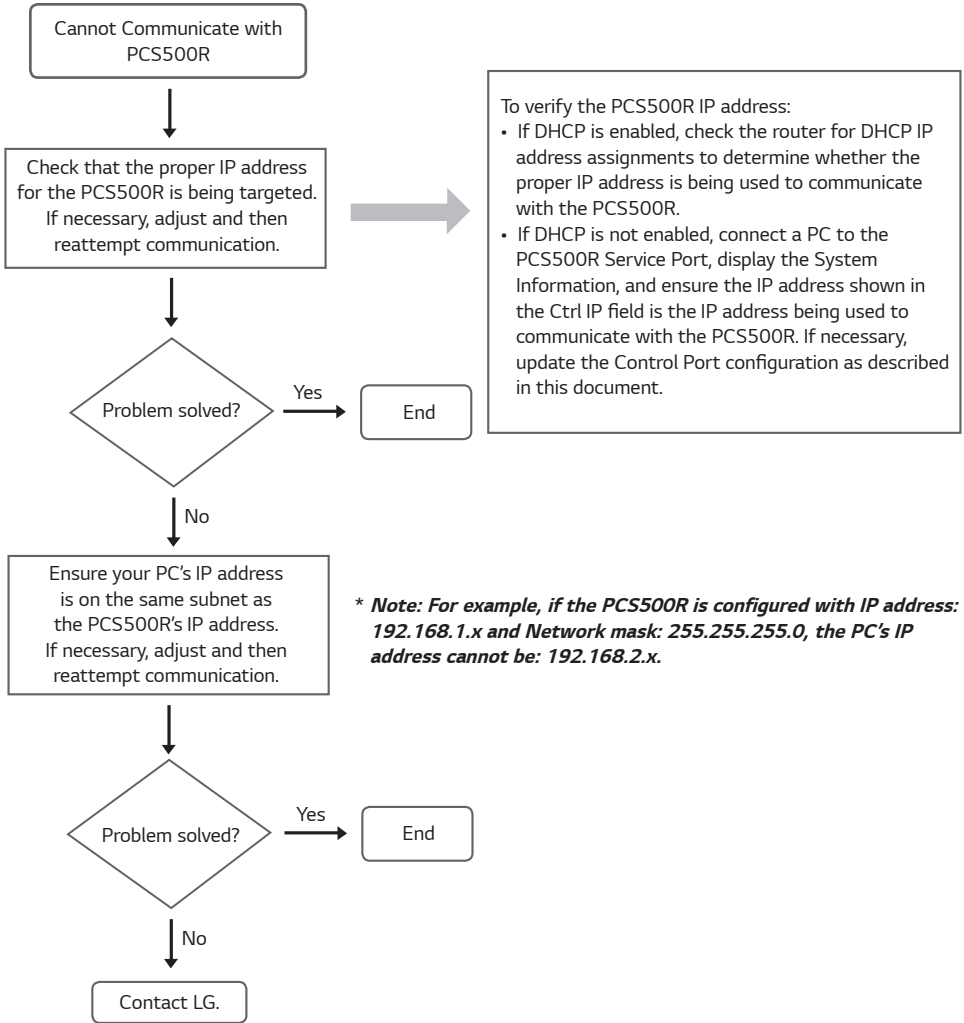

# Specifications

**Note:** Design and specifications subject to change without prior notice.

| Dimensions |                                                            |
|------------|------------------------------------------------------------|
| Height     | 42.977 mm (1.6 inches)                                     |
| Width      | 482.6 mm (19 inches) (for EIA standard 19-inch rack mount) |
| Depth      | 215.9 mm (8.5 inches)                                      |
| Weight     | 2.63 kg (5.7 lbs) (rack-only weight)                       |

| Environmental Operating Conditions |                                            | Environmental Storage Conditions |                                               |
|------------------------------------|--------------------------------------------|----------------------------------|-----------------------------------------------|
| Temperature (Tma)                  | 0° to 35° Celsius<br>32° to 95° Fahrenheit | Temperature (Tma)                | -20° to 70° Celsius<br>-4° to 158° Fahrenheit |
| Humidity                           | 95 % non-condensing                        | Humidity                         | 95 % non-condensing                           |

| Electrical                          |                                                                                                                           |
|-------------------------------------|---------------------------------------------------------------------------------------------------------------------------|
| RF Out Connectors (2)*              | 75 Ohm, Type 'F'                                                                                                          |
| Frequency                           | VHF/UHF 54 - 865 MHz                                                                                                      |
| RF Output Span                      | Up to 8 Contiguous Channels<br>(within 120 MHz span)                                                                      |
| RF Output Frequency Range           | 54 MHz to 865 MHz                                                                                                         |
| Active Output Level at RF Out jacks | -1 dBm (+47.75 dBmV) Typical                                                                                              |
| Test Output Level                   | -47.75 dBm (+1 dBmV) Typical                                                                                              |
| Frequency Accuracy                  | ±5ppm                                                                                                                     |
| DC Input                            | +19 V DC @ 2.2 Amps                                                                                                       |
| Ethernet Connector (Control Port)   | 10/100/1000BaseT, RJ-45                                                                                                   |
| Ethernet Connector (Feature Port)   | 1000BaseT Full Duplex, RJ-45                                                                                              |
| USB Port                            | USB 3.0                                                                                                                   |
| Solid State Drive                   | UL Listed, FCC compliant, and/or other applicable agency-recognized/<br>listed (Maximum current draw = +5V DC @ 2.0 Amps) |

\* RF TAP connector reserved for service technician use only.

| Modulation Specifications |                                                 |
|---------------------------|-------------------------------------------------|
| Standard                  | ITU-T J.83 Annex B (QAM-B)                      |
| Constellations            | 64-QAM, 256-QAM                                 |
| Symbol Rate               | 64-QAM 5.056941 MBaud<br>256-QAM 5.360537 MBaud |
| Interleaving              | Fixed I = 128, J = 1                            |

|                |                                                                                            |
|----------------|--------------------------------------------------------------------------------------------|
| Standard       | EN 300 429 V1.2.1 (DVB-C)                                                                  |
| Constellations | 64-QAM, 256-QAM                                                                            |
| Symbol Rate    | 64-QAM / 256-QAM 5.056 MBaud<br>64-QAM / 256-QAM 6.111 MBaud<br>64-QAM / 256-QAM 6.9 MBaud |

|             |                                                                                |
|-------------|--------------------------------------------------------------------------------|
| Standard    | ABNT NBR 15601:2007 (ISDB-T)                                                   |
| Parameters  | 64-QAM, 7/8 Convolutional Code, 1/32 Guard Interval Ratio, 2K FFT, 13 Segments |
| Sample Rate | 8.126984Ms/s                                                                   |

## Reference: Network Communication Port Protocols

This section lists the ports that should be enabled on the Pro:Centric network in order to support communication protocols between the Pro:Centric server and TVs/STBs. Make sure not to assign any ports that will conflict with other protocols in use.

### On the Control Network:

| Port Number      | Protocol                                                                                                                                           |
|------------------|----------------------------------------------------------------------------------------------------------------------------------------------------|
| Ports 443 & 1194 | VPN for remote access                                                                                                                              |
| Port 9934        | Admin Client for Pro:Centric GUI                                                                                                                   |
| Port 21          | <ul style="list-style-type: none"> <li>• FTP for:</li> <li>• EPG data updates</li> <li>• Video files upload for multiple video channels</li> </ul> |
| Port 80          | HTTP for weather updates                                                                                                                           |
| Port 123         | NTP time/date fetch                                                                                                                                |

### On the Feature Network:

| Port Number | Protocol                                    |
|-------------|---------------------------------------------|
| Port 9443   | Automapping                                 |
| Port 9555   | Events                                      |
| Port 8070   | (Default) Application delivery over Unicast |
| Port 8080   | VOD                                         |
| Port 80     | HTTP                                        |

# Document Revision History / Notes

| Date                                                                                                               | Description              |
|--------------------------------------------------------------------------------------------------------------------|--------------------------|
| March 2021                                                                                                         | Revision A: New document |
| Product documentation is available online at: <a href="http://www.lg.com/us/business">www.lg.com/us/business</a> . |                          |

## Open Source Software Notice

|                    |                    |
|--------------------|--------------------|
| Product Type       | Pro:Centric Server |
| Model Number/Range | PCS500R            |

Those products identified by the Product Type and Model Range above from LG Electronics, Inc. ("LGE") contain the open source software detailed below. Please refer to the indicated open source licences for the terms and conditions of their use.



**Warning: The PCS500R is intended for Commercial use only. It is not a Consumer product and should not be installed in residential dwellings.**

To obtain the source code under GPL, LGPL, MPL, and other open source licenses, that is contained in this product, please visit <https://opensource.lge.com>. In addition to the source code, all referred license terms, warranty disclaimers and copyright notices are available for download.

LG Electronics will also provide open source code to you on CD-ROM for a charge covering the cost of performing such distribution (such as the cost of media, shipping, and handling) upon email request to [opensource@lge.com](mailto:opensource@lge.com). This offer is valid for a period of three years after our last shipment of this product. This offer is valid to anyone in receipt of this information.

# Regulatory

## FCC Notice

(For USA)

This equipment has been tested and found to comply with the limits for a Class B digital device, pursuant to Part 15 of the FCC Rules. These limits are designed to provide reasonable protection against harmful interference in a residential installation. This equipment generates, uses, and can radiate radio frequency energy and, if not installed and used in accordance with the instructions, may cause harmful interference to radio communications. However, there is no guarantee that interference will not occur in a particular installation. If this equipment does cause harmful interference to radio or television reception, which can be determined by turning the equipment off and on, the user is encouraged to try to correct the interference by one or more of the following measures:

- Reorient or relocate the receiving antenna.
- Increase the separation between the equipment and the receiver.
- Connect the equipment to an outlet on a circuit different from that to which the receiver is connected.
- Consult the dealer or an experienced radio/TV technician for help.

This device complies with part 15 of the FCC Rules. Operation is subject to the following two conditions:

(1) this device may not cause harmful interference and (2) this device must accept any interference received, including interference that may cause undesired operation. Any changes or modifications in construction of this device which are not expressly approved by the party responsible for compliance could void the user's authority to operate the equipment.

## FCC Radio Frequency Interference Requirements (for UNII devices)

(For USA)

High power radars are allocated as primary users of the 5.25 to 5.35 GHz and 5.65 to 5.85 GHz bands. These radar stations can cause interference with and/or damage this device. This device cannot be co-located with any other transmitter.

## FCC RF Radiation Exposure Statement

(For USA)

[For having wireless function (WLAN, Bluetooth,...)]

This equipment complies with FCC radiation exposure limits set forth for an uncontrolled environment. This transmitter must not be co-located or operating in conjunction with any other antenna or transmitter.

This equipment should be installed and operated with minimum distance 20 cm (7.8 inches) between the antenna and your body. Users must follow the specific operating instructions for satisfying RF exposure compliance.

## Industry Canada Statement

(For Canada)

[For having wireless function (WLAN, Bluetooth,...)]

This device contains licence-exempt transmitter(s)/receiver(s) that comply with Innovation, Science and Economic Development Canada's licence-exempt RSS(s). Operation is subject to the following two conditions:

(1) This device may not cause interference.

(2) This device must accept any interference, including interference that may cause undesired operation of the device.

## IC Radiation Exposure Statement

(For Canada)

[For having wireless function (WLAN, Bluetooth,...)]

This equipment complies with IC radiation exposure limits set forth for an uncontrolled environment. This equipment should be installed and operated with minimum distance 20 cm (7.8 inches) between the antenna & your body.

**NOTE:** THE MANUFACTURER IS NOT RESPONSIBLE FOR ANY RADIO OR TV INTERFERENCE CAUSED BY UNAUTHORIZED MODIFICATIONS TO THIS EQUIPMENT. SUCH MODIFICATIONS COULD VOID THE USER'S AUTHORITY TO OPERATE THE EQUIPMENT.

## RSS-247 Requirement

(For Canada)

[For product having the wireless function using 5 GHz frequency bands]

(1) The device for operation in the band 5150–5250 MHz is only for indoor use to reduce the potential for harmful interference to co-channel mobile satellite systems;

(2) For devices with detachable antenna(s), the maximum antenna gain permitted for devices in the bands 5250-5350 MHz and 5470-5725 MHz shall be such that the equipment still complies with the e.i.r.p. limit;

(3) For devices with detachable antenna(s), the maximum antenna gain permitted for devices in the band 5725-5850 MHz shall be such that the equipment still complies with the e.i.r.p. limits as appropriate; and

(4) [For devices operating in the band 5250-5350 MHz having an e.i.r.p. greater than 200 mW] Antenna type(s), antenna models(s), and worst-case tilt angle(s) necessary to remain compliant with the e.i.r.p. elevation mask requirement set forth in section 6.2.2.3 of RSS-247 shall be clearly indicated.

Users should also be advised that high-power radars are allocated as primary users (i.e. priority users) of the bands 5250-5350 MHz and 5650-5850 MHz and that these radars could cause interference and/or damage to LE-LAN devices.







## WARNING!

Never place a television set in an unstable location. A television set may fall, causing serious personal injury or death. Many injuries, particularly to children, can be avoided by taking simple precautions such as:

- Using cabinets or stands recommended by the manufacturer of the television set.
- Only using furniture that can safely support the television set.
- Ensuring the television set is not overhanging the edge of the supporting furniture.
- Not placing the television set on tall furniture (for example, cupboards or bookcases) without anchoring both the furniture and the television set to a suitable support.
- Not placing the television set on cloth or other materials that may be located between the television set and supporting furniture.
- Educating children about the dangers of climbing on furniture to reach the television set or its controls.

If your existing television set is being retained and relocated, the same considerations as above should be applied.

## Symbols

|                                                                                  |                                     |
|----------------------------------------------------------------------------------|-------------------------------------|
|  | Refers to alternating current (AC). |
|  | Refers to direct current (DC).      |
|  | Refers to class II equipment.       |
|  | Refers to stand-by.                 |
|  | Refers to "ON" (power).             |
|  | Refers to dangerous voltage.        |

# LG PCS500R Pro:Centric Server Warranty

|                           |                                                                                                                                                                                                                                                                                                                                         |
|---------------------------|-----------------------------------------------------------------------------------------------------------------------------------------------------------------------------------------------------------------------------------------------------------------------------------------------------------------------------------------|
| <b>Broadcast Products</b> | Welcome to the LG family! We believe that you will be pleased with your new PCS500R Pro:Centric Server. Please read this warranty carefully, it is a "LIMITED WARRANTY" as defined under Federal Law. This warranty gives you specific legal rights, and you may also have other rights that vary from state-to-state within the U.S.A. |
|---------------------------|-----------------------------------------------------------------------------------------------------------------------------------------------------------------------------------------------------------------------------------------------------------------------------------------------------------------------------------------|

## LG's RESPONSIBILITY

|                         |                                                                                                                                                                                                                                                                                                                                                                                                                          |
|-------------------------|--------------------------------------------------------------------------------------------------------------------------------------------------------------------------------------------------------------------------------------------------------------------------------------------------------------------------------------------------------------------------------------------------------------------------|
| <b>Warranty Term</b>    | One year parts and labor from date of purchase or delivery date.                                                                                                                                                                                                                                                                                                                                                         |
| <b>Parts</b>            | New or remanufactured replacements for factory-defective parts may be used. Such replacement parts are warranted for the remaining portion of the original warranty period.                                                                                                                                                                                                                                              |
| <b>Warranty Service</b> | Warranty service is provided at LG. Customer pays for shipping charges to LG; LG pays for return shipping charges to return PCS500R Pro:Centric Server to customer. Call 1-888-865-3026 for further information.                                                                                                                                                                                                         |
| <b>Not Covered</b>      | This warranty covers manufacturing defects and does not cover installation, adjustment of customer controls, installation or repair of antenna systems, cable converters or cable company-supplied equipment; it also does not cover damage due to misuse, abuse, negligence, acts of God or other causes beyond the control of LG. Any alteration of the product after manufacture voids this warranty in its entirety. |

**THIS WARRANTY IS IN LIEU OF ANY OTHER WARRANTY, EXPRESS OR IMPLIED, INCLUDING WITHOUT LIMITATION, ANY WARRANTY OF MERCHANTABILITY OR FITNESS FOR A PARTICULAR PURPOSE, AND LG SHALL NOT BE LIABLE FOR ANY CONSEQUENTIAL, INDIRECT, OR INCIDENTAL DAMAGES OF ANY KIND, INCLUDING LOST REVENUES OR PROFITS IN CONNECTION WITH THIS PRODUCT. SOME STATES DO NOT ALLOW LIMITATIONS ON HOW LONG AN IMPLIED WARRANTY LASTS OR THE EXCLUSION OR LIMITATION OF INCIDENTAL OR CONSEQUENTIAL DAMAGES, SO THE ABOVE LIMITATIONS OR EXCLUSIONS MAY NOT APPLY TO YOU.**

(Not supported for Mexico)

### OWNER'S RESPONSIBILITY

|                                |                                                                                                                                                                                                                                                                                                                                                                                                                      |
|--------------------------------|----------------------------------------------------------------------------------------------------------------------------------------------------------------------------------------------------------------------------------------------------------------------------------------------------------------------------------------------------------------------------------------------------------------------|
| <b>Effective Warranty Date</b> | Warranty begins on the date of delivery of the PCS500R Pro:Centric Server.<br><b>For your convenience, keep the dealer's dated bill of sale or delivery ticket as evidence of the purchase date.</b>                                                                                                                                                                                                                 |
| <b>Installation Guide</b>      | Read the Installation & Setup Guide carefully so that you will understand the operation of the PCS500R Pro:Centric Server and how to adjust the settings.                                                                                                                                                                                                                                                            |
| <b>Warranty Service</b>        | <b>For warranty service information, call 1-888-865-3026.</b> Parts and service labor that are LG's responsibility (see above) will be provided without charge. Other service is at the owner's expense. If you have any problem in obtaining satisfactory warranty service, call <b>1-888-865-3026</b> .<br>You must provide the model number, serial number and date of purchase or date of original installation. |

For Customer Support/Service, please call:

**1-888-865-3026**

**[www.lg.com/us/business](http://www.lg.com/us/business)**



Pro:Centric, the "Pro:Centric" logo, and the "LG" logo are registered trademarks of LG Electronics Inc. Pro:Idiom is a registered trademark of Zenith Electronics LLC. All other trademarks or registered trademarks are the property of their respective owners.

