



OWNER'S MANUAL

AIR CONDITIONER



Read this owner's manual thoroughly before operating the appliance and keep it handy for reference at all times.

TYPE: ROOM AIR CONDITIONER

ENGLISH ESPAÑOL FRANÇAIS



MFL67646805
Rev.06_081321

www.lg.com

<http://www.lghvac.com>

Copyright © 2020 - 2021 LG Electronics Inc. All Rights Reserved.

TABLE OF CONTENTS

3 SAFETY INSTRUCTIONS

3 IMPORTANT SAFETY INSTRUCTIONS

7 PRODUCT OVERVIEW

9 PREPARING FOR INSTALLATION

9 Contents of Installation Kit

9 Tools and Materials Needed

10 INSTALLATION

10 How to Install the Unit

11 How to connect power supply cord

12 Disassembly Instructions

12 Electrical Data

14 Electrical Safety

15 Subbase (Optional)

17 OPERATION

17 Before Operation

18 Manual Controls

19 Control Panel

20 Additional Controls

25 Self-Diagnosis

27 SMART FUNCTIONS

27 LG ThinQ Application

29 Smart Diagnosis

30 MAINTENANCE

30 Air Filter

31 Vent Filter

32 Unit

32 Compressor and Fan Motor

32 Front Grille

33 TROUBLESHOOTING

33 Before Calling for Service

33 Normal Sounds You May Hear

36 WARRANTY(USA)

37 WARRANTY(CANADA)

SAFETY INSTRUCTIONS

READ ALL INSTRUCTIONS BEFORE USE

Your safety and the safety of others are very important.

We have provided many important safety instructions in this manual and on your appliance. Always read and follow all safety instructions.



This is the safety alert symbol.

This symbol alerts you to potential hazards that can kill or injure you and others. All safety instructions will follow the safety alert symbol and either the word WARNING or CAUTION.

These words mean:



WARNING

You may be killed or seriously injured if you do not follow instructions.



CAUTION

You may be injured or cause damage to the product if you do not follow instructions.

All safety instructions will tell you what the potential hazard is, tell you how to reduce the chance of injury, and tell you what may happen if the instructions are not followed.

IMPORTANT SAFETY INSTRUCTIONS



WARNING

To reduce the risk of explosion, fire, death, electric shock, scalding or injury to persons when using this product, follow basic precautions, including the following:

California Proposition 65

- This product contains chemicals known to the State of California to cause cancer and birth defects or other reproductive harm. Wash hands after handling.

INSTALLATION

- Before use, the appliance must be properly installed as described in this manual.
- Contact the authorized service technician for repair or maintenance of this unit.
- Contact the installer for installation of this unit.
- When the power cord is to be replaced, replacement work shall be performed by authorized personnel only using only genuine replacement parts.
- Installation work must be performed in accordance with the National Electric Code by qualified and authorized personnel only.
- Connect to a properly rated, protected, and sized power circuit to avoid electrical overload.

- Always plug into a grounded outlet.
- Do not under any circumstances, cut or remove the third (ground) prong from the power cord.
- When installing or moving the appliance, be careful not to pinch, crush, or damage the power cord.
- Plug in the power plug properly.
- Do not modify or extend the power cord.
- Do not start/stop operation by plugging/unplugging the power cord.
- If the cord/plug is damaged, have it replaced by an authorized service person using authorized replacement parts.
- Use a dedicated circuit.
- Do not disassemble or modify the product.
- Adhere to all industry recommended safety procedures including the use of long-sleeved gloves and safety glasses.
- Use care when unpacking and installing. The edges of the product may be sharp.
- Disconnect the power cord or circuit breaker before installing or servicing the appliance.
- Keep packaging materials out of the reach of children. These materials can pose a suffocation risk to children.
- Store and install the product where it will not be exposed to temperatures below freezing or exposed to outdoor weather conditions.
- Do not store or use gasoline or other flammable vapors and liquids in the vicinity of this or any other appliance.
- Do not install the unit in potentially explosive atmospheres.

OPERATION

- The air conditioner is not intended for use by young children or invalids without supervision.
- Young children should be supervised to ensure that they do not play with the air conditioner.
- Use this appliance only for its intended purpose.
- Never attempt to operate this appliance if it is damaged, malfunctioning, partially disassembled, or has missing or broken parts, including a damaged cord or plug.
- Repair or immediately replace all power cords that have become frayed or otherwise damaged.
- Do not use a cord that shows cracks or abrasion damage along its length or at either end.
- Do not run cord under carpets or mats where it could be stepped on and damaged.
- Keep the cord out from under heavy objects like tables or chairs.
- Do not place the power cord near a heat source.
- Do not use an adaptor or plug the product into a shared outlet.
- Do not tamper with controls.
- If you detect a strange sound, a chemical or burning smell, or smoke coming from the appliance, unplug it immediately, and contact an LG Electronics Customer Information Center.

- Never unplug the appliance by pulling on the power cord. Always grip the plug firmly and pull straight out from the outlet.
- Do not grasp the power cord or touch the appliance controls with wet hands.
- If water enters the product, turn off the power at the main circuit, then unplug the product and call for service.
- If the product has been submerged, contact an LG Electronics Customer Information Center for instructions before resuming use.
- Unplug the product when unused for long periods.
- Unplug the product before cleaning.
- In the event of a gas leak (propane gas, etc.) do not operate this or any other appliance. Open a window or door to ventilate the area immediately.
- This appliance is not intended for use by persons (including children) with reduced physical, sensory or mental capabilities, or lack of experience and knowledge, unless they have been given supervision or instruction concerning the use of the appliance by a person responsible for their safety.
- The interior of the product must only be cleaned by an authorized service center or a dealer.
- Do not use solvent-based detergent on the product. Doing so can cause corrosion or damage, product failure, electrical shock, or fire.

GROUNDING INSTRUCTIONS

- The power cord of this appliance is equipped with a three-prong (grounding) plug. Use this with a standard three-slot (grounding) wall power outlet to minimize the hazard of electric shock. The customer should have the wall receptacle and circuit checked by a qualified electrician to make sure the receptacle is properly grounded.
DO NOT CUT OR REMOVE THE THIRD (GROUND) PRONG FROM THE POWER PLUG.
 - Situations when the appliance will be disconnected occasionally; Because of potential safety hazards, we strongly discourage the use of an adapter plug. However, if you wish to use an adapter, a TEMPORARY CONNECTION may be made. Use UL-listed adapter, available from most local hardware stores. The large slot in the adapter must be aligned with the large slot in the receptacle to assure a proper polarity connection.
- Attaching the adapter ground terminal to the wall receptacle cover screw does not ground the appliance unless the cover screw is metal, and not insulated, and the wall receptacle is grounded through the house wiring. The customer should have the circuit checked by a qualified electrician to make sure the receptacle is properly grounded.
- Disconnect the power cord from the adapter, using one hand on each. Otherwise, the adapter ground terminal might break. Do not use the appliance with a broken adapter plug.
 - Situations when the appliance will be disconnected often; Do not use an adapter plug in these situations. Unplugging the power cord frequently can lead to an eventual breakage of the ground terminal. The wall power outlet should be replaced by a three-slot (grounding) outlet instead.

CAUTION

To reduce the risk of minor or moderate injury to persons, malfunction, or damage to the product or property when using this product, follow basic precautions, including the following:

INSTALLATION

- Take care when installing the product that exhaust or condensation does not damage nearby property.
- Follow installation instructions exactly to avoid excessive vibration or water leakage.
- Aluminum building wiring may present special problems—consult a qualified electrician.

OPERATION

- This appliance is not intended for use as a precision refrigeration system. Do not use it for special purposes such as maintaining pets, food, precision machinery, or art objects.
- When installing or moving the appliance, be careful not to pinch, crush, or damage the power cord.
- Make sure the air inlet and outlet are free from obstructions.
- Use a soft cloth to clean the appliance. Do not use waxes, thinners, or harsh detergents.
- Do not step on or place heavy objects on top of the appliance.
- Do not operate the appliance without the filter securely installed.
- Do not drink water drained from the appliance.
- Be sure to ventilate sufficiently when the air conditioner and a heating appliance such as a heater are used simultaneously.
- Being exposed to direct airflow for an extended period of time could be hazardous to your health.
- Do not expose people, animals, or plants to the cold or hot wind from the air conditioner for extended periods of time.

MAINTENANCE

- Clean the filter every two weeks.
- Never touch the metal parts of the air conditioner when removing the air filter.
- Never use strong cleaning agents or solvents when cleaning the air conditioner or spray water.
Use a smooth cloth.

PRODUCT OVERVIEW

⚠ WARNING

- This air conditioner should be installed in accordance with the National Electric Code. Expanded Metal Grille Should be applied for better performance in PTAC and PTHP Units. For Installation purpose and better appearance Aluminum Rear Grille or Architecture Rear Grille can be applied in PTAC and PTHP Units.

ENGLISH

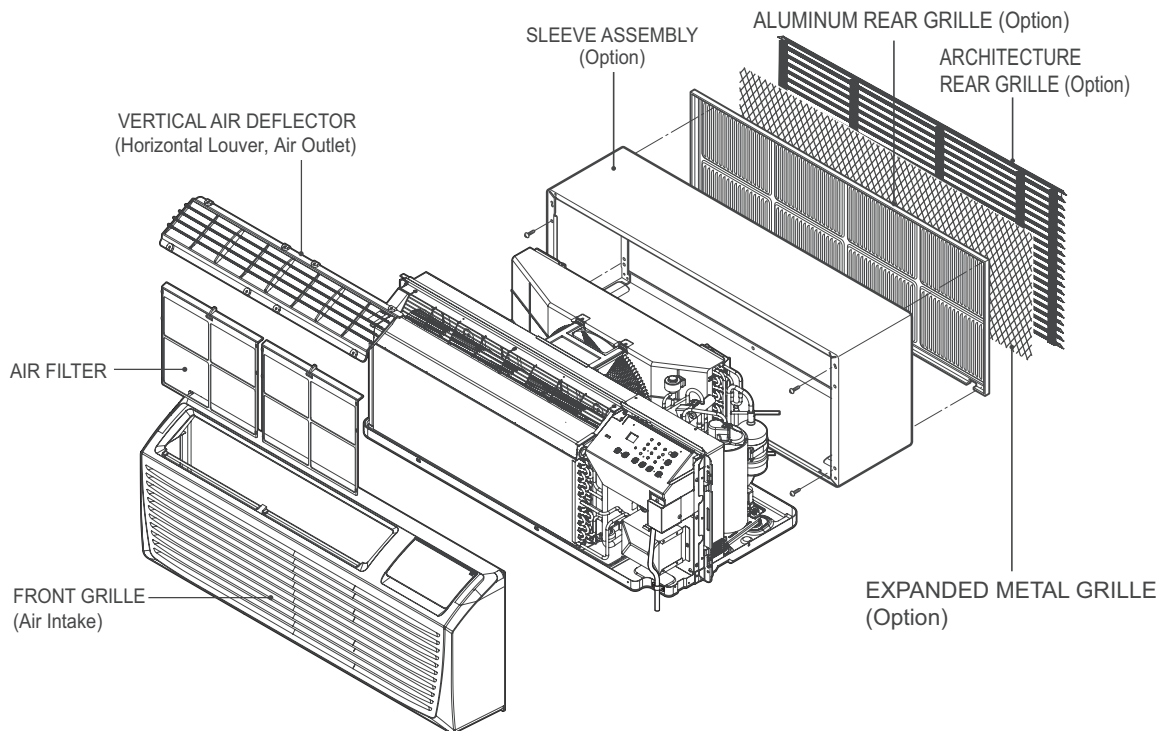

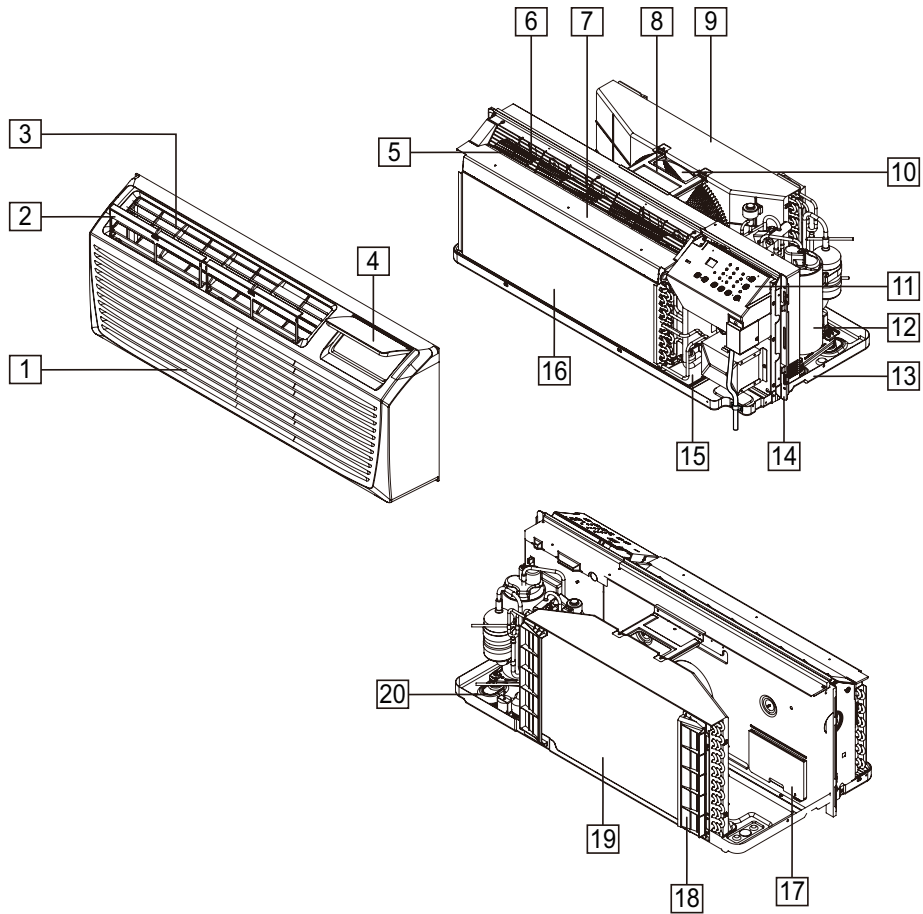

1 Front Grille

2 Air Filter

3 Discharge Grill

4 Door

5 Mesh, Metal

6 Fan

7 Cover

8 Brace

9 Shroud

10 Fan

11 Control Box

12 Compressor

13 Base pan

14 Bracket

15 Pan drain

16 Evaporator

17 Vent Door

18 Rear,Grille

19 Condenser

20 Valve, Drain

PREPARING FOR INSTALLATION

Contents of Installation Kit

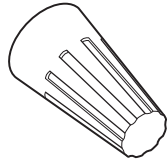

Wire Nuts
(7)

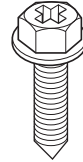

Screws
(6)

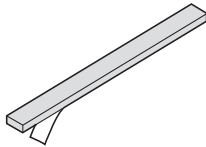

Insulation Strip

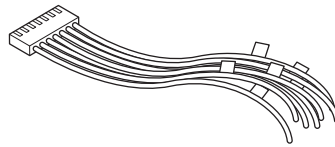

Wall thermostat harness

Tools and Materials Needed



Phillips-head
screwdriver



Utility Knife

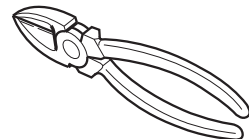

Nipper pliers

INSTALLATION

How to Install the Unit

- 1 Measure the wall sleeve and air conditioner dimensions.
You can install the new air conditioner according to these installation instructions to achieve the best performance. All wall sleeves used to mount the new air conditioner must be in good structural condition and have the rear grille(sold separately) that securely gets attached to the sleeve or the flange of the sleeve to secure the new air conditioner.

Dimension of air conditioner

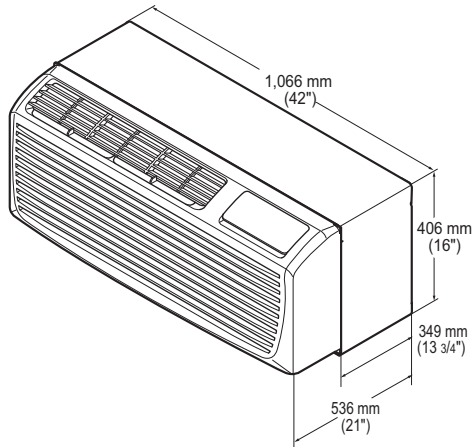

Dimension of sleeve assembly (optional)

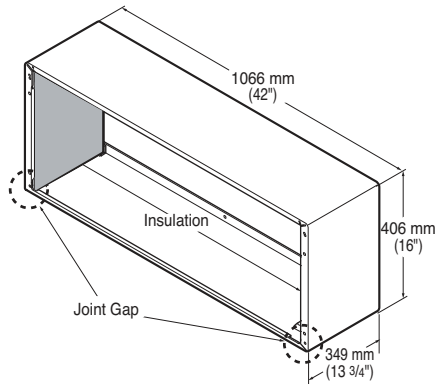

- 2 To avoid vibration and noise, make sure the unit is installed securely and firmly.
- 3 When installing the sleeve & Front grille, make certain there is nothing within 21" back & front of sleeve & front grille, that would interfere with heat radiation and exhaust air flow.
- 4 An insulation strip must be attached.

The insulation strip is provided with the box.

- 5 After assembly of sleeve & front grille, the gap should be over 20" from both sleeve & grille. (See the figure 1.)

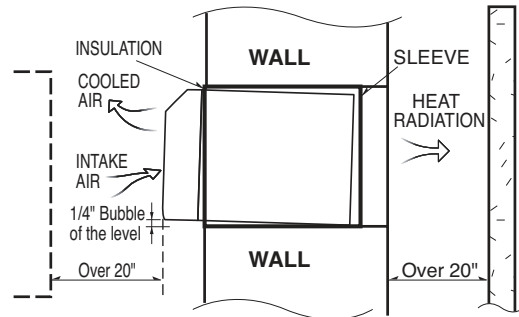
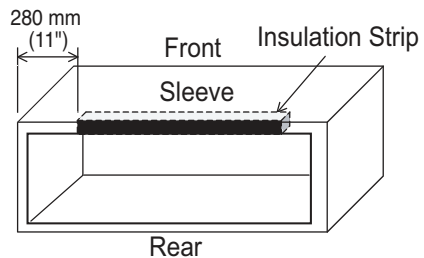

Figure 1

- 6 Take out the insulation strip from the upper packing.
- 7 Attach the insulation strip onto the rear upper side of the wall sleeve.



CAUTION

- Require 2 people to lift the air conditioner, it is HEAVY
- Before installation, Check the insulation on the inner side of the sleeve. If there is no insulation, place the insulation.
- Check the bottom corner's joint gap of the sleeve, If there is, fill the gap with putty.

How to connect power supply cord

- 1 Remove the front grille by pulling it out at the bottom to release it, then lift it up along the unit top front.

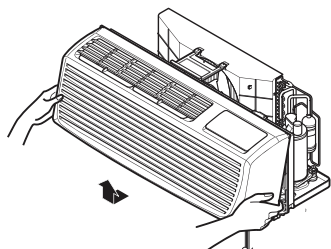

- 2 Remove cover by removing 2 screws from front.

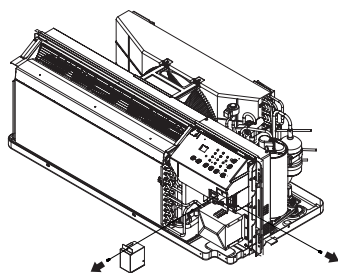

- 3 Connect accessory power supply cord, and attach power cord to base pan with screws.

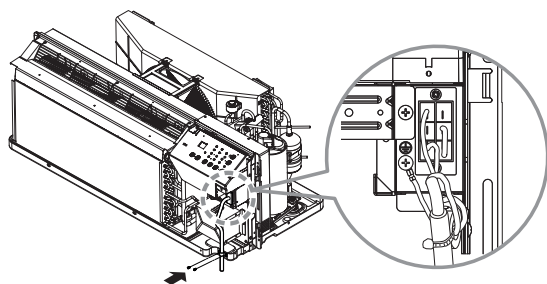

* You need to attach ground wire to cover with a ground screw.

- 4 Replace cover with screws. Tighten securely.

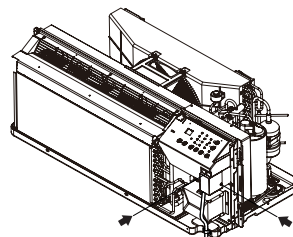

- 5 Slide the unit into the wall sleeve and secure with 4 screws through the unit flange holes.

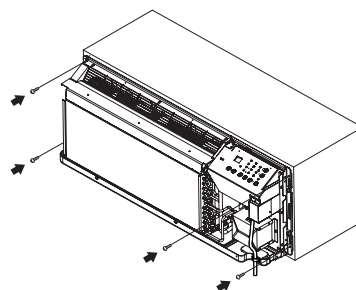

- 6 Reinstall the front grille by hooking the top over the unit top, then pushing it in at the bottom.

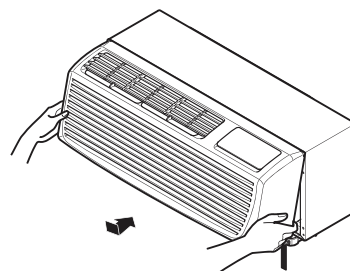

ELECTRIC HEATER RATING (CONFIGURATION BASED ON POWER CORD)

| POWER CORD | VOLTAGE | HEATER WATTS | HEATER CURRENT | MAX. FUSE SIZE | MIN. CIRCUIT AM-PACITY |
|------------|-----------|---------------|----------------|----------------|------------------------|
| AYUH2315 | 230/208 V | 2 000/1 650 W | 9.2/8.4 A | 15 A | 11.9 A |
| AYUH2320 | 230/208 V | 3 000/2 450 W | 13.5/12.3 A | 20 A | 17.2 A |
| AYUH2330 | 230/208 V | 5 000/4 000 W | 22.1/20.2 A | 30 A | 28.0 A |

Disassembly Instructions

Front grille

- 1 To remove the front grille, pull out the bottom of the front grille and then lift up.
Re-install the component by referring to the removal procedure.
- 2 To reinstall the front grille, place the tabs over the top of the unit and push the bottom of front grille until the clips snap into place.

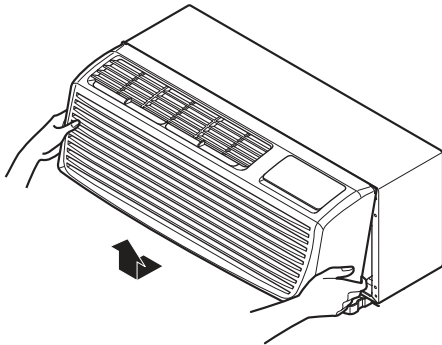

Angle of discharge grille louvers

- This Room Air Conditioner (PTAC) discharges air from the top of the unit through reversible, 2-position discharge grille louvers. The unit is shipped from the factory with the discharge grille louvers at an angle of 40° off vertical. In an alternate position the louvers will be at an angle of 15° off vertical.

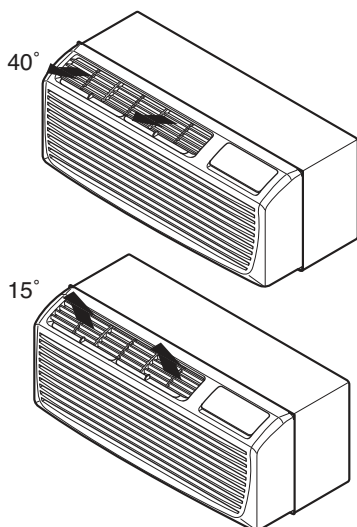

- To adjust the air direction, remove the front grille. Remove the 4 screws that fasten the discharge grille to the front grille. Rotate the discharge grille 180°, then assembly the discharge grille to the front grille with 4 screws.

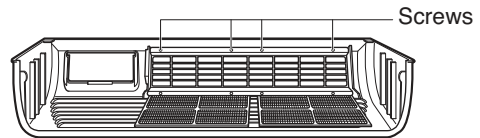

⚠ WARNING

- Before the following disassembly, **POWER SWITCH** is set to **OFF** and disconnected the power cord.

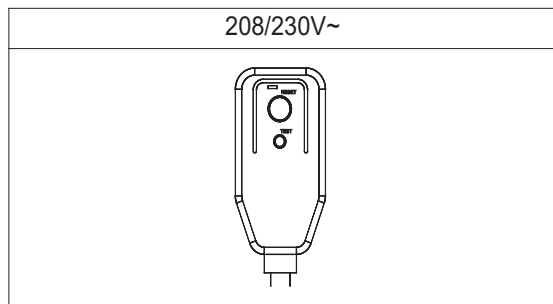

Electrical Data

Power cord may include a current interrupter device. **TEST** and **RESET** buttons are provided on the plug case. The device should be tested on a periodic basis by first pressing the **TEST** button and then the **RESET** button. If the **TEST** button does not trip or if the **RESET** button will not stay engaged, discontinue use of the air conditioner and contact a qualified service technician.



NOTICE

The shape may be different according to its model.

| Use Wall Receptacle | Power Supply | Applied Model |
|---|---|---|
|  <p>Standard 208/230V, 3-wire grounding receptacle rated 15A</p> | Use 15 AMP. time delay fuse or 15 AMP. Circuit breaker. | LP073IHP.AK3GEUS, LP093IHP.AK3GEUS, LP123IHP.AK3GEUS, LP153IHP.AK3GEUS |
|  <p>Standard 208/230V, 3-wire grounding receptacle rated 20A</p> | Use 20 AMP. time delay fuse or 20 AMP. Circuit breaker. | |
|  <p>Standard 208/230V, 3-wire grounding receptacle rated 30A</p> | Use 30 AMP. time delay fuse or 30 AMP. Circuit breaker. | |

⚠ WARNING

- This appliance should be installed in accordance with the National Electrical Code.
- Use of extension cords could cause serious injury or death.
- Do not use an extension cord with this air conditioner.
- Do not use surge protectors or multi-outlet adapters with this air conditioner.
- Never push the **TEST** button during operation. Doing so can damage the plug.
- Do not remove, modify, or immerse this plug. If this device trips, the cause should be corrected before further use.

⚠ CAUTION

- The conductors inside this cord are surrounded by shields, which monitor leakage current. These shields are not grounded. Periodically examine the cord for any damage. Do not use this product in the event the shields become exposed.
- Avoid shock hazard. This unit cannot be user-serviced. Do not open the tamper resistant sealed portion. All warranties and performance will be voided. This unit is not intended to be used as an ON/OFF unit.

NOTICE

DO NOT USE AN EXTENSION CORD on 208/230 Volt units.
 All wiring should be made in accordance with local electrical codes and regulations.
 Aluminum house wiring may pose special problems. Consult a qualified electrician.

Electrical Safety

IMPORTANT

(PLEASE READ CAREFULLY)

FOR THE USER'S PERSONAL SAFETY, THIS APPLIANCE MUST BE PROPERLY GROUNDED

The power cord(sold separately) of this appliance is equipped with a three-prong (grounding) plug. Use this with a standard three-slot (grounding) wall power outlet to minimize the hazard of electric shock. The customer should have the wall receptacle and circuit checked by a qualified electrician to make sure the receptacle is properly grounded.

DO NOT CUT OR REMOVE THE THIRD (GROUND) PRONG FROM THE POWER PLUG.

A. SITUATIONS WHEN THE APPLIANCE WILL BE DISCONNECTED OCCASIONALLY

Because of potential safety hazards, we strongly discourage the use of an adapter plug. However, if you wish to use an adapter, a TEMPORARY CONNECTION may be made. Use UL-listed adapter, available from most local hardware stores. The large slot in the adapter must be aligned with the large slot in the receptacle to assure a proper polarity connection.

CAUTION

- Attaching the adapter ground terminal to the wall receptacle cover screw does not ground the appliance unless the cover screw is metal, and not insulated, and the wall receptacle is grounded through the house wiring. The customer should have the circuit checked by a qualified electrician to make sure the receptacle is properly grounded.

Disconnect the power cord from the adapter, using one hand on each. Otherwise, the adapter ground terminal might break. DO NOT USE the appliance with a broken adapter plug.

B. SITUATIONS WHEN THE APPLIANCE WILL BE DISCONNECTED OFTEN

Do not use an adapter plug in these situations. Unplugging the power cord frequently can lead to an eventual breakage of the ground terminal. The wall power outlet should be replaced by a three-slot (grounding) outlet instead.

USE OF EXTENSION CORDS

Because of potential safety hazards, we strongly discourage the use of an extension cord. However, if you wish to use an extension cord, use a CSA certified/UL-listed 3-wire (grounding) extension cord.

Subbase (Optional)

The Subbase provides an enclosure for an electrical receptacle, power switch and a circuit breaker. Electrical connections to the power supply from the unit are made inside the subbase. In addition, the subbase provides structural support to the Wall Sleeve and to the weight of the PTAC unit .

The Subbase kit consists of two leveling legs for sleeve support and an accurate unit for leveling during installation. Also, the subbase is pre-wired and is grounded by means of a grounding screw.

Part No.: AYSB1201B Subbase - 208/230V 20A w/o DS
 AYSB1301B Subbase - 208/230V 30A w/o DS
 AYSB5101 Subbase Panel
 AYSB6101 Subbase - Non Electrical

Notes :

w/o DS --> without disconnect switch

w/ DS --> with disconnect switch

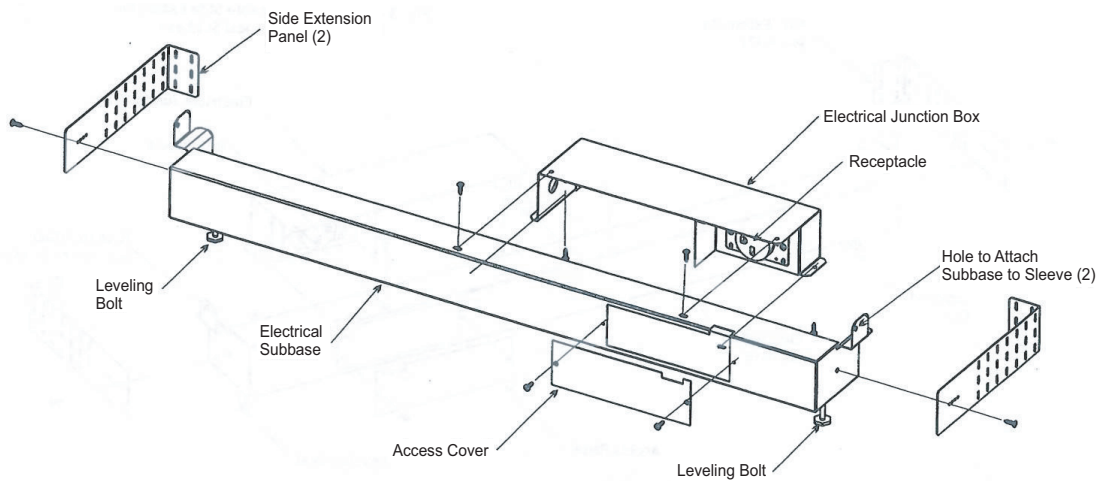

NOTE

When using a subbase, the wall sleeve must be installed at a minimum height of 3 – 1/4 inches (83mm) above a finished floor and at a minimum distance of 2 – 3/4 inches(70mm) from a finished wall.

Installation Procedure:

1. Disconnect all power to unit.
2. Mark the hole location on sleeve then drill 1/8in holes. See Figure 2 for hole dimensions on sleeve.
3. (Optional) Adjustable side extension panels can be attached to cover open space left between subbase and wall.
4. Attach side extension panels to subbase using one black screw on each side so that panel end extends dimensions from the subbase.
5. Bring power into the subbase electrical junction box using one of the knockouts for conduit connections.

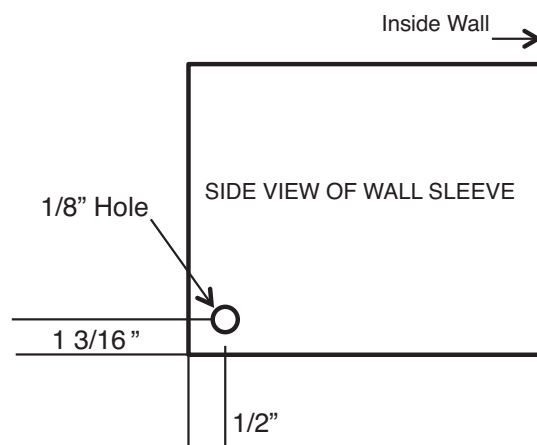

Figure 2

6. Take electrical junction box cover off and use field supplied wire nuts to connect power to receptacle wires. See Figure 3.

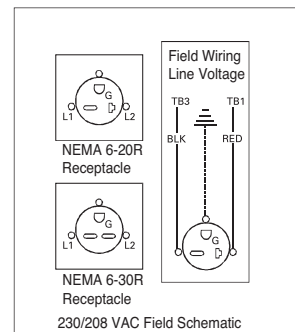

Figure 3

7. Attach subbase to wall sleeve. Subbase has side tabs for mounting the subbase to sleeve. Be sure hole on the side tab is lined up with the pre drilled hole on side of sleeve. Once holes are aligned, attach subbase to sleeve with one screw on each side. See Figure 4.
8. Level subbase flush with floor by adjusting leveling bolts beneath each end of subbase.
9. Remove the access cover from the subbase and plug the power cord into receptacle. Route power cord out of subbase through cord notch in subbase.
10. Restore power to unit.

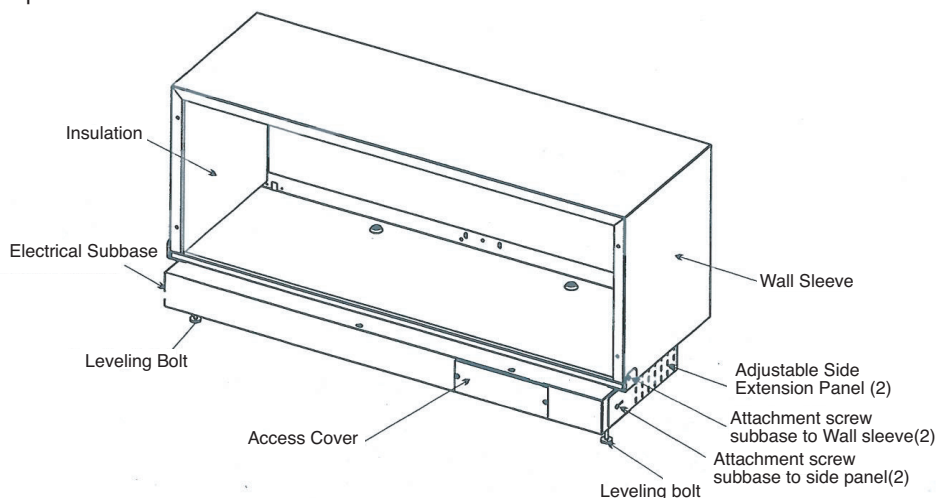

Figure 4

OPERATION

Before Operation

Preparing for Operation

- Contact an installation specialist for installation. This is NOT a do-it-yourself project.
- Plug in the power plug properly.
- Use a dedicated circuit.
- Do not use an extension cord. Consult a professional installer or electrician.
- Do not start/stop operation by plugging/unplugging the power cord.
- If the cord/plug is damaged, replace it with only an authorized replacement part.

Usage

- Being exposed to direct airflow for an extended period of time could be hazardous to your health. Do not expose occupants, pets, or plants to direct airflow for extended periods of time. In other words, don't sit in the draft.
- Due to the possibility of oxygen deficiency, ventilate the room when used together with stoves or other heating devices.
- Do not use this air conditioner for non-specified special purposes (e.g. preserving precision devices, food, pets, plants, and art objects). Such usage could damage the items.

Cleaning and Maintenance

- Do not touch the metal parts of the unit when removing the filter. Injuries can occur when handling sharp metal edges.
- Do not use water to clean inside the air conditioner. Exposure to water can destroy the insulation, leading to possible electric shock.
- When cleaning the unit, first make sure that the power and breaker are turned off. The fan rotates at a very high speed during operation. There is a possibility of injury if the unit's power is accidentally triggered on while cleaning inner parts of the unit.

Service

For repair and maintenance, contact your authorized service dealer.

Manual Controls

VENTILATION

To use ventilation door, remove the screw which fasten the ventilation door.(See Figure 5)

The ventilation lever is located to the upper right side of the unit.

The ventilation lever must be in the CLOSE position in order to maintain the best cooling & heating conditions.

When outdoor air is necessary in the room, set the ventilation lever to the OPEN position.

The Ventilation door is opened and outdoor air is drawn into the room.

This will reduce the cooling or heating efficiency.

NOTE

This effect will reduce the cooling or heating efficiency. In order to work correctly, installer or customer will have to remove glass or panels to better exhaust hot air.

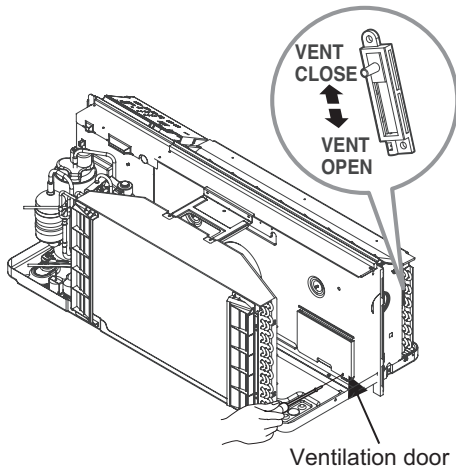
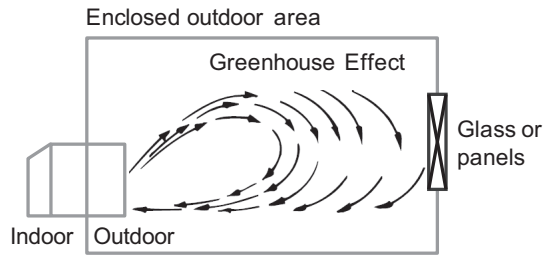

Figure 5

CAUTION

- PTAC exhausting discharge air in balcony that is closed off with glass or panels. This causes hot air to be pulled back into the fresh air intake.



CAUTION

- Failure to follow this caution may result in equipment damage or improper operation.
- Blocking indoor (curtain or bedclothes etc.) or outdoor discharge air could cause premature failure of unit.
- If there has a gap between rear side of product & outside wall, the air splitter need to be used on unit.

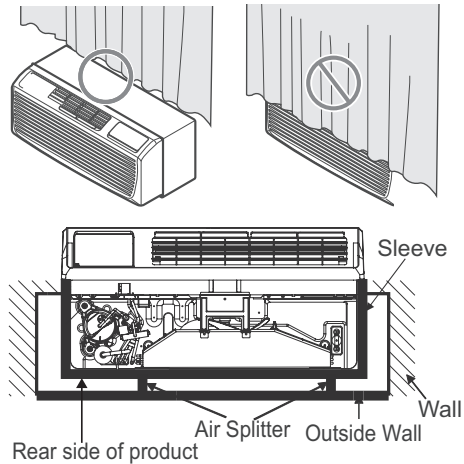

CAUTION





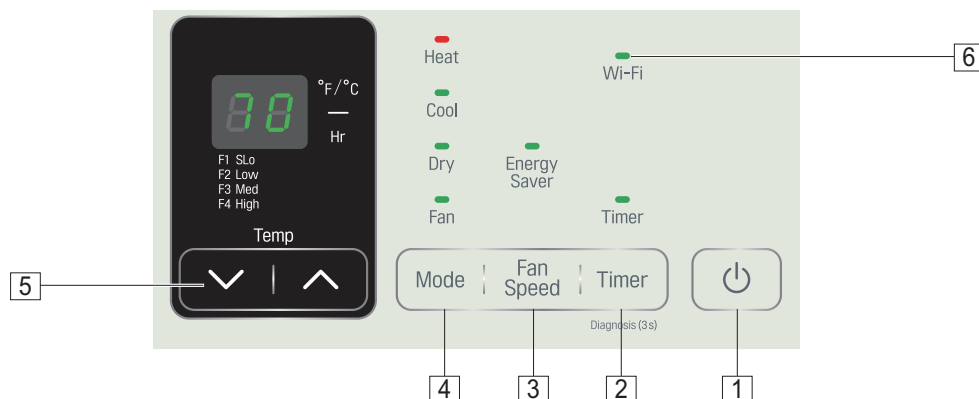

- When the air conditioner has been running and is turned off or set to the fan position, wait at least 3 minutes before resetting to the cooling & heating operations.

NOTE

A slight heat odor may come from the unit when first switching to HEAT after the cooling season is over. This odor, caused by fine dust particles on the heater, will disappear quickly. This is harmless.

Control Panel



- 1 Power**
Press to turn the air conditioner ON or OFF.
 - 2 Delay ON/OFF Timer**
Delay ON - When the air conditioner is off, set it to automatically turn on from 1 to 24 hours later, at its previous mode and fan settings.
Delay OFF - When the air conditioner is on, set it to automatically turn off from 1 to 24 hours later.
NOTE
 • Each press of the **Timer** button advances the timer by 1 hour. After the last press the display returns to the temperature setting.
 - 3 Fan Speed**
Press to set the fan speed to SLo(F1), Low(F2), Med(F3), High(F4). It cycles through the settings as follows: {High(F4) → Med(F3) → Low(F2) → SLo(F1) → High(F4)}
 - 4 Operation Mode**
Press the Mode button to cycle between 4 types of air conditioner operation: Heat / Cool / Fan / Dry
Heat - This mode is ideal on cold days to warm the room quickly. Use the **Temp**   buttons to set the desired room temperature and use the **Fan Speed** button to set the desired fan circulation speed.
Cool - This mode is ideal on hot days to cool and dehumidify the room quickly. Use the **Temp**   buttons to set the desired room temperature and use the **Fan Speed** button to set the desired fan circulation speed.
Fan - In this mode the fan circulates air but the compressor does not run. Use the **Fan Speed**
- button to set fan speed to High, Medium, Low or Slow. In this mode, you cannot adjust the set temperature.
- Dry** - This mode is ideal for rainy and damp days to dehumidify the room rather than cooling it significantly. Moisture is removed from the room by the combination of compressor operation and the fan speed fixed at Low. The compressor and fan turn off once the set temperature is reached. Fan speed cannot be adjusted in Dry mode.
- 5 Temperature Control**
The thermostat monitors room temperature to maintain the desired temperature. The thermostat can be set between 54°F - 86°F (12.2°C - 30°C) in cool/heat mode. Press  or  arrows to increase or decrease temperature setting.
 - 6 Wi-Fi**
Enables connection of the air conditioner to the home Wi-Fi. You need to purchase additional accessories to use this mode.



NOTE

- **Auto Restart** : If the air conditioner turns off due to a power outage, it will restart automatically after 3 minutes (time delay) once the power is restored, with the same settings as were set before the unit turned off.
- **Energy Saver** : This mode can be set by digital control. Refer to the 'Digital Controls' section for the setting method.

Additional Controls

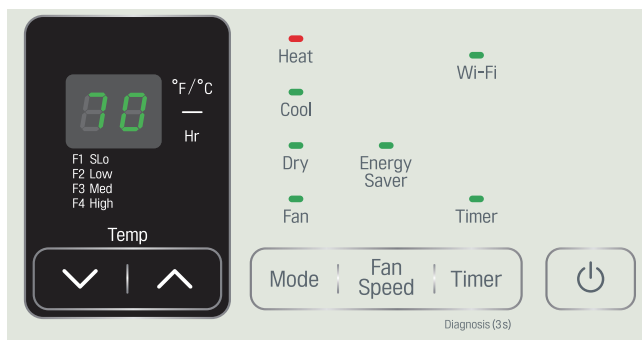
Digital Controls





Simultaneously press this ,  buttons and hold for 3 seconds to enter the setup ready state with the letter dC in the display.

The 1st Digit number is changed sequentially from 1 to 6 when the  button is pressed to select desired setting option.

Select the 2nd digit value through the  |  buttons and set the desired setting value for each option.

Automatically save previous setting value when Option is changed by the  button.

Simultaneously press this ,  buttons and hold for 3 seconds to escape the function. (Display phase temperature during normal escape)

※ Escape automatically when no button is pressed for 3 minutes.

| | | | | | |
|----------------------------|---|---|--|---------------------------|-----------------|
| Control Type | 1 | 0 | Local/Wifi, LG Exclusive Wired Remote Controller(option) | | Default setting |
| | | 1 | Remote | | |
| Energy Saver | 2 | 0 | Off | | Default setting |
| | | 1 | On | | |
| Temperature Display | 3 | 0 | Fahrenheit | | Default setting |
| | | 1 | Celsius | | |
| | | | Cooling | Heating | |
| Temperature Limit | 4 | 0 | 54°F(12.2°C)~86°F(30.0°C) | 54°F(12.2°C)~86°F(30.0°C) | Default setting |
| | | 1 | 56°F(13.3°C)~86°F(30.0°C) | 54°F(12.2°C)~84°F(28.9°C) | |
| | | 2 | 58°F(14.4°C)~86°F(30.0°C) | 54°F(12.2°C)~82°F(27.8°C) | |
| | | 3 | 60°F(15.5°C)~86°F(30.0°C) | 54°F(12.2°C)~80°F(26.7°C) | |
| | | 4 | 62°F(16.6°C)~86°F(30.0°C) | 54°F(12.2°C)~78°F(25.5°C) | |
| | | 5 | 64°F(17.7°C)~86°F(30.0°C) | 54°F(12.2°C)~76°F(24.4°C) | |
| | | 6 | 66°F(18.9°C)~86°F(30.0°C) | 54°F(12.2°C)~74°F(23.3°C) | |
| Unit Type | 5 | 0 | Cooling+Electric Heater+Heat Pump | | Default setting |
| | | 1 | Cooling+Electric Heater | | |
| | | 2 | Cooling Only | | |
| | | 3 | Heat Pump Only | | |
| Make Up Air Mode* (Option) | 6 | 0 | Off | | Default setting |
| | | 1 | On | | |

* Not available on all models.

MODE 1: Control Type

Press MODE until a 1 appears in the first digit of the display for Control type mode.

Remote mode allows the unit to operate by the Remote Wall Thermostat.

The unit control by buttons are not available.

Press the \wedge pad to select Remote.

The default setting for Mode 1 is Local, Wifi and LG Exclusive Wired Remote Controller.



Local/Wifi/LG Exclusive
Wired Remote Controller



Remote

MODE 2: Energy Saver

Press MODE until a 2 appears in the first digit of the display for Energy Saver mode. Energy Saver mode is set at cycle fan to provide continuous fan operation in cool or heat modes.

When Energy Saver mode is off, the continuous fan allows continuous circulation of room air and make the more balanced temperature of the room.

When Energy Saver mode is on, the fan is on or off with the compressor or with the heater.

Press the \wedge pad to turn on Energy Saver mode.

The default setting for Mode 2 is off.



Off



On

MODE 3: Temperature Display

Press MODE until a 3 appears in the first digit of the display for Temperature Display mode. Press the \wedge pad to select Celsius.

The individual will see a °F for Fahrenheit or a °C for Celsius.

The default setting for Mode 3 is Fahrenheit.



Fahrenheit



Celsius

MODE 4: Temperature Limiting

Press MODE until a 4 appears in the first digit of the display for Temperature Limiting mode. Temperature Limiting can save money by limiting the lowest temperature for cooling and the highest temperature for heating. This temperature limiting is not available with the Remote Wall Thermostat.

Press the \vee or \wedge pad to change 2nd Digit number.

| 2nd Digit | Cooling | Heating |
|-----------|---------------------------|---------------------------|
| 0 | 54°F(12.2°C)~86°F(30.0°C) | 54°F(12.2°C)~86°F(30.0°C) |
| 1 | 56°F(13.3°C)~86°F(30.0°C) | 54°F(12.2°C)~84°F(28.9°C) |
| 2 | 58°F(14.4°C)~86°F(30.0°C) | 54°F(12.2°C)~82°F(27.8°C) |
| 3 | 60°F(15.5°C)~86°F(30.0°C) | 54°F(12.2°C)~80°F(26.7°C) |
| 4 | 62°F(16.6°C)~86°F(30.0°C) | 54°F(12.2°C)~78°F(25.5°C) |
| 5 | 64°F(17.7°C)~86°F(30.0°C) | 54°F(12.2°C)~76°F(24.4°C) |
| 6 | 66°F(18.9°C)~86°F(30.0°C) | 54°F(12.2°C)~74°F(23.3°C) |
| 7 | 68°F(20.0°C)~86°F(30.0°C) | 54°F(12.2°C)~72°F(22.2°C) |

The default setting for Mode 4 is as follows:

Cooling : 0{54 °F(12.2 °C)~86 °F(30.0 °C)}
 Heating : 0{54 °F(12.2 °C)~86 °F(30.0 °C)}



Cooling : 0{54 °F(12.2 °C)~86 °F(30.0 °C)}
 Heating : 0{54 °F(12.2 °C)~86 °F(30.0 °C)}



Cooling : 5{64 °F(17.7 °C)~86 °F(30.0 °C)}
 Heating : 5{54 °F(12.2 °C)~76 °F(24.4 °C)}

MODE 5: Unit Type

Press MODE until a 5 appears in the first digit of the display for Unit Type mode.

Press the \vee or \wedge pad to change 2nd Digit number.

The default setting for Mode 5 is Cooling, Electric Heater and Heat Pump type.



Cooling +
Electric Heater +
Heat Pump



Cooling +
Electric Heater



Cooling Only



Heat Pump Only

MODE 6: Make Up Air Mode(Optional)

Press MODE until a 6 appears in the first digit of the display for Make Up Air mode.

Press the \vee or \wedge pad to change 2nd Digit number.

The default setting for Mode 6 is off.



Off



On

Front desk control

When the pair wire is connected to the connector FD2 and FD1, the unit can be turned ON or OFF with a switch located at the Front Desk Control panel. When the front desk switch is ON, the fan operates according to the setting without working compressor and heater. When the front desk switch is OFF, the unit can operate according to the setting of controls.

| Wire # AWG | Maximum Length |
|------------|-----------------|
| #22 | 600 ft (180 m) |
| #20 | 900 ft (270 m) |
| #18 | 1500 ft (450 m) |
| #16 | 2000 ft (610 m) |

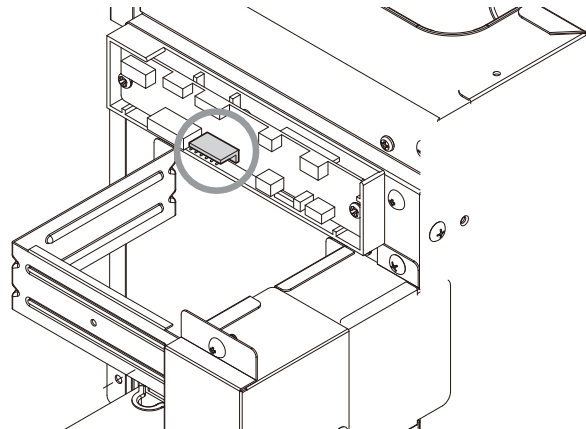
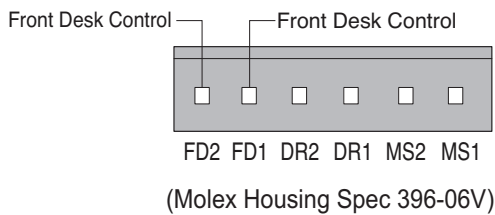

Remote wall thermostat

When the wires are connected, the unit will be controlled by a remote wall thermostat.

The thermostat connections supply the 24 Volt AC.

When you install the digital/electronic thermostat, you must set it to 24 Volt AC.

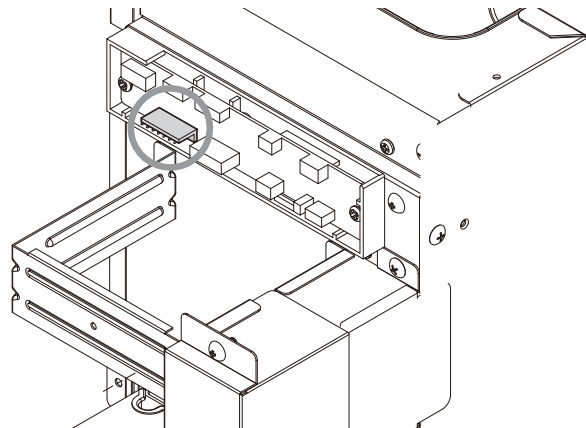
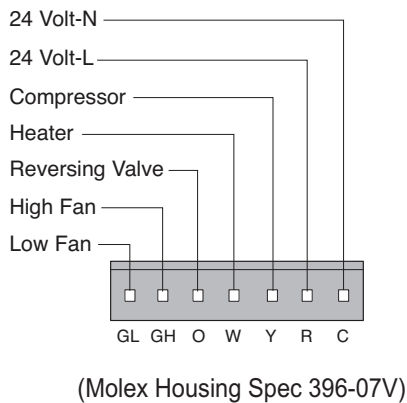

NOTICE

For wiring connection of Wall Thermostat, check the Installation instruction or Installation manual's provided by Thermostat Company.

Simple wired remote controller(optional)

When the cable is connected, the unit will be controlled by a Simple wired remote controller.

You need to purchase additional accessory remote controller to use this unit.(Model : PQRCHCSA)

| | |
|--------|--------|
| Signal | Yellow |
| 12V | Red |
| GND | Black |

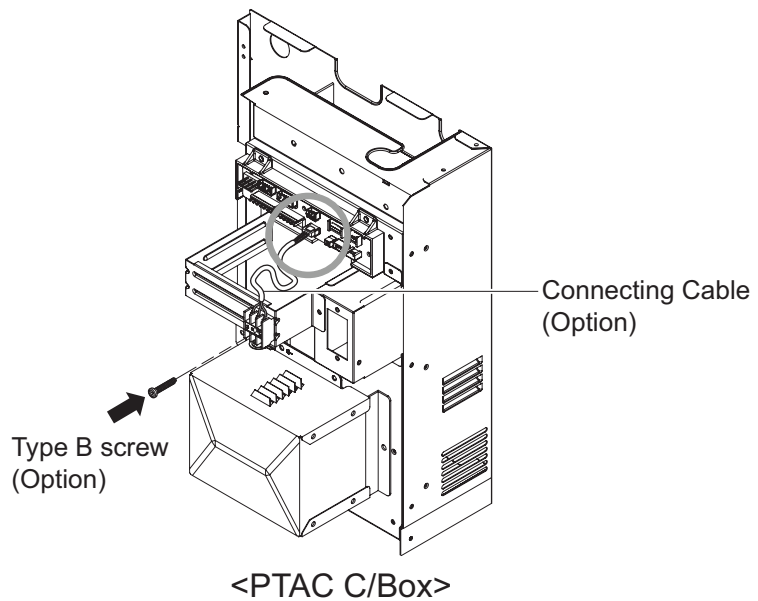
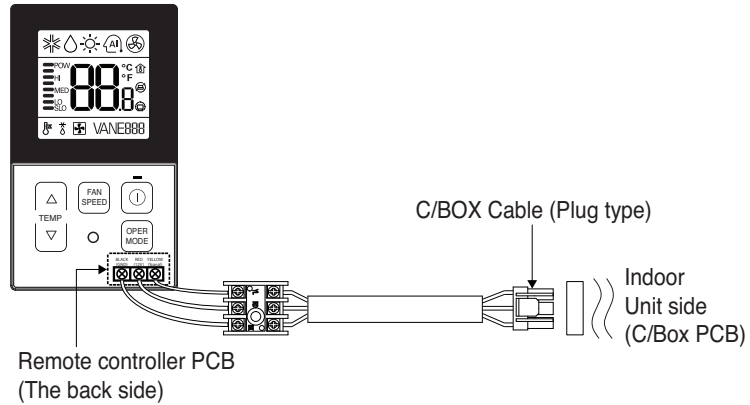

NOTICE

For wiring connection of SIMPLE WIRED REMOTE CONTROLLER, check the Installation instruction or Installation manual's provided by LG company accessory kit.(Model : PQRCHCSA)

Self-Diagnosis

FUNCTION

If the unit has a malfunction, a green OPERATION LED located on the Display PCB used by the unit to indicate the error codes.

USE

If the customer has to register a complaint to the service center, he can be very clear about registering the complaint that what is happening & by referring the user's manual the customer can clearly define the problem.

So that the engineer should go fully prepared with the prescribed tools to be used regarding that problem. It also keeps the customer aware about the unit.



Here are some of the problems defined below for which the LED indicates by flashing.

The error codes are the mentioned which is as follows:

• Electrical Controls

| Error Code | Descriptions |
|------------|---|
| 01 | Indoor unit room temperature sensor error |
| 02 | Indoor unit inlet pipe sensor error |
| 03 | Wired remote control error |
| 05 | Communication error between indoor and outdoor units |
| 07 | Thermostat Wiring Error |
| 09 | Indoor unit EEPROM error |
| 10 | Indoor unit BLDC motor fan lock |
| 21 | DC Peak (IPM Fault) |
| 22 | CT 2 (Max CT) |
| 23 | DC Link Low Volt |
| 26 | DC Comp Position Error |
| 27 | PSC Fault |
| 29 | Comp Phase Over-Current |
| 32 | Inverter Compressor D-Pipe Overheat |
| 36 (38) | Refrigerant Leakage Detection |
| 41 | D-Pipe Sensor Error |
| 44 | Outdoor Air Sensor Error |
| 45 | Cond. Middle Pipe Sensor Error |
| 48 | Cond. Pipe Error (Open / Short) |
| 51 | Excess Capacity (Mismatching between In/Outdoor unit) |
| 53 | Communication Error (IN-OUT) |
| 60 | EEPROM Check Sum Error |
| 61 | Cond. Pipe High |
| 62 | Heat Sink Sensor Temp. High |
| 65 | Heatsink Th Error |
| 67 | BLDC Motor Fan Lock |
| 72 | Detect 4 Way Valve Transfer Failure 7 Times |

NOTICE

| Function | Description | Display code |
|-------------------------|--|---|
| Over heating Protection | This feature prevents over heating of unit by electrical heater located inside of the unit at the remote mode (when the unit is connected with wall thermostat). |  |
| Freeze Protection | This feature prevents freezing of room at low temperature. |  |
| Remote Mode | When use the remote mode operation |  |

SMART FUNCTIONS

LG ThinQ Application

*You need to purchase additional accessory Wifi module to use this function.

This feature is only available on models with the  or **ThinQ** logo.

The **LG ThinQ** application allows you to communicate with the appliance using a smartphone.

LG ThinQ Application Features

Communicate with the appliance from a smartphone using the convenient smart features.

Smart Diagnosis

If you experience a problem while using the appliance, this smart diagnosis feature will help you diagnose the problem.

Settings

Allows you to set various options on the appliance and in the application.

NOTE

- If you change your wireless router, internet service provider, or password, delete the registered appliance from the **LG ThinQ** application and register it again.
- The application is subject to change for appliance improvement purposes without notice to users.
- Functions may vary by model.

Before Using LG ThinQ Application

- 1 Check the distance between the appliance and the wireless router (Wi-Fi network).
 - If the distance between the appliance and the wireless router is too far, the signal strength becomes weak. It may take a long time to register or installation may fail.

- 2 Turn off the **Mobile data** or **Cellular Data** on your smartphone.

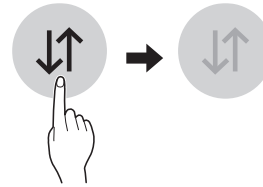

- 3 Connect your smartphone to the wireless router.

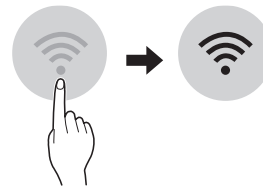

NOTE

- To verify the Wi-Fi connection, check that  icon on the control panel is lit.
- The appliance supports 2.4 GHz Wi-Fi networks only. To check your network frequency, contact your Internet service provider or refer to your wireless router manual.
- **LG ThinQ** is not responsible for any network connection problems or any faults, malfunctions, or errors caused by network connection.
- If the appliance is having trouble connecting to the Wi-Fi network, it may be too far from the router. Purchase a Wi-Fi repeater (range extender) to improve the Wi-Fi signal strength.
- The Wi-Fi connection may not connect or may be interrupted because of the home network environment.
- The network connection may not work properly depending on the Internet service provider.
- The surrounding wireless environment can make the wireless network service run slowly.
- The appliance cannot be registered due to problems with the wireless signal transmission. Unplug the appliance and wait about a minute before trying again.
- If the firewall on your wireless router is enabled, disable the firewall or add an exception to it.
- The wireless network name (SSID) should be a combination of English letters and numbers. (Do not use special characters.)

- Smartphone user interface (UI) may vary depending on the mobile operating system (OS) and the manufacturer.
- If the security protocol of the router is set to **WEP**, you may fail to set up the network. Please change it to other security protocols (**WPA2** is recommended) and register the product again.

Installing the LG ThinQ Application

Search for the **LG ThinQ** application from the Google Play Store or Apple App Store on a smartphone. Follow instructions to download and install the application.

How to connect Wifi Module

- 1 To remove the front grille, pull out the bottom of the front grille and then lift up.

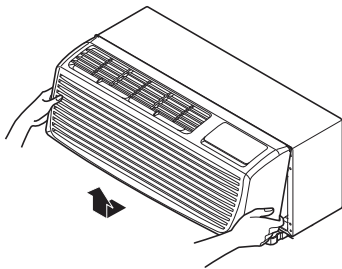

- 2 Remove two covers by removing 4 screws. Connect accessory Wifi module(option) to the Wifi PCB behind Control box panel.

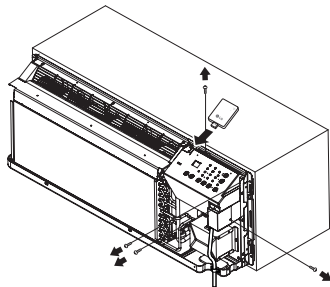

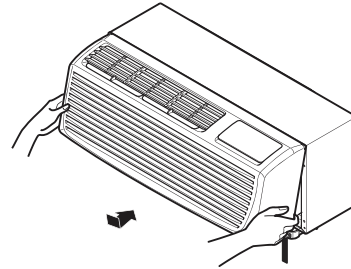

- * You need to purchase additional accessory Wifi module to install this unit.
- * When connecting a Wi-Fi module, insert it in the direction that shows the LG mark.

- 3 Replace two covers with screws. Reinstall the front grille by hooking the top over the unit top, then pushing it in at the bottom.



Smart Diagnosis

This feature is only available on models with the  or  logo.

Use this feature to help you diagnose and solve problems with your appliance.

NOTE

- For reasons not attributable to LGE's negligence, the service may not operate due to external factors such as, but not limited to, Wi-Fi unavailability, Wi-Fi disconnection, local app store policy, or app unavailability.
- The feature may be subject to change without prior notice and may have a different form depending on where you are located.

Using LG ThinQ to Diagnose Issues



If you experience a problem with your Wi-Fi equipped appliance, it can transmit troubleshooting data to a smartphone using the **LG ThinQ** application.

- Launch the **LG ThinQ** application and select the **Smart Diagnosis** feature in the menu. Follow the instructions provided in the **LG ThinQ** application.

Using Audible Diagnosis to Diagnose Issues

Follow the instructions below to use the audible diagnosis method.

- Launch the **LG ThinQ** application and select the **Smart Diagnosis** feature in the menu. Follow the instructions for audible diagnosis provided in the **LG ThinQ** application.

- 1 Plug the power plug in the outlet properly.
- 2 Place the mouthpiece of your smartphone close to the  or  logo.
- 3 Press and hold the **Diagnosis (3 s)** button for 3 seconds or longer while holding the smartphone mouthpiece to the logo until the data transfer is complete.
 - Keep the smartphone in place until the data transfer has finished. Time remaining for data transfer is displayed.
- 4 After the data transfer is complete, the diagnosis will be displayed in the application.

NOTE

- For best results, do not move the phone while the tones are being transmitted.
- Be sure to keep ambient noise to a minimum or the phone may not correctly receive the buzzer beeps from the indoor unit.

MAINTENANCE

⚠ WARNING

- Before cleaning or performing maintenance, disconnect the power supply and wait until the fan stops.

Air Filter

Check the air filter at least twice a month to see if cleaning is necessary. Trapped particles in the filter can build up and block the airflow, reducing cooling capacity and causing an accumulation of frost on the evaporator.

Cleaning the Air Filter

- 1 Remove the air filter from the front grille assembly by pulling the air filter up slightly.

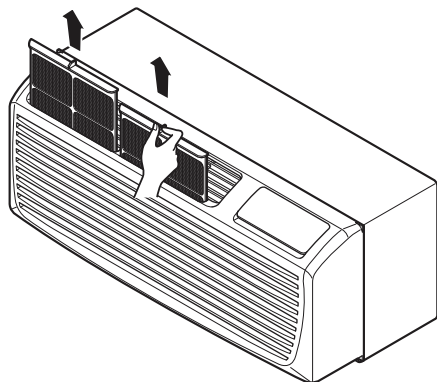

- 2 Wash the filter using lukewarm water below 40 °C (104 °F).

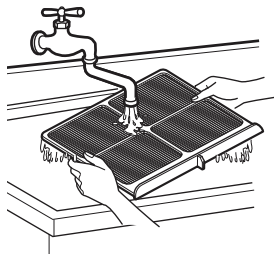

- 3 Gently shake the excess water from the filter and replace.

Cleaning the Front Grille and discharge air grille

- The Front Grille and discharge air grille can be cleaned with a mild soap or detergent. Under no circumstances should hydrocarbon based cleaners (e.g. acetone, benzene, naphtha, gasoline, etc.) be used to clean the front or air grilles.
- Use care when cleaning the control area. Do not use an excessively wet cleaning cloth.

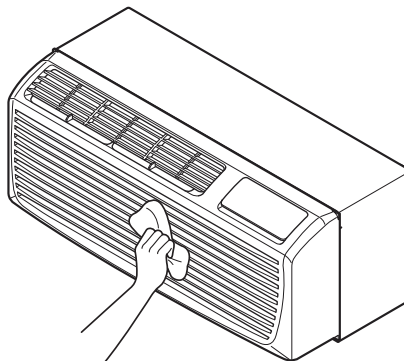

NOTE

- To ensure continued peak efficiency, the condenser coils (outside of unit) should be checked periodically and cleaned if clogged with soot or dirt from outside air.
- For repair and maintenance, contact an Authorized Service Center. 1-888-865-3026(US), 1-855-286-2456(Canada).

Vent Filter

Before cleaning the vent filter, disconnect power to the unit by unplugging the power cord at the wall outlet or subbase, or disconnect power at the fuse box or circuit breaker. If unit is operated with vent door closed, the vent filter does not need to be cleaned.

Cleaning the Vent Filter

- 1 Remove the front grille as described in front grille Removal.

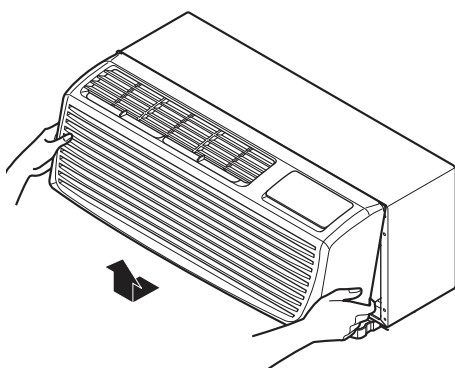

- 2 Remove the 4 screws securing the unit to the wall sleeve with a Phillips-Head screwdriver.

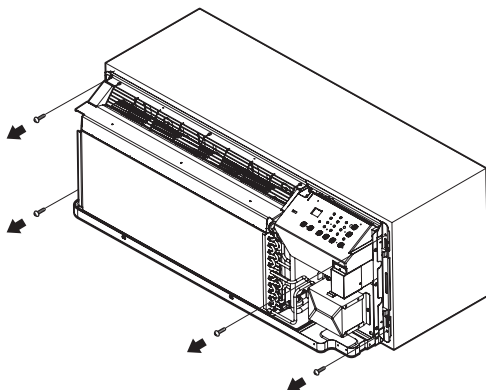

- 3 Slide the unit out of the wall sleeve far enough so that the vent filter is accessible as shown in Figure A. Remove the shipping screw from the ventilation door.

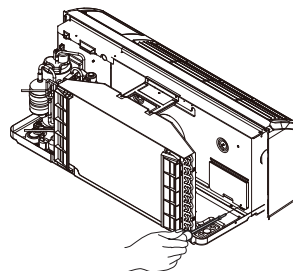

Figure A

- 4 Remove the vent filter by unscrewing the two screws at the top of the filter and gently pulling the filter away from the partition panel. Refer to Figure B.

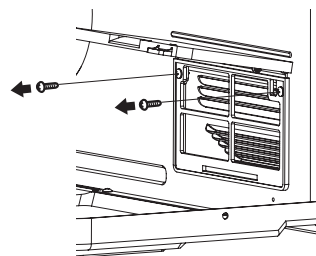
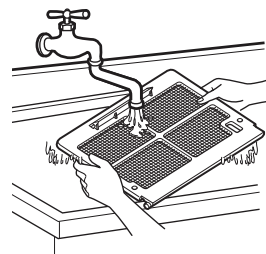

Figure B

- 5 Wash the filter using lukewarm water below 40 °C (104 °F). Reinstall the filter by reattaching the hook to the bottom of the vent door and replacing the two screws, slide the unit back into the wall sleeve, secure it in place with 4 screws and reinstall the front grille.



Unit

The Unit must be cleaned every four months or more often as the atmospheric conditions require. Use water and detergent to clean the base pan and coils. The use of harsh cleaning materials may cause a deterioration of the coil fins or endplates. Do not use a high pressure cleaner as it could cause severe damage to the PTAC fins and coils. A hose is okay to use to clean the coils, but make sure to cover the control with a blanket or plastic bag to keep it dry.

Compressor and Fan Motor

The compressor and fan motor are hermetically sealed, permanently lubricated, and require no additional oiling.

Front Grille

The Front Grille and discharge air grille can be cleaned with a mild soap or detergent. Under no circumstances should hydrocarbon based cleaners (e.g. acetone, benzene, naphtha, gasoline, etc.) be used to clean the front or air grilles. Use care when cleaning the control area. Do not use an excessively wet cleaning cloth.

TROUBLESHOOTING

Before Calling for Service

The appliance is equipped with an automatic error-monitoring system to detect and diagnose problems at an early stage. If the appliance does not function properly or does not function at all, check the following before you call for service.

Normal Sounds You May Hear

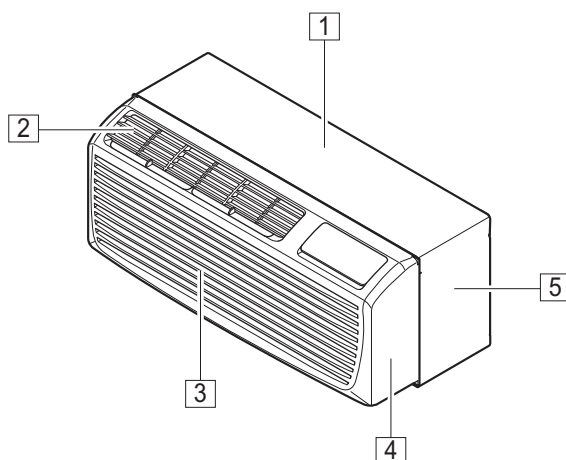

- 1 High Pitched Chatter**
Today's high efficiency compressors may have a high pitched chatter during the cooling cycle.
- 2 Sound of Rushing Air**
At the front of the unit, you may hear the sound of rushing air being moved by the fan.
- 3 Gurgle/Hiss**
Gurgling or hissing noise may be heard due to refrigerant passing through evaporator during normal operation.
- 4 Vibration**
Unit may vibrate and make noise because of poor wall or window construction or incorrect installation.
- 5 Pinging or Swishing**
Droplets of water hitting condenser during normal operation may cause pinging or swishing sounds.

| Problem | Possible Cause | Solutions |
|---|---|--|
| Air conditioner does not start. | The air conditioner is unplugged. | Make sure the air conditioner plug is pushed completely into the outlet. |
| | The fuse is blown/circuit breaker is tripped. | Check the house fuse/circuit breaker box and replace the fuse or reset the breaker. |
| | Power failure. | If power failure occurs, turn the mode control to off. When power is restored, wait 3 minutes to restart the air conditioner to prevent tripping of the compressor overload. |
| | The current interrupter device is tripped. | Press the RESET button located on the power cord plug. If the RESET button will not stay engaged, discontinue use of the air conditioner and contact a qualified service technician. |
| Air conditioner does not cool/heat as it should | Airflow is restricted. | Make sure there are no curtains, blinds, or furniture blocking the front of the air conditioner. |
| | The temp control may not be set correctly. | Set the desired temperature to a level lower or higher than the current temperature. |
| | The air filter is dirty. | Clean the filter at least every 2 weeks. See the 'MAINTENANCE' section. |
| | The room may be cold/hot. | When the air conditioner is first turned on, you need to allow time for the room to heat up/cool down. |
| | Cold air is escaping. | Check for open furnace floor registers and cold air returns. |
| | Hot air is escaping. | Make sure that all vents are closed to air returns. |
| | Cooling coils have iced up. | See 'Air conditioner freezing up' below. |
| Air conditioner freezing up. | The cooling coils are iced over. | Ice may block the air flow and obstruct the air conditioner from properly cooling the room. Set the mode control at High Fan or High Cool. |
| Water drips outside. | Hot, humid weather. | This is normal. |
| Water drips indoors. | The air conditioner is not tilted to the outside. | For proper water disposal, make sure the air conditioner slants slightly from the case front to the rear. |
| Water collects in base pan. | Moisture removed from air and drains into base pan. | This is normal for a short period in areas with little humidity; normal for a longer period in very humid areas. |
| Air conditioner turns on and off rapidly. | Dirty air filter - air restricted. | Clean air filter. |
| | Outside temperature extremely hot. | Set FAN speed to a faster setting to bring air through cooling coils more frequently. |
| Noise when unit is cooling/heating. | Air movement sound. | This is normal. If too loud, set to lower FAN setting. |
| | Window vibration - poor installation. | Refer to installation instructions or check with installer. |
| Room too cold/hot. | Set temperature too low. | Increase set temperature. |
| | Set temperature too high. | Decrease set temperature. |

| Problem | Possible Causes | Solutions |
|---|--|---|
| Your home appliance and smartphone is not connected to the Wi-Fi network. | The password for the Wi-Fi that you are trying to connect to is incorrect. | Find the Wi-Fi network connected to your smartphone and remove it, then register your appliance on LG ThinQ. |
| | Mobile data for your smartphone is turned on. | Turn off the Mobile data of your smartphone and register the appliance using the Wi-Fi network. |
| | The wireless network name (SSID) is set incorrectly. | The wireless network name (SSID) should be a combination of English letters and numbers. (Do not use special characters.) |
| | The router frequency is not 2.4 GHz. | Only a 2.4 GHz router frequency is supported. Set the wireless router to 2.4 GHz and connect the appliance to the wireless router. To check the router frequency, check with your Internet service provider or the router manufacturer. |
| | The distance between the appliance and the router is too far. | If the distance between the appliance and the router is too far, the signal may be weak and the connection may not be configured correctly. Move the location of the router so that it is closer to the appliance. |

NOTE

- If you see "CH" in the display, please call 1-888-865-3026(US), 1-855-286-2456(Canada).

WARRANTY (USA)

ARBITRATION NOTICE: THIS LIMITED WARRANTY CONTAINS AN ARBITRATION PROVISION THAT REQUIRES YOU AND LG TO RESOLVE DISPUTES BY BINDING ARBITRATION INSTEAD OF IN COURT, UNLESS YOU CHOOSE TO OPT OUT. IN ARBITRATION, CLASS ACTIONS AND JURY TRIALS ARE NOT PERMITTED. PLEASE SEE THE SECTION TITLED "PROCEDURE FOR RESOLVING DISPUTES" BELOW.

PROCEDURE FOR RESOLVING DISPUTES:

ALL DISPUTES BETWEEN YOU AND LG ARISING OUT OF OR RELATING IN ANY WAY TO THIS LIMITED WARRANTY OR THE PRODUCT SHALL BE RESOLVED EXCLUSIVELY THROUGH BINDING ARBITRATION, AND NOT IN A COURT OF GENERAL JURISDICTION. BINDING ARBITRATION MEANS THAT YOU AND LG ARE EACH WAIVING THE RIGHT TO A JURY TRIAL AND TO BRING OR PARTICIPATE IN A CLASS ACTION.

Definitions. For the purposes of this section, references to "LG" mean LG Electronics U.S.A., Inc., its parents, subsidiaries and affiliates, and each of their officers, directors, employees, agents, beneficiaries, predecessors in interest, successors, assigns and suppliers; references to "dispute" or "claim" shall include any dispute, claim or controversy of any kind whatsoever (whether based in contract, tort, statute, regulation, ordinance, fraud, misrepresentation or any other legal or equitable theory) arising out of or relating in any way to the sale, condition or performance of the product or this Limited Warranty.

Notice of Dispute. In the event you intend to commence an arbitration proceeding, you must first notify LG in writing at least 30 days in advance of initiating the arbitration by sending a letter to LG at LG Electronics, USA, Inc. Attn: Legal Department- amicably resolve your claim. The notice must provide your name, address, and telephone number; identify the product that is the subject of the claim; and describe the nature of the claim and the relief being sought. If you and LG are unable to resolve the dispute within 30 days, either party may proceed to file a claim for arbitration.

Agreement to Binding Arbitration and Class Action Waiver. Upon failure to resolve the dispute during the 30 day period after sending written notice to LG, you and LG agree to resolve any claims between us only by binding arbitration on an individual basis, unless you opt out as provided below. Any dispute between you and LG shall not be combined or consolidated with a dispute involving any other person's or entity's product or claim. More specifically, without limitation of the foregoing, any dispute between you and LG shall not under any circumstances proceed as part of a class or representative action. Instead of arbitration, either party may bring an individual action in small claims court, but that small claims court action may not be brought on a class or representative basis.

Arbitration Rules and Procedures. To begin arbitration of a claim, either you or LG must make a written demand for arbitration. The arbitration will be administered by the American Arbitration Association ("AAA") and will be conducted before a single arbitrator under the AAA's Consumer Arbitration Rules that are in effect at the time the arbitration is initiated (referred to as the "AAA Rules") and under the procedures set forth in this section. The AAA Rules are available online at www.adr.org/consumer. Send a copy of your written demand for arbitration, as well as a copy of this provision, to the AAA in the manner described in the AAA Rules. You must also send a copy of your written demand to LG at LG Electronics, USA, Inc. Attn: Legal Department- Arbitration 111 Sylvan Avenue Englewood Cliffs, NJ 07632. If there is a conflict between the AAA Rules and the rules set forth in this section, the rules set forth in this section will govern. This arbitration provision is governed by the Federal Arbitration Act. Judgment may be entered on the arbitrator's award in any court of competent jurisdiction. All issues are for the arbitrator to decide, except that issues relating to the scope and enforceability of the arbitration provision and to the arbitrability of the dispute are for the court to decide. The arbitrator is bound by the terms of this provision.

Governing Law. The law of the state of your residence shall govern this Limited Warranty and any disputes between us except to the extent that such law is preempted by or inconsistent with applicable federal law.

Fees/Costs. You do not need to pay any fee to begin an arbitration. Upon receipt of your written demand for arbitration, LG will promptly pay all arbitration filing fees to the AAA unless you seek more than \$25,000 in damages, in which case the payment of these fees will be governed by the AAA Rules. Except as otherwise provided for herein, LG will pay all AAA filing, administration and arbitrator fees for any arbitration initiated in accordance with the AAA Rules and this arbitration provision. If you prevail in the arbitration, LG will pay your attorneys' fees and expenses as long as they are reasonable, by considering factors including, but not limited to, the purchase amount and claim amount. Notwithstanding the foregoing, if applicable law allows for an award of reasonable attorneys' fees and expenses, an arbitrator can award them to the same extent that a court would. If the arbitrator finds either the substance of your claim or the relief sought in the demand is frivolous or brought for an improper purpose (as measured by the standards set forth in Federal Rule of Civil Procedure 11(b)), then the payment of all arbitration fees will be governed by the AAA Rules. In such a situation, you agree to reimburse LG for all monies previously disbursed by it that are otherwise your obligation to pay under the AAA Rules. Except as otherwise provided for, LG waives any rights it may have to seek attorneys' fees and expenses from you if LG prevails in the arbitration.

Hearings and Location. If your claim is for \$25,000 or less, you may choose to have the arbitration conducted solely on the basis of (1) documents submitted to the arbitrator, (2) through a telephonic hearing, or (3) by an in-person hearing as established by the AAA Rules. If your claim exceeds \$25,000, the right to a hearing will be determined by the AAA Rules. Any in-person arbitration hearings will be held at a location within the federal judicial district in which you reside unless we both agree to another location or we agree to a telephonic arbitration.

Opt Out. You may opt out of this dispute resolution procedure. If you opt out, neither you nor LG can require the other to participate in an arbitration proceeding. To opt out, you must send notice to LG no later than 30 calendar days from the date of the first consumer purchaser's purchase of the product by either: (i) sending an e-mail to optout@lge.com, with the subject line: "Arbitration Opt Out" or (ii) calling 1-800-980-2973. You must include in the opt out e-mail or provide by telephone: (a) your name and address; (b) the date on which the product was purchased; (c) the product model name or model number; and (d) the first consumer purchaser's purchase of the product by either: (i) sending an e-mail to optout@lge.com, with the subject line: the serial number (the serial number can be found (i) on the product; or (ii) online by accessing <https://www.lg.com/us/support/repair-service/schedule-repair-continued> and clicking on "Find My Model & Serial Number").

You may only opt out of the dispute resolution procedure in the manner described above (that is, by e-mail or telephone); no other form of notice will be effective to opt out of this dispute resolution procedure. Opting out of this dispute resolution procedure will not affect the coverage of the Limited Warranty in any way, and you will continue to enjoy the full benefits of the Limited Warranty. If you keep this product and do not opt out, then you accept all terms and conditions of the arbitration provision described above.

WARRANTY (CANADA)

ARBITRATION NOTICE: THIS LIMITED WARRANTY CONTAINS AN ARBITRATION PROVISION THAT REQUIRES YOU AND LG TO RESOLVE DISPUTES BY BINDING ARBITRATION INSTEAD OF IN COURT, UNLESS THE LAWS OF YOUR PROVINCE OR TERRITORY DO NOT PERMIT THAT, OR, IN OTHER JURISDICTIONS, IF YOU CHOOSE TO OPT OUT. IN ARBITRATION, CLASS ACTIONS AND JURY TRIALS ARE NOT PERMITTED. PLEASE SEE THE SECTION TITLED "PROCEDURE FOR RESOLVING DISPUTES" BELOW.

PROCEDURE FOR RESOLVING DISPUTES:

EXCEPT WHERE PROHIBITED AT LAW, ALL DISPUTES BETWEEN YOU AND LG ARISING OUT OF OR RELATING IN ANY WAY TO THIS LIMITED WARRANTY OR THE PRODUCT SHALL BE RESOLVED EXCLUSIVELY THROUGH BINDING ARBITRATION, AND NOT IN A COURT OF GENERAL JURISDICTION. EXCEPT WHERE PROHIBITED AT LAW, YOU AND LG BOTH IRREVOCABLY AGREE TO WAIVE THE RIGHT TO A JURY TRIAL AND TO BRING OR PARTICIPATE IN A CLASS ACTION.

Definitions. For the purposes of this section, references to "LG" mean LG Electronics Canada, Inc., its parents, subsidiaries and affiliates, and each of their officers, directors, employees, agents, beneficiaries, predecessors in interest, successors, assigns and suppliers; references to "dispute" or "claim" shall include any dispute, claim or controversy of any kind whatsoever (whether based in contract, tort, statute, regulation, ordinance, fraud, misrepresentation or any other legal or equitable theory) arising out of or relating in any way to the sale, condition or performance of the product or this Limited Warranty.

Notice of Dispute. In the event you intend to commence an arbitration proceeding, you must first notify LG in writing at least 30 days in advance of initiating the arbitration by sending a letter to LGECI Legal Team at 20 Norelco Drive, North York, Ontario, Canada M9L 2X6 (the "Notice of Dispute"). You and LG agree to engage in good faith discussions in an attempt to amicably resolve your claim. The notice must provide your name, address, and telephone number; identify the product that is the subject of the claim; and describe the nature of the claim and the relief being sought. If you and LG are unable to resolve the dispute within 30 days of LG's receipt of the Notice of Dispute, the dispute shall be resolved by binding arbitration in accordance with the procedure set out herein. You and LG both agree that, during the arbitration proceeding, the terms (including any amount) of any settlement offer made by either you or LG will not be disclosed to the arbitrator until the arbitrator determines the dispute.

Agreement to Binding Arbitration and Class Action Waiver. Upon failure to resolve the dispute during the 30 day period after LG's receipt of the Notice of Dispute, you and LG agree to resolve any claims between you and LG only by binding arbitration on an individual basis, unless you opt out as provided below, or you reside in a jurisdiction that prevents full application of this clause in the circumstances of the claims at issue (in which case if you are a consumer, this clause will only apply if you expressly agree to the arbitration). To the extent permitted by applicable law, any dispute between you and LG shall not be combined or consolidated with a dispute involving any other person's or entity's product or claim. More specifically, without limitation of the foregoing, except to the extent such a prohibition is not permitted at law, any dispute between you and LG shall not under any circumstances proceed as part of a class or representative action. Instead of arbitration, either party may bring an individual action in small claims court, but that small claims court action may not be brought on a class or representative basis except to the extent this prohibition is not permitted at law in your province or territory of jurisdiction as it relates to the claims at issue between you and LG.

Arbitration Rules and Procedures. To begin arbitration of a claim, either you or LG must make a written demand for arbitration. The arbitration will be private and confidential, and conducted on a simplified and expedited basis before a single arbitrator chosen by the parties under the provincial or territorial commercial arbitration law and rules of the province or territory of your residence. You must also send a copy of your written demand to LG at LG Electronics, Canada, Inc., Attn: Legal Department- Arbitration, 20 Norelco Drive, North York, Ontario M9L 2X6. This arbitration provision is governed by your applicable provincial or territorial commercial arbitration legislation. Judgment may be entered on the arbitrator's award in any court of competent jurisdiction. All issues are for the arbitrator to decide, except that, issues relating to the scope and enforceability of the arbitration provision and to the arbitrability of the dispute are for the court to decide. The arbitrator is bound by the terms of this provision.

Governing Law. The law of the province or territory of your purchase shall govern this Limited Warranty and any disputes between you and LG except to the extent that such law is preempted by or inconsistent with applicable federal or provincial/territorial law. Should arbitration not be permitted for any claim, action, dispute or controversy between you and LG, you and LG attach to the exclusive jurisdiction of the courts of the province or territory of your purchase for the resolution of the claim, action, dispute or controversy between you and LG.

Fees/Costs. You do not need to pay any fee to begin an arbitration. Upon receipt of your written demand for arbitration, LG will promptly pay all arbitration filing fees unless you seek more than \$25,000 in damages, in which case the payment of these fees will be governed by the applicable arbitration rules. Except as otherwise provided for herein, LG will pay all filing, administration and arbitrator fees for any arbitration initiated in accordance with the applicable arbitration rules and this arbitration provision. If you prevail in the arbitration, LG will pay your attorneys' fees and expenses as long as they are reasonable, by considering factors including, but not limited to, the purchase amount and claim amount. Notwithstanding the foregoing, if applicable law allows for an award of reasonable attorneys' fees and expenses, an arbitrator can award them to the same extent that a court would. If the arbitrator finds either the substance of your claim or the relief sought in the demand is frivolous or brought for an improper purpose (as measured by the applicable laws), then the payment of all arbitration fees will be governed by the applicable arbitration rules. In such a situation, you agree to reimburse LG for all monies previously disbursed by it that are otherwise your obligation to pay under the applicable arbitration rules. Except as otherwise provided for, LG waives any rights it may have to seek attorneys' fees and expenses from you if LG prevails in the arbitration.

Hearings and Location. If your claim is for \$25,000 or less, you may choose to have the arbitration conducted solely (1) on the basis of documents submitted to the arbitrator, (2) through a telephonic hearing, or (3) by an in-person hearing as established by the applicable arbitration rules. If your claim exceeds \$25,000, the right to a hearing will be determined by the applicable arbitration rules. Any in-person arbitration hearings will be held at the nearest, most mutually-convenient arbitration location available within the province or territory in which you reside unless you and LG both agree to another location or agree to a telephonic arbitration.

Severability and Waiver. If any portion of this Limited Warranty (including these arbitration procedures) is unenforceable, the remaining provisions will continue in full force and effect to the maximum extent permitted by applicable law. Should LG fail to enforce strict performance of any provision of this Limited Warranty (including these arbitration procedures), it does not mean that LG intends to waive or has waived any provision or part of this Limited Warranty.

Opt Out. You may opt out of this dispute resolution procedure. If you opt out, neither you nor LG can require the other to participate in an arbitration proceeding. To opt out, you must send notice to LG no later than 30 calendar days from the date of the first consumer purchaser's purchase of the product by either (i) sending an e-mail to optout@lge.com, with the subject line: "Arbitration Opt Out;" or (ii) calling 1-800-980-2973. You must include in the opt out e-mail or provide by telephone: (a) your name and address; (b) the date on which the product was purchased; (c) the product model name or model number; and (d) the serial number (the serial number can be found (i) on the product; or (ii) online by accessing https://www.lg.com/ca_en/support/repair-service/schedule-repair and clicking on "Find My Model & Serial Number").

In the event that you "Opt Out", the law of the province or territory of your residence shall govern this Limited Warranty and any disputes between you and LG except to the extent that such law is preempted by or inconsistent with applicable federal or provincial/territorial law. Should arbitration not be permitted for any claim, action, dispute or controversy between you and LG, you and LG agree to attorn to the exclusive jurisdiction of the courts of the province or territory of your residence for the resolution of the claim, action, dispute or controversy between you and LG.

You may only opt out of the dispute resolution procedure in the manner described above (that is, by e-mail or telephone); no other form of notice will be effective to opt out of this dispute resolution procedure. Opting out of this dispute resolution procedure will not affect the coverage of the Limited Warranty in any way, and you will continue to enjoy the full benefits of the Limited Warranty. If you keep this product and do not opt out, then you accept all terms and conditions of the arbitration provision described above.

Conflict of Terms. In the event of a conflict or inconsistency between the terms of this Limited Warranty and the End User License Agreement ("EULA") in regards to dispute resolution, the terms of this Limited Warranty shall control and govern the rights and obligations of the parties and shall take precedence over the EULA.

