



ENGLISH

ESPAÑOL

PORTUGUÊS

INSTALLATION MANUAL

AIR CONDITIONER

Please read this installation manual completely before installing the product. Installation work must be performed in accordance with the national wiring standards by authorized personnel only. Please retain this installation manual for future reference after reading it thoroughly.

MULTI V 5

For Heat Pump / Heat Recovery system
Original instruction



MFL67221444
Rev.00_091818

www.lg.com

Copyright © 2017 - 2018 LG Electronics Inc. All Rights Reserved.

TIPS FOR SAVING ENERGY

Here are some tips that will help you minimize the power consumption when you use the air conditioner. You can use your air conditioner more efficiently by referring to the instructions below:

- Do not cool excessively indoors. This may be harmful for your health and may consume more electricity.
- Block sunlight with blinds or curtains while you are operating the air conditioner.
- Keep doors or windows closed tightly while you are operating the air conditioner.
- Adjust the direction of the air flow vertically or horizontally to circulate indoor air.
- Speed up the fan to cool or warm indoor air quickly, in a short period of time.
- Open windows regularly for ventilation as the indoor air quality may deteriorate if the air conditioner is used for many hours.
- Clean the air filter once every 2 weeks. Dust and impurities collected in the air filter may block the air flow or weaken the cooling / dehumidifying functions.

For your records

Staple your receipt to this page in case you need it to prove the date of purchase or for warranty purposes. Write the model number and the serial number here:

Model number : _____

Serial number : _____

You can find them on a label on the side of each unit.

Dealer's name : _____

Date of purchase : _____

IMPORTANT SAFETY INSTRUCTIONS

READ ALL INSTRUCTIONS BEFORE USING THE APPLIANCE.

Always comply with the following precautions to avoid dangerous situations and ensure peak performance of your product

! WARNING

It can result in serious injury or death when the directions are ignored

! CAUTION

It can result in minor injury or product damage when the directions are ignored

! WARNING

- Installation or repairs made by unqualified persons can result in hazards to you and others.
- The information contained in the manual is intended for use by a qualified service technician familiar with safety procedures and equipped with the proper tools and test instruments.
- Failure to carefully read and follow all instructions in this manual can result in equipment malfunction, property damage, personal injury and/or death.

Installation

- Have all electric work done by a licensed electrician according to "Electric Facility Engineering Standard" and "Interior Wire Regulations" and the instructions given in this manual and always use a special circuit.
 - If the power source capacity is inadequate or electric work is performed improperly, electric shock or fire may result.
- Ask the dealer or an authorized technician to install the air conditioner.
 - Improper installation by the user may result in water leakage, electric shock, or fire.
- Always ground the product.
 - There is risk of fire or electric shock.
- Always install a dedicated circuit and breaker.
 - Improper wiring or installation may cause fire or electric shock.
- For re-installation of the installed product, always contact a dealer or an Authorized Service Center.
 - There is risk of fire, electric shock, explosion, or injury.
- Do not install, remove, or re-install the unit by yourself (customer).
 - There is risk of fire, electric shock, explosion, or injury.
- Do not store or use flammable gas or combustibles near the air conditioner.
 - There is risk of fire or failure of product.
- Use the correctly rated breaker or fuse.
 - There is risk of fire or electric shock.
- Prepare for strong wind or earthquake and install the unit at the specified place.
 - Improper installation may cause the unit to topple and result in injury.
- Do not install the product on a defective installation stand.
 - It may cause injury, accident, or damage to the product.
- Use a vacuum pump or Inert(nitrogen) gas when doing leakage test or air purge. Do not compress air or Oxygen and do not use Flammable gases. Otherwise, it may cause fire or explosion.
 - There is the risk of death, injury, fire or explosion.
- When installing and moving the air conditioner to another site, do not charge it with a different refrigerant from the refrigerant specified on the unit.
 - If a different refrigerant or air is mixed with the original refrigerant, the refrigerant cycle may malfunction and the unit may be damaged.
- Do not reconstruct to change the settings of the protection devices.
 - If the pressure switch, thermal switch, or other protection device is shorted and operated forcibly, or parts other than those specified by LGE are used, fire or explosion may result.
- Ventilate before operating air conditioner when gas leaked out.
 - It may cause explosion, fire, and burn.
- Securely install the cover of control box and the panel.
 - If the cover and panel are not installed securely, dust or water may enter the outdoor unit and fire or electric shock may result.

- If the air conditioner is installed in a small room, measures must be taken to prevent the refrigerant concentration from exceeding the safety limit when the refrigerant leaks.
 - Consult the dealer regarding the appropriate measures to prevent the safety limit from being exceeded. Should the refrigerant leak and cause the safety limit to be exceeded, hazards due to lack of oxygen in the room could result.

Operation

- Do not damage or use an unspecified power cord.
 - There is risk of fire, electric shock, explosion, or injury.
- Use a dedicated outlet for this appliance.
 - There is risk of fire or electrical shock.
- Be cautious that water could not enter the product.
 - There is risk of fire, electric shock, or product damage.
- Do not touch the power switch with wet hands.
 - There is risk of fire, electric shock, explosion, or injury.
- When the product is soaked (flooded or submerged), contact an Authorized Service Center.
 - There is risk of fire or electric shock.
- Be cautious not to touch the sharp edges when installing.
 - It may cause injury.
- Take care to ensure that nobody could step on or fall onto the outdoor unit.
 - This could result in personal injury and product damage.
- Do not open the inlet grille of the product during operation. (Do not touch the electrostatic filter, if the unit is so equipped.)
 - There is risk of physical injury, electric shock, or product failure.

CAUTION

Installation

- Always check for gas (refrigerant) leakage after installation or repair of product.
 - Low refrigerant levels may cause failure of product.
- Do not install the product where the noise or hot air from the outdoor unit could damage the neighborhoods.
 - It may cause a problem for your neighbors.
- Keep level even when installing the product.
 - To avoid vibration or water leakage.
- Do not install the unit where combustible gas may leak.
 - If the gas leaks and accumulates around the unit, an explosion may result.
- Use power cables of sufficient current carrying capacity and rating.
 - Cables that are too small may leak, generate heat, and cause a fire.
- Do not use the product for special purposes, such as preserving foods, works of art, etc. It is a consumer air conditioner, not a precision refrigeration system.
 - There is risk of damage or loss of property.
- Keep the unit away from children. The heat exchanger is very sharp.
 - It can cause the injury, such as cutting the finger. Also the damaged fin may result in degradation of capacity.
- When installing the unit in a hospital, communication station, or similar place, provide sufficient protection against noise.
 - The inverter equipment, private power generator, high-frequency medical equipment, or radio communication equipment may cause the air conditioner to operate erroneously, or fail to operate. On the other hand, the air conditioner may affect such equipment by creating noise that disturbs medical treatment or image broadcasting.
- Do not install the product where it is exposed to sea wind (salt spray) directly.
 - It may cause corrosion on the product. Corrosion, particularly on the condenser and evaporator fins, could cause product malfunction or inefficient operation.

Operation

- Do not use the air conditioner in special environments.
 - Oil, steam, sulfuric smoke, etc. can significantly reduce the performance of the air conditioner or damage its parts.
- Do not block the inlet or outlet.
 - It may cause failure of appliance or accident.
- Make the connections securely so that the outside force of the cable may not be applied to the terminals.
 - Inadequate connection and fastening may generate heat and cause a fire.
- Be sure the installation area does not deteriorate with age.
 - If the base collapses, the air conditioner could fall with it, causing property damage, product failure, or personal injury.

- Install and insulate the drain hose to ensure that water is drained away properly based on the installation manual.
 - A bad connection may cause water leakage.
- Be very careful about product transportation.
 - Only one person should not carry the product if it weighs more than 20 kg.
 - Some products use PP bands for packaging. Do not use any PP bands for a means of transportation. It is dangerous.
 - Do not touch the heat exchanger fins. Doing so may cut your fingers.
 - When transporting the outdoor unit, suspending it at the specified positions on the unit base. Also support the outdoor unit at four points so that it cannot slip sideways.
- Safely dispose of the packing materials.
 - Packing materials, such as nails and other metal or wooden parts, may cause stabs or other injuries.
 - Tear apart and throw away plastic packaging bags so that children may not play with them. If children play with a plastic bag which was not torn apart, they face the risk of suffocation.
- Turn on the power at least 6 hours before starting operation.
 - Starting operation immediately after turning on the main power switch can result in severe damage to internal parts. Keep the power switch turned on during the operational season.
- Do not touch any of the refrigerant piping during and after operation.
 - It can cause a burn or frostbite.
- Do not operate the air conditioner with the panels or guards removed.
 - Rotating, hot, or high-voltage parts can cause injuries.
- Do not directly turn off the main power switch after stopping operation.
 - Wait at least 5 minutes before turning off the main power switch. Otherwise it may result in water leakage or other problems.
- Auto-addressing should be done in condition of connecting the power of all indoor and outdoor units. Auto-addressing should also be done in case of changing the indoor unit PCB.
- Use a firm stool or ladder when cleaning or maintaining the air conditioner.
 - Be careful and avoid personal injury.
- Do not insert hands or other objects through the air inlet or outlet while the air conditioner is plugged in.
 - There are sharp and moving parts that could cause personal injury.

TABLE OF CONTENTS

2 TIPS FOR SAVING ENERGY

2 IMPORTANT SAFETY INSTRUCTIONS

5 INSTALLATION PROCESS

5 OUTDOOR UNITS INFORMATION

5 ALTERNATIVE REFRIGERANT R410A

5 SELECT THE BEST LOCATION

7 INSTALLATION SPACE

7 Individual Installation

7 LIFTING METHOD

8 INSTALLATION

8 The location of the Anchor bolts

8 Foundation for Installation

9 Preparation of Piping

10 Plumbing materials and storage methods

11 REFRIGERANT PIPING INSTALLATION

11 Precautions on Pipe connection / Valve operation

11 Connection of Outdoor units

12 Caution

13 Precautions on Pipe connection / Valve operation

13 Connection of Outdoor units

13 Installation procedure for HR unit

14 Installation of Outdoor Unit, HR Unit, Indoor Unit Refrigerant Pipe

14 Type of HR Unit

14 Installation of Zoning Control

15 Caution

16 PIPE CONNECTIONS BETWEEN INDOOR AND OUTDOOR UNIT

16 Preparation Work

16 Pipe Drawing Out during Single / Series connection

17 Refrigerant piping system

18 Preparation Work

18 Pipe Drawing Out during Single / Series connection

19 Refrigerant piping system

21 Pipe Connection Method between outdoor unit/indoor unit

24 Branch pipe Fitting

26 Distribution Method

26 Vacuum Mode

27 Leak Test and Vacuum drying

28 Refrigerant charging

29 Thermal insulation of refrigerant piping

30 ELECTRICAL WIRING

30 Caution

32 Control box and connecting position of wiring

32 Communication and Power Cables

33 Wiring of main power supply and equipment capacity

33 Field Wiring

35 Checking the setting of outdoor units

36 Switch for setup of HR Unit

38 Automatic Addressing

38 The Procedure of Automatic Addressing

39 Flow chart of auto pipe detection process

40 Flow chart of manual addressing for pipe detection

40 Example of manual valve addressing (Non-Zoning setting)

40 Example of manual valve addressing (Zoning setting)

41 Example of checking valve address

41 Identification of Manual Valve ID (Address)

41 Method of checking the pipe detection result at outdoor unit

41 Setting method of Master indoor unit in zoning

41 Group Number setting

42 Cool & Heat selector

43 High Static Pressure Compensation mode

43 Night Low Noise Function

43 Overall defrost mode

43 Setting the ODU address

44 Snow removal & rapid defrost

44 Setting Capacity Up Airflow Adjusting for IDU (Heating)

44 Target pressure adjusting

44 Low Ambient Kit

45 High Efficiency Mode (Cooling Operation)

45 Auto Dust Removal Mode

45 Compressor Max. Frequency Limit

45 ODU Fan Max. RPM Limit

46 SLC (Smart Load Control)

46 Humidity Reference

46 Central Control Connection at Indoor Unit side

46 Compressor Input Current Limit

47 Power Consumption Display on wired remote controller

47 Overall Defrost Operating in Low temperature (Heating)

47 Base pan Heater operation

47 Comfort Cooling operation

48 Self-Diagnosis Function

51 CAUTION FOR REFRIGERANT LEAK

51 Introduction

51 Checking procedure of limiting concentration

52 INSTALLATION GUIDE AT THE SEASIDE

52 Model Designation

52 Airborne Noise Emission

INSTALLATION PROCESS

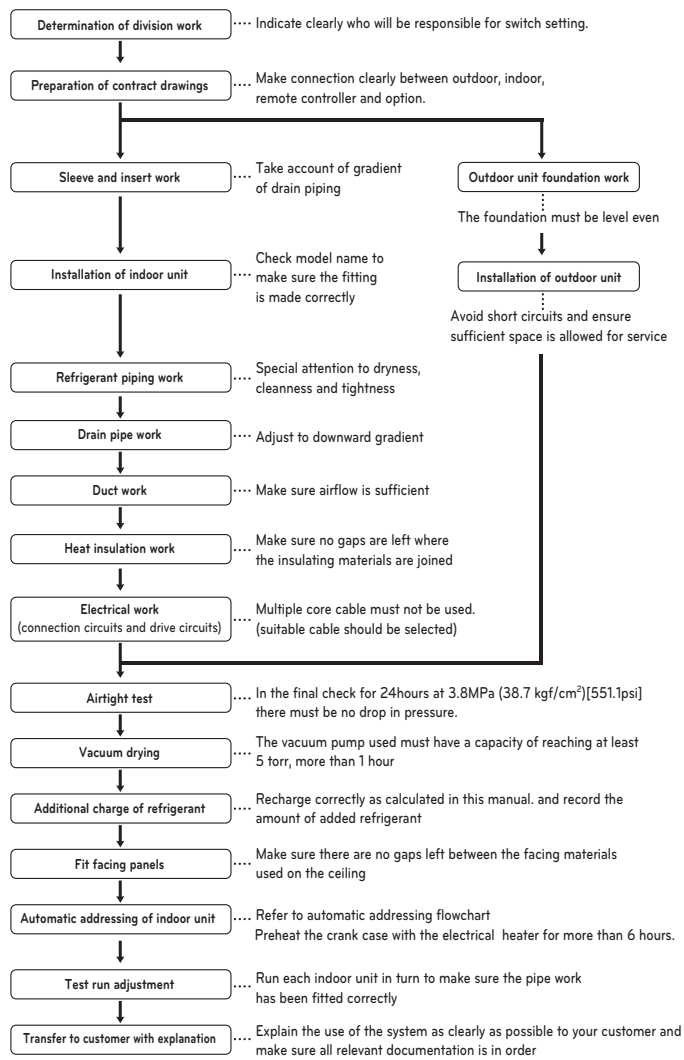

CAUTION

- The above list indicates the order in which the individual work operations are normally carried out but this order may be varied where local conditions warrants such change.
- The thickness of the piping should comply with the relevant local and national regulations for the designed pressure 3.8 MPa (551.1 psi).
- Since R410A is a mixed refrigerant, the required additional refrigerant must be charged in its liquid state. (If the refrigerant is charged in its gaseous state, its composition changes and the system will not work properly.)

OUTDOOR UNITS INFORMATION

CAUTION

Combination Ratio(50~200%)

Outdoor Number	Connection Ratio
Single outdoor units	200%
Double outdoor units	160%
Triple outdoor units	130%
Over the triple unit	130%

Notes : * We can guarantee the operation only within 130% combination. If you want to connect more than 130% combination, please contact us and discuss the requirement like below.

- If the operation of indoor unit is more than 130%, the airflow will be operated as low in the all indoor units.

ALTERNATIVE REFRIGERANT R410A

The refrigerant R410A has the property of higher operating pressure in comparison with R22.

Therefore, all materials have the characteristics of higher resisting pressure than R22 ones and this characteristic should also be considered during the installation.

R410A is an azeotrope of R32 and R125 mixed at 50:50, so the ozone depletion potential (ODP) of R410A is 0.

CAUTION

- The wall thickness of the piping should comply with the relevant local and national regulations for the designed pressure 3.8MPa [551.1psi]
- Since R410A is a mixed refrigerant, the required additional refrigerant must be charged in its liquid state. If the refrigerant is charged in its gaseous state, its composition changes and the system will not work properly.
- Do not place the refrigerant container under the direct rays of the sun to prevent it from exploding.
- For high-pressure refrigerant, any unapproved pipe must not be used.
- Do not heat pipes more than necessary to prevent them from softening.
- Be careful not to install wrongly to minimize economic loss because it is expensive in comparison with R22.

SELECT THE BEST LOCATION

Select space for installing outdoor unit, which will meet the following conditions:

- No direct thermal radiation from other heat sources
- No possibility of annoying neighbors due to noise of unit
- No exposition to strong wind
- With strength which bears weight of unit
- Note that drain flows out of unit when heating
- Because of the possibility of fire, do not install unit to the space where generation, inflow, stagnation, and leakage of combustible gas is expected.

- Avoid unit installation in a place where acidic solution and spray (sulfur) are often used.
- Do not use unit under any special environment where oil, steam and sulfuric gas exist.
- It is recommended to fence round the outdoor unit in order to prevent any person or animal from accessing the outdoor unit.
- If installation site is area of heavy snowfall, then the following directions should be observed.
 - Make the foundation as high as possible.
 - Fit a snow protection hood.
- Select installation location considering following conditions to avoid bad condition when additionally performing defrost operation.
 - Install the outdoor unit at a place well ventilated and having a lot of sunshine in case of installing the product at a place With a high humidity in winter (near beach, coast, lake, etc.) (Ex : Rooftop where there is always sunshine.)

For Heat Recovery Installation

Select installation location of the HR unit suitable for following conditions

- Avoid a place where rain may enter since the HR unit is for indoor.
- Sufficient service space must be obtained.
- Refrigerant pipe must not exceed limited length.
- Avoid a place subject to a strong radiation heat from other heat source.
- Avoid a place where oil spattering, vapor spray or high frequency electric noise is expected.
- Install the unit at a place in which it is not affected by operation noise. (Installation within cell such as meeting room etc. may disturb business due to noise.)
- Place where refrigerant piping, drain piping and electrical wiring works are easy.

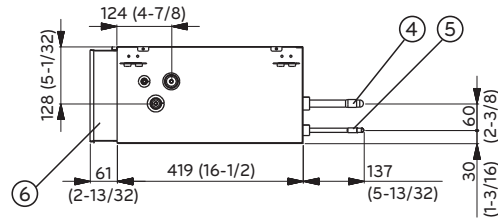
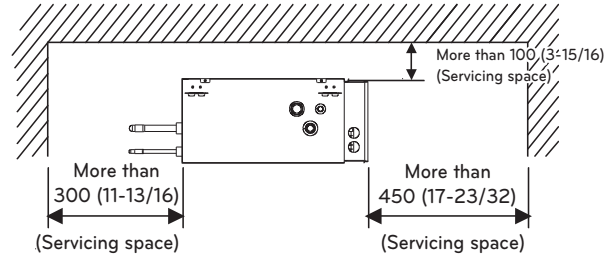
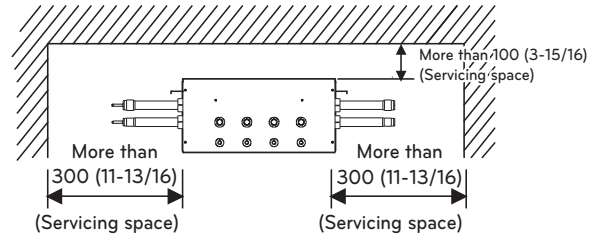

[Unit: mm(inch)]

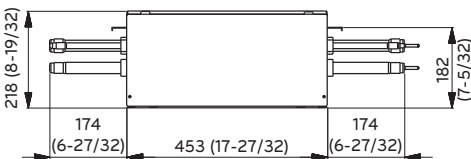
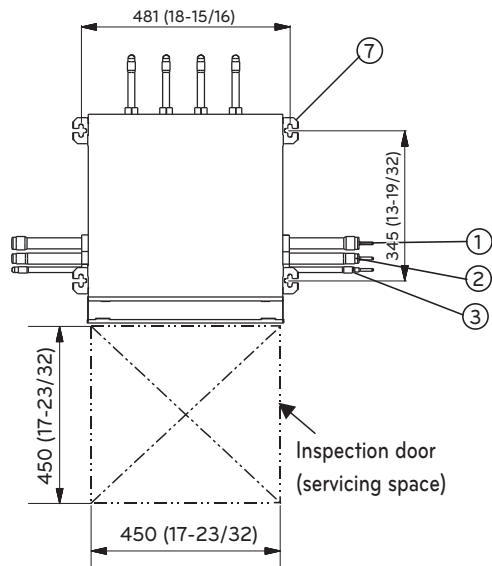

No.	Part Name	Description	
		PRHR042, PRHR042A PRHR032, PRHR032A	PRHR022, PRHR022A
1	Low pressure Gas pipe connection port	Ø28.58 (1-1/8) Brazing connection	Ø22.2 (7/8) Brazing connection
2	High pressure Gas pipe connection port	Ø22.2 (7/8) Brazing connection	Ø19.05 (3/4) Brazing connection
3	Liquid pipe connection port	Ø15.88 (5/8) Brazing connection (PRHR042, PRHR042A)	Ø9.52 (3/8) Brazing connection
		Ø12.7 (1/2) Brazing connection (PRHR032, PRHR032A)	
4	Indoor unit Gas pipe connection port	Ø15.88 (5/8) Brazing connection	Ø15.88 (5/8) Brazing connection
5	Indoor unit Liquid pipe connection port	Ø9.52 (3/8) Brazing connection	Ø9.52 (3/8) Brazing connection
6	Control box	-	-
7	Hanger metal	M10 or M8	M10 or M8

NOTE

- Be sure to install the inspection door at the control box side.
- If reducers are used, servicing space must be increased equal to reducer's dimension.

INSTALLATION SPACE

Individual Installation

During the installation of the unit, consider service, inlet, and outlet acquire the minimum space as shown in the figures below. Side space should be more than 49 mm for operating of Auto Dust Removal mode. [Unit : mm (inch)]

Category	Installation Space	Case 1 (10(13/32) ≤ Side Space ≤ 49(13/14))	Case 2 (Side Space ≥ 49(13/14))
4 sides are walls		A ≥ 10 (13/32) B ≥ 300 (11-13/16) C ≥ 10 (13/32) D ≥ 500 (19-11/16)	A ≥ 50 (1-31/32) B ≥ 100 (3-15/16) C ≥ 50 (1-31/32) D ≥ 500 (19-11/16)
		A ≥ 10 (13/32) B ≥ 300 (11-13/16) C ≥ 10 (13/32) D ≥ 500 (19-11/16) E ≥ 20 (25/32)	A ≥ 50 (1-31/32) B ≥ 100 (3-15/16) C ≥ 50 (1-31/32) D ≥ 500 (19-11/16) E ≥ 100 (3-15/16)
		A ≥ 10 (13/32) B ≥ 300 (11-13/16) C ≥ 10 (13/32) D ≥ 500 (19-11/16) E ≥ 20 (25/32) F ≥ 600 (23-5/8)	A ≥ 50 (1-31/32) B ≥ 100 (3-15/16) C ≥ 50 (1-31/32) D ≥ 500 (19-11/16) E ≥ 100 (3-15/16) F ≥ 500 (19-11/16)
		A ≥ 10 (13/32) B ≥ 300 (11-13/16) C ≥ 10 (13/32) D ≥ 300 (11-13/16) E ≥ 20 (25/32) F ≥ 500 (19-11/16)	A ≥ 50 (1-31/32) B ≥ 100 (3-15/16) C ≥ 50 (1-31/32) D ≥ 100 (3-15/16) E ≥ 100 (3-15/16) F ≥ 500 (19-11/16)
Rear to Rear		A ≥ 10 (13/32) B ≥ 500 (19-11/16) C ≥ 10 (13/32) D ≥ 500 (19-11/16) F ≥ 900 (35-7/16)	A ≥ 50 (1-31/32) B ≥ 500 (19-11/16) C ≥ 50 (1-31/32) D ≥ 500 (19-11/16) F ≥ 600 (23-5/8)
		A ≥ 10 (13/32) B ≥ 500 (19-11/16) C ≥ 10 (13/32) D ≥ 500 (19-11/16) E ≥ 20 (25/32) F ≥ 1200 (47-1/4)	A ≥ 50 (1-31/32) B ≥ 500 (19-11/16) C ≥ 50 (1-31/32) D ≥ 500 (19-11/16) E ≥ 100 (3-15/16) F ≥ 900 (35-7/16)
		A ≥ 10 (13/32) B ≥ 500 (19-11/16) C ≥ 10 (13/32) D ≥ 500 (19-11/16) E ≥ 20 (25/32) F ≥ 1800 (70-7/8)	A ≥ 50 (1-31/32) B ≥ 500 (19-11/16) C ≥ 50 (1-31/32) D ≥ 500 (19-11/16) E ≥ 100 (3-15/16) F ≥ 1200 (47-1/4)
Only 2 sides are walls		A ≥ 10 (13/32) B ≥ 300 (11-13/16)	No limit for the height of wall
		A ≥ 10 (13/32) B ≥ 300 (11-13/16) E ≥ 20 (25/32)	No limit for the height of wall
Limitations on the height of the wall (Refer to 4 side walls)	<ul style="list-style-type: none"> The height of the wall on the front side must be 1500 mm (59 inch) or less. The height of the wall on the inlet side must be 500 mm (19-11/16 inch) or less. There is no limit to the wall on Inlet side. If the height of the walls on the front and Inlet side are higher than the limit, there must be additional space on the front and the side. <ul style="list-style-type: none"> - Additional Space on the front side by 1/2 of h1 - Additional Space on the inlet side by 1/2 of h2 - h1 = A(Actual height) - 1500 mm (59 inch) - h2 = B(Actual height) - 500 mm (19-11/16 inch) 		

Seasonal wind and cautions in winter

- Sufficient measures are required in a snow areas or severe cold areas in winter so that product can be operated well.
- Get ready for seasonal wind or snow in winter even in other areas.
- Install a suction and discharge duct not to let in snow or rain.
- Install the outdoor unit In such a way that it should not come in contact with snow directly. If snow piles up and freezes on the air suction hole, the system may malfunction. If it is installed at snowy area, attach the hood to the system.
- Install the outdoor unit at the higher installation console by 50 cm (19.7 inch) than the average snowfall (annual average snowfall) if it is installed at the area with much snowfall.
- Where snow accumulated on the upper part of the Outdoor Unit by more than 10 cm (3.9 inch), always remove snow for operation.

- The height of H frame must be more than 2 times the snowfall and its width shall not exceed the width of the product. (If width of the frame is wider than that of the product, snow may accumulate)

- Don't install the suction hole and discharge hole of the Outdoor Unit facing the seasonal wind.

Remove the Rear Grille

- Remove the rear grille in snowy area.
- Make sure that heat exchanger should not be damaged.

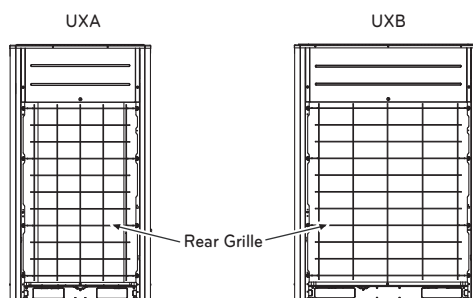

LIFTING METHOD

- When carrying the suspended, unit pass the ropes under the unit and use the two suspension points each at the front and rear.
- Always lift the unit with ropes attached at four points so that impact is not applied to the unit.
- Attach the ropes to the unit at an angle of 40° or less.

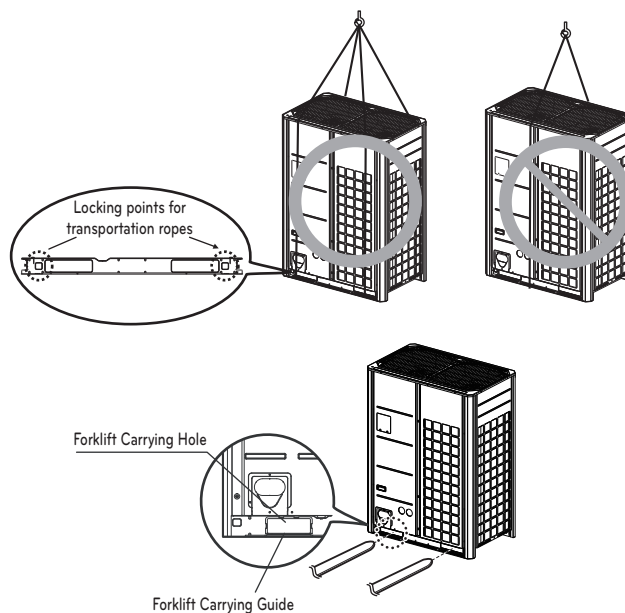

CAUTION

Be very careful while carrying the product.

- Do not have only one person carry product if it is more than 20 kg (44lbs).
- PP bands are used to pack some products. Do not use them as a mean for transportation because they are dangerous.
- Do not touch heat exchanger fins with your bare hands. Otherwise you may get a cut in your hands.
- Tear plastic packaging bag and scrap it so that children cannot play with it. Otherwise plastic packaging bag may suffocate children to death.
- When carrying in Outdoor Unit, be sure to support it at four points. Carrying in and lifting with 3-point support may make Outdoor Unit unstable, resulting in a fall.
- Use 2 belts of at least 8 m (26.2 ft) long.
- Place extra cloth or boards in the locations where the casing comes in contact with the sling to prevent damage.
- Hoist the unit making sure it is being lifted at its center of gravity.

INSTALLATION

- Install at places where it can endure the weight and vibration/noise of the outdoor unit.
- The outdoor unit support blocks at the bottom shall have width of at least 100 mm (3-15/16 inch) under the Unit's legs before being fixed.
- The outdoor unit support blocks should have minimum height of 200 mm (7-7/8 inch).
- Anchor bolts must be inserted at least 75 mm (2-15/16 inch).

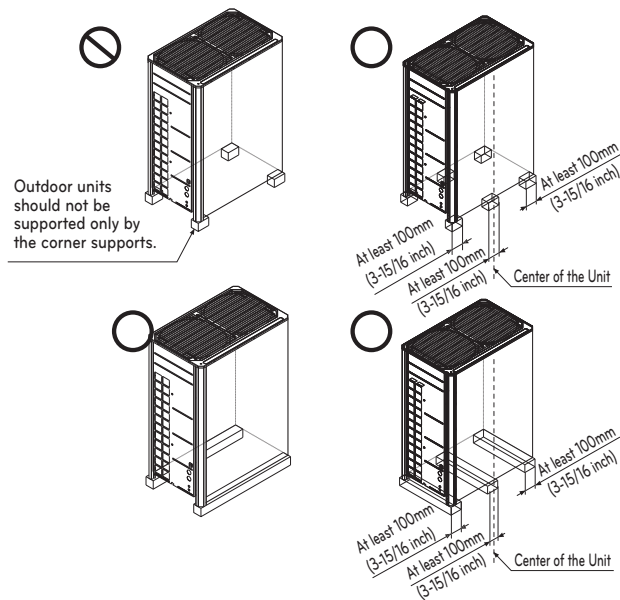

The location of the Anchor bolts

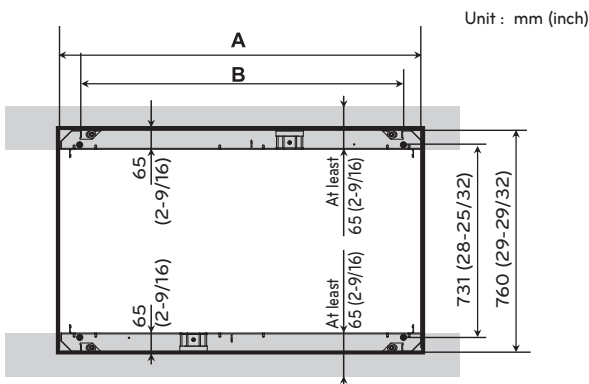

Chassis	A [mm (inch)]	B [mm (inch)]
UXA	930 (36-5/8)	748 (29-9/20)
UXB	1240 (47-1/4)	1040 (40-15/16)

Foundation for Installation

- Fix the unit tightly with bolts as shown below so that unit will not fall down due to earthquake or gust.
- Use the H-beam support as a base support
- Noise and vibration may occur from the floor or wall since vibration is transferred through the installation part depending on installation status. Thus, use anti-vibration materials (cushion pad) fully (The base pad shall be more than 200 mm (7-7/8 inch)).

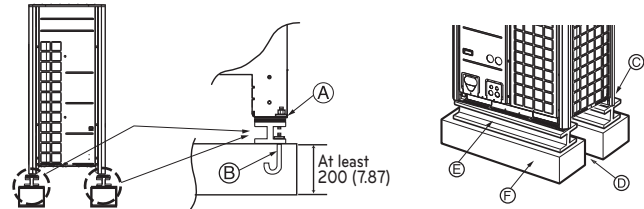

- Ⓐ The corner part must be fixed firmly. Otherwise, the support for the installation may be bent.
- Ⓑ Get and use M10 Anchor bolt.
- Ⓒ Put Cushion Pad between the outdoor unit and ground support for the vibration protection in wide area.
- Ⓓ Space for pipes and wiring (Pipes and wirings for bottom side)
- Ⓔ H-beam support
- Ⓕ Concrete support

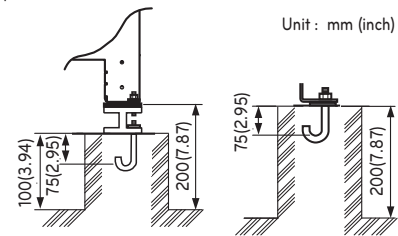

WARNING

- Install where it can sufficiently support the weight of the outdoor unit. If the support strength is not enough, the outdoor unit may drop and hurt people.
- Install where the outdoor unit may not fall in strong wind or earthquake. If there is a fault in the supporting conditions, the outdoor unit may fall and hurt people.
- Please take extra cautions on the supporting strength of the ground, water outlet treatment (treatment of the water flowing out of the outdoor unit in operation), and the passages of the pipe and wiring, when making the ground support.
- Do not use tube or pipe for water outlet in the Base panel. Use drainage instead for water outlet. The tube or pipe may freeze and the water may not be drained.

CAUTION

- Be sure to remove the Pallet (Wood Support) of the bottom side of the outdoor unit Base panel before fixing the bolt. It may cause the unstable state of the outdoor settlement, and may cause freezing of the heat exchanger resulting in abnormal operations.
- Be sure to remove the Pallet (Wood Support) of the bottom side of the outdoor unit before welding. Not removing Pallet (Wood Support) causes hazard of fire during welding.

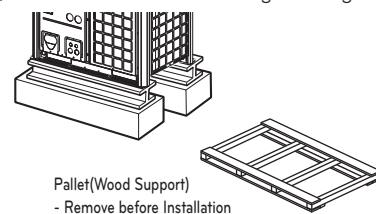

Preparation of Piping

Main cause of gas leakage is defect in flaring work. Carry out correct flaring work in the following procedure.

Cut the pipes and the cable

- Use the accessory piping kit or the pipes purchased locally.
- Measure the distance between the indoor and the outdoor unit.
- Cut the pipes a little longer than measured distance.
- Cut the cable 1.5 m (4.92 ft) longer than the pipe length.

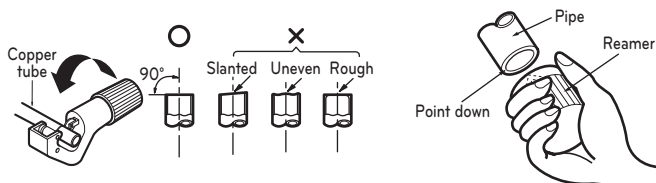

Burrs removal

- Completely remove all burrs from the cut cross section of pipe/tube.
- Put the end of the copper tube/pipe to downward direction as you remove burrs in order to avoid to let burrs drop in the tubing.

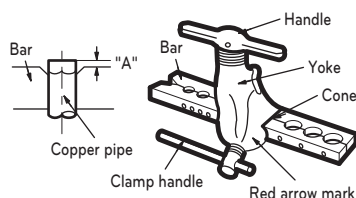

Flaring work

- Carry out flaring work using flaring tool as shown below.

Indoor unit [kW(Btu/h)]	Pipe(mm(inch))		'A'(mm(inch))	
	Gas	Liquid	Gas	Liquid
<5.6(19,100)	Ø12.7 (1/2)	Ø6.35 (1/4)	0.5~0.8 (0.02~0.03)	0~0.5 (0~0.02)
<16.0(54,600)	Ø15.88 (5/8)	Ø9.52 (3/8)	0.8~1.0 (0.03~0.04)	0.5~0.8 (0.02~0.03)
<22.4(76,400)	Ø19.05 (3/4)	Ø9.52 (3/8)	1.0~1.3 (0.04~0.05)	0.5~0.8 (0.02~0.03)

Firmly hold copper tube in a bar(or die) as indicated dimension in the table above.

Check

- Compare the flared work with figure below.
- If flare is noted to be defective, cut off the flared section and do flaring work again.

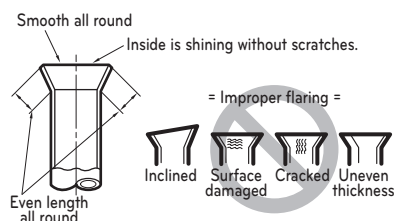

Flare shape and flare nut tightening torque

Precautions when connecting pipes

- See the following table for flare part machining dimensions.
- When connecting the flare nuts, apply refrigerant oil to the inside and outside of the flares and turn them three or four times at first. (Use ester oil or ether oil.)
- See the following table for tightening torque.(Applying too much torque may cause the flares to crack.)
- After all the piping has been connected, use nitrogen to perform a gas leak check.

Pipe size [mm (inch)]	Tightening Torque N·m (lbs·ft)	A [mm (inch)]	Flare shape
Ø9.52 (3/8)	38±4 (28±3.0)	12.8 (0.5)~13.2 (0.52)	
Ø12.7 (1/2)	55±6 (41±4.4)	16.2 (0.64)~16.6 (0.65)	
Ø15.88 (5/8)	75±7 (55±5.2)	19.3 (0.76)~19.7(0.78)	

CAUTION

- Always use a charge hose for service port connection.
- After tightening the cap, check that no refrigerant leaks are present.
- When loosening a flare nut, always use two wrenches in combination, When connecting the piping, always use a spanner and torque wrench in combination to tighten the flare nut.
- When connecting a flare nut, coat the flare(inner and outer faces) with oil for R410A(PVE) and hand tighten the nut 3 to 4 turns as the initial tightening.

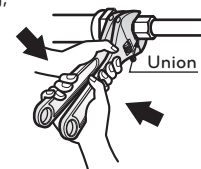

Opening shutoff valve

- 1 Remove the cap and turn the valve counter clockwise with the hexagon wrench.
- 2 Turn it until the shaft stops.
Do not apply excessive force to the shutoff valve. Doing so may break the valve body, as the valve is not a backseat type. Always use the special tool.
- 3 Make sure to tighten the cap securely.

Closing shutoff valve

- 1 Remove the cap and turn the valve clockwise with the hexagon wrench.
- 2 Securely tighten the valve until the shaft contacts the main body seal.
- 3 Make sure to tighten the cap securely.
* For the tightening torque, refer to the table on the below.

Tightening torque

Shut off valve size (mm (inch))	Tightening torque N·m (lbs·ft) (Turn clockwise to close)					
	Shaft (valve body)		Hexagonal wrench	Cap (Valve lid)	Service port	Flare nut
Closed	Opened					
Ø6.35 (1/4)	6.0±0.6 (4.4±0.4)	5.0±0.0 (3.7±0.4)	4 mm (0.16 inch)	17.6±2.0 (13.0±1.5)	12.7±2 (9.4±1.5)	16±2 (12±1.5)
Ø9.52 (3/8)						38±4 (28±3.0)
Ø12.7 (1/2)	10.0±1.0 (7.4±0.7)	5.0±0.0 (3.7±0.4)	5 mm (0.24 inch)	20.0±2.0 (14.8±1.5)	12.7±2 (9.4±1.5)	55±6 (41±4.4)
Ø15.88 (5/8)	12.0±1.2 (8.9±0.9)					75±7 (55±5.1)
Ø19.05 (3/4)	14.0±1.4 (10.3±1.0)	5.0±0.0 (3.7±0.4)	5 mm (0.24 inch)	25.0±2.5 (18.4±1.8)	12.7±2 (9.4±1.5)	110±10 (81.1±7.4)
Ø22.2 (7/8)	30.0±3.0 (22.1±2.2)					25±3 (18.5±2.2)
Ø25.4 (1)	30.0±3.0 (22.1±2.2)	5.0±0.0 (3.7±0.4)	8 mm (0.31 inch)	25.0±2.5 (18.4±1.8)	12.7±2 (9.4±1.5)	25±3 (18.5±2.2)

Insulation of shutoff valve

- 1 Use the heat insulation material for the refrigerant piping which has an excellent heat-resistance (over 120 °C [248 °F]).

2 Precautions in high humidity circumstance:
 This air conditioner has been tested according to the "ISO Conditions with Mist" and confirmed that there is not any default. However, if it is operated for a long time in high humid atmosphere (dew point temperature: More than 23 °C [73.4 °F]), water drops are liable to fall. In this case, add heat insulation material according to the following procedure:

- Heat insulation material to be prepared: EPDM (Ethylene Propylene Diene Methylene)-over 120 °C [248 °F] the heat-resistance temperature.
- Add the insulation over 10 mm [0.39 inch] thickness at high humidity environment.

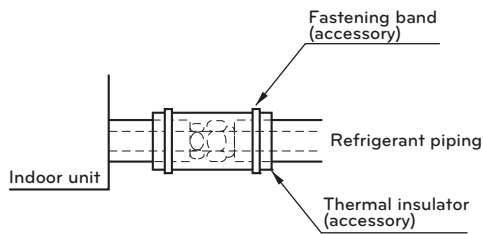

Plumbing materials and storage methods

Pipe must be able to obtain the specified thickness and should be used with low impurities. Also when handling storage, pipe must be careful to prevent a fracture, deformity and wound. Should not be mixed with contaminations such as dust, moisture.

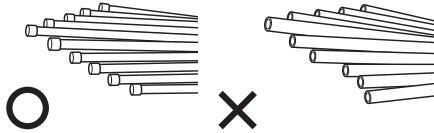

Refrigerant piping on three principles

	Drying	Cleanliness	Airtight
	Should be no moisture inside	No dust inside.	There is no refrigerant leakage
Items			
Cause failure	<ul style="list-style-type: none"> - Significant hydrolysis of refrigerant oil - Degradation of refrigerant oil - Poor insulation of the compressor - Do not cold and warm - Clogging of EEV, Capillary 	<ul style="list-style-type: none"> - Degradation of refrigerant oil - Poor insulation of the compressor - Do not cold and warm - Clogging of EEV, Capillary 	<ul style="list-style-type: none"> - Gas shortages - Degradation of refrigerant oil - Poor insulation of the compressor - Do not cold and warm
Countermeasure	<ul style="list-style-type: none"> - No moisture in the pipe - Until the connection is completed, the plumbing pipe entrance should be strictly controlled. - Stop plumbing at rainy day. - Pipe entrance should be taken side or bottom. - When removal burr after cutting pipe, pipe entrance should be taken down. - Pipe entrance should be fitted cap when pass through the walls. 	<ul style="list-style-type: none"> - No dust in the pipe. - Until the connection is completed, the plumbing pipe entrance should be strictly controlled. - Pipe entrance should be taken side or bottom. - When removal burr after cutting pipe, pipe entrance should be taken down. - Pipe entrance should be fitted cap when pass through the walls. 	<ul style="list-style-type: none"> - Airtightness test should be. - Brazing operations to comply with standards. - Flare to comply with standards. - Flange connections to comply with standards.

Nitrogen substitution method

Welding, as when heating without nitrogen substitution a large amount of the oxide film is formed on the internal piping.

The oxide film is caused by clogging EEV, Capillary, oil hole of accumulator and suction hole of oil pump in compressor.

It prevents normal operation of the compressor.

In order to avoid this problem, Welding should be done after replacing air by nitrogen gas.

When welding plumbing pipe, the work is required.

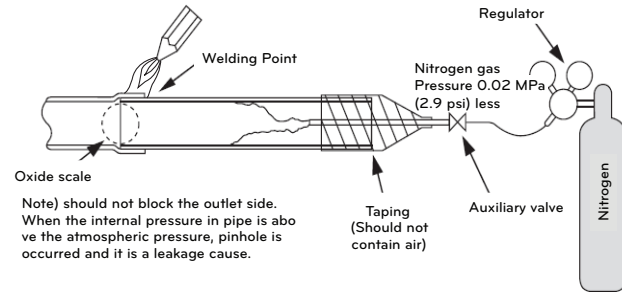

CAUTION

- Always use the nitrogen.(not use oxygen, carbon dioxide, and a Chevron gas): Please use the following nitrogen pressure 0.02 MPa (2.9 psi) Oxygen - Promotes oxidative degradation of refrigerant oil. Because it is flammable, it is strictly prohibited to use Carbon dioxide - Degrade the drying characteristics of gas Chevron Gas - Toxic gas occurs when exposed to direct flame.
- Always use a pressure reducing valve.
- Please do not use commercially available antioxidant. The residual material seems to be the oxide scale is observed. In fact, due to the organic acids generated by oxidation of the alcohol contained in the anti-oxidants, ants nest corrosion occurs. (causes of organic acid → alcohol + copper + water + temperature)

REFRIGERANT PIPING INSTALLATION

For Heat Pump System Installation

Precautions on Pipe connection / Valve operation

Pipe connection is done by connecting from the end of the pipe to the branching pipes, and the refrigerant pipe coming out of the outdoor unit is divided at the end to connect to each indoor unit. Flare connection for the indoor unit, and welding connection for the outdoor pipe and the branching parts.

- Use hexagonal wrench to open/close the valve.
- * In case of the heat pump system installation, be sure to maintain to close no use pipe like below picture.
- * Refer to the accessory installation manual provided.

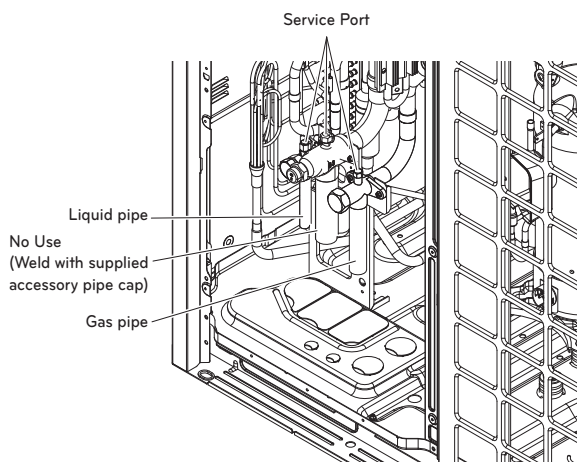

WARNING

- Always careful not to leak the refrigerant during welding.
- The refrigerant generates poisonous gas harmful to human body if combusted.
- Do not perform welding in a closed space.
- Be sure to close the cap of the service port to prevent gas leakage after the work.

CAUTION

Please block the pipe knock outs of the front and side panels after installing the pipes. (Animals or foreign objects may be brought in to damage wires.)

Connection of Outdoor units

When installing ODU series, refer below picture.

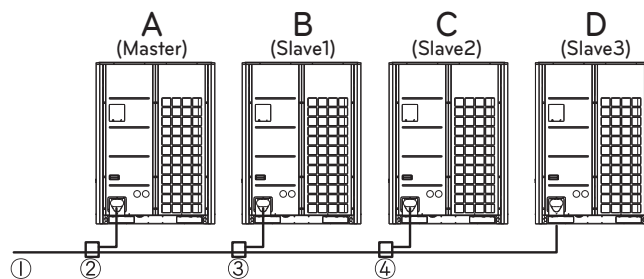

- A ≥ B ≥ C ≥ D (Capability)
- ① IDU side connection pipe
 - ② ODU to ODU connection pipe (1st branch)
 - ③ ODU to ODU connection pipe (2st branch)
 - ④ ODU to ODU connection pipe (3rd branch)

2, 3, 4 Outdoor Units

Outdoor units	Model	Liquid Pipe	Gas Pipe
2 Unit	ARCNN21		
3 Unit	ARCNN31		
4 Unit	ARCNN41		

For more information, refer accessory installation manual.

Y branch

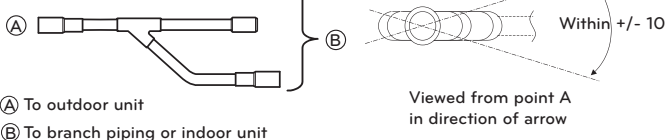

- Ⓐ To outdoor unit
- Ⓑ To branch piping or indoor unit

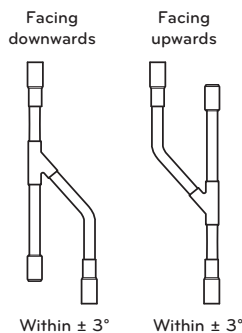

Caution

- Use the following materials for refrigerant piping.
 - Material: Seamless phosphorous deoxidized copper pipe
 - Wall thickness : Comply with the relevant local and national regulations for the designed pressure 3.8 MPa (551 psi). We recommend the following table as the minimum wall thickness.

Outer diameter [mm][inch]	6.35 (1/4)	9.52 (3/8)	12.7 (1/2)	15.88 (5/8)	19.05 (3/4)	22.2 (7/8)	25.4 (1)	28.58 (1-1/8)	31.8 (1-1/4)	34.9 (1-3/8)	38.1 (1-1/2)	41.3 (1-5/8)	44.45 (1-3/4)	53.98 (2-1/8)
Minimum thickness [mm][inch]	0.8 (0.03)	0.8 (0.03)	0.8 (0.03)	0.99 (0.04)	0.99 (0.04)	0.99 (0.04)	0.99 (0.04)	0.99 (0.04)	1.1 (0.04)	1.21 (0.05)	1.35 (0.05)	1.43 (0.06)	1.55 (0.06)	2.1 (0.08)

- Commercially available piping often contains dust and other materials. Always blow it clean with a dry inert gas.
- Use care to prevent dust, water or other contaminants from entering the piping during installation.
- Reduce the number of bending portions as much as possible, and make bending radius as big as possible.
- Always use the branch piping set shown below, which are sold separately.

Y branch	Header		
	4 branches	7 branches	10 branches
ARBLB01621, ARBLB03321, ARBLB07121, ARBLB14521, ARBLB23220	ARBL054	ARBL057	ARBL1010
	ARBL104	ARBL107	ARBL2010

- If the diameters of the branch piping of the designated refrigerant piping differs, use a pipe cutter to cut the connecting section and then use an adapter for connecting different diameters to connect the piping.
- Always observe the restrictions on the refrigerant piping (such as rated length, difference in height, and piping diameter). Failure to do so can result in equipment failure or a decline in heating/cooling performance.
- A second branch cannot be made after a header. (These are shown by ⊗.)

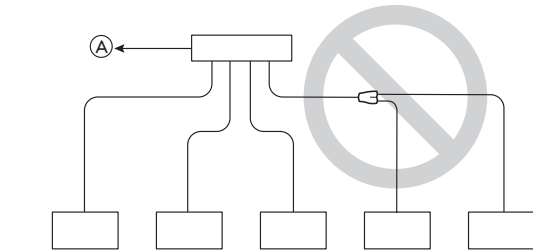

Ⓐ To Outdoor Unit
Ⓑ Sealed Piping

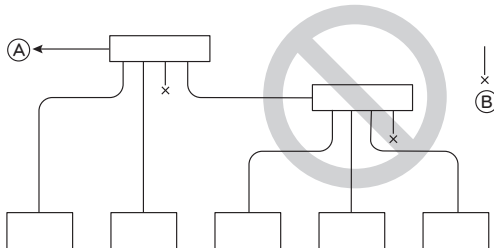

- The Multi V will stop due to an abnormality like excessive or insufficient refrigerant. At such a time, always properly charge the unit. When servicing, always check the notes concerning both the piping length and the amount of additional refrigerant.
- Never perform a pump down. This will not only damage the compressor but also deteriorate the performance.
- Never use refrigerant to perform an air purge. Always evacuate air by using a vacuum pump.
- Always insulate the piping properly. Insufficient insulation will result in a decline in heating/cooling performance, drip of condensate and other such problems.
- When connecting the refrigerant piping, make sure the service valves of the Outdoor Unit is completely closed (the factory setting) and do not operate it until the refrigerant piping for the Outdoor and Indoor Units has been connected, a refrigerant leakage test has been performed and the evacuation process has been completed.
- Always use a non-oxidizing brazing material for brazing the parts and do not use flux. If not, oxidized film can cause clogging or damage to the compressor unit and flux can harm the copper piping or refrigerant oil.

! WARNING

When installing and moving the air conditioner to another site, be sure to make recharge refrigerant after perfect evacuation.

- If a different refrigerant or air is mixed with the original refrigerant, the refrigerant cycle may malfunction and the unit may be damaged.
- After selecting diameter of the refrigerant pipe to suit total capacity of the indoor unit connected after branching, use an appropriate branch pipe set according to the pipe diameter of the indoor unit and the installation pipe drawing.

For Heat Recovery System Installation

Precautions on Pipe connection / Valve operation

Pipe connection is done by connecting from the end of the pipe to the branching pipes, and the refrigerant pipe coming out of the outdoor unit is divided at the end to connect to each indoor unit. Flare connection for the indoor unit, and welding connection for the outdoor pipe and the branching parts.

- Use hexagonal wrench to open/close the valve.

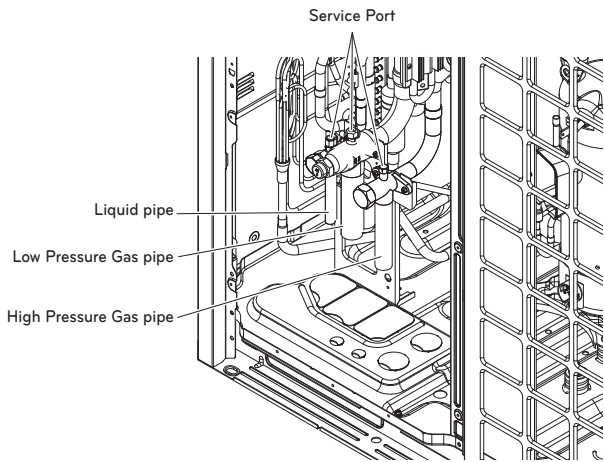

WARNING

- Always careful not to leak the refrigerant during welding.
- The refrigerant generates poisonous gas harmful to human body if combusted.
- Do not perform welding in a closed space.
- Be sure to close the cap of the service port to prevent gas leakage after the work.

CAUTION

Please block the pipe knock outs of the front and side panels after installing the pipes.
(Animals or foreign objects may be brought in to damage wires.)

Connection of Outdoor units

When installing ODU series, refer below picture.

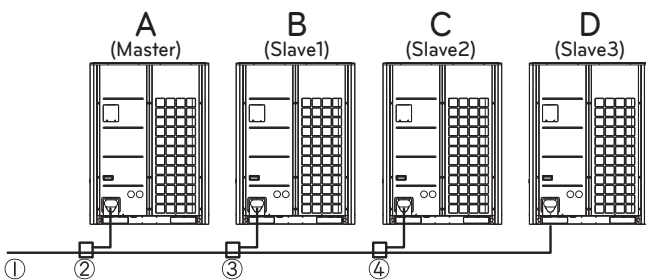

$A \geq B \geq C \geq D$ (Capability)

- ① IDU side connection pipe
- ② ODU to ODU connection pipe (1st branch)
- ③ ODU to ODU connection pipe (2st branch)
- ④ ODU to ODU connection pipe (3rd branch)

2, 3, 4 Outdoor Units

Outdoor units	Model	Low Pressure Gas Pipe	Liquid Pipe	High Pressure Gas Pipe
2 Unit	ARC�B21			
3 Unit	ARC�B31			
4 Unit	ARC�B41			

For more information, refer accessory installation manual.

Y branch

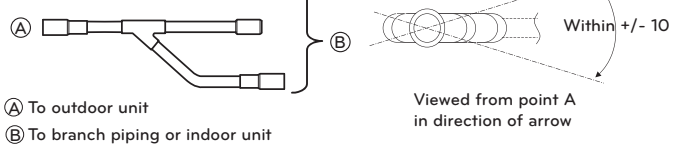

Facing downwards

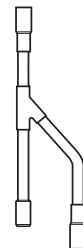

Facing upwards



Installation procedure for HR unit

- 1 Using an insert-hole-in- anchor, hang the hanging bolt.
- 2 Install a hexagon nut and a flat washer (locally-procured)to the hanging bolt as shown in the figure in the bottom, and fit the main unit to hang on the hanger metal.
- 3 After checking with a level that the unit is level, tighten the hexagon nut.
* The tilt of the unit should be within ±5° in front/back and left/right.
- 4 This unit should be installed suspended from ceiling and side A should always be facing up.
- 5 Insulate not used pipes completely as shown in the figure.

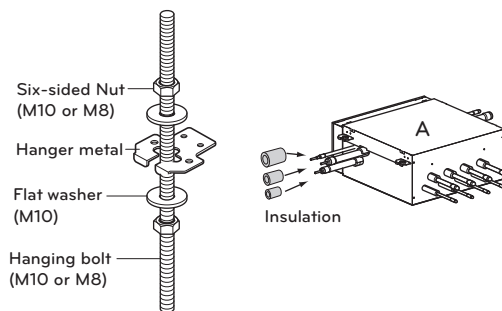

Installation of Outdoor Unit, HR Unit, Indoor Unit Refrigerant Pipe

3 pipes are connected to the HR unit from the outdoor unit, classified into liquid pipe, low pressure gas pipe and high pressure gas pipe depending on status of refrigerant passing through the pipe.

You must connect 3 pipes from outdoor unit to HR unit.

For connection between indoor unit and HR unit, you must connect both liquid pipe and gas pipe from the HR unit to the indoor unit. In this case, connect them to the indoor unit starting from No.1 connection port of the HR unit (the port number is displayed on ports of the HR unit). Use auxiliary flare as annexed parts in connection to the indoor unit.

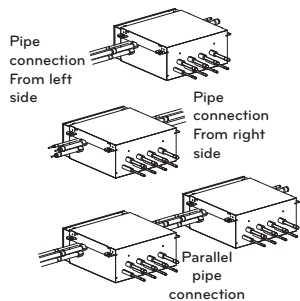
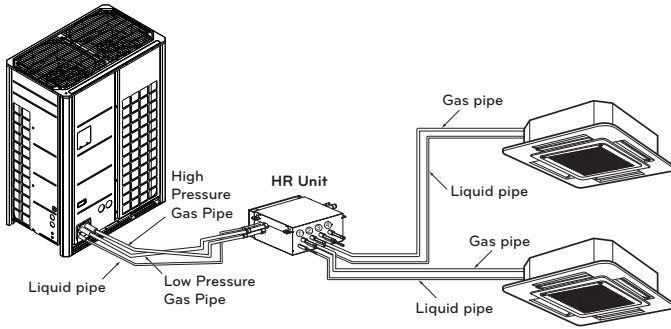

CAUTION

Whenever connecting the indoor units with the HR unit, install the indoor units in numerical order from No.1.

Ex) In case of installing 3 indoor units : No. 1, 2, 3 (O), No. 1, 2, 4 (X), No.1, 3, 4 (X), No.2, 3, 4 (X).

Type of HR Unit

Select an HR unit according to the number of the indoor units to be installed. HR units are classified into 3 types by the number of connectable indoor units.

Ex) Installation of 6 indoor units
Consists of HR unit for 4 branches and HR unit for 2 branches.

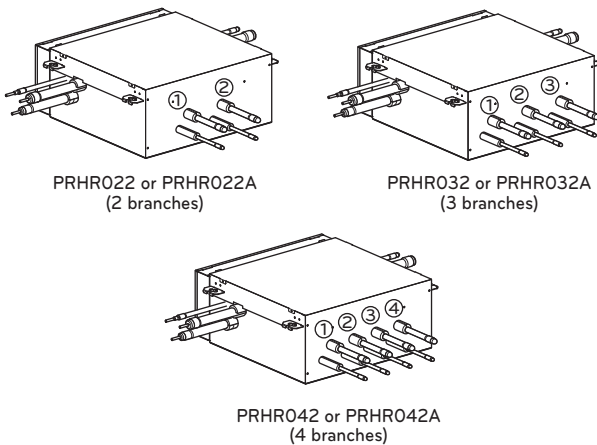

Joint Method of HR Unit (Big Duct : ARNU76GB8-, ARNU763B8-, ARNU96GB8-, ARNU963B8-)

Joint Method is required when the big duct chassis is installed. In Joint Method, two neighboring outlets of one HR unit are linked by Y branch pipe and connected to one indoor unit.

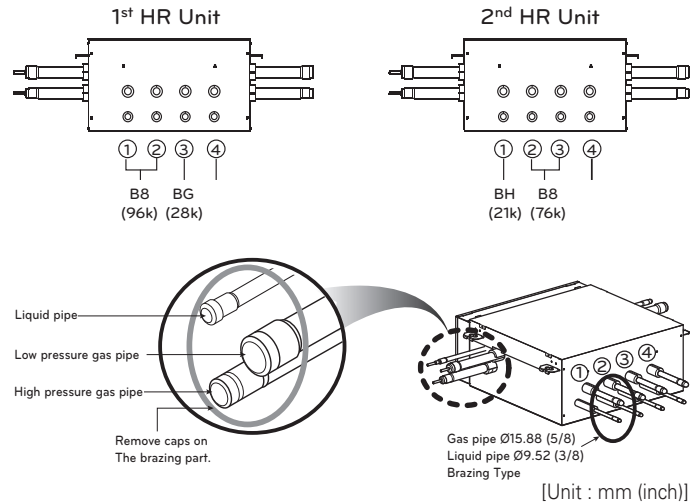

[Unit : mm (inch)]

HR unit	PRHR022 PRHR022A	PRHR032 PRHR032A	PRHR042 PRHR042A
Low pressure gas pipe	Ø22.2 (7/8)	Ø28.58 (1-1/8)	Ø28.58 (1-1/8)
High pressure gas pipe	Ø19.05 (3/4)	Ø22.2 (7/8)	Ø22.2 (7/8)
Liquid pipe	Ø9.52 (3/8)	Ø12.7 (1/2)	Ø15.88 (5/8)

Installation of Zoning Control

Some indoor unit can be connected to one port of HR unit.

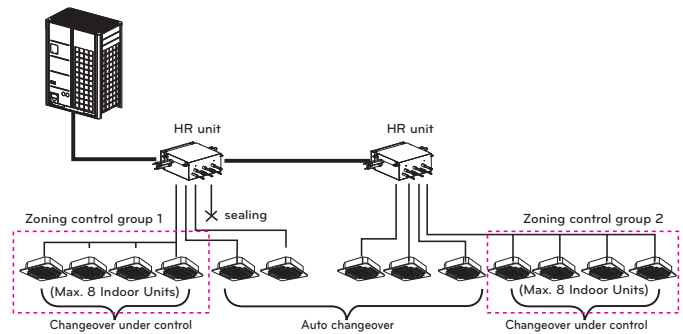







WARNING

- A branch pipe of HR unit allows up to 14.1 kW (48 kBtu/h) based on cooling capacity of the indoor unit. (up to 14.1kW (48kBtu/h) for max installation)
- The maximum total capacity of indoor units connected to a PRHR042 or PRHR042A HR unit is 56.4kW (192 kBtu/h).
- The maximum number of indoor units connected to a PRHR042 or PRHR042A HR unit are 32 indoor units. (The Maximum indoor units per a branch pipe of HR unit are 8 indoor units)
- There is not operate "Auto-changeover" & "Mode override" function in the zoning group.
- When there are operating indoor units on cooling(heating) mode, another indoor units aren't changed on heating(cooling) mode in the zoning group.

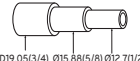
[Reducers for indoor unit and HR unit]

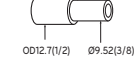
Unit : mm (inch)

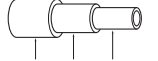
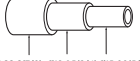
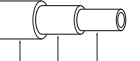
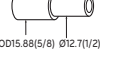
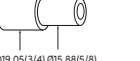
Models	Liquid pipe	Gas pipe	
		High pressure	Low pressure
Indoor unit reducer	 OD9.52(3/8) Ø6.35(1/4)	-	 OD15.88(5/8) Ø12.7(1/2)
HR unit reducer	 OD9.52(3/8) Ø6.35(1/4)	 OD19.05(3/4) Ø15.88(5/8) Ø12.7(1/2)	 OD22.2(7/8) Ø19.05(3/4) Ø15.88(5/8)
		 Ø12.7(1/2) Ø9.52(3/8)	 Ø15.88(5/8) Ø12.7(1/2)
PRHR032, PRHR042, PRHR032A, PRHR042A	 OD15.88(5/8) Ø12.7(1/2) Ø9.52(3/8)	 OD22.2(7/8) Ø19.05(3/4) Ø15.88(5/8)	 OD28.58(1-1/8) Ø22.2(7/8) Ø19.05(3/4)
		 OD15.88(5/8) Ø12.7(1/2)	 OD19.05(3/4) Ø15.88(5/8)

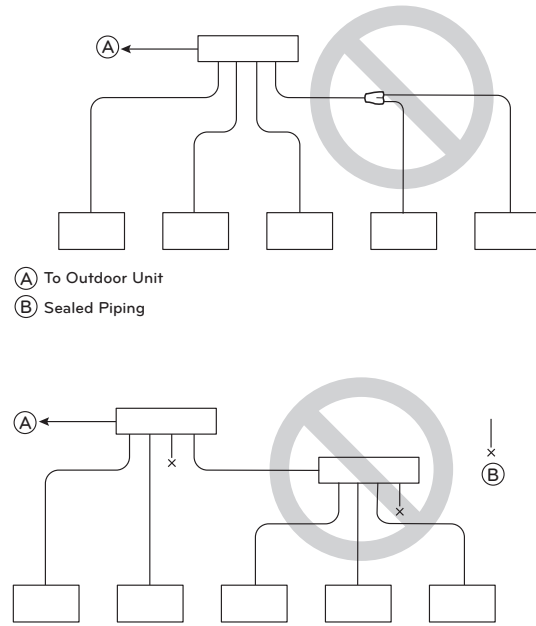

Caution

- Use the following materials for refrigerant piping.
 - Material: Seamless phosphorous deoxidized copper pipe
 - Wall thickness : Comply with the relevant local and national regulations for the designed pressure 3.8 MPa (551 psi). We recommend the following table as the minimum wall thickness.

Outer diameter [mm(inch)]	6.35 (1/4)	9.52 (3/8)	12.7 (1/2)	15.88 (5/8)	19.05 (3/4)	22.2 (7/8)	25.4 (1)	28.58 (1-1/8)	31.8 (1-1/4)	34.9 (1-3/8)	38.1 (1-1/2)	41.3 (1-5/8)	44.45 (1-3/4)	53.98 (2-1/8)
Minimum thickness [mm(inch)]	0.8 (0.03)	0.8 (0.03)	0.8 (0.03)	0.99 (0.04)	0.99 (0.04)	0.99 (0.04)	0.99 (0.04)	0.99 (0.04)	1.1 (0.04)	1.21 (0.05)	1.35 (0.05)	1.43 (0.06)	1.55 (0.06)	2.1 (0.08)

- Commercially available piping often contains dust and other materials. Always blow it clean with a dry inert gas.
- Use care to prevent dust, water or other contaminants from entering the piping during installation.
- Reduce the number of bending portions as much as possible, and make bending radius as big as possible.
- Always use the branch piping set shown below, which are sold separately.

Y branch	Header		
	4 branches	7 branches	10 branches
ARBLB01621, ARBLB03321, ARBLB07121, ARBLB14521, ARBLB23220	ARBL054	ARBL057	ARBL1010
	ARBL104	ARBL107	ARBL2010

- If the diameters of the branch piping of the designated refrigerant piping differs, use a pipe cutter to cut the connecting section and then use an adapter for connecting different diameters to connect the piping.
- Always observe the restrictions on the refrigerant piping (such as rated length, difference in height, and piping diameter). Failure to do so can result in equipment failure or a decline in heating/cooling performance.
- A second branch cannot be made after a header. (These are shown by ⊘.)

- The Multi V will stop due to an abnormality like excessive or insufficient refrigerant. At such a time, always properly charge the unit. When servicing, always check the notes concerning both the piping length and the amount of additional refrigerant.
- Never perform a pump down. This will not only damage the compressor but also deteriorate the performance.
- Never use refrigerant to perform an air purge. Always evacuate air by using a vacuum pump.
- Always insulate the piping properly. Insufficient insulation will result in a decline in heating/cooling performance, drip of condensate and other such problems.
- When connecting the refrigerant piping, make sure the service valves of the Outdoor Unit is completely closed (the factory setting) and do not operate it until the refrigerant piping for the Outdoor and Indoor Units has been connected, a refrigerant leakage test has been performed and the evacuation process has been completed.
- Always use a non-oxidizing brazing material for brazing the parts and do not use flux. If not, oxidized film can cause clogging or damage to the compressor unit and flux can harm the copper piping or refrigerant oil.

WARNING

When installing and moving the air conditioner to another site, be sure to make recharge refrigerant after perfect evacuation.

- If a different refrigerant or air is mixed with the original refrigerant, the refrigerant cycle may malfunction and the unit may be damaged.
- After selecting diameter of the refrigerant pipe to suit total capacity of the indoor unit connected after branching, use an appropriate branch pipe set according to the pipe diameter of the indoor unit and the installation pipe drawing.

PIPE CONNECTIONS BETWEEN INDOOR AND OUTDOOR UNIT

- Pipe connections can be done on the front side or on the side according to the installation environments.
- Be sure to let 0.2 kgf/cm² (2.8 psi) Nitrogen flow in the pipe when welding.
- If Nitrogen was not flown during welding, many oxidized membranes may form inside the pipe and disturb the normal operations of valves and condensers.

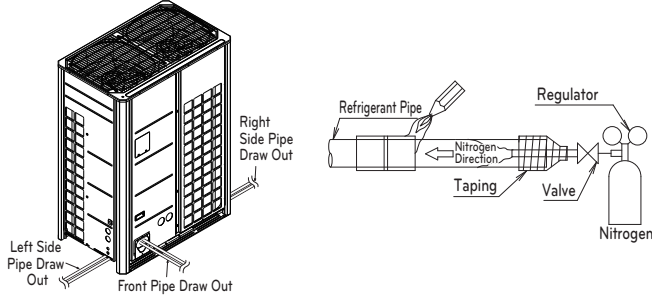

Remove leakage prevention cap

- Remove the leakage prevention cap attached to the outdoor unit service valve before pipe work.
- Proceed the leakage prevention cap removal as follows:
 - Verify whether all the pipes are locked.
 - Extract remaining refrigerant or air inside using the service port.
 - Remove the leakage prevention cap

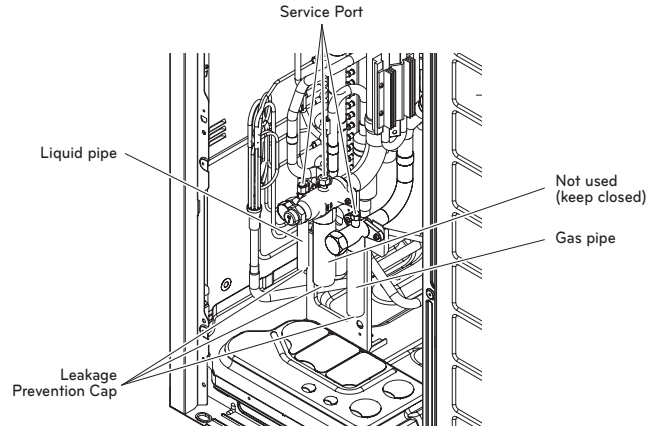

For Heat Pump System Installation

Preparation Work

- Use Knock Outs of Base Pan of the outdoor unit for Left/Right or Bottom pipe drawing outs.

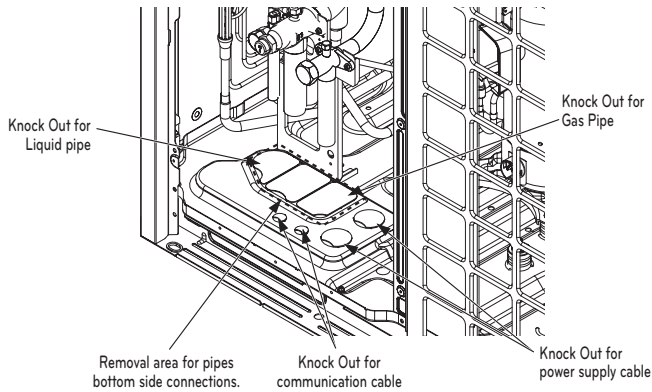

CAUTION

- Do not give damage to the pipe/base during the Knock Out work.
- Proceed to pipe work after removing burr after Knock Out work.
- Perform sleeve work to prevent damage to the wire when connecting wires using Knock Outs.

Pipe Drawing Out during Single / Series connection

Method of drawing out pipes on the front side

- Proceed with the pipe work as shown in the below figure for front side pipe drawing out.

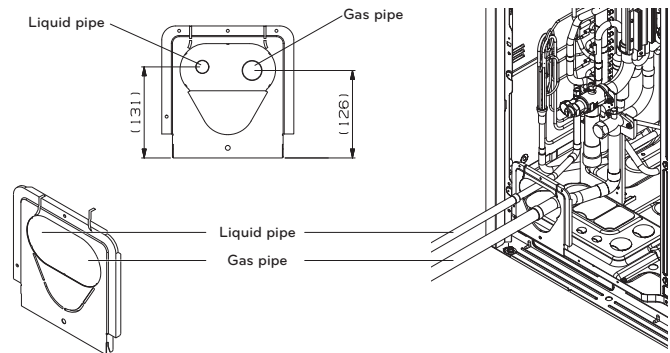

Chassis	UXA			UXB		
A						
B						
C						
HP	8	10	12	14/16	18/20/22	24/26
A(mm)	9.52(3/8)	9.52(3/8)	12.7(1/2)	12.7(1/2)	15.88(5/8)	15.88(5/8)
B(mm)	19.05(3/4)	22.2(7/8)	28.58(1-1/8)	28.58(1-1/8)	28.58(1-1/8)	34.9(1-3/8)
C(mm)	19.05(3/4)	19.05(3/4)	19.05(3/4)	22.2(7/8)	22.2(7/8)	28.58(1-1/8)

* Elbow is Field supplied

* Elbow size are same as Pipe 'A', 'C'.

Method of drawing out pipes on the bottom side

- Drawing out common pipe through side panel

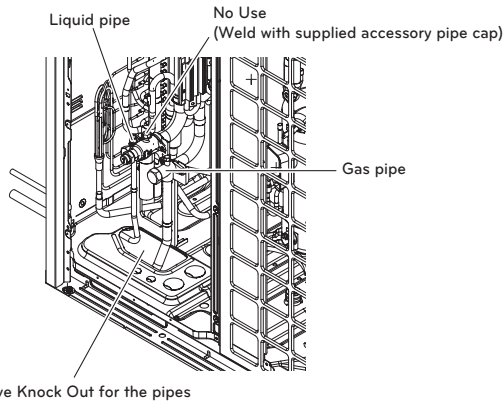

* Please weld with the proper Low pressure Gas pipe included with product.

Refrigerant piping system

1 Outdoor Units

Y branch method

- (A) : Outdoor Unit
- (B) : 1st branch (Y branch)
- (C) : Indoor Units

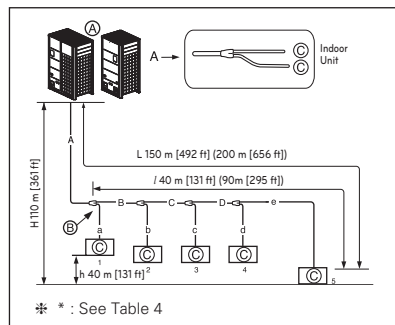

* : See Table 4

Combination of Y branch/header Method

- (A) : Outdoor Unit
- (B) : 1st branch (Y branch)
- (C) : Y branch
- (D) : Indoor Unit
- (E) : Header
- (F) : Sealed piping

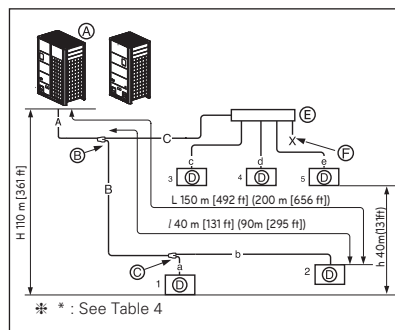

* : See Table 4

Header Method

- (A) : Outdoor Unit
- (C) : Indoor Units
- (D) : Sealed piping
- (E) : Header

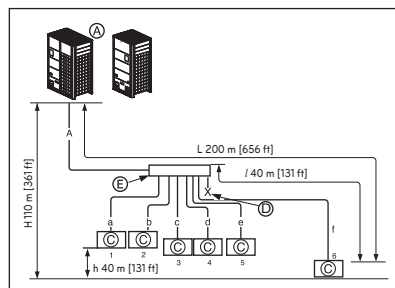

Series Outdoor Units (2 Units ~ 4 Units)

Y branch method

- (A) : Outdoor Unit
- (B) : 1st branch (Y branch)
- (C) : Indoor Units
- (E) : Connection branch pipe between Outdoor units : ARCNN41
- (F) : Connection branch pipe between Outdoor units : ARCNN31
- (G) : Connection branch pipe between Outdoor units : ARCNN21

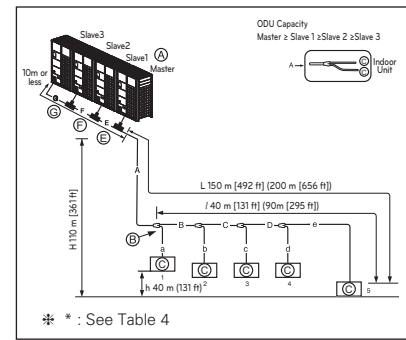

* : See Table 4

Combination of Y branch/header Method

- (A) : Outdoor Unit
- (B) : 1st branch (Y branch)
- (C) : Y branch
- (D) : Indoor Unit
- (E) : Connection branch pipe between Outdoor units : ARCNN41
- (F) : Connection branch pipe between Outdoor units : ARCNN31
- (G) : Connection branch pipe between Outdoor units : ARCNN21
- (H) : Header
- (I) : Sealed piping

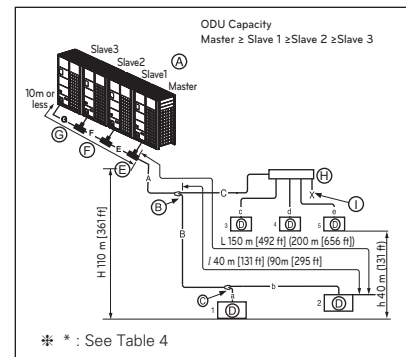

* : See Table 4

Header Method

- (A) : Outdoor Unit
- (B) : Header branch
- (C) : Indoor Units
- (D) : Sealed piping
- (E) : Connection branch pipe between Outdoor units : ARCNN41
- (F) : Connection branch pipe between Outdoor units : ARCNN31
- (G) : Connection branch pipe between Outdoor units : ARCNN21

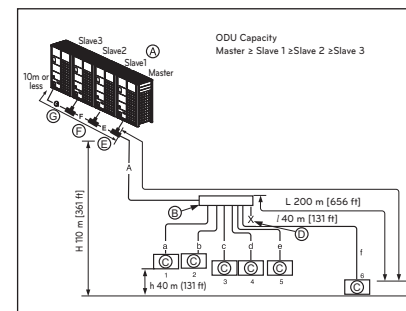

For Heat Recovery System Installation

Preparation Work

- Use Knock Outs of Base Pan of the outdoor unit for Left/Right or Bottom pipe drawing outs.

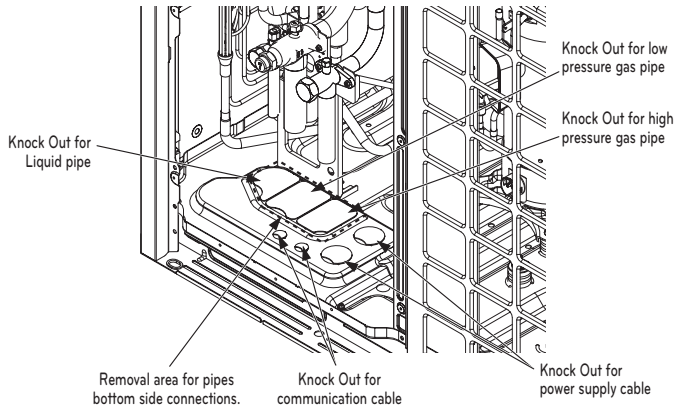

CAUTION

- Do not give damage to the pipe/base during the Knock Out work.
- Proceed to pipe work after removing burr after Knock Out work.
- Perform sleeve work to prevent damage to the wire when connecting wires using Knock Outs.

Remove leakage prevention cap

- Remove the leakage prevention cap attached to the outdoor unit service valve before pipe work.
- Proceed the leakage prevention cap removal as follows:
 - Verify whether the liquid/gas pipes are locked.
 - Extract remaining refrigerant or air inside using the service port.
 - Remove the leakage prevention cap

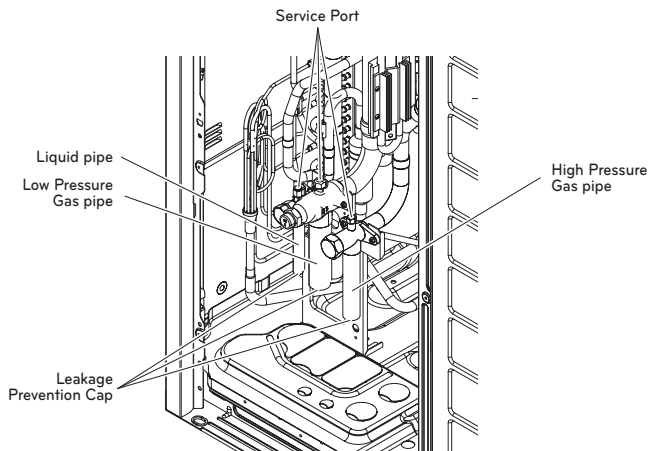

Pipe Drawing Out during Single / Series connection

Method of drawing out pipes on the front side

- Proceed with the pipe work as shown in the below figure for front side pipe drawing out.

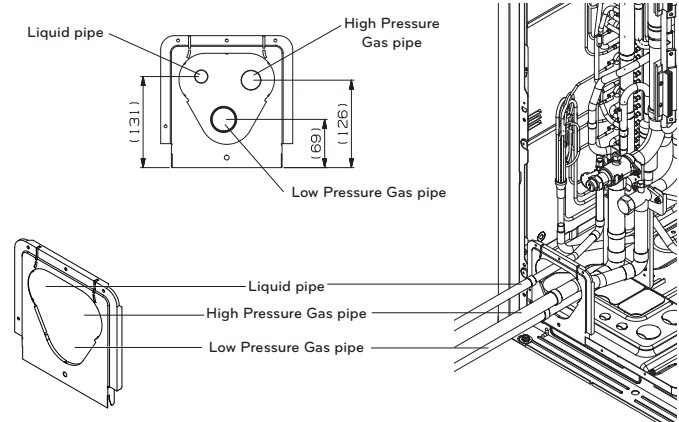

Chassis	UXA			UXB		
A						
B						
C						
HP	8	10	12	14/16	18/20/22	24/26
A(mm)	9.52(3/8)	9.52(3/8)	12.7(1/2)	12.7(1/2)	15.88(5/8)	15.88(5/8)
B(mm)	19.05(3/4)	22.2(7/8)	28.58 (1-1/8)	28.58 (1-1/8)	28.58 (1-1/8)	34.9 (1-3/8)
C(mm)	19.05(3/4)	19.05(3/4)	19.05(3/4)	22.2(7/8)	22.2(7/8)	28.58 (1-1/8)

* Elbow is Field supplied

* Elbow size are same as Pipe 'A', 'B', 'C'.

Method of drawing out pipes on the bottom side

- Drawing out common pipe through side panel

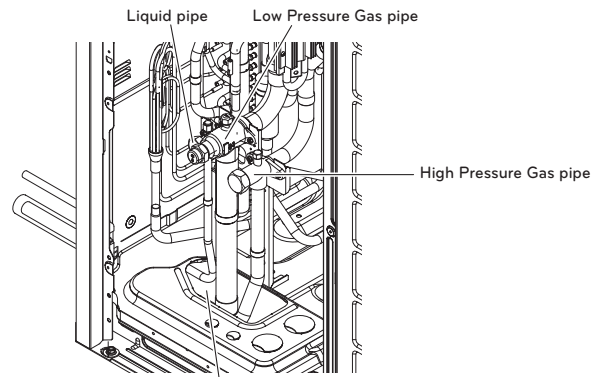

Remove Knock Out for the bottom side of Liquid / Gas pipe

Refrigerant piping system

4 Outdoor Units

Example : 12 Indoor Units connected

- Ⓐ : Outdoor Unit
- Ⓑ : Y branch
- Ⓓ : Indoor Unit
- Ⓔ : Connection branch pipe between Outdoor units : ARCNB41
- Ⓕ : Connection branch pipe between Outdoor units : ARCNB31
- Ⓖ : Connection branch pipe between Outdoor units : ARCNB21
- Ⓗ : Header
- Ⓛ : HR Unit

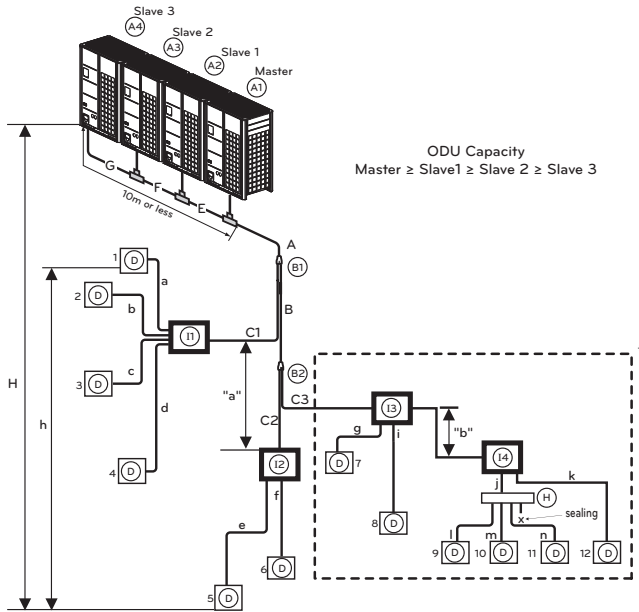

- Case 1 ("a") : Maximum height is 15 m (49.2 ft) if you install with Y branch.
- Case 2 ("b") : Maximum height is 5 m (16.4 ft) in serial connection of HR units.

(**) Conditional Application (In case of D12 is the farthest in door)

Below condition must be satisfied for 40~90 m (131~295 ft) piping length after first branch.

- 1 Diameter of pipes between first branch and the last branch should be increased by one step, except if the pipe diameter B, C3 is same as diameter A (main pipe diameter)
 $\varnothing 6.35$ (1/4), $\varnothing 9.52$ (3/8), $\varnothing 12.7$ (1/2), $\varnothing 15.88$ (5/8), $\varnothing 19.05$ (3/4), $\varnothing 22.2$ (7/8), $\varnothing 25.4^*$ (1), $\varnothing 28.58$ (1-1/8), $\varnothing 31.8^*$ (1-1/4), $\varnothing 34.9$ (1-3/8), $\varnothing 38.1^*$ (1-1/2)
 * : If available on site, select this pipe size.
 Otherwise it doesn't need to be increased
- 2 While calculating total refrigerant piping length, pipe B, C3 length should be calculated twice.
 $A + B \times 2 + C3 \times 2 + C1 + C2 + a + b + c + d + e + f + g + i + j + k + l + m + n \leq 1\,000\text{ m}$ (3281 ft)
- 3 Length of pipe from each indoor unit to the closest HR unit
 $(a, b, c, d, e, f, g, i, j, k, l, m, n) \leq 40\text{ m}$ (131 ft)
- 4 [Length of pipe from outdoor unit to the farthest indoor unit D12 (B+C3+K)
 - [Length of pipe from outdoor unit to the closest indoor unit D1 (C1+a)]
 $\leq 40\text{ m}$ (131 ft)

Refrigerant pipe diameter from branch to branch (B,C,D)

! WARNING

- * : Serial connection of HR units : Capacity sum of indoor units ≤ 192.4 kBtu/hr
- Refer to the HR unit PCB part for the valve group control setting.
- It is recommended that difference in pipe lengths between an HR unit and indoor units, for example difference in length of a, b, c, and d, be minimized. The larger difference in pipe lengths, the more different performance between indoor units.
- Piping length from outdoor branch to outdoor unit $\leq 10\text{m}$ (33ft), equivalent length : max 13m (43ft)
- * If the large capacity indoor units (Over 5 HP; using over $\varnothing 15.88$ (5/8) / $\varnothing 9.52$ (3/8)), are installed, it should be used the Valve Group setting

Refrigerant pipe diameter from branch to branch (B,C)

Downward indoor unit total capacity [kW(Btu/h)]	Liquid pipe [mm(inch)]	Gas pipe [mm(inch)]	
		Low pressure	High pressure
≤ 5.6 (19,100)	$\varnothing 6.35$ (1/4)	$\varnothing 12.7$ (1/2)	$\varnothing 9.52$ (3/8)
< 16.0 (54,600)	$\varnothing 9.52$ (3/8)	$\varnothing 15.88$ (5/8)	$\varnothing 12.7$ (1/2)
< 22.4 (76,400)	$\varnothing 9.52$ (3/8)	$\varnothing 19.05$ (3/4)	$\varnothing 15.88$ (5/8)
< 33.6 (114,700)	$\varnothing 9.52$ (3/8)	$\varnothing 22.2$ (7/8)	$\varnothing 19.05$ (3/4)
< 50.4 (229,000)	$\varnothing 12.7$ (1/2)	$\varnothing 28.58$ (1 1/8)	$\varnothing 22.2$ (7/8)
< 61.6 (210,600)	$\varnothing 15.88$ (5/8)	$\varnothing 28.58$ (1 1/8)	$\varnothing 22.2$ (7/8)
< 72.8 (210,600)	$\varnothing 15.88$ (5/8)	$\varnothing 34.9$ (1 3/8)	$\varnothing 28.58$ (1 1/8)
< 100.8 (344,000)	$\varnothing 19.05$ (3/4)	$\varnothing 34.9$ (1 3/8)	$\varnothing 28.58$ (1 1/8)
< 173.6 (592,500)	$\varnothing 19.05$ (3/4)	$\varnothing 41.3$ (1 5/8)	$\varnothing 34.9$ (1 3/8)
< 184.8 (630,700)	$\varnothing 22.2$ (7/8)	$\varnothing 44.5$ (1 3/4)	$\varnothing 41.3$ (1 5/8)
≤ 224.0 (764,400)	$\varnothing 22.2$ (7/8)	$\varnothing 53.98$ (2 1/8)	$\varnothing 44.5$ (1 3/4)

Total pipe length = A + B + C1 + C2 + C3 + a + b + c + d + e + f + g + i + j + k + l + m + n $\leq 1,000\text{m}$ (3,280ft)

L	Longest pipe length	* Equivalent pipe length
	$A+B+C3+D+k \leq 150\text{m}$ (200m**) [(492ft(656ft**))]	$A+B+C3+D+k \leq 175\text{m}$ (225m**) [(574ft(738ft**))]
l	Longest pipe length after 1st branch	$B+C3+D+k \leq 40\text{m}$ (90m**) [131ft (295ft)]
H	Difference in height(Outdoor Unit ↔ Indoor Unit)	$H \leq 110\text{m}$ (361 ft)
h	Difference in height (Indoor Unit ↔ Indoor Unit)	$h \leq 40\text{m}$ (131 ft)
h1	Difference in height (Outdoor Unit ↔ Outdoor Unit)	$h1 \leq 5\text{m}$ (16.4 ft)
"a", "b"	Difference in height(HR unit ↔ HR unit)	$a \leq 15\text{m}$ (49ft), $b \leq 5\text{m}$ (16ft)

- * : Assume equivalent pipe length of Y branch to be 0.5m (1.64ft), that of header to be 1m (3.3ft), calculation purpose
- It is recommended that indoor unit is installed at lower position than the header.
- ** : To apply conditional application.

! WARNING

When the equivalent length between a outdoor and the farthest indoor unit is 90 m (295 ft) or more, main pipe(A) must be increased one grade.

Refrigerant pipe diameter from outdoor unit to first branch. (A)

ODU Capacity (hp)	Standard Pipe Diameter			Pipe diameter when pipe length is ≥ 90m (295ft) or when height differential (ODU↔IDU) is > 50m (164ft)		
	Liquid Pipe mm (inch)	Low pressure gas pipe mm (inch)	High pressure gas pipe mm (inch)	Liquid Pipe mm (inch)	Low pressure gas pipe mm (inch)	High pressure gas pipe mm (inch)
8	Ø 9.52 (3/8)	Ø19.05 (3/4)	Ø15.88 (5/8)	Ø12.7 (1/2)	Not increased	Not increased
10	Ø 9.52 (3/8)	Ø22.2 (7/8)	Ø19.05 (3/4)	Ø12.7 (1/2)	Not increased	Not increased
12	Ø12.7 (1/2)	Ø28.58 (1-1/8)	Ø19.05 (3/4)	Ø15.88 (5/8)	Not increased	Not increased
14~16	Ø12.7 (1/2)	Ø28.58 (1-1/8)	Ø22.2 (7/8)	Ø15.88 (5/8)	Not increased	Not increased
18~20	Ø15.88 (5/8)	Ø28.58 (1-1/8)	Ø22.2 (7/8)	Ø19.05 (3/4)	Not increased	Not increased
22	Ø15.88 (5/8)	Ø28.58 (1-1/8)	Ø28.58 (1-1/8)	Ø19.05 (3/4)	Not increased	Not increased
24	Ø15.88 (5/8)	Ø34.9 (1-3/8)	Ø28.58 (1-1/8)	Ø19.05 (3/4)	Not increased	Not increased
26~34	Ø19.05 (3/4)	Ø34.9 (1-3/8)	Ø28.58 (1-1/8)	Ø22.2 (7/8)	Not increased	Not increased
36	Ø19.05 (3/4)	Ø41.3 (1-5/8)	Ø28.58 (1-1/8)	Ø22.2 (7/8)	Not increased	Not increased
38~60	Ø19.05 (3/4)	Ø41.3 (1-5/8)	Ø34.9 (1-3/8)	Ø22.2 (7/8)	Not increased	Not increased
62~64	Ø22.2 (7/8)	Ø44.5 (1-3/4)	Ø41.3 (1-5/8)	Ø25.4 (1)	Not increased	Not increased
66~96	Ø22.2 (7/8)	Ø53.98 (2-1/8)	Ø44.5 (1-3/4)	Ø25.4 (1)	Not increased	Not increased

* If available on site, select pipe size according to upper table. Otherwise it doesn't need to be increased

Y branch, Header and HR unit connection pattern

Pattern 1

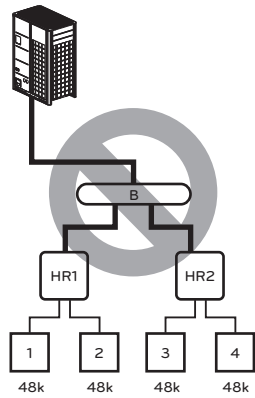

• Impossible installation : Head branch pipe → HR unit

Pattern 2

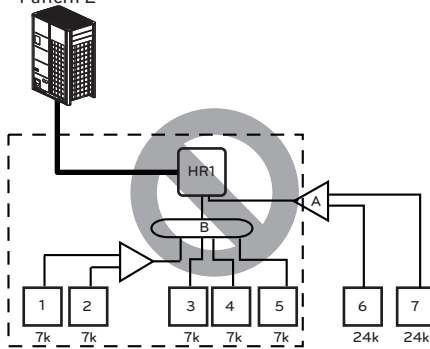

• Impossible installation : HR unit → Head branch pipe → Y and Head branch pipe.

Pattern 3

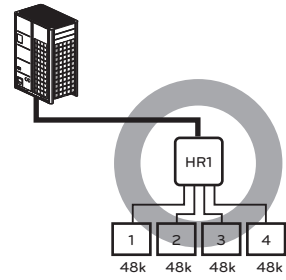

• The maximum total capacity of indoor units is 56.4kW(192 kBtu/h).

Pattern 4

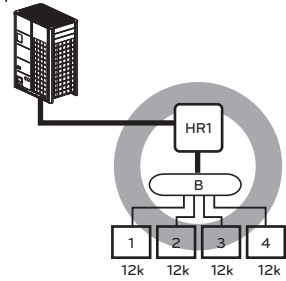

• The maximum total capacity of a branch pipe of HR unit is 14.1kW(48 kBtu/h).

Pattern 5

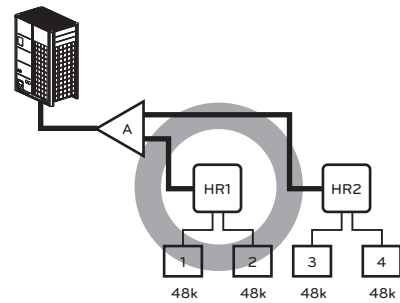

Pattern 6

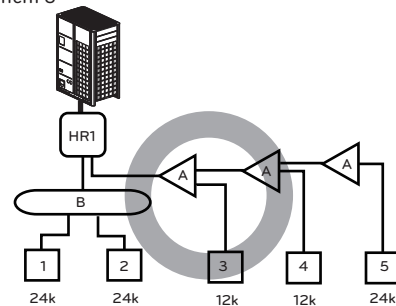

Pattern 7

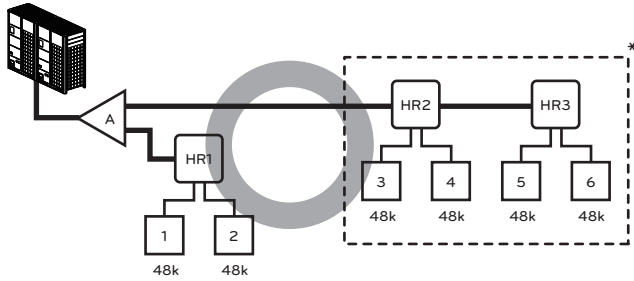

* : Serial connection of HR units : Capacity sum of indoor units ≤ 56.4 kW (192 kBtu/h)

Pattern 8

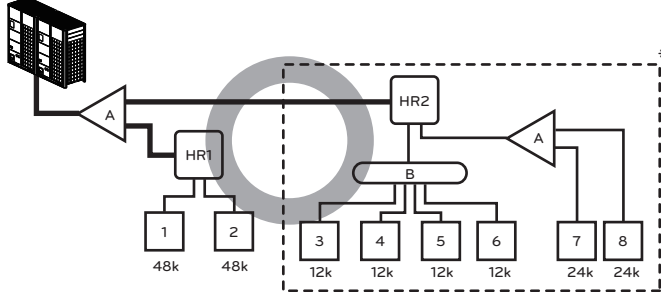

* : Maximum indoor units per a branch are 8 indoor units

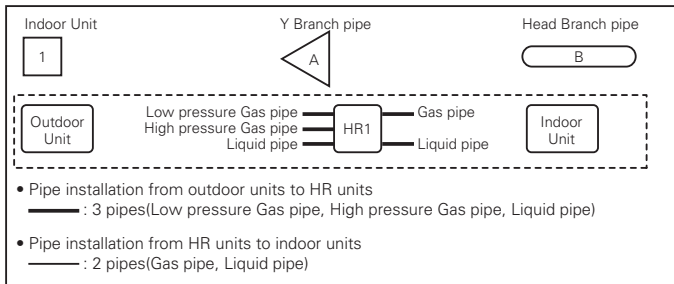

Keep the 40 m (131 ft) distance from the first branch to the farthest indoor.

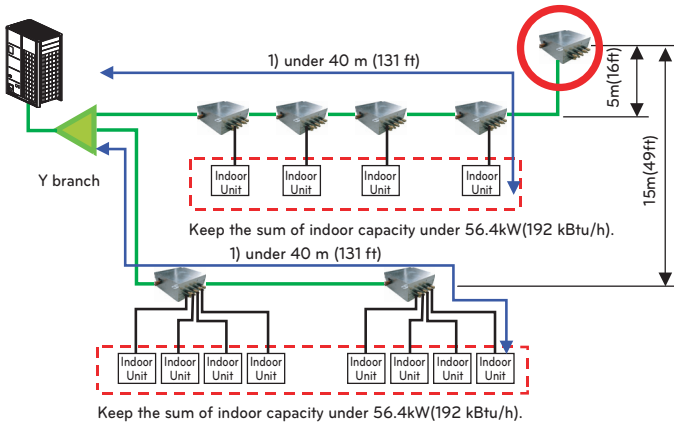

For Heat Pump And Heat Recovery System Installation

Pipe Connection Method between outdoor unit/indoor unit

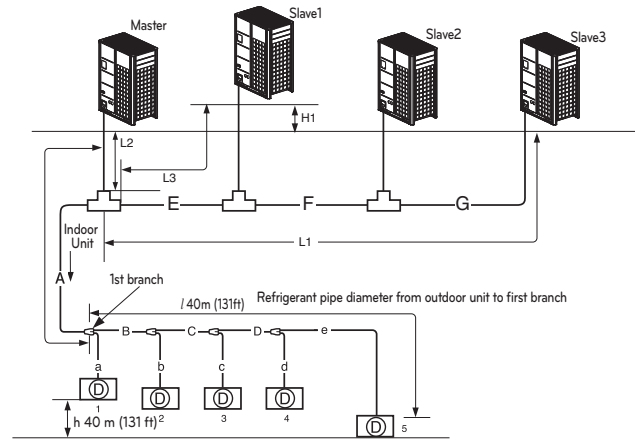

* See Table 2

A : Refrigerant pipe diameter from outdoor unit to first branch

E : Refrigerant pipe diameter for outdoor unit capacity (Slave 1 + Slave 2 + Slave 3)

F : Refrigerant pipe diameter for outdoor unit capacity (Slave 2 + Slave 3)

G : Refrigerant pipe diameter for outdoor unit capacity(Slave 3)

! WARNING

- Branch pipe can not be used after header.
- It is recommended that difference in length of the pipes connected to the indoor units (a~f) is minimized. Performance difference between indoor units may occur.

Level Difference (Outdoor unit ↔ Outdoor unit)	5 m [16.4 ft]
Max length from first branch to each outdoor unit (L1, L2, L3)	Less than 10 m [32.8 ft] (equivalent length of piping 13 m [42.7 ft])

(Table 1) Limit Pipe length

Max pipe length	Outdoor Unit ↔ Indoor Unit	Longest pipe length(L)	Y branch Method	Combination of Y branch/header Method	Header Method
			Equivalent pipe length	A+B+C+D+e ≤ 150 m [492 ft] (200 m [656 ft] : Conditional application)*	A+B+b ≤ 150 m [492 ft] A+C+e ≤ 150 m [492 ft] (200 m [656 ft] : Conditional application)*
Max difference in height	Outdoor Unit ↔ Indoor Unit	Difference in height(H)	110 m [361 ft]	110 m [361 ft]	110 m [361 ft]
	Indoor Unit ↔ Indoor Unit	Difference in height(h)	40 m [131 ft]	40 m [131 ft]	40 m [131 ft]
Longest pipe length after 1st branch		Pipe length(ℓ)	40 m [131 ft] (90 m [295 ft] : Conditional application)*	40 m [131 ft] (90 m [295 ft] : Conditional application)*	40 m [131 ft]

* : See Table 4

! WARNING

- Increased Pipe Diameter(table 2)
- When pipe length is 90m [295 ft] or more from ODU to 1st branch
 - When level difference is 50 m [164 ft] or more

(Table 2) Refrigerant pipe diameter from outdoor unit to first branch. (A)

ODU capacity (hp)	Pipe diameter when pipe length is < 90m (295ft) (Standard)		Pipe diameter when pipe length is ≥ 90m (295ft)		Pipe diameter when height differential (ODU→IDU) is > 50m (164ft)	
	Liquid Pipe mm (inch)	Gas Pipe mm (inch)	Liquid Pipe mm (inch)	Gas Pipe mm (inch)	Liquid Pipe mm (inch)	Gas Pipe mm (inch)
8	Ø9.52 (3/8)	Ø19.05 (3/4)	Ø12.7 (1/2)	Ø22.2 (7/8)	Ø12.7 (1/2)	Not increased
10	Ø9.52 (3/8)	Ø22.2 (7/8)	Ø12.7 (1/2)	Ø28.58 (1-1/8)	Ø12.7 (1/2)	Not increased
12~16	Ø12.7 (1/2)	Ø28.58 (1-1/8)	Ø15.88 (5/8)	Ø34.9 (1-3/8)	Ø15.88 (5/8)	Not increased
18~22	Ø15.88 (5/8)	Ø28.58 (1-1/8)	Ø19.05 (3/4)	Ø34.9 (1-3/8)	Ø19.05 (3/4)	Not increased
24	Ø15.88 (5/8)	Ø34.9 (1-3/8)	Ø19.05 (3/4)	Ø41.3 (1-5/8)	Ø19.05 (3/4)	Not increased
26~34	Ø19.05 (3/4)	Ø34.9 (1-3/8)	Ø22.2 (7/8)	Ø41.3 (1-5/8)	Ø22.2 (7/8)	Not increased
36~60	Ø19.05 (3/4)	Ø41.3 (1-5/8)	Ø22.2 (7/8)	Ø44.5 (1-3/4)	Ø22.2 (7/8)	Not increased
62~64	Ø22.2 (7/8)	Ø44.5 (1-3/4)	Ø25.4 (1)	Ø53.98 (2-1/8)	Ø25.4 (1)	Not increased
66~96	Ø22.2 (7/8)	Ø53.98 (2-1/8)	Ø25.4 (1)	Ø53.98 (2-1/8)	Ø25.4 (1)	Not increased

(Table 3) Refrigerant pipe diameter from first branch to last branch (B,C,D)

Downward indoor unit total capacity [kW(Btu/h)]	Liquid pipe [mm(inch)]	Gas pipe [mm(inch)]
≤ 5.6(19,100)	Ø6.35(1/4)	Ø12.7(1/2)
< 16.0 (54,600)	Ø9.52(3/8)	Ø15.88(5/8)
≤ 22.4 (76,400)	Ø9.52(3/8)	Ø19.05(3/4)
< 33.6 (114,700)	Ø9.52(3/8)	Ø22.2(7/8)
< 50.4 (172,000)	Ø12.7(1/2)	Ø28.58(1-1/8)
< 67.2 (229,400)	Ø15.88(5/8)	Ø28.58(1-1/8)
< 72.8(248,500)	Ø15.88(5/8)	Ø34.9(1-3/8)
< 100.8(344,000)	Ø19.05(3/4)	Ø34.9(1-3/8)
< 173.6(592,500)	Ø19.05(3/4)	Ø41.3(1-5/8)
< 184.8(630,700)	Ø22.2(7/8)	Ø44.5(1-3/4)
≤ 224.0(764,400)	Ø22.2(7/8)	Ø53.98(2-1/8)

(Table 4) Conditional Application

- To satisfy below condition to make 40 m ~ 90 m of pipe length after first branch.

	Condition	Example	
1	Diameter of pipes between first branch and the last branch should be increased by one step, except pipe diameter B,C,D is same as Diameter A	40 m [131 ft] < B+C+D+e 90 m [295 ft] → B, C, D Change a diameter	Ø6.35(1/4) → Ø9.52(3/8), Ø9.52(3/8) → Ø12.7(1/2), Ø12.7(1/2) → Ø15.88(5/8), Ø15.88(5/8) → Ø19.05(3/4), Ø19.05(3/4) → Ø22.2(7/8), Ø22.2(7/8) → Ø25.4(1), Ø25.4(1) → Ø28.58(1-1/8), Ø28.58(1-1/8) → Ø31.8(1-1/4), Ø31.8(1-1/4) → Ø34.9(1-3/8), Ø34.9(1-3/8) → Ø38.1(1-1/2)
2	While calculating whole refrigerant pipe length, pipe B,C,D length should be calculated twice.	A+Bx2+Cx2+Dx2 +a+b+c+d+e ≤ 1 000 m [3 281 ft]	
3	Length of pipe from each indoor unit to the closest branch	a,b,c,d,e ≤ 40 m [131 ft]	
4	Length of pipe from outdoor unit to the farthest indoor unit 5 (A+B+C+D+e) - [Length of pipe outdoor unit to the closest indoor unit 1 (A+a)] ≤ 40 m [131 ft]	(A+B+C+D+e) - (A+a) ≤ 40 m [131 ft]	

WARNING

- In case of pipe diameter B connected after first branch is bigger than the main pipe diameter A, B should be of the same size with A.

Ex) In case indoor unit combination ratio 120% is connected to 24HP(67.2 kW) outdoor unit.
 1) Outdoor unit main pipe diameter A : Ø34.9(1-3/8)(Gas pipe), Ø15.88(5/8)(liquid pipe)
 2) Pipe diameter B after first branch according to 120% indoor unit combination(80.6kW) : Ø34.9(1-3/8)(gas pipe), Ø19.05(3/4)(liquid pipe)
 Therefore, pipe diameter B connected after first branch would be Ø34.9(1-3/8)(gas pipe) / Ø15.88(5/8)(liquid pipe) which is same with main pipe diameter.

Outdoor unit Connection

WARNING

- In case of pipe diameter B connected after first branch is bigger than the main pipe diameter A, B should be of the same size with A.

Ex) In case indoor unit combination ratio 120% is connected to 70kW outdoor unit.
 1) Outdoor unit main pipe diameter A : Ø34.9(1-3/8)(Low pressure gas pipe), Ø15.88(5/8)(liquid pipe), Ø28.58(1-1/8)(High Pressure liquid pipe)
 2) Pipe diameter B after first branch according to 120% indoor unit combination(84kW) : Ø34.9(1-3/8)(Low pressure gas pipe), Ø19.05(3/4)(liquid pipe), Ø28.58(1-1/8)(High Pressure liquid pipe)
 Therefore, pipe diameter B connected after first branch would be Ø34.9(1-3/8)(Low pressure gas pipe), Ø15.88(5/8)(liquid pipe), Ø28.58(1-1/8)(High Pressure liquid pipe) which is same with main pipe diameter.

[Example]

Do not choose the main pipe diameter by downward indoor unit total capacity but its outdoor unit model name.
 Do not let the connection pipe from branch to branch exceed the main pipe diameter chosen by outdoor unit model name.
 EX) Where connecting the indoor units to the 22 HP (61.5 kW) outdoor unit to 120% of its system capacity (73.8 kW) and branching 7k (2.1kW) indoor unit at the 1st branch
 Main pipe diameter(22 HP outdoor unit): Ø28.58(1-1/8)(Low pressure gas pipe), Ø15.88(5/8)(Liquid pipe), Ø22.2(7/8)(High pressure gas pipe)

Pipe diameter between 1st and 2nd branch (71.7kW indoor units): Ø34.9(1-3/8)(Gas pipe) Ø19.05(3/4)(Liquid pipe) in conformity with Downward indoor units.

Since the main pipe diameter of 22HP outdoor unit is Ø28.58(1-1/8)(Low pressure gas pipe), Ø15.88(5/8)(Liquid pipe), Ø22.2(7/8) (High pressure gas pipe) is used as the main pipe and the connection pipe between 1st and 2nd branch.

Indoor Unit Connection

Indoor Unit connecting pipe from branch (a,b,c,d,e,f)

Indoor Unit capacity [kW(Btu/h)]	Liquid pipe [mm(inch)]	Gas pipe [mm(inch)]
≤ 5.6(19,100)	Ø6.35(1/4)	Ø12.7(1/2)
< 16.0(54,600)	Ø9.52(3/8)	Ø15.88(5/8)
< 22.4(76,400)	Ø9.52(3/8)	Ø19.05(3/4)
< 28.0(95,900)	Ø9.52(3/8)	Ø22.2(7/8)

CAUTION

- Bending radius should be at least twice the diameter of the pipe.
- Bend pipe after 500mm [19.7 inch] or more from branch(or header). Do not bend U type. It may affect performance or result in noise. If U type bending is required the R should be more than 200mm [7.9 inch]

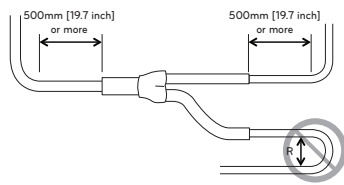

Examples of Wrong Pipe Connections

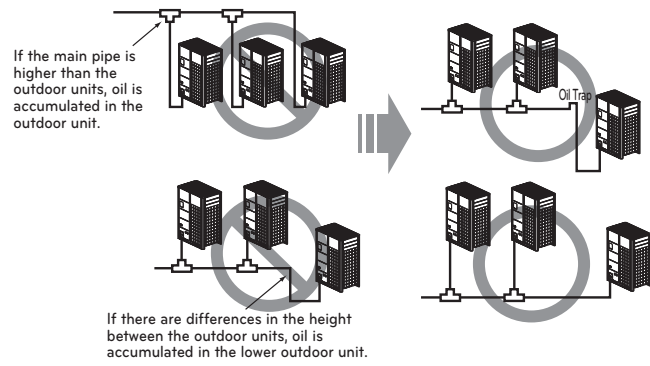

Pipe Connection Method/Precautions for Series connections between Outdoor units

- Separate Y branch joints are needed for series connections between outdoor units.
- Please refer to the below connection examples to install pipe connections between outdoor units.

Pipe connection between outdoor units (General Case)

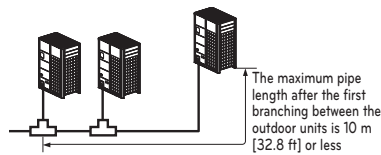

Pipes between outdoor units are 2 m [6.6 ft] or less

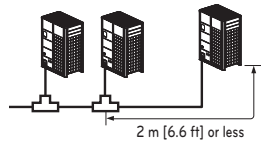

Pipes between outdoor units are 2 m [6.6 ft] or longer

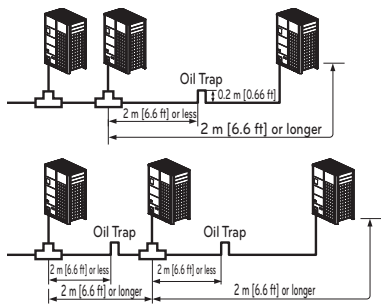

- If the distance between the outdoor units becomes more than 2 m [6.6 ft], apply Oil Traps between the gas pipes.
- If the outdoor unit is located lower than the main pipe, apply Oil Trap.

(Example 1)

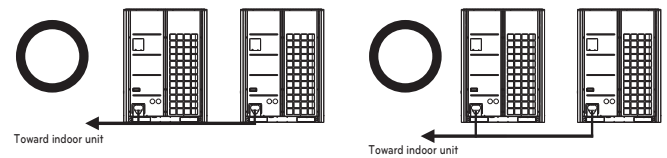

(Example 2)

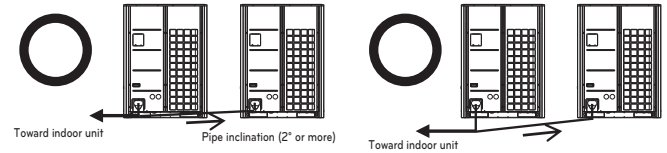

(Example 3)

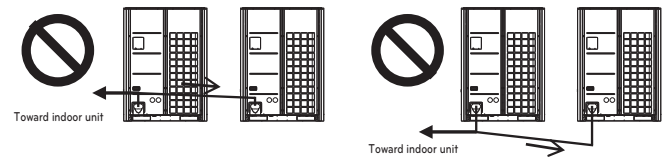

- Apply Oil Trap as shown below when the length of the pipe between the outdoor units is more than 2 m [6.6 ft]. Otherwise, the unit may not operate properly.

(Example 1)

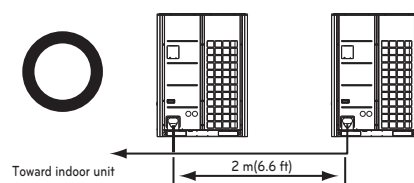

(Example 2)

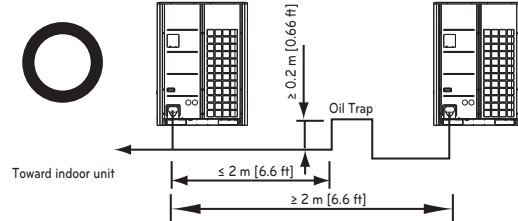

- When connecting the pipes between the outdoor units, the accumulation of oil in the slave outdoor unit should be avoided. Otherwise, the unit may not operate properly.

(Example 1)

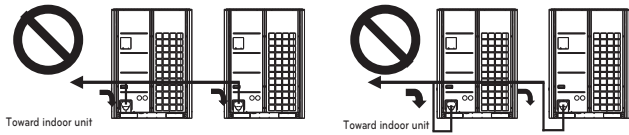

(Example 2)

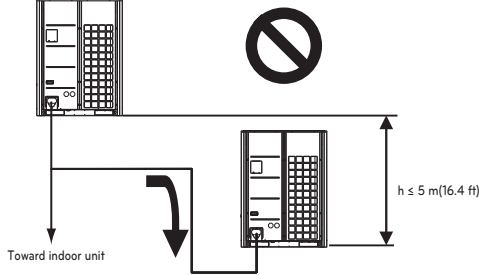

(Example 3)

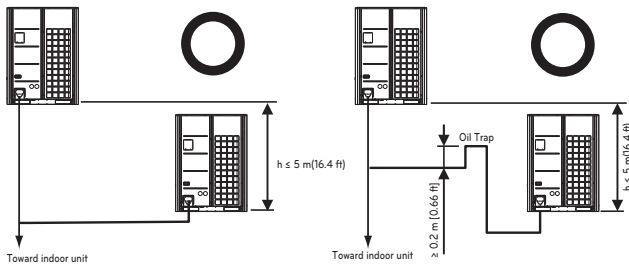

Branch pipe Fitting

Y branch

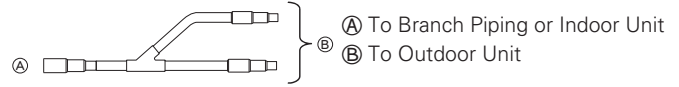

- Ensure that the branch pipes are attached horizontally or vertically (see the diagram below.)

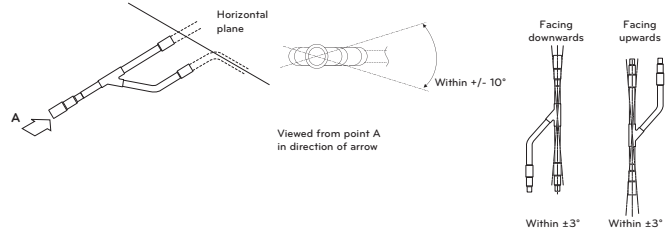

- There is no limitation on the joint mounting configuration.
- If the diameter of the refrigerant piping selected by the procedures described is different from the size of the joint, the connecting section should be cut with a pipe cutter.
- Branch pipe should be insulated with the insulator in each kit.

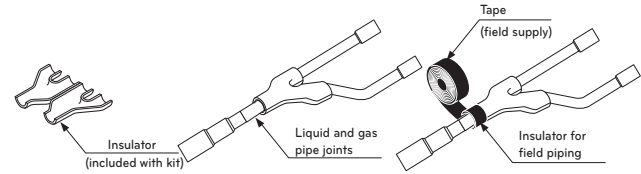

Header

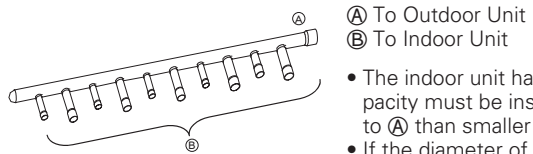

- The indoor unit having larger capacity must be installed closer to A than smaller one.
- If the diameter of the refrigerant piping selected by the procedures described is different from the size of the joint, the connecting section should be cut with a pipe cutter.

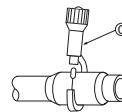

© Pipe cutter

- When the number of pipes to be connected is smaller than the number of header branches, install a cap to the unconnected branches.

- When the number of indoor units to be connected to the branch pipes is less than the number of branch pipes available for connection then cap pipes should be fitted to the surplus branches.

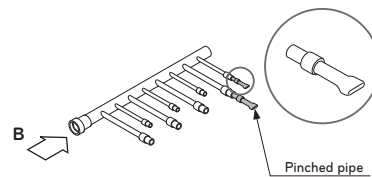

- Fit branch pipe lie in a horizontal plane.

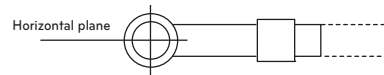

View from point B in the direction of the arrow

- Header should be insulated with the insulator in each kit.

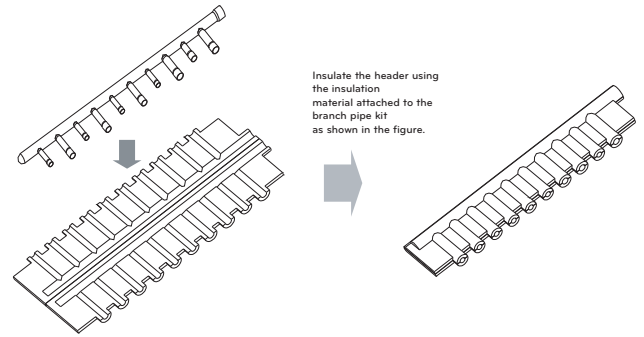

- Joints between branch and pipe should be sealed with the tape included in each kit.

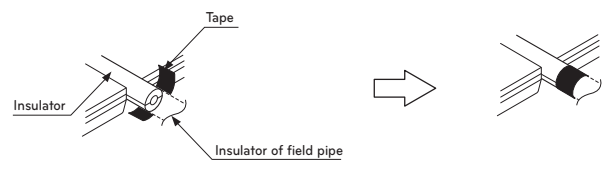

- Any cap pipe should be insulated using the insulator provided with each kit and then taped as described above.

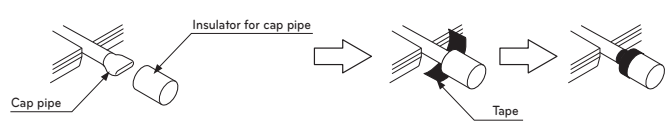

Y branch pipe

[Unit:mm(inch)]

Models	Gas pipe	Liquid pipe
ARBLN01621		
ARBLN03321		
ARBLN07121		
ARBLN14521		
ARBLN23220		

Header

[Unit:mm(inch)]

Models	Gas pipe	Liquid pipe
4 branch ARBL054		
7 branch ARBL057		
4 branch ARBL104		
7 branch ARBL107		
10 branch ARBL1010		
10 branch ARBL2010		

Distribution Method

Horizontal Distribution

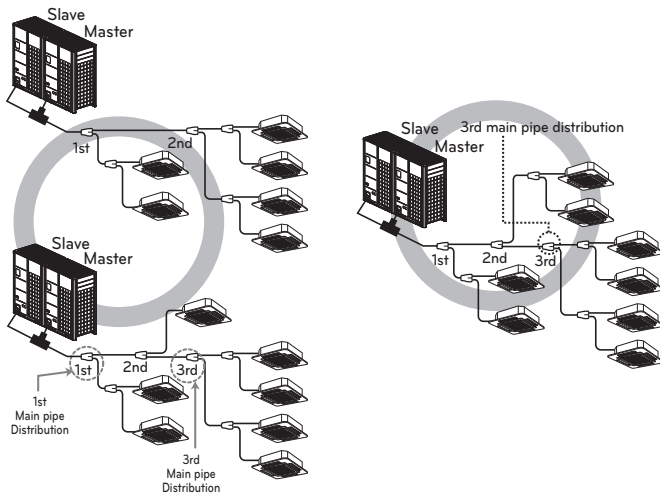

Vertical Distribution

- Ensure that the branch pipes are attached vertically.

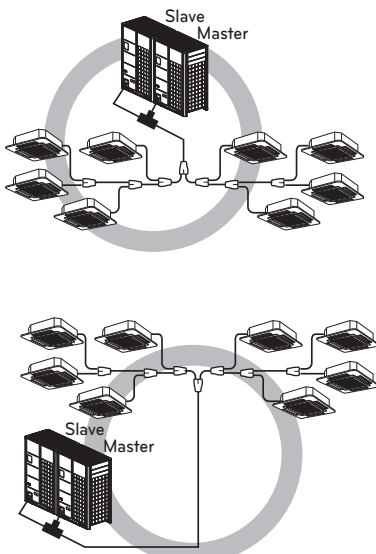

The others

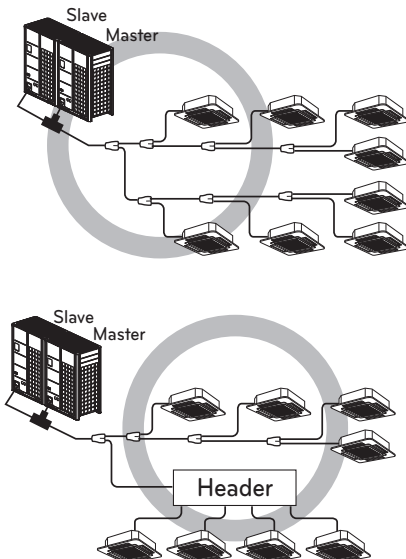

Vacuum Mode

This function is used for creating vacuum in the system after compressor replacement, ODU parts replacement or IDU addition/replacement.

Vacuum mode setting method

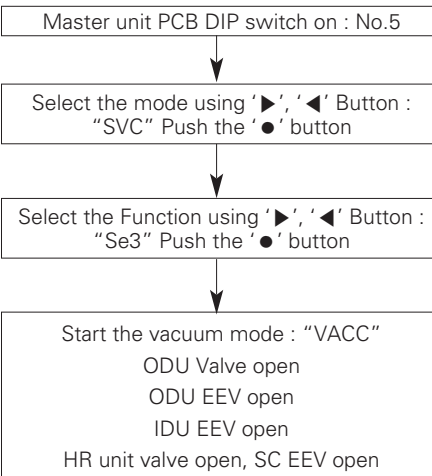
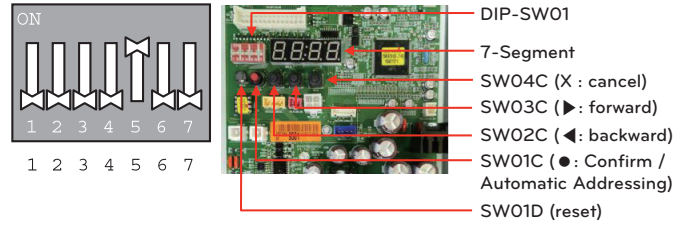

Vacuum mode off method



CAUTION

ODU operation stops during vacuum mode. Compressor can't operate.

Leak Test and Vacuum drying

Leak test

Leak test should be made by pressurizing nitrogen gas to 3.8 MPa(38.7kgf/cm²). If the pressure does not drop for 24 hours, the system passes the test. If the pressure drops, check where the nitrogen leaks. For the test method, refer to the following figure. (Make a test with the service valves closed. Be also sure to pressurize liquid pipe, gas pipe and high pressure gas pipe)

The test result can be judged good if the pressure has not be reduced after leaving for about one day after completion of nitrogen gas pressurization.

Series Installation (Heat Pump)

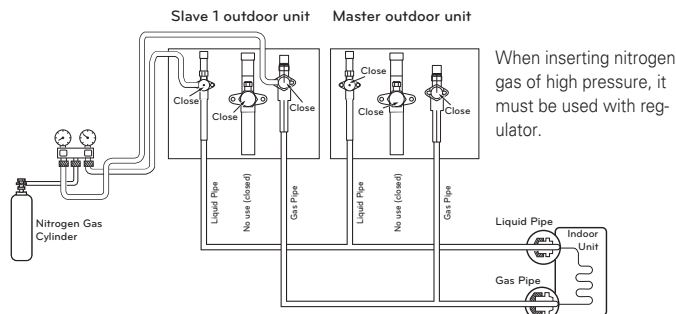

Series Installation (Heat Recovery)

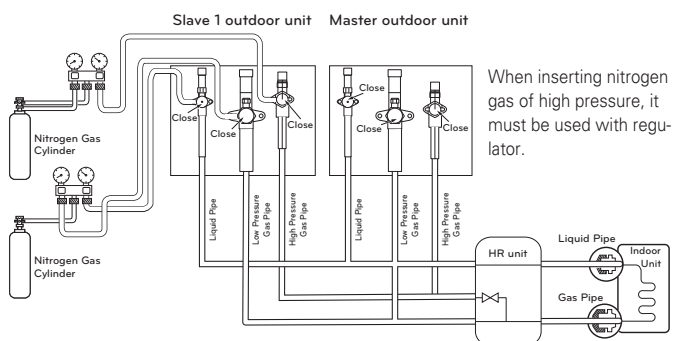

WARNING

Use a vacuum pump or Inert(nitrogen) gas when doing leakage test or air purge. Do not compress air or Oxygen and do not use Flammable gases. Otherwise, it may cause fire or explosion.

- There is the risk of death, injury, fire or explosion.

NOTE

If the ambient temperature differs between the time when pressure is applied and when the pressure drop is checked, apply the following correction factor

There is a pressure change of approximately 0.01Mpa(1.5psi) for each 33.8°F (1°C) of temperature difference.

Correction= (Temp. at the time of pressurization – Temp. at the time of check) X 0.1

For example: Temperature at the time of pressurization 3.8MPa(551psi) is 80.6°F (27°C)
24 hour later: 3.73MPa(541psi), 68°F (20°C)
In this case the pressure drop of 0.07MPa (10psi) is because of temperature drop
And hence there is no leakage in pipe occurred.

CAUTION

To prevent the nitrogen from entering the refrigeration system in the liquid state, the top of the cylinder must be at higher position than the bottom when you pressurize the system.

Usually the cylinder is used in a vertical standing position.

Vacuum

Vacuum drying should be made from the service port provided on the outdoor unit's service valve to the vacuum pump commonly used for liquid pipe, gas pipe and high/low pressure common pipe. (Make Vacuum from liquid pipe, gas pipe and high/low pressure common pipe with the service valve closed.)

* Never perform air purging using refrigerant.

- Vacuum drying: Use a vacuum pump that can evacuate to -100.7kPa (-14.6psi, 5 Torr, -755mmHg).

- Evacuate the system from the liquid and gas pipes with a vacuum pump for over 2 hrs and bring the system to -100.7kPa(-14.6psi). After maintaining system under that condition for over 1 hr, confirm the vacuum gauge rises. The system may contain moisture or leak.

- Following should be executed if there is a possibility of moisture remaining inside the pipe. (Rainwater may enter the pipe during work in the rainy season or over a long period of time)

After evacuating the system for 2 hrs, give pressure to the system to 0.05MPa(7.3psi) (vacuum break) with nitrogen gas and then evacuate it again with the vacuum pump for 1hr to -100.7kPa(-14.6psi)(vacuum drying). If the system cannot be evacuated to -100.7kPa(-14.6psi) within 2 hrs, repeat the steps of vacuum break and its drying. Finally, check if the vacuum gauge does not rise or not, after maintaining the system in vacuum for 1 hr.

Series Installation (Heat Pump)

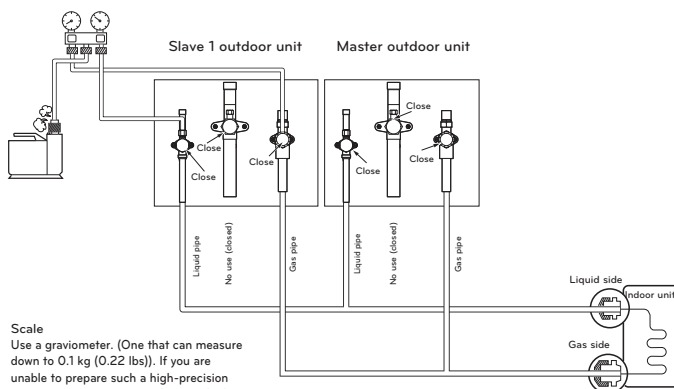

Scale
Use a gravimeter. (One that can measure down to 0.1 kg (0.22 lbs)). If you are unable to prepare such a high-precision gravimeter you may use a charge cylinder.

Series Installation (Heat Recovery)

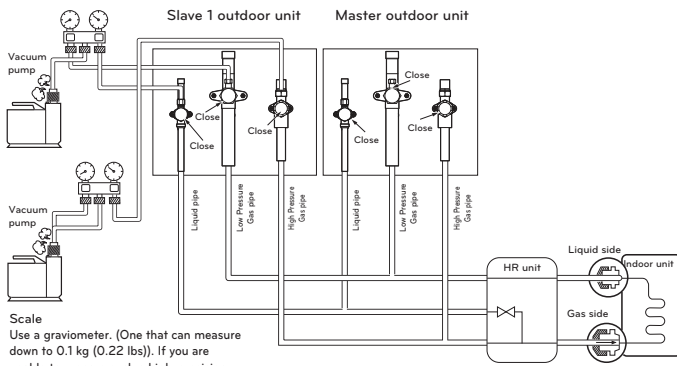

Scale
Use a gravimeter. (One that can measure down to 0.1 kg (0.22 lbs)). If you are unable to prepare such a high-precision gravimeter you may use a charge cylinder.

! WARNING

Use a vacuum pump or Inert(nitrogen) gas when doing leakage test or air purge. Do not compress air or Oxygen and do not use Flammable gases. Otherwise, it may cause fire or explosion.
- There is the risk of death, injury, fire or explosion.

! NOTE

Always add an appropriate amount of refrigerant. (For the refrigerant additional charge)
Too much or too little refrigerant will cause trouble.
To use the Vacuum Mode (If the Vacuum mode is set, all valves of Indoor units and Outdoor units will be opened.)

! WARNING

When installing and moving the air conditioner to another site, recharge after perfect evacuation.
- If a different refrigerant or air is mixed with the original refrigerant, the refrigerant cycle may malfunction and the unit may be damaged.

Refrigerant charging

For Heat Pump System Installation

- Ⓐ Manifold Gauge
- Ⓑ Low Pressure Side Handle
- Ⓒ High Pressure Side Handle

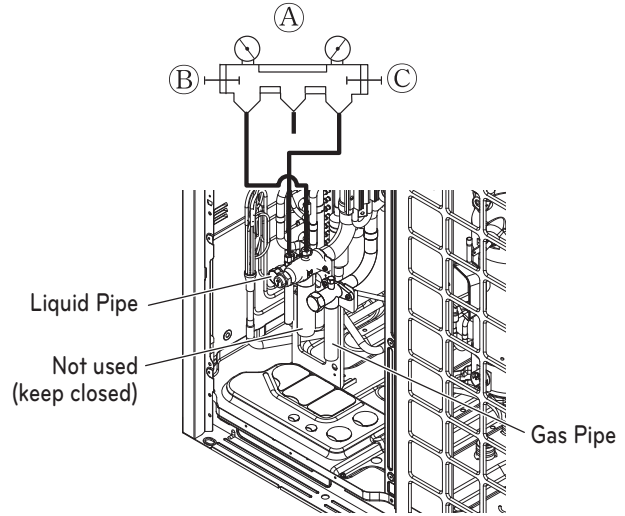

For Heat Recovery System Installation

- Ⓐ Manifold Gauge
- Ⓑ Low pressure side Handle
- Ⓒ High pressure side Handle

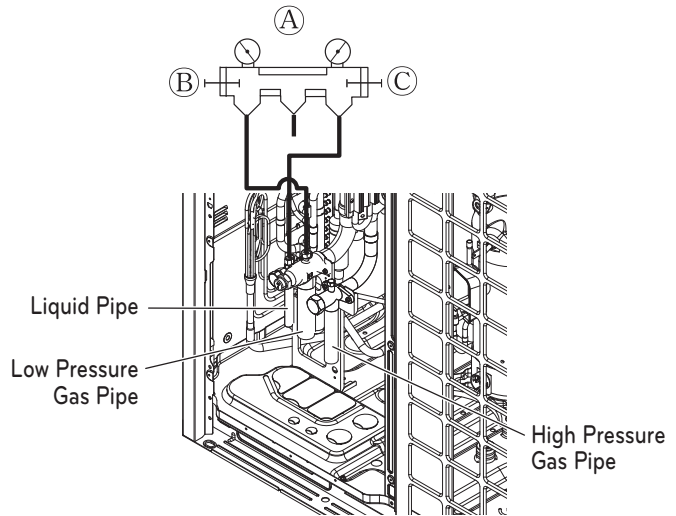

! WARNING

- Pipe to be vacuumed : gas pipe, liquid pipe
(In case of Heat Recovery system, pipe to be vacuumed : High pressure gas pipe, Low pressure gas pipe, Liquid pipe)
- If the refrigerant amount is not exact, it may not operate properly.
- If additionally bottled refrigerant amount is over 10%, condenser burst or insufficient indoor unit performance may be caused.

The amount of Refrigerant

The calculation of the additional charge should take into account the length of pipe and CF(correction Factor) value of indoor unit.

Additional charge(kg)	=	Total liquid pipe : Ø25.4 mm (1.0 inch)	× 0.480 kg/m (0.323 lbs/ft)
	+	Total liquid pipe : Ø22.2 mm (7/8 inch)	× 0.354 kg/m (0.238 lbs/ft)
	+	Total liquid pipe : Ø19.05 mm (3/4 inch)	× 0.266 kg/m (0.179 lbs/ft)
	+	Total liquid pipe : Ø15.88 mm (5/8 inch)	× 0.173 kg/m (0.116 lbs/ft)
	+	Total liquid pipe : Ø12.7 mm (1/2 inch)	× 0.118 kg/m (0.079 lbs/ft)
	+	Total liquid pipe : Ø9.52 mm (3/8 inch)	× 0.061 kg/m (0.041 lbs/ft)
	+	Total liquid pipe : Ø6.35 mm (1/4 inch)	× 0.022 kg/m (0.015 lbs/ft)
	Include only for Heat Recovery system	+	Number of installed HR units
CF value of indoor unit			

Amount refrigerant of Indoor units

Example) 4Way Ceiling Cassette 14.5kW -1ea, Ceiling concealed Duct 7.3kW-2ea, Wall Mounted 2.3kW-4ea
 CF = [0.64 kg (1.411 lbs)×1EA] + [0.26 kg (0.573 lbs)×2EA] + [0.26 kg (0.529 lbs)×4EA]
 = 2.12 kg (4.67 lbs)

Attach the additional refrigerant table of IDU.

WARNING

- Regulation for refrigerant leakage : the amount of refrigerant leakage should satisfy the following equation for human safety.

$$\frac{\text{Total amount of refrigerant in the system}}{\text{Volume of the room at which Indoor Unit of the least capacity is installed}} \leq 0.44 \text{ kg/m}^3 \text{ (0.028 lbs/ft}^3\text{)}$$

If the above equation can not be satisfied, then follow the following steps.

- Selection of air conditioning system: select one of the next
 - Installation of effective opening part
 - Reconfirmation of Outdoor Unit capacity and piping length
 - Reduction of the amount of refrigerant
 - Installation of 2 or more security device (alarm for gas leakage)
- Change Indoor Unit type : installation position should be over 2 m (6.6 ft) from the floor (Wall mounted type → Cassette type)
- Adoption of ventilation system : choose ordinary ventilation system or building ventilation system
- Limitation in piping work : Prepare for earthquake and thermal stress

Thermal insulation of refrigerant piping

Be sure to give insulation work to refrigerant piping by covering liquid pipe and gas pipe separately with enough thickness heat-resistant polyethylene, so that no gap is observed in the joint between indoor unit and insulating material, and insulating materials themselves. When insulation work is insufficient, there is a possibility of condensation drip, etc. Pay special attention to insulation work to ceiling plenum.

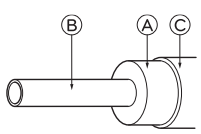

Heat insulation material	Adhesive + Heat - resistant polyethylene foam + Adhesive tape	
	Indoor	Vinyl tape
	Outer covering	Floor exposed
	Outdoor	Water-proof hemp cloth + Zinc plate + Oily paint

- A Heat insulation material
- B Pipe
- C Outer covering(Wind the connection part and cutting part of heat insulation material with a finishing tape.)

NOTE

When using polyethylene cover as covering material, asphalt roofing shall not be required.

Bad example

- Do not insulate gas or low pressure pipe and liquid or high-pressure pipe together.

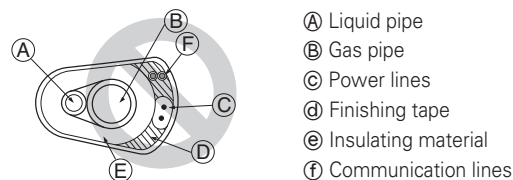

- Be sure to fully insulate connecting portion.

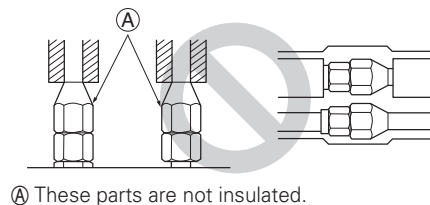

Good example

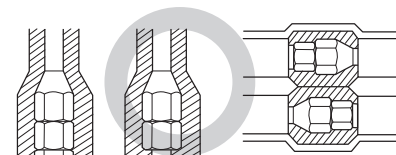
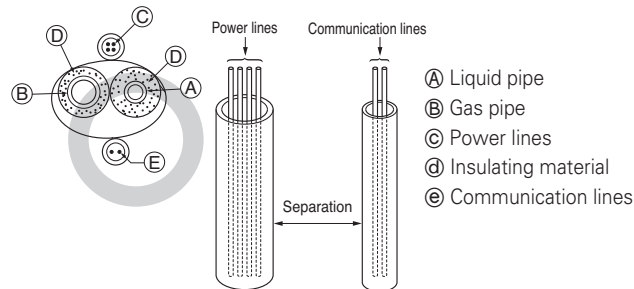

Penetrations

Inner wall (concealed)

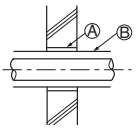

Outer wall

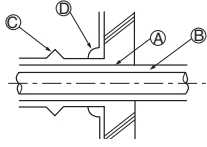

Outer wall (exposed)

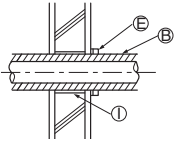

Floor (fireproofing)

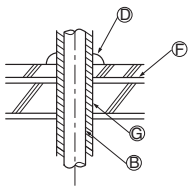

Penetrating portion on fire limit and boundary wall

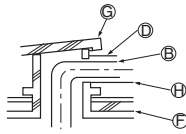

Roof pipe shaft

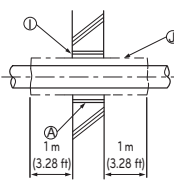

- Ⓐ Sleeve
- Ⓑ Heat insulating material
- Ⓒ Lagging
- Ⓓ Caulking material
- Ⓔ Band
- Ⓕ Waterproofing layer
- Ⓖ Sleeve with edge
- Ⓗ Lagging material
- Ⓘ Mortar or other incombustible caulking
- Ⓢ Incombustible heat insulation material

When filling a gap with mortar, cover the penetration part with steel plate so that the insulation material will not be caved in. For this part, use incombustible materials for both insulation and covering. (Vinyl covering should not be used.)

ELECTRICAL WIRING

Caution

- Follow ordinance of your governmental organization for technical standard related to electrical equipment, wiring regulations and guidance of each electric power company.

! WARNING

Be sure to have authorized electrical engineers do the electric work using special circuits in accordance with regulations and this installation manual. If power supply circuit has a lack of capacity or electric work deficiency, it may cause an electric shock or fire.

- Install the Outdoor Unit communication cable away from the power source wiring so that it is not affected by electric noise from the power source. (Do not run it through the same conduit.)
- Be sure to provide designated grounding work to Outdoor Unit.

! CAUTION

Be sure to correct the outdoor unit to earth. Do not connect ground wire to any gas pipe, liquid pipe, lightning rod or telephone earth line. If earth is incomplete, it may cause an electric shock.

- Give some allowance to wiring for electrical part box of Indoor and Outdoor Units, because the box is sometimes removed at the time of service work.
- Never connect the main power source to terminal block of communication cable. If connected, electrical parts will be burnt out.
- Use the 2-core shielded wires for communication cable. (○ mark in the figure below) If communication cable of different systems are wired with the same multicore cable, the resultant poor transmitting and receiving will cause erroneous operations. (⊗ mark in the figure below)
- Only the communication cable specified should be connected to the terminal block for Outdoor Unit communication.

2-core shielded cables

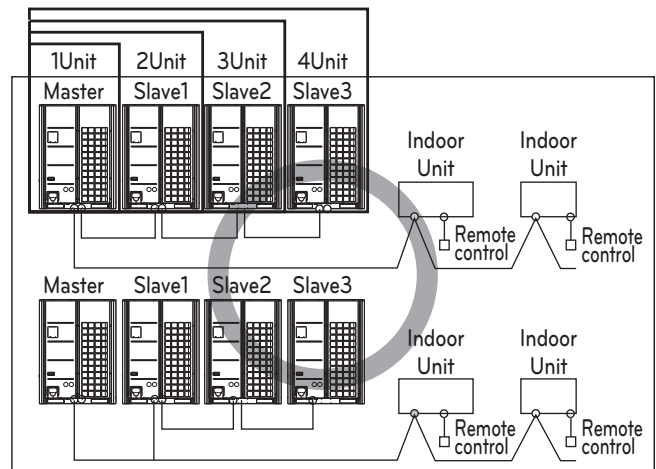

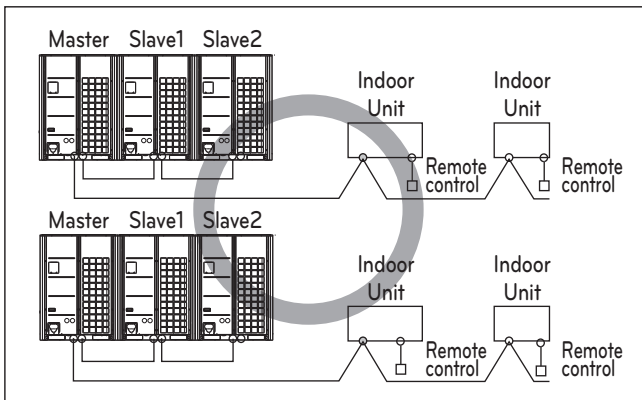
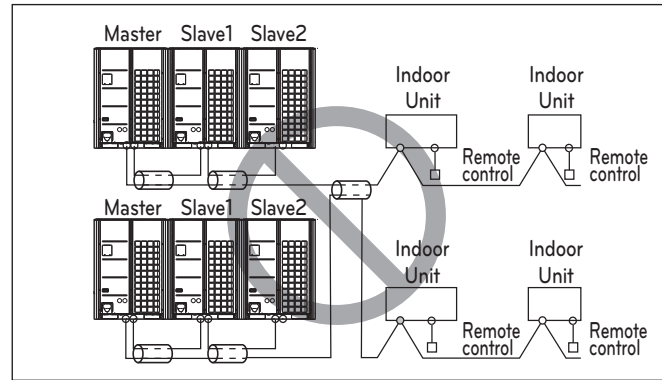
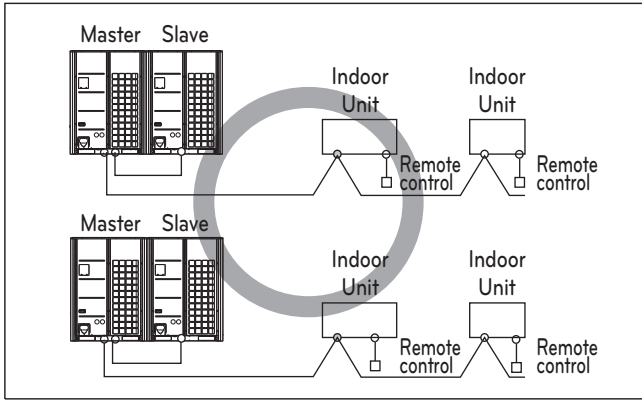

Multi-Core Cable

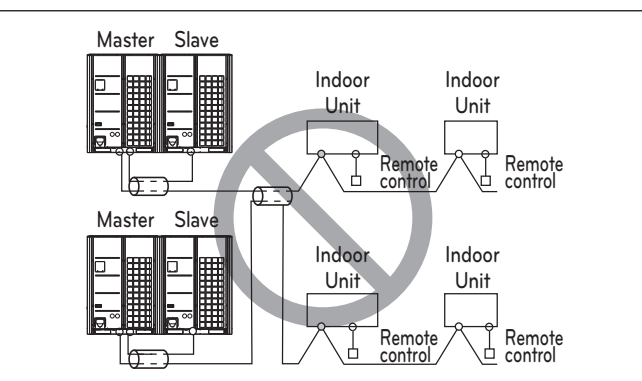
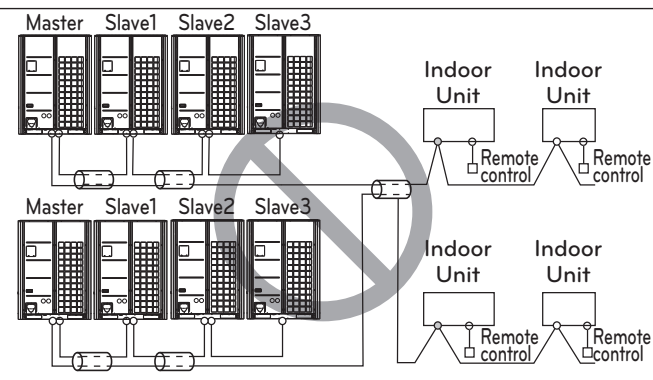

CAUTION

- Use the 2-core shielded wires for communication cables. Never use them together with power cables.
- The conductive shielding layer of cable should be grounded to the metal part of both units.
- Never use multi-core cable
- As this unit is equipped with an inverter, to install a phase leading capacitor not only will deteriorate power factor improvement effect, but also may cause capacitor abnormal heating. Therefore, never install a phase leading capacitor.
- Make sure that the power unbalance ratio is not greater than 2%. If it is greater the units lifespan will be reduced.

Precautions when laying power wiring

Use round pressure terminals for connections to the power terminal block.

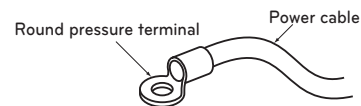

When none are available, follow the instructions below.

- Do not connect wiring of different thicknesses to the power terminal block. (Slack in the power wiring may cause abnormal heat.)
- When connecting cable which is the same thickness, do as shown in the figure below.

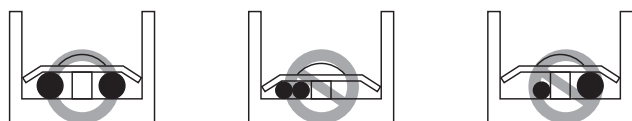

- For wiring, use the designated power cable and connect firmly, then secure to prevent outside pressure being exerted on the terminal block.
- Use an appropriate screwdriver for tightening the terminal screws. A screwdriver with a small head will strip the head and make proper tightening impossible.
- Over-tightening the terminal screws may break them.

CAUTION

When the 400 volt power supply is applied to "N" phase by mistake, check damaged parts in control box and replace them.

Control box and connecting position of wiring

- Remove all of the screws at front panel and remove the panel by pulling it forward.
- Connect communication cable between main and sub outdoor unit through the terminal block.
- Connect communication cables between outdoor unit and indoor units through the terminal block.
- When the central control system is connected to the outdoor unit, a dedicated PCB must be connected between them.
- When connecting communication cable between outdoor unit and indoor units with shielded cable, connect the shield ground to the earth screw.

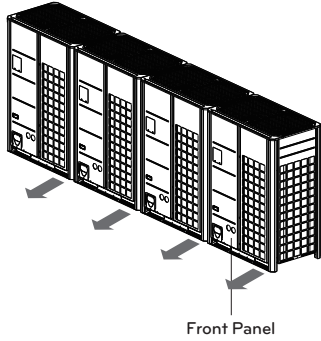

WARNING

The temperature sensor for outdoor air should not be exposed to direct sunlight.
 - Provide an appropriate cover to intercept direct sunlight.

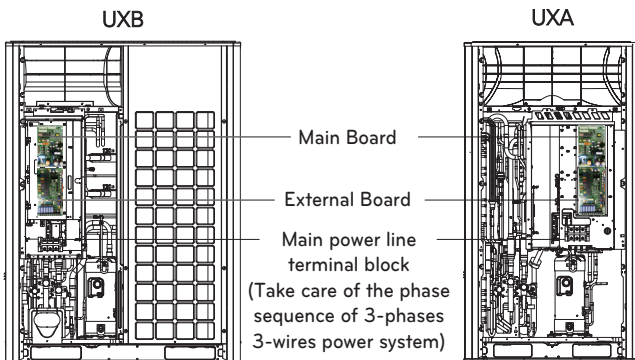

Communication and Power Cables

Communication cable

- Types : shielded wires or unshielded wires
- Cross section : 1.0 ~ 1.5 mm² (1.55 × 10⁻³ ~ 2.32 × 10⁻³ in²)
- Maximum allowable temperature: 60 °C (140 °F)
- Maximum allowable cable length: under 1 000 m (3 281 ft)

Remote control cable

- Types : 3-core cables

Central control cable

Product type	Cable type	Diameter
ACP&AC Manager	2-core wires (shielded)	1.0 ~ 1.5 mm ² (1.55 × 10 ⁻³ ~ 2.32 × 10 ⁻³ in ²)
AC Smart	2-core wires (shielded)	1.0 ~ 1.5 mm ² (1.55 × 10 ⁻³ ~ 2.32 × 10 ⁻³ in ²)
Simple central controller	4-core wires (shielded)	1.0 ~ 1.5 mm ² (1.55 × 10 ⁻³ ~ 2.32 × 10 ⁻³ in ²)
AC Ez	4-core wires (shielded)	1.0 ~ 1.5 mm ² (1.55 × 10 ⁻³ ~ 2.32 × 10 ⁻³ in ²)

CAUTION

In case of using the shielded wires, it should be grounded.

Separation of communication and power cables

- If communication and power cables are installed alongside each other then there is a strong likelihood of operational faults developing due to interference in the signal wiring caused by electrostatic and electromagnetic coupling.
- The tables below indicates our recommendation as to appropriate spacing of communication and power cables where these are to be run side by side

Current capacity of power cable		Spacing
100V or more	10A	300 mm (11-13/16 inch)
	50A	500 mm (19-11/16 inch)
	100A	1 000 mm (39-3/8 inch)
	Exceed 100A	1 500 mm (59-1/16 inch)

NOTE

- The figures are based on assumed length of parallel cabling up to 100 m [328 ft]. For length in excess of 100 m [328 ft] the figures will have to be recalculated in direct proportion to the additional length of cable involved.
- If the power supply waveform continues to exhibit some distortion the recommended spacing in the table should be increased.
 - If the cable are laid inside conduits then the following point must also be taken into account when grouping various cable together for introduction into the conduits
 - Power cable(including power supply to air conditioner) and communication cables must not be laid inside the same
 - In the same way, when grouping the power wires and communication cables should not be bunched together.

CAUTION

If apparatus is not properly earthed then there is always a risk of electric shock, the grounding of the apparatus must be carried out by a qualified person.

Wiring of main power supply and equipment capacity

- Use a separate power supply for the Outdoor Unit and Indoor Unit.
- Bear in mind ambient conditions (ambient temperature, direct sunlight, rain water, etc.) when proceeding with the wiring and connections.
- The cable size is the minimum value for metal conduit wiring. The power cord size should be 1 rank thicker taking into account the line voltage drops. Make sure the power-supply voltage does not drop more than 10%.
- Specific wiring requirements should adhere to the wiring regulations of the region.
- Power supply cords of parts of appliances for outdoor use should not be lighter than polychloroprene sheathed flexible cord.
- Don't install an individual switch or electrical outlet to disconnect each of indoor unit separately from the power supply.

	The thickness of Minimum wire (mm ² [inch ²])			Leakage circuit breaker (4P ELCB)
	Main power wire	Branch wire	Ground wire	
1 Unit	2.5~16 [3.875 × 10 ⁻³ ~2.48 × 10 ⁻²]	-	2.5~4 [3.875 × 10 ⁻³ ~6.2 × 10 ⁻³]	Below 20~60 A 100 mA 0.1 sec
2 Unit	16~50 [2.48 × 10 ⁻² ~7.75 × 10 ⁻²]	-	4~10 [6.2 × 10 ⁻³ ~1.55 × 10 ⁻²]	Below 75~150 A 100 mA 0.1 sec
3 Unit	50~95 [7.75 × 10 ⁻² ~1.4725 × 10 ⁻¹]	-	10 [1.55 × 10 ⁻²]	Below 150~200 A 100 mA 0.1 sec
4 Unit	95~120 [1.4725 × 10 ⁻¹ ~1.86 × 10 ⁻¹]	-	10~16 [1.55 × 10 ⁻² ~2.48 × 10 ⁻²]	Below 200~250 A 100 mA 0.1 sec

Ground wire

- 1 The power wire Between the master outdoor unit and slave1 outdoor unit - minimum : 6 mm² [9.3 × 10⁻³ inch²]
- 2 The power wire Between the slave1 outdoor unit and slave2 outdoor unit - minimum : 4 mm² [6.2 × 10⁻³ inch²]
- 3 The power wire Between the slave2 outdoor unit and slave3 outdoor unit - minimum : 2.5 mm² [3.875 × 10⁻³ inch²]

- * The above standard is CV wire standard.
- * Please use the 3-phases 4-wires quadropole Leakage circuit breaker of circuit breaker.

! WARNING

- Follow ordinance of your governmental organization for technical standard related to electrical equipment, wiring regulations and guidance of each electric power company.
- Make sure to use specified cables for connections so that no external force is imparted to terminal connections. If connections are not fixed firmly, it may cause heating or fire.
- Make sure to use the appropriate type of overcurrent protection switch. Note that generated overcurrent may include some amount of direct current.

! CAUTION

- Some installation site may require attachment of an earth leakage breaker. If no earth leakage breaker is installed, it may cause an electric shock.
- Do not use anything other than breaker and fuse with correct capacity. Using fuse and wire or copper wire with too large capacity may cause a malfunction of unit or fire.

Field Wiring

- Outdoor : 220-240 V3~ 50Hz / 220 V3~ 60Hz
- Indoor : 220-240 V~ 50Hz / 220 V~ 60Hz

Single outdoor unit

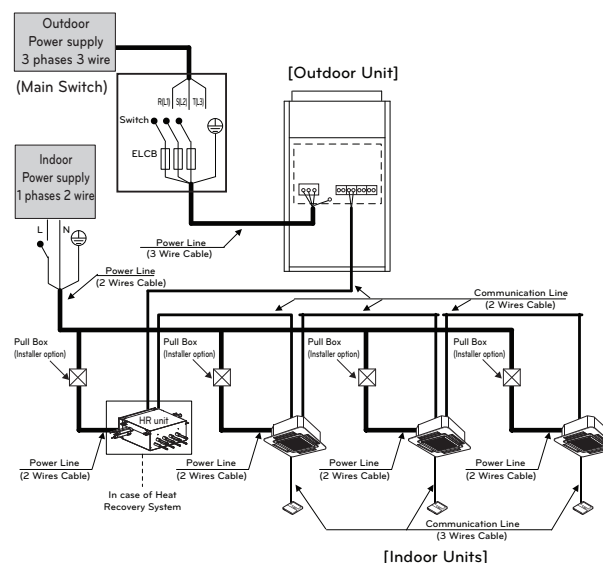

! WARNING

- Indoor Unit ground wires are required for preventing electrical shock accident during current leakage, Communication disorder by noise effect and motor current leakage (without connection to pipe).
- Don't install an individual switch or electrical outlet to disconnect each of indoor unit separately from the power supply.
- Install the main switch that can interrupt all the power sources in an integrated manner because this system consists of the equipment utilizing the multiple power sources.
- If there exists the possibility of reversed phase, lose phase, momentary blackout or the power goes on and off while the product is operating, attach a reversed phase protection circuit locally. Running the product in reversed phase may break the compressor and other parts.

Between Indoor and Master Outdoor unit

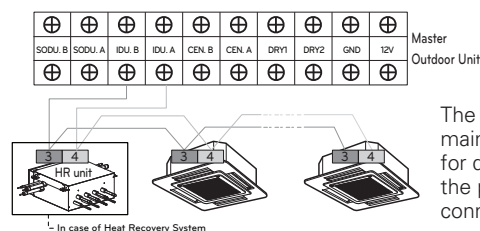

The GND terminal at the main PCB is a '-' terminal for dry contact, it is not the point to make ground connection.

Series outdoor units

When the power source is connected In series between the units.

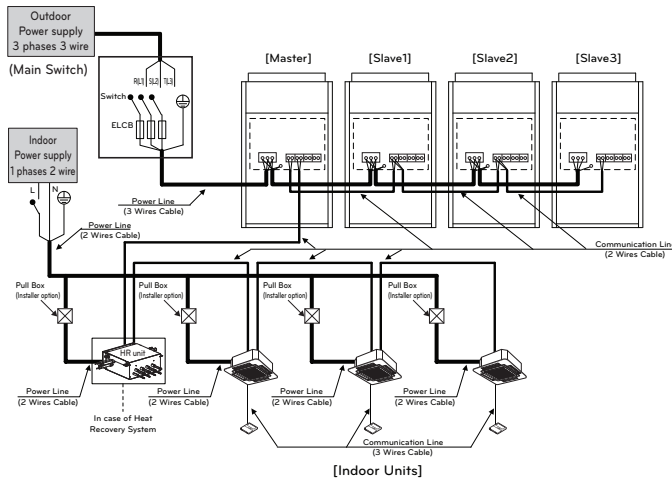

WARNING

When the total capacity is over than 68HP, Do not use single power source for connecting series units. The First terminal block could be burnt out.

When the power source is supplied to Each outdoor unit individually.

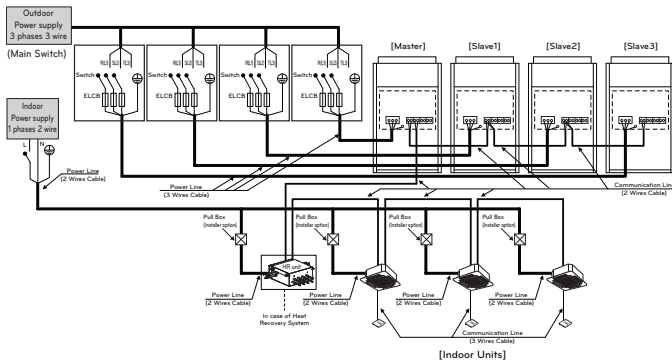

WARNING

- Indoor Unit ground wires are required for preventing electrical shock accident during current leakage, Communication disorder by noise effect and motor current leakage (without connection to pipe).
- Don't install an individual switch or electrical outlet to disconnect each of indoor unit separately from the power supply.
- Install the main switch that can interrupt all the power sources in an integrated manner because this system consists of the equipment utilizing the multiple power sources.
- If there exists the possibility of reversed phase, lose phase, momentary blackout or the power goes on and off while the product is operating, attach a reversed phase protection circuit locally. Running the product in reversed phase may break the compressor and other parts.

Between Indoor and Master Outdoor unit

The communication cables between indoor unit and master outdoor unit are possible to connect with BUS type or STAR type.

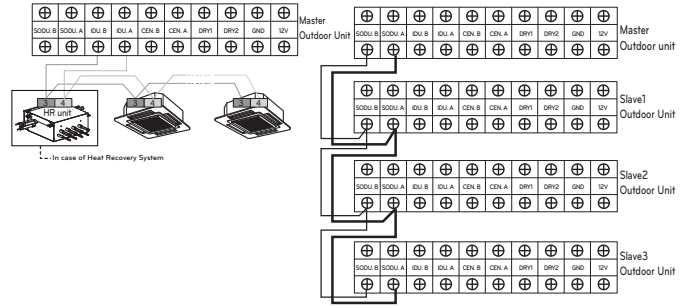

The GND terminal at the main PCB is a ' ' terminal for dry contact. It is not the point to make ground connection.

- Make sure that terminal number of master and slave outdoor units are matched.(A-A, B-B)

Example) Connection of communication cable

[BUS type]

- Connection of communication cable must be installed like below figure between indoor unit to outdoor unit.

[STAR type]

- Abnormal operation can be caused by communication defect, when connection of communication cable is installed like below figure(STAR type).

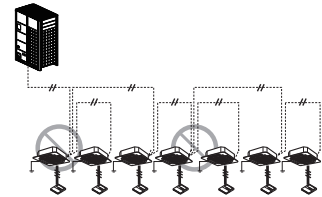
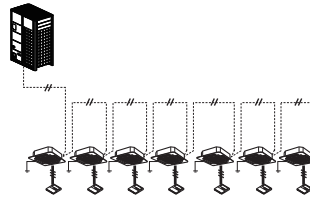

Example) Connection of power and communication cable (UXA)

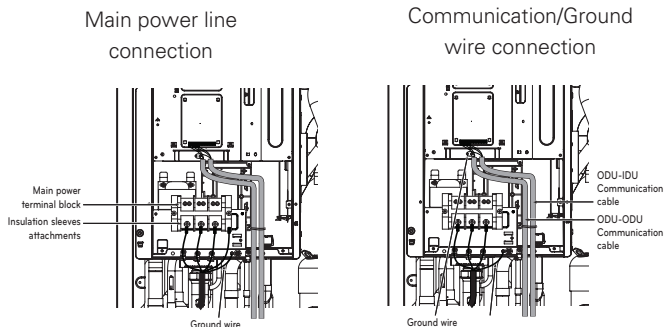
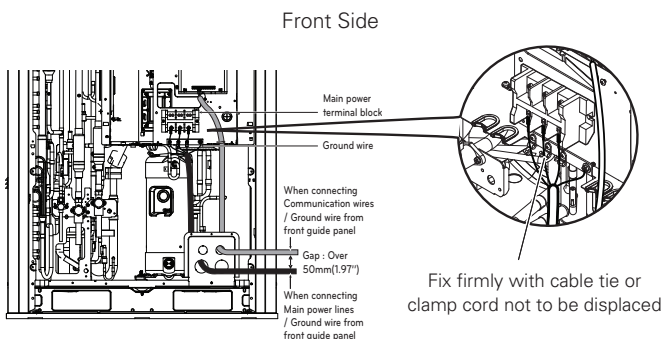
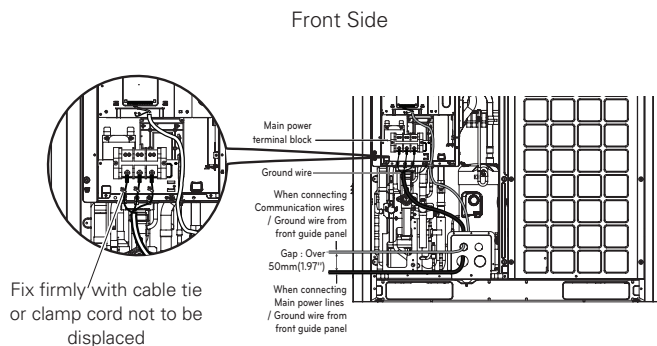
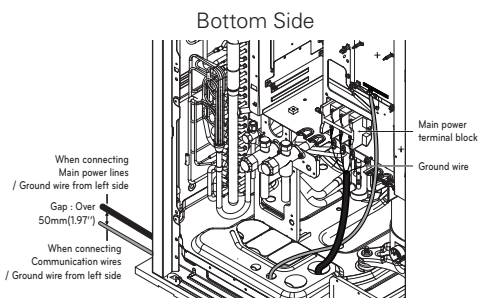

Main power line connection Communication/Ground wire connection

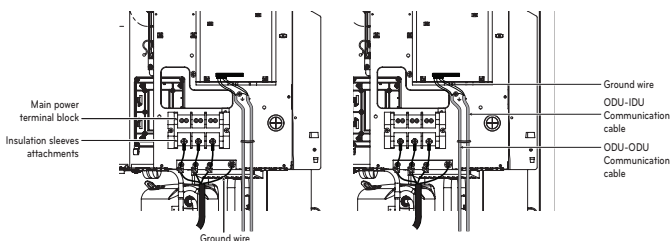

CAUTION
It should be wiring power cables or communication cables to avoid interference with the oil level sensor. Otherwise, That oil level sensor would be operated abnormally.

CAUTION
It should be wiring power cables or communication cables to avoid interference with the oil level sensor. Otherwise, That oil level sensor would be operated abnormally.

Checking the setting of outdoor units

Checking according to dip switch setting

- You can check the setting values of the Master outdoor unit from the 7 segment LED.
The dip switch setting should be changed when the power is OFF.

Checking the initial display

The number is sequentially appeared at the 7 segment in 5 seconds after applying the power. This number represents the setting condition.

[Main Board]

Example) Connection of power and communication cable (UXB)

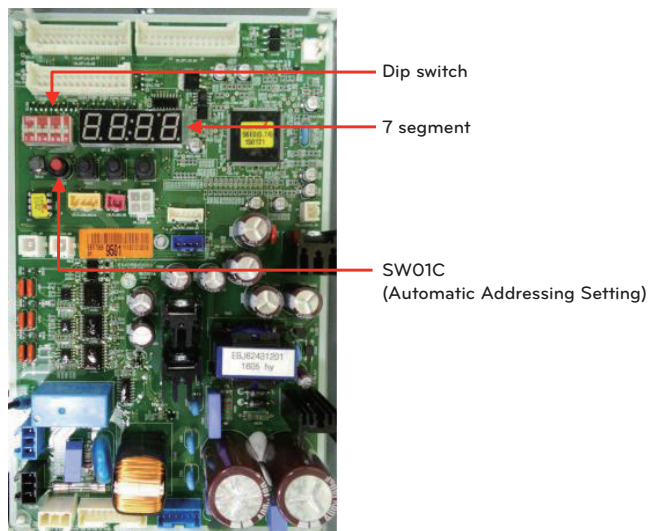
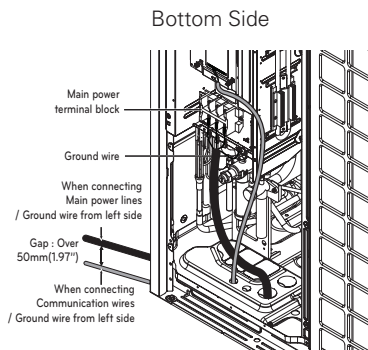

Quick control Setting

- In the factory setting, main PCB dip switch setting is all "OFF".
- Check and make sure that all the indoor unit model name are ARNU*****4.
 - Change the main PCB Dip switch No. 3 "OFF → ON" like below picture.
 - Push the reset button.

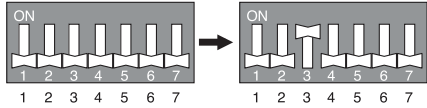
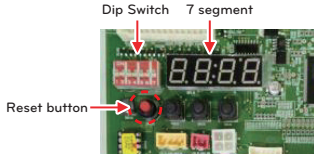

• Initial display order

Order	No	Mean
①	8~24	Master unit capacity
②	10~24	Slave 1 unit capacity
③	10~24	Slave 2 unit capacity
④	10~24	Slave 3 unit capacity
⑤	8~96	Total capacity
⑥	1	Cooling Only
	2	Heat Pump (Factory Setting)
	3	Heat Recovery
⑦	38	380V model
	46	460V model
	22	220V model
⑧	35	Product type

- Example) ARUM620BTE5
62hp 220V Heat Recovery System (Master unit : 18hp, Slave 1: 16hp, Slave 2 : 14hp, Slaver 3 : 14hp)

①	②	③	④	⑤	⑥	⑦	⑧
18	16	14	14	62	3	22	35

Master/Slave dip switch setting

• Master Unit

Dip switch setting	ODU Setting
	Heat Pump System (Factory Setting)

• Slave Unit

Dip switch setting	ODU Setting
	Slave 1
	Slave 2
	Slave 3

* Heat Recovery installation

- ① Turn on the dip s/w No 4.

Dip switch setting	ODU Setting
	Setting Heat pump system or Heat Recovery system (Installer Setting)

- ② The factory setting display is appeared "HP".
- ③ Change "HP" into "HR" display pushing ► button and then push confirm button.
- ④ Turn off the dip s/w No 4. and Push reset button to restart the system. (If you turn on the dip s/w No 4, you can make sure "HR" or "HP" display later.)

Setting For Heat Recovery Unit (Refer Only Heat Recovery Installation) [Heat Recovery (HR) Unit Board]

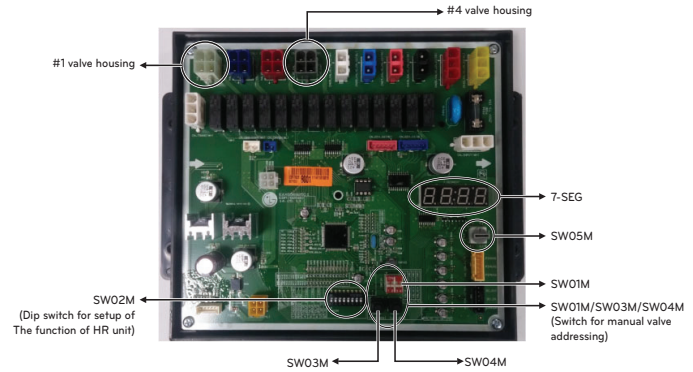

Switch for setup of HR Unit

Main function of SW02M

ON S/W	Selection	
No.1	Method for addressing valves of an HR unit (Auto/Manual)	
No.2	Model of HR unit	
No.3	Model of HR unit	
No.4	Model of HR unit	
No.5	Valve group setting	
No.6	Valve group setting	
No.7	Use only in factory production (preset to "OFF")	Zoning setting ("ON")
No.8	Use only in factory production (preset to "OFF")	

- 1 Selection of the method for addressing valves of an HR unit (Auto/Manual)

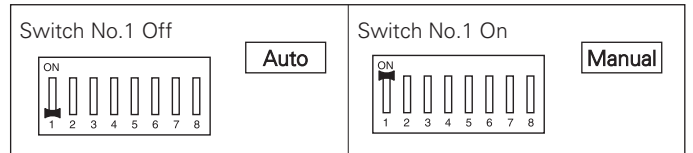

- 2 Setting the zoning control

	DIP Switch setting	
Normal control		
Zoning control		Turn the dip switch of the zoning branch on. Ex) Branch 1,2 are zoning control.

* Zoning control

This function is used to connect multiple indoor units to one pipe.

3 Selection of the model of HR unit

	 (For 2 branches) PRHR022 PRHR022A	 (For 3 branches) PRHR032 PRHR032A	 (For 4 branches) PRHR042 PRHR042A
Initial Setting			
1 branches Connected			
2 branches Connected			
3 branches Connected			
4 branches Connected			

* Each model is shipped with the switches No.2 and No.3 pre-adjusted as above in the factory.

WARNING

- If you want to use a PRHR032 or PRHR032A for 2 branches HR unit after closing the 3rd pipes, set the dip switch for 2 branches HR unit.
- If you want to use a PRHR042 or PRHR042A for 3 branches HR unit after closing the 4th pipes, set the dip switch for 3 branches HR unit.
- If you want to use a PRHR042 or PRHR042A for 2 branches HR unit after closing the 3rd and 4th pipes, set the dip switch for 2 branches HR unit.
- The unused port must be closed with a copper cap, not with a plastic cap.

4 Setting the Valve Group.

	DIP S/W setting	Example
Not control		
No.1, 2 Valve Control		
No.2, 3 Valve Control		
No.3, 4 Valve Control		
No.1, 2 Valve / No.3, 4 Valve Control		

* Setting the Valve Group
This function is used to connect one indoor unit to two pipes. (Large capacity indoor unit over 56 kBTu must be connected to two pipes.)

NOTE

If the large capacity indoor units are installed, below Y branch pipe should be used.

Y branch pipe

(Unit: mm (inch))

Models	Low pressure Gas pipe	Liquid pipe	High pressure Gas pipe
ARBLB03321			

SW05M (Rotary S/W for addressing HR unit)

Must be set to '0' when installing only one HR unit.
When installing multiple HR units, address the HR units with sequentially increasing numbers starting from '0'.

Ex) Installation of 3 HR units

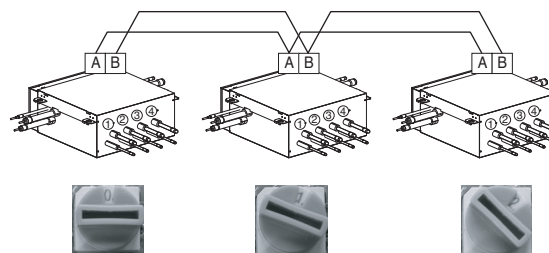

SW01M/SW03M/SW04M (Dip S/W and tact S/W for manual valve addressing)





1 Normal setting (Non-Zoning setting)

- Set the address of the valve of the HR unit to the central control address of the connected indoor unit.
- SW01M: selection of the valve to address
- SW03M: increase in the digit of 10 of valve address
- SW04M: increase in the last digit of valve address
- Prerequisite for manual valve addressing : central control address of each indoor unit must be preset differently at its wired remote control.

S/W No.	Setup
No.1	Manual addressing of valve #1
No.2	Manual addressing of valve #2
No.3	Manual addressing of valve #3
No.4	Manual addressing of valve #4
SW03M	Increase in the digit of 10 of valve address
SW04M	Increase in the last digit of valve address

2 Zoning setting

- Set the address of the valve of the HR unit to the central control address of the connected indoor unit.
- SW01M : selection of the valve to address
- SW03M : increase in the digit of 10 of valve address
- SW04M : increase in the last digit of valve address
- SW05M : Rotary S/W
- Prerequisite for manual valve addressing : central control address of each indoor unit must be preset differently at its wired remote control.

	S/W No.	Setup
 SW01M	No.1	Manual addressing of valve #1
	No.2	Manual addressing of valve #2
	No.3	Manual addressing of valve #3
	No.4	Manual addressing of valve #4
 SW03M	SW03M	Increase in the digit of 10 of valve address
 SW04M	SW04M	Increase in the last digit of valve address
 SW05M	SW05M	Manual addressing of zoning indoor units

Automatic Addressing

The address of indoor units would be set by Automatic Addressing

- Wait for 3 minutes after supplying power. (Master and Slave outdoor units, indoor units)
- Press RED button of the outdoor units for 5 seconds. (SW01C)
- A "88" is indicated on 7-segment LED of the outdoor unit PCB.
- For completing addressing, 2~7 minutes are required depending on numbers of connected indoor units
- Numbers of connected indoor units whose addressing is completed are indicated for 30 seconds on 7-segment LED of the outdoor unit PCB
- After completing addressing, address of each indoor unit is indicated on the wired remote control display window. (CH01, CH02, CH03,, CH06 : Indicated as numbers of connected indoor units)

[Main Board]

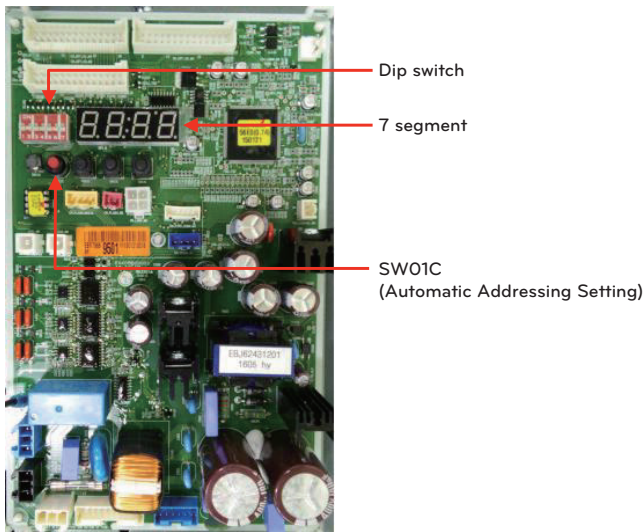

The Procedure of Automatic Addressing

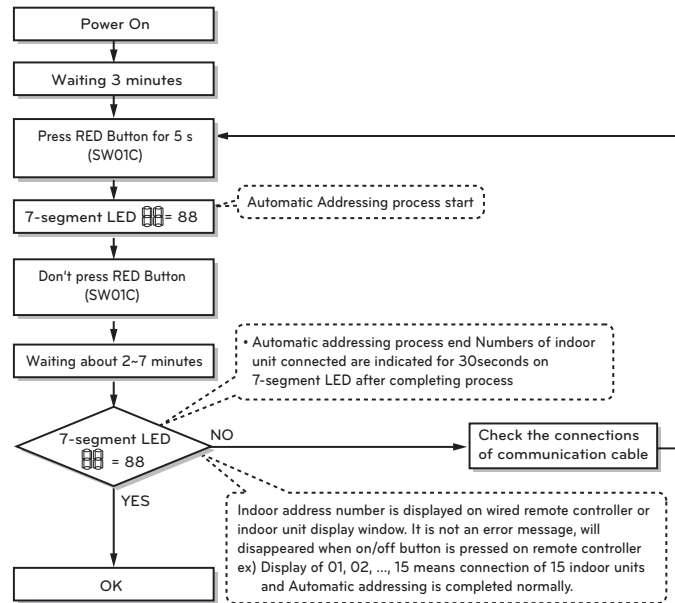

CAUTION

- In replacement of the indoor unit PCB, always perform Automatic addressing setting again (At that time, please check about using Independent power module to any indoor unit.)
- If power supply is not applied to the indoor unit, operation error occur.
- Automatic Addressing has to be performed after more than 3 minutes to improve indoor unit communication when initial power is supplied.
- Please be sure that all the dip switch (1~7) of master outdoor unit is OFF before Automatic Addressing setting

Setting For Heat Recovery Unit (Refer Only Heat Recovery Installation)

Automatic pipe detection

- 1 Turn No.1 of DIP s/w SW02M of HR unit PCB off.
- 2 Confirm that the setting of No.2, 3 of SW02M corresponds with the Type of the valve connection.
- 3 Reset the power of HR unit PCB
- 4 Master Out door unit PCB DIP switch on : No.5
- 5 Select the mode using '▶', '◀' Button : "Idu" Push the '●' button
- 6 Select the "Id 5" function using '▶', '◀' Button : "Ath" or "Atc" Push the '●' button.
Outdoor temperature is over 15°C(59°F) : "Atc" Using (If it fail, use "Ath")
Outdoor temperature is below 15°C(59°F) : "Ath" Using (If it fail, use "Atc")
- 7 Select the mode using '▶', '◀' Button : "Idu" Push the '●' button
- 8 Select the "Id 6" function using '▶', '◀' Button : "StA" Push the '●' button
- 9 System is operated after "88" is displayed on 7-SEG of the outdoor unit main PCB.
- 10 Pipe detection process is proceeded.
- 11 5~30 minutes are required depending on the number of the indoor units and outdoor temperature.
- 12 The number of the indoor units connected is displayed on 7-Segment of the outdoor unit main PCB for about 1 minute
 - For a HR unit, the number of the indoor units connected to each HR unit is displayed.
 - '200' is displayed in case of auto pipe detecting error, and auto pipe detection process is completed after '88' is disappeared.

* Auto pipe detection function : the function that sets connection relationship automatically between the indoor unit and HR unit.

! WARNING

- Execute auto addressing and auto pipe detection again whenever the indoor PCB and HR unit PCB is replaced.
 - Operation error occurs unless power is supplied to the indoor and HR units.
- Error No.200 occurs if the number of connected indoor units and that of scanned indoor units are different.
- If auto pipe detection process fails, complete it with manual pipe detection (see Manual pipe detection part).
- If auto pipe detection process is completed normally, manual pipe detection is not required.
- If you want to do auto pipe detection again after auto pipe detection fails, do after reset of outdoor unit by all means.
- During 5 minutes after pipe detection is completed, do not turn off the main unit PCB to save the result of pipe detection automatically.

Manual pipe detection

- 1 Enter the central control address into each indoor unit using its wired remote controller.
- 2 Turn No.1 of DIP s/w SW02M of HR unit PCB on.
- 3 Reset the power of HR unit PCB.
- 4 On the HR unit PCB, manually set address of each valve of the HR unit to the central control address of the indoor unit connected to the valve.
- 5 Reset the power of outdoor unit PCB.
- 6 The number of the indoor unit installed is displayed after about 5 minutes.
Ex) HR → The number of the indoor
- 7 Reset the power of outdoor unit PCB, HR unit.
- 8 Manual pipe detection is completed

! WARNING

- In case that central controller is not installed, firstly set up central controller's setting to make address setting of indoor units.
- In case that central controller is installed, please set central control address in wired remote control of indoor unit.
- Do not set central control address of indoor unit to '0xFF'. (If the address is '0xFF', pipe detection will not be completed properly.)
- HR unit's manual pipe address is set by the central control address of indoor units.
- Address of valve which is not connected with indoor unit should be set differently with the address of a valve which is indoor unit connected (If address is overlapped valve will not work properly)
- If there occurs some error during pipe detection process, it means pipe detection process is not properly finished.
- If an error occurred, it means that manual pipe setting is not completed.
- During 5 minutes after pipe detection process is completed, do not turn off the main outdoor unit's PCB to save the result of pipe detection automatically.

Flow chart of auto pipe detection process

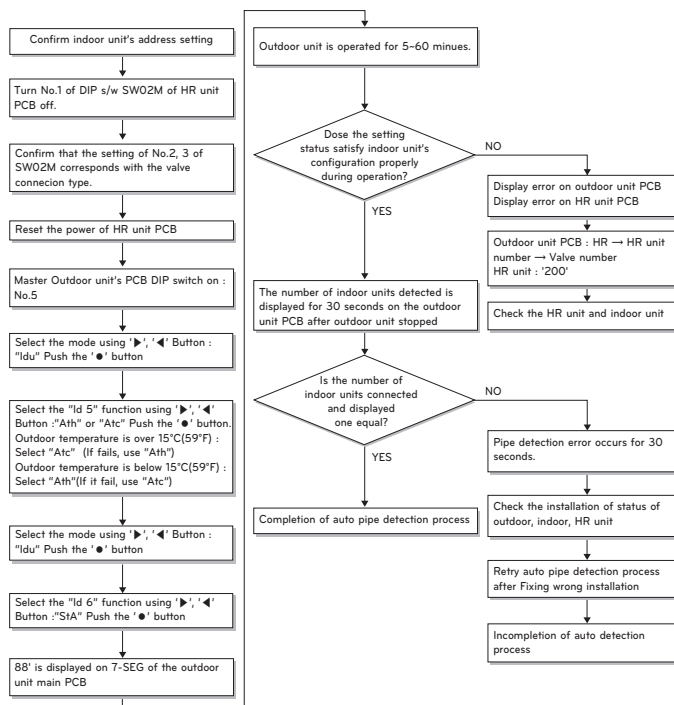

* It is possible to be generated mode changing noise of heating and cooling which is normal. There is no mode changing noise at normal operation.

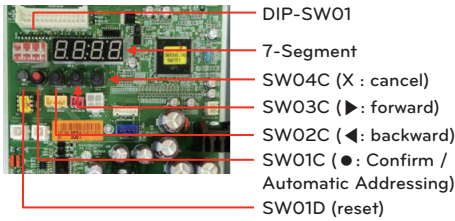

Flow chart of manual addressing for pipe detection

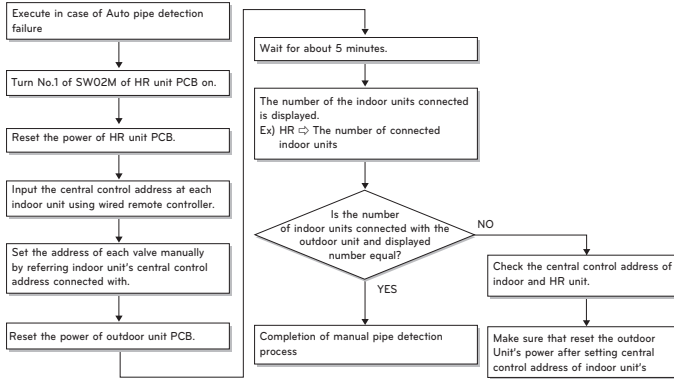

Example of manual valve addressing (Non-Zoning setting)

(In case that an indoor unit of central control address "11" is connected to a valve #1 of an HR unit)

- Prerequisite for manual valve addressing: central control address of each indoor unit must be preset differently at its wired remote control.

No.	Display and setup	Setup and Contents
1		- Operation: None - Display: None
2		- Operation: Turn dip S/W No.1 on to address valve #1 - Display: Existing value saved in EEPROM is displayed in 7-SEG.
3		- Operation: Set the digit of 10 to the number in Group High data of the wired remote control connected to the corresponding indoor unit to the valve #1 by pressing left tack S/W. - Display: Digit increasing with the times of pressing tack S/W is displayed in left 7-SEG
4		- Operation: Set the digit of 1 to the number in Group Low data of the wired remote control connected to the corresponding indoor unit to the valve #1 by pressing right tack S/W. - Display: Digit increasing with the times of pressing tack S/W is displayed in right 7-SEG
5		- Operation: Turn dip S/W No.1 off to save the address of valve #1 - Display: "11" displayed in 7-SEG disappears

- Above setup must be done for all HR unit valves.
- The valve that is not connected with any indoor unit should be addressed with any other number than used address numbers of the valves connected with indoor units.
(The valves does not work if the address numbers are same.)

Example of manual valve addressing (Zoning setting)

(In case that an indoor unit of central control address "11" is connected to a valve #1 of an HR unit)

Zoning control is connecting 2 or more indoor units at one pipe of HR unit. In case of Zoning control, in order to set controls with multiple indoor units connection uses the rotary switch. Namely, only the rotary switch changes from same valve set condition and set indoor units connection.

- 1 On dip switch of the corresponding valves and sets the rotary switch at 0.
- 2 Setting the number with tact switch.
- 3 In case of addition of indoor units to same port, increases 1 with the rotary switch and sets number with tact switch.
- 4 In case of checking the number which the corresponding valve is stored, turn on dip switch and set the number of rotary switch.
- 5 Indoor units set available 7 per a port(rotary switch 0~6), in case of setting above of 7 with rotary switch, it will display error.
- 6 Setting the rotary switch on original condition(HR unit number set conditions) after all finishing a piping setting.
- 7 The rotary switch set value of above number of indoor units which is connected with FF and prevents a malfunction.
(Example: The case where 3 indoor units is connected in piping 1, sets from rotary switch 0,1,2 and 3,4,5 with FF set)
- Prerequisite for manual valve addressing: central control address of each indoor unit must be preset differently at its wired remote control.

No.	Display and setup	Setup and Contents
1		- Operation: None - Display: None
2		- Operation : Turn dip S/W No.1 on to address valve #1 - Display : Existing value saved in EEPROM is displayed in 7-SEG.
3		- Operation : Set the digit of 10(1) to the number in Group High data of the wired remote control connected to the corresponding indoor unit to the valve #1 by pressing left tack S/W. - Display : Digit increasing with the times of pressing tack S/W is displayed in left 7-SEG.
4		- Operation : SW05M : 1 - Display : Display former value.
5		- Operation : Setting No. using SW03M and SW04M, SW05M : 1 - Display : Display setting value.
6		- Operation : Turn dip S/W No.1 off to save the address of valve #1 - Display : "11" displayed in 7-SEG disappears.
7		- Operation : Return valve of addressing HR unit. - Display : None

- Above setup must be done for all HR unit valves.
- The valve that is not connected with any indoor unit should be addressed with any other number than used address numbers of the valves connected with indoor units.
(The valves does not work if the address numbers are same.)

Example of checking valve address

(In case that an indoor unit of central control address "11" is connected to a valve #1 of an HR unit)

No.	Display and setup	Setup and Contents
1		- Operation: Turn dip S/W No.1 on. - Display: "11" is displayed in 7-SEG
2		- Operation: Turn dip S/W No.1 off. - 7-SEG disappeared

Identification of Manual Valve ID (Address)

No.	Display and setup	Setup and Contents
1		- Operation: more than 2 dip switches turned on. - Display: "Er" is displayed in 7-SEG

Method of checking the pipe detection result at outdoor unit

- 1 Wait for 5 minutes, after Pipe detection is completed.
- 2 Turn on the No.10,14,16 DIP S/W of SUB PCB at master unit
- 3 Check the data on 7- segment, switching rotary 01,02.

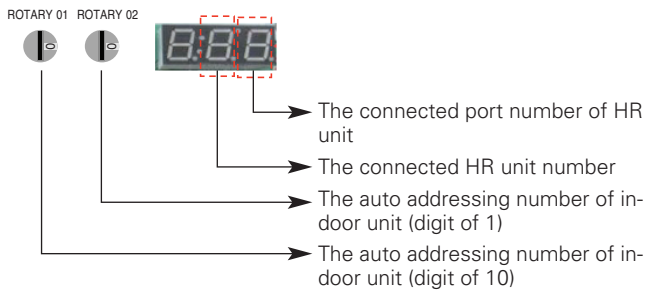

Setting method of Master indoor unit in zoning

- 1 Turn dip switch 5,6,10 on at system off.
- 2 Set the left Rotary switch for HR unit.(Rotary switch No. "0" ' HR unit No. "1")
- 3 Set the right Rotary switch for IDU unit.(Rotary switch No. "0" ' HR unit branch No. "1")
- 4 Display the Master IDU No. of the HR unit on 7segment.(Default display is "00" on 7segment)
- 5 Press the black button.(The IDU No. increase every 1 second in the zoning)
- 6 Set the Master IDU(Press the red button during 1.5seconds stop twinkling)

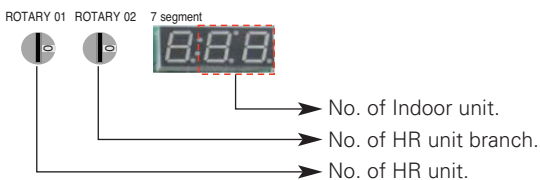

CAUTION

- Waiting for 80seconds after power on.
- The zoning information and Master IDU information remove from EEPROM after Auto-addressing.
- If there is installed the central control, it is impossible setting of Master IDU in zoning.

Group Number setting

Group Number setting for Indoor Units

- Confirm the power of whole system(Indoor Unit, Outdoor Unit) is OFF, otherwise turn off.
- The communication cables connected to CEN.A and CEN.B terminal should be connected to central control of Outdoor Unit with care for their polarity (A-A, B-B).
- Turn the whole system on.
- Set the group and Indoor Unit number with a wired remote control.
- To control several sets of Indoor Units into a group, set the group ID from 0 to F for this purpose.

Outdoor Units (External PCB)

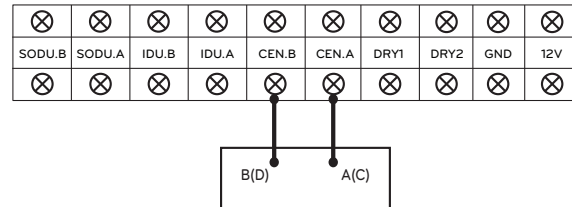

Example) Group number setting

1 E
Group Indoor unit

- 1st number indicate the group number
- 2nd number point out indoor unit number

Group recognizing the central controller	
No.0 group (00~0F)	
No.1 group (10~1F)	
No.2 group (20~2F)	
No.3 group (30~3F)	
No.4 group (40~4F)	
No.5 group (50~5F)	
No.6 group (60~6F)	
No.7 group (70~7F)	
No.8 group (80~8F)	
No.9 group (90~9F)	
No. A group (A0~AF)	
No. B group (B0~BF)	
No. C group (C0~CF)	
No. D group (D0~DF)	
No. E group (E0~EF)	
No. F group (F0~FF)	

WARNING

- Valve address and central control address of its corresponding indoor unit should be set identical in manual addressing.

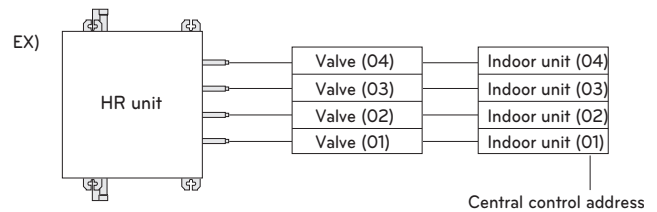

Setting the optional function

Select the mode/function/option/value using '▶', '◀' Button and confirm that using the '●' button after dip switch No.5 is turned on.

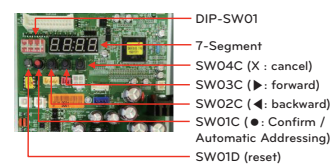
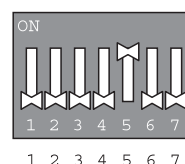

Optional Mode Selection		Function Selection		Option Selection		Remarks			
Content	Display (⊙)	Content	Display (◀▶→⊙)	Default	Optional (◀▶→⊙)				
FDD	Fdd	Automatic Refrigerant Charging (Cooling)	Fd 1	-	-	* Refer FDD guidance			
		Automatic Refrigerant Charging (Heating)	Fd 2	-	-				
		Refrigerant Amount Check (Cooling)	Fd 3	-	-				
		Refrigerant Amount Check (Heating)	Fd 4	-	-				
		ITR (Cooling, Heating)	Fd 7	-	-				
		All IDU operation (Cooling)	Fd 8	-	-		Compulsory Operation for 1 hour		
		All IDU operation (Heating)	Fd 9	-	-				
Installation	Func	Cool & Heat Selector	Fn 1	oFF	oFF, oP1~oP2	Saving in EEPROM			
		High Static Pressure Compensation mode	Fn 2	oFF	oFF, oP1~oP3				
		Night Low Noise mode	Fn 3	oFF	oFF, oP1~oP12				
		Overall Defrost mode	Fn 4	North America: oFF Europe: oFF Tropical: oN	on, oFF				
		ODU address setting	Fn 5	0	254				
		Snow Removal & Rapid Defrost	Fn 6	oFF	oFF, oP1~oP3				
		Airflow Adjusting for IDU (Heating capacity up)	Fn 7	oFF	on, oFF				
		Target Pressure Adjusting	Fn 8	oFF	oFF, oP1~oP6				
		Low Ambient Kit	Fn 9	oFF	on, oFF				
		High Efficiency Mode (Cooling Operation)	Fn 10	oFF	on, oFF				
		Auto Dust Removal Mode	Fn 11	oFF	oFF, oP1~oP5				
		Compressor Max. Frequency Limit	Fn 12	oFF	oFF, oP1~oP9				
		ODU Fan Max. RPM Limit Mode setting	Fn 13	oFF	oFF, oP1~oP7				
		Smart Load Control Mode setting	Fn 14	oFF	oFF, oP1~oP3				
		Humidity Reference Mode setting	Fn 16	on	on, oFF				
		Central Control Connection at Indoor Unit side	Fn 19	oFF	oFF, on				
		Compressor Input Current Limit mode	Fn 20	oFF	oFF, oP1~oP10				
		Power Consumption Display on wired remote controller	Fn 21	SPL0	SPL0, SPL1 [Pd10~Pd11]				
		Overall Defrost Operating in Low temperature (Heating)	Fn 22	oFF	on, oFF				
		Optional Base panel Heater	Fn 23	oFF	on, oFF				
		User	Idu	Comfort Cooling Mode setting	Id 10		EACH	* Refer Comfort Cooling guidance	Saving in EEPROM
		Service	SvC	Vaccum Mode	SE 3		vACC	-	1time / 1 Selection

CAUTION

- To perform the optional function, be sure that All the IDU is off mode, unless the function will not be performed.

Cool & Heat selector

Mode setting method

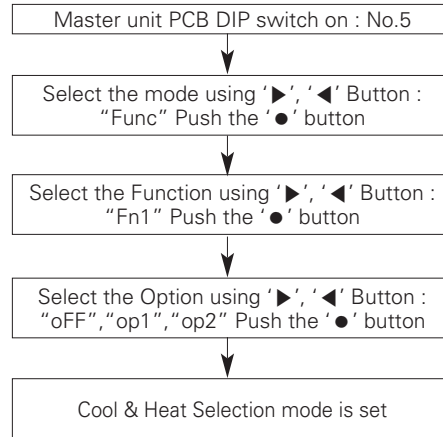

Function setting

Switch Control		Function		
Switch (Up)	Switch (Down)	oFF	oP1(mode)	oP2(mode)
Right side (On)	Left side (On)	Not operate	Cooling	Cooling
Right side (On)	Right side (On)	Not operate	Heating	Heating
Left side (Off)	-	Not operate	Fan mode	Off

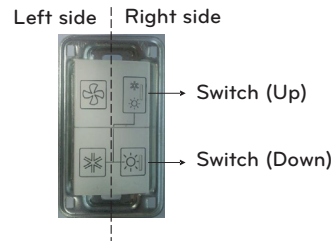

CAUTION

- Ask an authorized technician to setting a function.
- If do not use a function, set an off-mode.
- If use a function, first install a Cool & Heat selector.

* Functions save in EEPROM will be maintained continuously, though the system power was reset.

High Static Pressure Compensation mode

This function secures the air flow rate of ODU, in case static pressure has been applied like using duct at fan discharge of ODU.

Static pressure compensation mode setting method

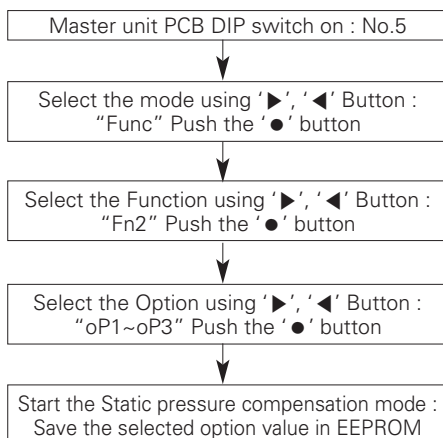

FAN Maximum RPM of each step

Chassis		UXA	UXB
Max. RPM	Standard	880	1000
	Overload / Low Temperature	880	1150
	op1	910	1040
	op2	930	1070
	op3	950	1100

Night Low Noise Function

In cooling mode, this function makes the ODU fan operate at low RPM to reduce the fan noise of ODU at night which has low cooling load.

Night low noise function setting method

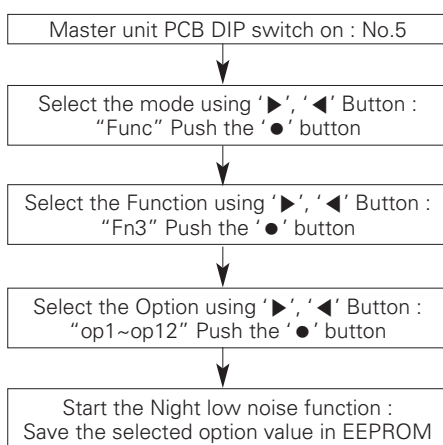

Time Settings

Step	Judgment Time(Hr)	Operation Time(Hr)
op1	8	9
op2	6.5	10.5
op3	5	12
op4	8	9
op5	6.5	10.5
op6	5	12
op7	8	9
op8	6.5	10
op9	5	12
op10	Continuous operation	
op11	Continuous operation	
op12	Continuous operation	

Noise

Chassis	UXA	UXB	
Capacity	8~12hp	14~20hp	22~26hp
Step	Noise(dBA)		
op1~op3,op10	55	59	60
op4~op6,op11	52	56	57
op7~op9,op12	49	53	55

CAUTION

- Request installer to set the function during installation.
- If ODU RPM changes, cooling capacity may go down.

Overall defrost mode

Mode setting method

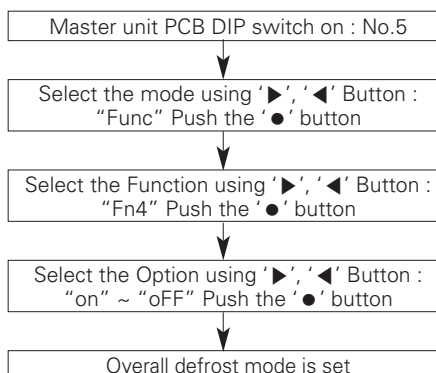

Mode setting

- on: Operate overall defrost
- off: Operate partial defrost

CAUTION

- Ask an authorized technician to setting a function.

Setting the ODU address

Mode setting method

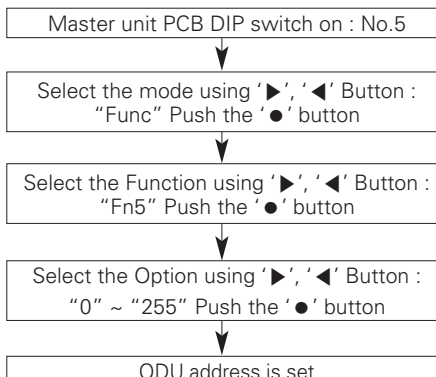

CAUTION

- Ask an authorized technician to setting a function.
- If use a function, first install a Central controller.

Snow removal & rapid defrost

Mode setting method

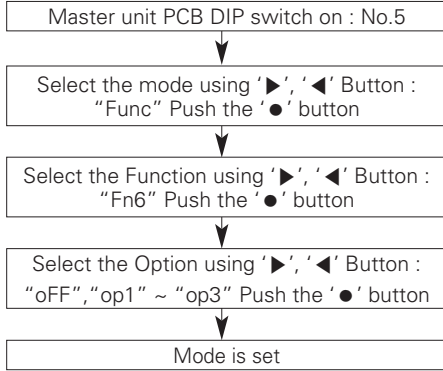

Mode setting

setting	Mode
oFF	Not setting
op1	Snow removal mode
op2	Rapid defrost mode
op3	Snow removal mode. + Rapid defrost mode.

CAUTION

- Ask an authorized technician to setting a function.
- If do not use a function, set an off-mode.

Setting Capacity Up Airflow Adjusting for IDU (Heating)

If the operation of indoor unit is more than 130%, the air flow is operated as low in the all indoor units.

Mode setting method

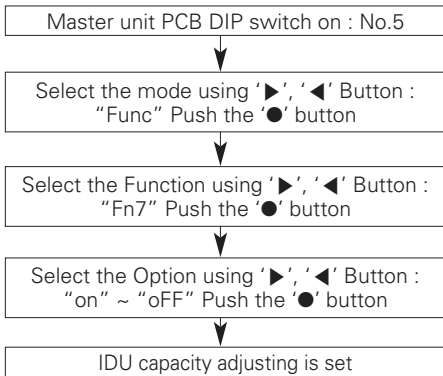

Step	Mode
OFF	Not setting
ON	Low capacity mode

CAUTION

- Ask an authorized technician to setting a function.

Target pressure adjusting

Mode setting method

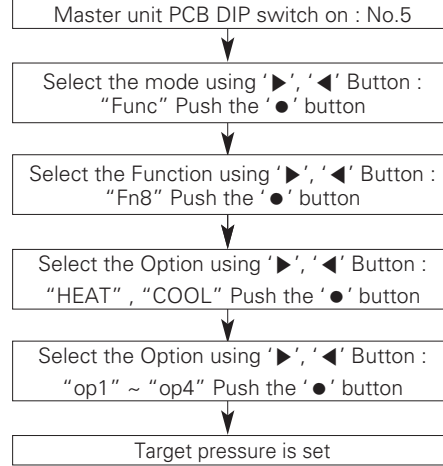

Setting

Mode	Purpose		Condensing temperature variation	Evaporating temperature variation
	Heat	Cool		
op1	Increase capacity	Increase capacity	+2°C (35.6°F)	-3°C (37.4°F)
op2	Decrease power consumption	Increase capacity	+2°C (35.6°F)	-1.5°C (-34.7°F)
op3	Decrease power consumption	Decrease power consumption	-4°C (-39.2°F)	+2.5°C (36.5°F)
op4	Decrease power consumption	Decrease power consumption	-6°C (-42.8°F)	-4.5°C (-40.1°F)

CAUTION

- Ask an authorized technician to setting a function.
- If do not use a function, set an off-mode.
- Change a power consumption or capacity.

Low Ambient Kit

Mode setting method

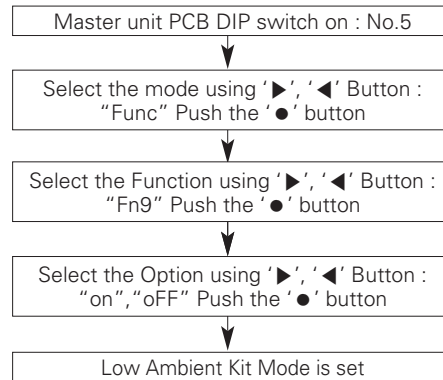

* Reference for functional logic of I/O Module

High Efficiency Mode (Cooling Operation)

Target low pressure will change according to ODU temperature during the cooling operation.

Mode setting method

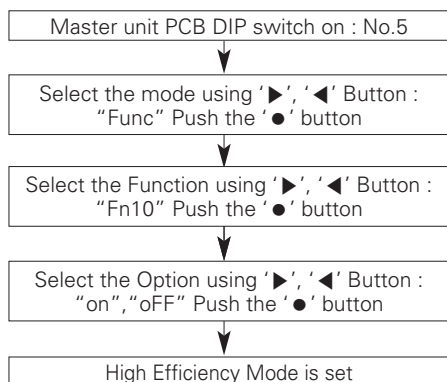

Auto Dust Removal Mode

The ability to set reverse run outdoor fan to remove dust, heat exchanger.

Mode setting method

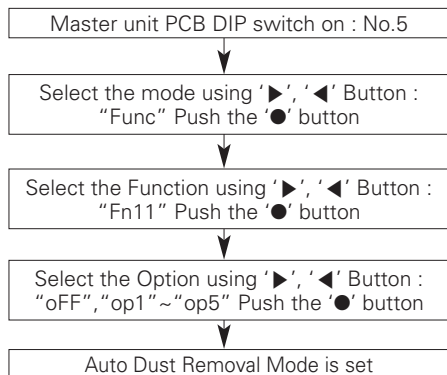

Mode Setting

Setting	Operation time	Operating time	Repeat cycle	Detail of function
op1	Stop +2hour	5minutes	2hour	After product stopped 2 hour, fan operating 5min(Repeated every 2 hours)
op2	stop +5minutes	3minutes	Twice in 2 hour	after product stopped 5 minutes, fan operating 3min (Limited to two times within 2 hours)
op3	stop +5minutes	3minutes	1 time	after product stopped 2 hour, fan operating 5min(Repeated every 2 hours)
op4	Stop +1minutes	1minutes	1 time	after product stopped 5 minutes, fan operating 3min(when io module connection/one-time operation)
op5	Stop +1minutes	1minutes	Low speed	after product stopped 1minutes, fan operating 1min(every time the product stops)

Compressor Max. Frequency Limit

Mode setting method

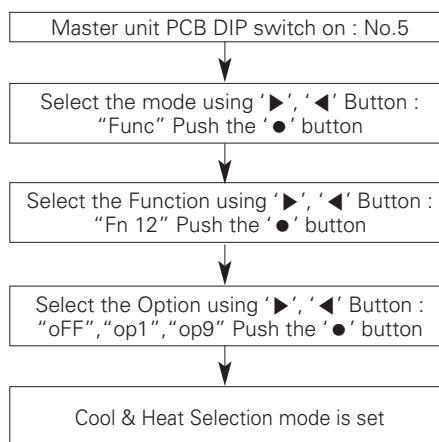

Function setting

Setting	Inverter (Hz)
oFF	-
op1	143 Hz
op2	135 Hz
op3	128 Hz
op4	120 Hz
op5	113 Hz
op6	105 Hz
op7	98 Hz
op8	90 Hz
op9	83 Hz

CAUTION

- Ask an authorized technician to setting a function.
- If use a function, first install a Central controller.

ODU Fan Max. RPM Limit

Mode setting method

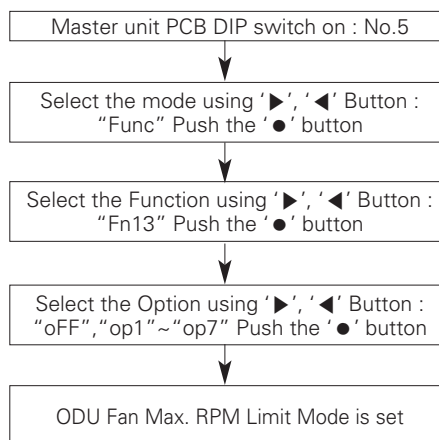

MAX. RPM Limit Setting

Chassis		UXA	UXB
Fan MAX. RPM Limit (RPM)	oFF	880	1000
	oP1	-20	-50
	oP2	-40	-100
	oP3	-60	-150
	oP4	-80	-200
	oP5	-100	-250
	oP6	-120	-300
	oP7	-140	-350

SLC (Smart Load Control)

Function for set the variable target pressure which for the high efficiency and comfort operation depend on ODU load.

Mode setting method

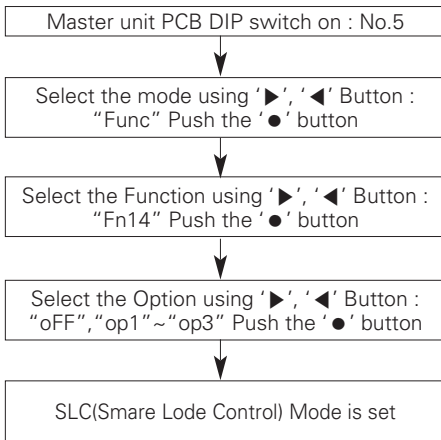

SLC(Smare Lode Control) Mode

Setting	Mode	Detail of function
oFF	Not Setting	-
oP1	Smooth Mode	Slowly control, a target pressure value
oP2	Normal Mode	Normal control, a target pressure value
oP3	Peak Mode	Fast control, a target pressure value

Humidity Reference

Mode setting method

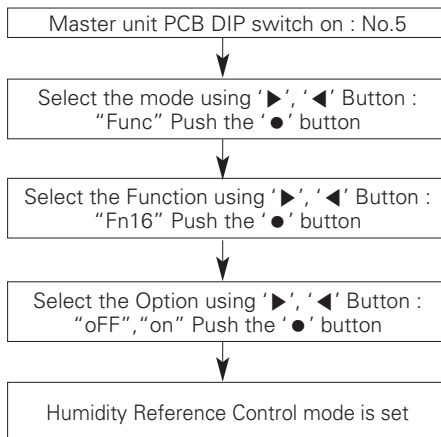

Mode setting

- on:using humidity sensor
- oFF:not setting

<Using of humidity sensor>

- When used cooling operation of SLC function,it will improve energy efficiency because evaporation temperature will be decreased
- When used heating operation in case of high humidity condition, defrost will be delayed because target high/low pressure will be changed.

Central Control Connection at Indoor Unit side

Mode setting method

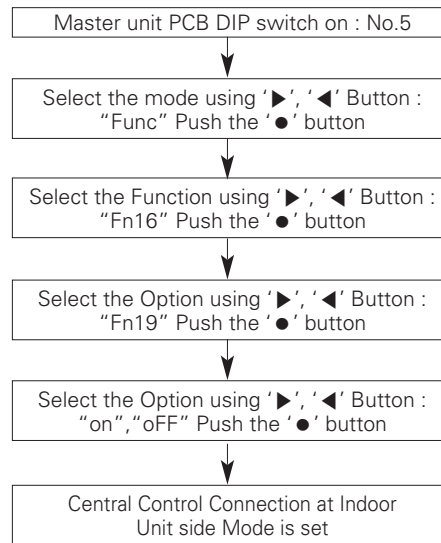

Compressor Input Current Limit

System Input Current Control

Mode setting method

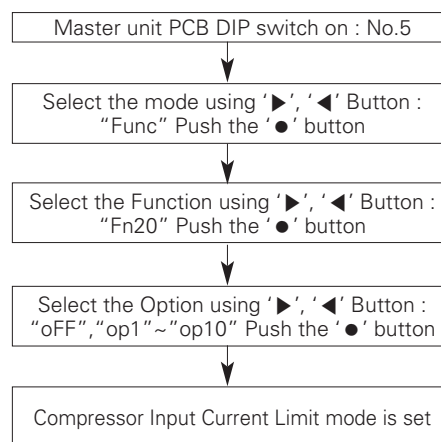

Compressor Input Current Limit

Mode	Compressor Input Current Limit
op1	95%
op2	90%
op3	85%
op4	80%
op5	75%
op6	70%
op7	65%
op8	60%
op9	55%
op10	50%

The current limits of each Compressor

Ex)16A Set op6 >11.2A

CAUTION

- Ask an authorized technician to setting a function.
- If do not use a function, set an off-mode.
- If use a function, capacity may go down.

Power Consumption Display on wired remote controller

Mode setting method

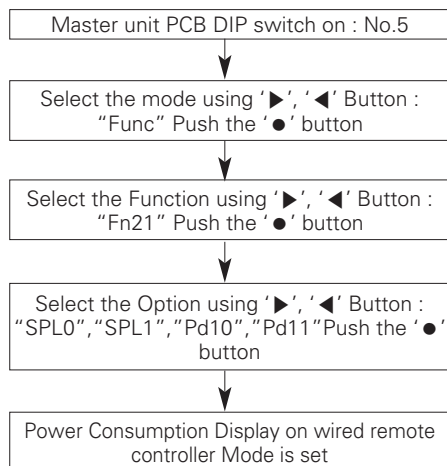

Setting	Detail of function
SPL0	Not used Smart plug logic
SPL1	Using smart plug logic
Pd10	Not installation
Pd11	PDI was installed

Overall Defrost Operating in Low temperature (Heating)

Mode setting method

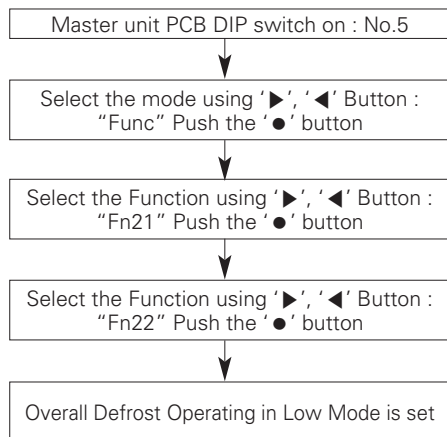

Setting	Detail of function
Default	OFF
Setting	ON/OFF Control

Base pan Heater operation

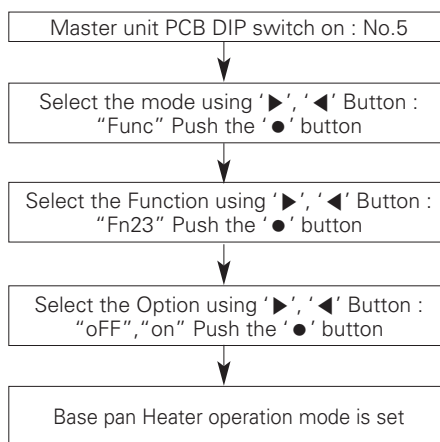

CAUTION

- Function to prevent freezing of ODU base pan in a cold area.
- Heater is accessory.(Sold separately)

Comfort Cooling operation

It is function to reduce the ODU energy consumption by the continuous operation without thermo off.

Mode setting method

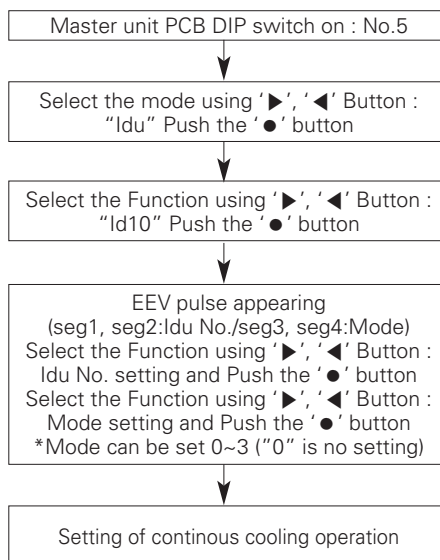

Setting of continous cooling operation

Mode setting	Effect
0	No setting
1	Cooling capacity low,Power consumption low
2	Cooling capacity mid,Power consumption mid
3	Cooling capacity high,Power consumption high

Self-Diagnosis Function

Error Indicator

- This function indicates types of failure in self-diagnosis and occurrence of failure for air condition.
- Error mark is displayed on display window of indoor units and wired remote controller, and 7-segment LED of outdoor unit control board as shown in the table.
- If more than two troubles occur simultaneously, lower number of error code is first displayed.
- After error occurrence, if error is released, error LED is also released simultaneously.

Error Display

1st,2nd,3rd LED of 7-segment indicates error number, 4th LED indicates unit number. (* = 1: Master, 2: Slave 1, 3: Slave 2, 4: Slave 3)

Ex) 1051 : Error occurrence with error number 105 at No. 1 outdoor unit (=Master unit)
 In case of indoor unit error occurrence, the error number is only shown at remote controller without 7 segment LED of outdoor unit.

Ex) CH → 01 : Error occurrence with error number 01 (at remote controller)
 In case of compressor error occurrence, 7 segment LED of outdoor unit control board will display its error number alternately with compressor number.

Ex) 213 → C23 : It means that compressor error occurred with Error No. 21 at No. 3 Outdoor unit (=Slave2)



* Refer to the DX-Ventilation manual for DX-Ventilation error code.

	Display			Title	Cause of Error
Indoor unit related error	0	1	-	Air temperature sensor of indoor unit	Air temperature sensor of indoor unit is open or short
	0	2	-	Inlet pipe temperature sensor of indoor unit	Inlet pipe temperature sensor of indoor unit is open or short
	0	3	-	Communication error : wired remote controller ↔ indoor unit	Failing to receive wired remote controller signal in indoor unit PCB
	0	4	-	Drain pump	Malfunction of drain pump
	0	5	-	Communication error : outdoor unit ↔ indoor unit	Failing to receive outdoor unit signal in indoor unit PCB
	0	6	-	Outlet pipe temperature sensor of indoor unit	Outlet pipe temperature sensor of indoor unit is open or short
	0	8	-	Hydro Kit Hot water storage tank Temperature sensor	Pipe temperature sensor is open or short
	0	9	-	Indoor EEPROM Error	In case when the serial number marked on EEPROM of Indoor unit is 0 or FFFFFF
	1	0	-	Poor fan motor operation	Disconnecting the fan motor connector / Failure of indoor fan motor lock
	1	1	-	Communication error : Hydro Kit Indoor unit ↔ Inv.PCB	Failing to receive Inv. PCB signal in indoor unit
	1	2	-	Hydro Kit Inv.PCB error	Hydro Kit Inv.PCB error
	1	3	-	Hydro Kit Solar heat piping temperature sensor error	Pipe temperature sensor is open or short
	1	4	-	Hydro Kit Indoor unit Flow switch error	Flow switch flow detection error
	1	5	-	Hydro Kit Liquid pipe Strange overheat Error	Temperature sensor defective or hot water inflow
	Outdoor unit related error	2	1	*	Outdoor Unit Inverter Compressor IPM Fault
2		2	*	Inverter PCB Input Over Current(RMS) of Master Outdoor Unit	Outdoor Unit Inverter PCB Input Current excess (RMS)
2		3	*	Outdoor Unit Inverter Compressor DC Link Low or High Voltage	System is turned off by Master Outdoor Unit DC Link Low/High Voltage.
2		4	*	Outdoor Unit High Pressure Switch	System is turned off by Master Outdoor Unit high pressure switch.
2		5	*	Outdoor Unit Input Voltage High/ Low Voltage	Over 537V or below 247V (ARUM***LTE5) Over 310V or below 143V (ARUM***BTE5) Over 598V or below 320V (ARUM***DTE5)

- 1 : Master outdoor unit error, 2 : salve 1 outdoor unit error
- 3 : slave2 outdoor unit error, 4 : slave3 outdoor unit error

Display				Title	Cause of Error
Outdoor unit related error	2	6	*	Outdoor Unit Inverter Compressor Start Failure	The first start failure by Outdoor Unit Inverter Compressor abnormality or Compressor locked
	2	9	*	Outdoor Unit Inverter Compressor Over Current	Outdoor Unit Inverter Compressor Fault OR Drive Fault
	3	2	*	Outdoor Unit Inverter Compressor1 High Discharge Temperature	Outdoor Unit Inverter Compressor1 High Discharge Temperature
	3	3	*	Outdoor Unit Inverter Compressor2 High Discharge Temperature	Outdoor Unit Inverter Compressor2 High Discharge Temperature
	3	4	*	High Pressure of Outdoor Unit	High Pressure of Outdoor Unit
	3	5	*	Low Pressure of Outdoor Unit	Low Pressure of Outdoor Unit
	4	0	*	Outdoor Unit Inverter Compressor CT Sensor Fault	Outdoor Unit Inverter Compressor CT Sensor open or short
	4	1	*	Outdoor Unit Inverter Compressor1 Discharge Temperature Sensor Fault	Outdoor Unit Inverter Compressor Discharge Temperature Sensor open or short
	4	2	*	Outdoor Unit Low Pressure Sensor Fault	Outdoor Unit Low Pressure Sensor open or short
	4	3	*	Outdoor Unit High Pressure Sensor Fault	Outdoor Unit High Pressure Sensor open or short
	4	4	*	Outdoor Unit Air Temperature Sensor Fault	Outdoor Unit Air Temperature Sensor open or short
	4	5	*	Outdoor Unit Heat Exchanger Temperature Sensor (Front side) Fault	Outdoor Unit Heat Exchanger Temperature Sensor(Front side) open or short
	4	6	*	Outdoor Unit Suction Temperature Sensor Fault	Outdoor Unit Suction Temperature Sensor open or short
	4	7	*	Outdoor Unit Inverter Compressor2 Discharge Temperature Sensor Fault	Outdoor Unit Inverter Compressor2 Discharge Temperature Sensor open or short
	4	9	*	Outdoor Unit Faulty IPM Temperature Sensor	Outdoor Unit IPM Temperature Sensor short/open
	5	0	*	Omitting connection of R, S, T power of Outdoor Unit	Omitting connection of outdoor unit
	5	1	*	Excessive capacity of indoor units	Excessive connection of indoor units compared to capacity of Outdoor Unit
	5	2	*	Communication error : inverter PCB → Main PCB	Failing to receive inverter signal at main PCB of Outdoor Unit
	5	3	*	Communication error : indoor unit → Main PCB of Outdoor Unit	Failing to receive indoor unit signal at main PCB of Outdoor Unit.
	5	7	*	Communication error : Main PCB → inverter PCB	Failing to receive signal main PCB at inverter PCB of Outdoor Unit
	6	0	*	Inverter PCB EEPROM Error of Master Outdoor Unit	Access Error of Inverter PCB of Outdoor Unit
	6	2	*	Outdoor Unit Inverter Heatsink High Temperature	System is turned off by Outdoor Unit Inverter Heatsink High Temperature
	6	5	*	Outdoor Unit Inverter Heatsink Temperature Sensor Fault	Outdoor Unit Inverter Heatsink Temperature Sensor open or short
	6	7	*	Outdoor Unit Fan Lock	Restriction of Outdoor Unit
	7	1	*	Inverter CT Sensor Error of Master Outdoor Unit	Inverter CT Sensor open or short of Outdoor Unit
	7	5	*	Outdoor Unit Fan CT Sensor Error	Outdoor Unit Fan CT Sensor open or short
	7	7	*	Outdoor Unit Fan Over Current Error	Outdoor Unit Fan Current is over 6A
	7	9	*	Outdoor Unit Fan Start Failure Error	The first start failure by Outdoor Unit Fan abnormality or Fan locked
	8	6	*	Outdoor Unit Main PCB EEPROM Error	Communication Fail Between Outdoor Unit Main MICOM and EEPROM or omitting EEPROM
	8	7	*	Outdoor Unit Fan PCB EEPROM Error	Communication Fail Between Outdoor Unit Fan MICOM and EEPROM or omitting EEPROM
1	0	4	*	Communication Error Between Outdoor Unit and Other Outdoor Unit	Failing to receive Slave Unit signal at main PCB of Outdoor Unit
1	0	5	*	Outdoor Unit Fan PCB Communication Error	Failing to receive fan signal at main PCB of Outdoor unit
1	0	6	*	Outdoor Unit Fan IPM Fault Error	Instant Over Current at Outdoor Unit Fan IPM

Display					Title	Cause of Error
Outdoor unit related error	1	0	7	*	Outdoor Unit Fan DC Link Low Voltage Error	Outdoor Unit Fan DC Link Input Voltage is under 380V
	1	1	3	*	Outdoor Unit Liquid pipe Temperature Sensor Error	Liquid pipe temperature sensor of Outdoor Unit is open or short
	1	1	4	*	Outdoor Unit Subcooling Inlet Temperature Sensor Error	Outdoor Unit Subcooling Inlet Temperature Sensor Error
	1	1	5	*	Outdoor Unit Subcooling Outlet Temperature Sensor Error	Outdoor Unit Subcooling Outlet Temperature Sensor Error
	1	1	6	*	Outdoor Unit Oil Level Sensor Error	Oil Level Sensor of Outdoor Unit is open or short
	1	4	5	*	Outdoor unit Main Board - External Board communication Error	Outdoor unit Main Board - External Board communication Error
	1	5	0	*	Outdoor Unit Discharge Superheat not satisfied	Outdoor Unit Compressor Discharge Superheat not satisfied during 5 Min.
	1	5	1	*	Failure of operation mode conversion at Outdoor Unit	Failure of operation mode conversion at Outdoor Unit
	1	5	3	*	Outdoor Unit Heat Exchanger Temperature Sensor (upper part) Fault	Outdoor Unit Heat Exchanger Temperature Sensor (upper part) Fault
	1	5	4	*	Outdoor Unit Heat Exchanger Temperature Sensor (lower part) Fault	Outdoor Unit Heat Exchanger Temperature Sensor(lower part) open or short
	1	8	2	*	Outdoor unit External Board Main-Sub Micom communication Error	Outdoor Unit Main Board Main-Sub Micom communication failed
	1	8	7	*	Hydro - Kit P,HEX bursting error	Inlet water temperature is below 5 degree or water temperature error during defrosting operation.
	1	9	3	*	Outdoor Unit Fan Heatsink High Temperature	System is turned off by Outdoor Unit Fan Heatsink High Temperature
	1	9	4	*	Outdoor Unit Fan Heatsink Temperature Sensor Fault	Outdoor Unit Fan Heatsink Temperature Sensor open or short
HR Unit related error	2	0	0	1	Searching pipe Error	Failure of automatic addressing of valves
	2	0	1	C+#HR	HR unit1 Liquid sensor error	Liquid pipe sensor of HR unit open or short
	2	0	2	C+#HR	HR unit1 Sub Cooling Pipe sensor error	Sub Cooling Pipe In sensor of HR unit open or short
	2	0	3	C+#HR	HR unit1 Sub Cooling Pipe Out sensor error	Sub Cooling Pipe Out sensor of HR unit. open or short
	2	0	4	C+#HR	Communication error	Failing to receive HR unit signal at outdoor unit
Network error	2	4	2	*	Network error of cntral controller	Communication wiring defect

C: HR unit

#: HR unit Number

CAUTION FOR REFRIGERANT LEAK

The installer and system specialist shall secure safety against leakage according to local regulations or standards. The following standards may be applicable if local regulations are not available.

Introduction

Though the R410A refrigerant is harmless and incombustible itself, the room to equip the air conditioner should be large to such an extent that the refrigerant gas will not exceed the Concentration limit even if the refrigerant gas leaks in the room.

Concentration limit

Concentration limit is the limit of Freon gas concentration where immediate measures can be taken without hurting human body when refrigerant leaks in the air. The Concentration limit shall be described in the unit of [kg/m³ (lbs/ft³)] (Freon gas weight per unit air volume) for facilitating calculation.

Concentration limit: 0.44 kg/m³ (0.028 lbs/ft³) (R410A)

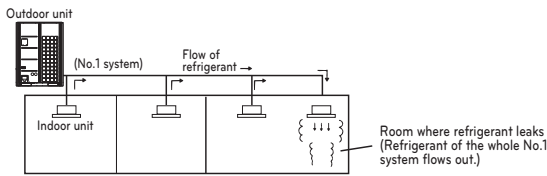

Checking procedure of limiting concentration

Check Concentration limit along following steps and take appropriate measure depending on the situation.

Calculate amount of all the replenished refrigerant [kg (lbs)] per each refrigerant system.

Amount of pre charged refrigerant per single unit system	+	Amount of additional replenished refrigerant	=	Total amount of refrigerant in the system [kg (lbs)]
Amount of replenished refrigerant at factory shipment		Amount of additionally replenished refrigerant depending on piping length or piping diameter by customer		Note : In case one refrigerant facility is divided into 2 or more refrigerant systems and each system is independent, amount of replenished refrigerant of each system shall be adopted.

Calculate refrigerant concentration level

Calculate the volume of the room where indoor unit is installed as single room or the smallest room.

- Without partition
- With partition but opened which serve passage of air to adjoining room

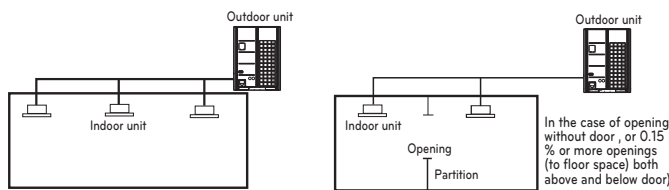

- With partition and without opening which serve as passage of air to adjoining room

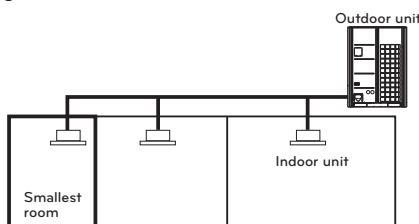

Calculate refrigerant concentration

$$\frac{\text{Total amount of refrigerant system [kg(lbs)]}}{\text{Volume of smallest room where indoor unit is installed [m}^3\text{(ft}^3\text{)]}} = \text{Maximum concentration limit [kg/m}^3\text{ (lbs/ft}^3\text{)] (R410A)}$$

- In case the result of calculation exceeds the Concentration limit, perform the same calculations by shifting to the second smallest, and the third smallest rooms until at last the result is below the Concentration limit.

In case the concentration exceeds the limit

When the concentration exceeds the limit, change original plan or take one of the countermeasures shown below:

- Countermeasure 1
Provide opening for ventilation. Provide 0.15% or More size of opening to floor space both above and below door, or provide opening without door.
- Countermeasure 2
Provide gas leak alarm linked with mechanical ventilator.
- Countermeasure 3
Reducing the system's refrigerant quantity by deviding into smaller separate system.

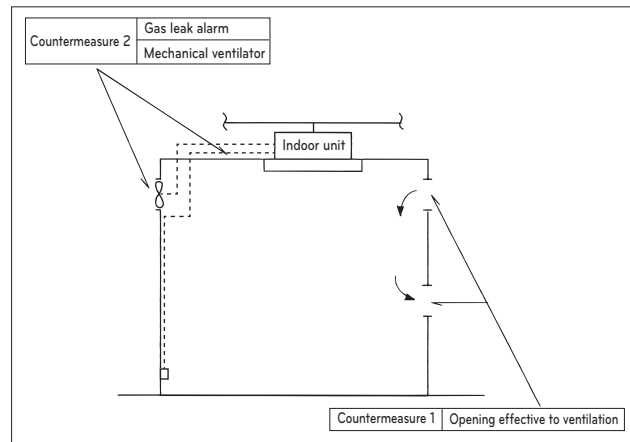

Pay a special attention to the place, such as a basement, etc. where refrigerant can stay, since refrigerant is heavier than air.

INSTALLATION GUIDE AT THE SEASIDE

CAUTION

- Air conditioners should not be installed in areas where corrosive gases, such as acid or alkaline gas, are produced.
- Avoid installing the product where it could be exposed to sea wind (salty wind) directly. It can result corrosion on the product. Corrosion, particularly on the condenser and evaporator fins, could cause product malfunction or inefficient operation.
- If outdoor unit is installed close to the seaside, should avoid direct exposure to the sea wind.

Selecting the location(Outdoor Unit)

If the outdoor unit is to be installed close to the seaside, direct exposure to the sea wind should be avoided. Install the outdoor unit on the opposite side of the sea wind direction.

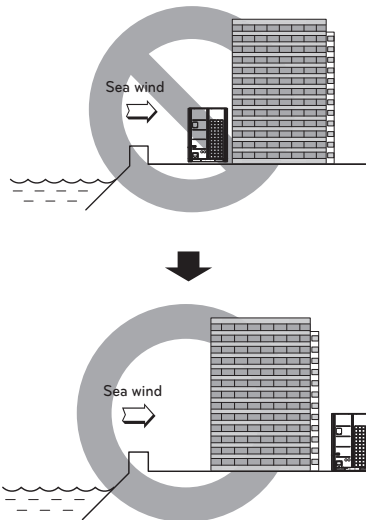

In case, to install the outdoor unit on the seaside, set up a windbreak not to be exposed to the sea wind.

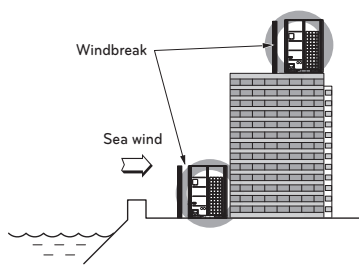

- It should be strong enough like concrete to prevent the sea wind from the sea.
- The height and width should be more than 150% of the outdoor unit.
- It should be kept more than 70 cm (2.3 ft) of distance between outdoor unit and the windbreak for smooth air flow.

Select a well-drained place.

- Periodic (1times per 6 month) cleaning of the dust or salt particles stuck on the heat exchanger is necessary by using clean water

If there is improper installation or maintenance not complying with the installation guide, product's performance and reliability is not guaranteed.

Model Designation

Product information

- Product Name : Air conditioner
- Model Name :

Product Sales Name	Model Factory Name
ARUx***BTy5 series	
x = N (Heat Pump), V (Cooling Only), M (Heat Recovery / Heat Pump)	
y = S (Basic function), E (Additional function related to performance)	
*** = Numeric; (Cooling capacity)	

- Additional information : Serial number is refer to the bar code on the product.

Airborne Noise Emission

The A-weighted sound pressure emitted by this product is below 70 dB.

** The noise level can vary depending on the site.

The figures quoted are emission level and are not necessarily safe working levels.

Whilst there is a correlation between the emission and exposure levels, this cannot be used reliably to determine whether or not further precautions are required.

Factor that influence the actual level of exposure of the workforce include the characteristics of the work room and the other sources of noise, i.e. the number of equipment and other adjacent processes and the length of time for which an operator exposed to the noise. Also, the permissible exposure level can vary from country to country.

This information, however, will enable the user of the equipment to make a better evaluation of the hazard and risk.



MEMO

ENGLISH





ENGLISH

MEMO





1. Não é recomendável o descarte de pilhas, baterias em lixo comum. Após o uso, estes itens devem ser descartados de forma adequada, sob pena de ocasionarem danos ao meio ambiente e à saúde humana.
2. A LG criou o Programa Coleta Inteligente, para facilitar e viabilizar o descarte adequado de aparelhos celulares, pilhas e baterias.
3. Através do Programa Coleta Inteligente, a LG disponibiliza pontos de coleta em localidades diversas, incluindo assistências técnicas autorizadas da LG Electronics. Para mais informações visite o site www.lge.com/br/coleta-seletiva ou contate nosso SAC através do número 4004-5400 (Capitais e Regiões metropolitanas) ou 0800-707-5454 (demais localidades).