



Scan the QR code to see the manual.



OWNER'S MANUAL

DEHUMIDIFIER



Before beginning installation, read these instructions carefully. This will simplify installation and ensure that the product is installed correctly and safely. Leave these instructions near the product after installation for future reference.

ENGLISH

MD19GQGE0

TABLE OF CONTENTS

This manual may contain images or content that may be different from the model you purchased.
This manual is subject to revision by the manufacturer.

SAFETY INSTRUCTIONS

READ AND SAVE THESE INSTRUCTIONS 3
WARNING INSTRUCTIONS 3
CAUTION INSTRUCTIONS 7

OPERATION

Product Overviews 9
Preparation before Operation 12
Examining Features 13
Operating the dehumidifier 15
Using the Extra Functions 17
Emptying Water Tank 19

SMART FUNCTIONS

LG ThinQ Application 23
Smart Diagnosis 24

MAINTENANCE

Maintaining the Product 26

TROUBLESHOOTING

Before Calling for Service 29

APPENDIX

Information 32

SAFETY INSTRUCTIONS

READ AND SAVE THESE INSTRUCTIONS

The following safety guidelines are intended to prevent unforeseen risks or damage from unsafe or incorrect operation of the appliance. The guidelines are separated into 'WARNING' and 'CAUTION' as described below.

Safety Messages



This symbol is displayed to indicate matters and operations that can cause risk.

Read the part with this symbol carefully and follow the instructions in order to avoid risk.



WARNING

This indicates that failure to follow the instructions can cause serious injury or death.



CAUTION

This indicates that failure to follow the instructions can cause minor injury or damage to the product.

WARNING INSTRUCTIONS

WARNING

- To reduce the risk of explosion, fire, death, electric shock, injury or scalding to persons when using this product, follow basic precautions, including the following:

Technical Safety

- This appliance is not intended for use by persons (including children) with reduced physical, sensory or mental capabilities or lack of experience and knowledge, unless they have been given supervision or instruction concerning use of the appliance by a person

responsible for their safety. Children should be supervised to ensure that they do not play with the appliance.

- If the supply cord is damaged, it must be replaced by the manufacturer, its service agent or similarly qualified person in order to avoid a hazard.
- Only an authorized repair person should disassemble, repair, or modify the appliance.
- Do not touch the power plug with wet hands.
- Do not place the power cord under rugs, carpeting or mats.

Installation

- Do not install the appliance on an uneven or inclined surface.
- Do not install the appliance in an area exposed to direct sunlight or near heat-generating equipment.
- Do not install the product in a place where combustible gas may leak or industrial oil or metallic particulates are present.
- Do not allow the appliance to push against the power cord or plug.
- Do not bend the power cable excessively or place a heavy object on top of it.
- Do not extend the length of the power cable or alter it.
- Do not use several devices on a multi-socket extension outlet.
- Do not use the product if the outlet is damaged or loose.
- Make the connection securely so that screw in terminals may not be loosened when the cable is pulled.
- Make sure that the power cable cannot be pulled out or damaged during operation.
- When unplugging the power cord, always pull it by the plug.
- Unplug the appliance during thunder or lightning storms or when not in use for a long time.

Operation

- If the appliance is immersed in water, stop using it and contact an LG Electronics Customer Information Center.
- If there is a gas leakage (isobutane, propane, LNG, etc.), do not touch the appliance or power plug and ventilate the area immediately.
- If you detect any abnormal noise, odor or smoke, unplug the appliance immediately and contact an LG Electronics Customer Information Center.
- Do not clean the appliance with brushes, cloths or sponges which are abrasive or made of metal.
- Do not use or store fire, combustibles (ether, benzene, alcohol, drugs, propane, butane, combustible spray, insecticide, air freshener, cosmetics, etc.) or flammable materials (candles, lamps, etc.) near the product.
- Do not allow animals or pets to chew on the power cord.
- Do not move the appliance when it is in operation.
- Do not hit the appliance.
- Do not insert hands or metal objects into the air inlet or outlet.
- Do not put flammables into the appliance.
- Do not allow children to climb on or play with the appliance.
- Do not place anything on top of the appliance.
- Do not place combustion appliances directly in the path of the dehumidifier's airway.
- Do not use the product in places where it could be splashed by water.
- Do not use the product in direct sunlight or rain.

UVnano Function

NOTE

- UVnano is a compound word of UV (ultraviolet rays) and nanometer (length unit).
-

- This product uses UVnano LED. Do not disconnect or replace the UVnano LED arbitrarily. LEDs must be replaced only by LG-approved service providers.
- Harmful UVnano radiation may leak if the device is used in an unintended way or if the wires are damaged. UVnano radiation, even in very small amounts, can harm the eyes and skin.
- The UVnano LED is not a part that needs cleaning, so do not clean the UVnano LED or parts with the UV hazard label separately.
- If the UVnano LED is damaged, do not operate it.
- This appliance contains a UV emitter. Do not stare at the light source.
- Do not operate UVnano LED outside of the appliance.
- Read the maintenance instructions before opening the appliance.
- The appliance must be disconnected from the supply before replacing the UV-C emitter.

Maintenance

- Dispose of the packing materials (vinyl, styrofoam, etc.) to keep them out of reach of children.
- Take care not to injure or pinch yourself when you detach and reattach parts of the appliance.
- Turn off and unplug the appliance before cleaning it or replacing the filter.
- Do not use water to clean the dehumidifier.

CAUTION INSTRUCTIONS

CAUTION

- To reduce the risk of minor injury to persons, malfunction, or damage to the product or property when using this product, follow basic precautions, including the following:

Installation

- Do not tilt the appliance to pull or push it when transporting.
- Do not install the appliance in a vehicle, RV, or marine vessel.
- Do not place the appliance near a TV or stereo equipment.
- Do not place the appliance under bright light.
- Do not place vases or water jars on the dehumidifier.
- The appliance must be installed in accordance with national wiring regulations.
- When moving or storing the appliance, wrap the power cord around the base of the appliance to prevent personal injury, damage to the cord or damage to floors.
- Do not place the appliance near curtains.
- Do not use excessive force when pulling the extension hose.

Operation

- Do not use the product for removal of toxic gas such as carbon monoxide.
- Do not use the appliance for a long time in a region with unstable voltage.
- Do not place obstacles around the air inlet or outlet.
- For safe use of the appliance, children or others with reduced mental capabilities need to be closely monitored by a person who is responsible for their safety.
- Do not use the product for special purposes such as preserving plants, precision instruments, artworks, etc.

- Do not operate the appliance with wet hands.
- Do not use the appliance while it is not in an upright position.
- Do not use the appliance near objects vulnerable to heat.
- Do not use detergents, cosmetics, chemicals, air fresheners, or disinfectants in the appliance.
- Do not touch any internal parts while the unit is operating or immediately after operation.
- Do not insert any objects into the Air outlet.
- Do not use the product in places where chemicals are used.
- Do not operate the dehumidifier without a filter.
- Turn off the dehumidifier and empty the water tank before moving the dehumidifier.
- Pull out the power plug if you will not be using the product for an extended period.
- Do not use the product in a very small space such as a closet.
- Do not keep the power cord tied up when using the product.
- Do not spray foreign substances or water into the sensor hole.
- Do not allow children to mount on the product.

Maintenance

- Do not use strong detergents or solvents to clean the appliance. Use a soft cloth to clean.
- Do not clean the appliance with an alkaline detergent.
- Do not wipe the appliance surface using sulfuric acid, hydrochloric acid or organic solvents (thinner, kerosene etc.) or attach a sticker on the appliance.
- Turn off the dehumidifier and pull out the power plug before cleaning.
- Do not allow water inside the appliance.
- Do not wash the filter with water.

OPERATION

- The exterior or components of the product may vary depending on the model.

Product Overviews

Front

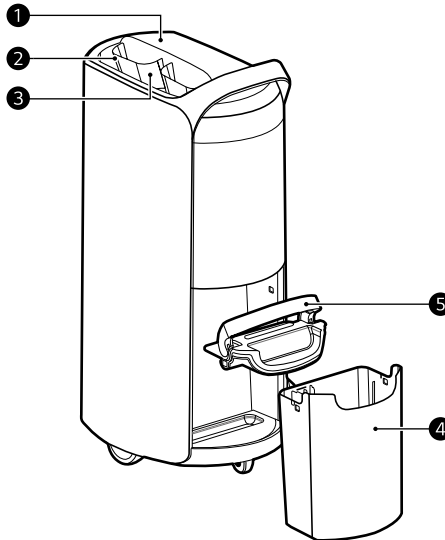

1 Control Panel/Status Display

- Use it to set the appliance functions.
- Use it to check the settings of the appliance.

2 Air Outlet

- Dehumidified air is emitted.

3 Louver

- It adjusts the direction of the wind.

4 Water Tank

- It stores dehumidified water.

5 Water Tank Lid

Back

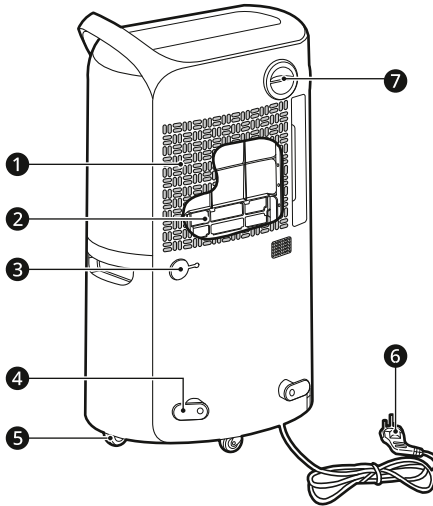

1 Air Inlet

- It absorbs the air and moisture in the room.

2 Pre-Filter

3 Rubber Cap

4 Power Plug Hanging Part

5 Wheels

6 Power Plug

7 Hose Cover

Components

- The components are at the top part of the product packaging box.
- The form of water tank may differ in each product



1

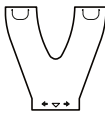

2

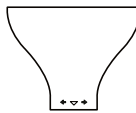

3

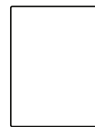

4

1 Extension Hose

2 Shoes Drying Kit

3 Laundry Drying Kit

4 Quick Guide

Preparation before Operation

Checklist Before Usage

- Dehumidification amount changes according to indoor temperature and relative humidity.
 - If the temperature or relative humidity is low, dehumidification amount is decreased.
 - Dehumidification is performed with compressor operation only when the desired humidity is lower than the current humidity.
- The product can operate in the temperature boundary of 5 °C ~ 32 °C.
 - At 0 °C or less, dehumidified water will freeze, and dehumidification can not be performed.
 - If it is over 32 °C, the temperature inside the dehumidifier will rise, and there will be cases of stopping the operation by protective device activation to avoid excessive usage.
- When the dehumidifier is under operation, the indoor temperature will rise.
 - Dehumidifier does not have a cooling/heating function.
 - Heat is generated during the operation, so the temperature may be increased by about 2 °C ~ 3 °C according to the usage conditions (indoor temperature, size of the room).
- Operation will restart after 3 minutes.
 - If it is restarted right after the stop, the compressor will start about 3 minutes after to protect the product.
- It automatically protects the product during the continuous operation.
 - If it is operated for 24 hours or more continuously, the compressor will stop automatically to protect the product, and it will restart after 1 hour.
- There may be water remaining in the drain water tank at the first time usage.
 - There may be water remaining in the drain water tank by the product outgoing inspection to check the normal operation of the product. It is not a failure.

Installation Location Requirements

Install the product at least 30 cm from walls.

- If it is not ventilated well, the air suction performance will be degraded.

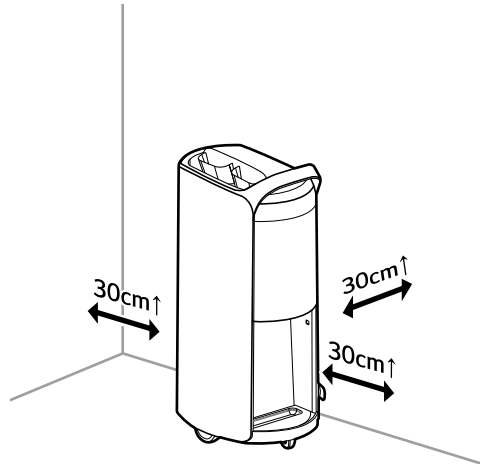

Examining Features

Controlling the Dehumidifier

Control Panel

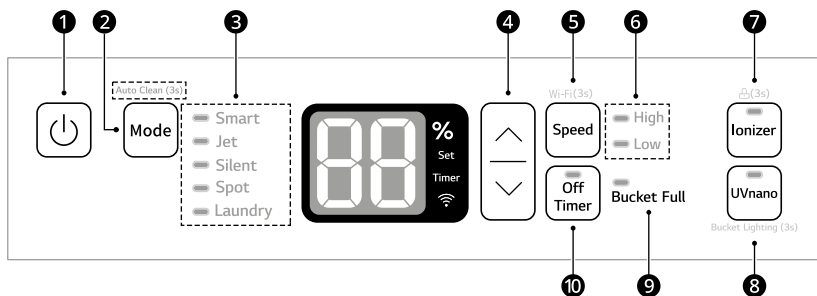

1 Start/Stop Button

- Use it to turn the product on or off.

2 Mode Button

- Use it to set the mode.
- When you press and hold the button for 3 seconds, the **Auto Clean** function will turn on/off.

3 Operation Mode Lamp

- It displays the currently set operation mode.

4 Humidity Control Button

- It controls the desired humidity. (30 % ~ 70 %)
- Humidity control can be set in the units of 5 %.

5 Speed Button

- Use it to set the fan speed.
- When you press and hold the button for 3 seconds, the product will be ready to connect to Wi-Fi, and you can connect to Wi-Fi through the **LG ThinQ** Application.
- Wi-Fi function off: Press and hold the **Start/Stop** button and the **Speed** button simultaneously for 3 seconds or more.

6 Speed Indicator Lamp

- It displays the currently set speed.

7 Ionizer Button

- It is used to remove harmful bacteria in the air.
- When you press the button for 3 seconds, lock function is operated.

8 UVnano Button

- It is used to keep the fan clean.
- When you press and hold the button for 3 seconds, LED light of the bucket will turn on/off.

9 Bucket Full Indicator Lamp

14 OPERATION

- When the water tank is full, the light comes on.

10 Off Timer Button

- The product will be turned off after the set time.
- When the button is pressed, it is increased by 1 hour each time and you can set up to 8 hours.

Status Display

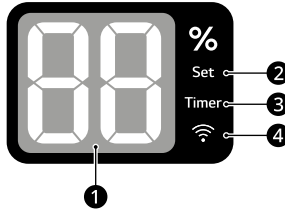

1 Humidity/Off Timer Display

- It displays the current humidity and desired humidity. When Off timer is set, it displays the Off timer time and it automatically displays the current humidity after completing the setting.

2 Set Indicator Lamp

- It is displayed when humidity is set.
- Desired humidity is displayed with Set light and the light is turned off when showing current humidity.

3 Timer Indicator Lamp

- It is displayed when timer is set in **LG ThinQ** app.

4 Wi-Fi Indicator Lamp

- It is displayed when Wi-Fi function is set.

Operating the dehumidifier

Start/Stop

Press the **Start/Stop** button to turn on or off the dehumidifier.



NOTE

- If the product started again right after stopping the operation, dehumidification operation does not start for about 3 minutes to protect the compressor.

Operating Mode

Press the **Mode** button to select the mode.

- If you press the **Mode** button during operation, the mode will change in the order of **Smart** → **Jet** → **Silent** → **Spot** → **Laundry**.

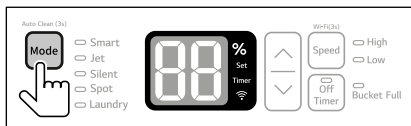

Smart Dehumidification

When you want to maintain pleasant indoor condition.

- Press **Mode** button to select **Smart** Dehumidification mode.

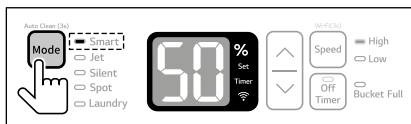

NOTE

- If you set the desired humidity, it maintains the humidity set by the user.

- Once the humidity level reaches the desired humidity, the compressor stops and only the fan operates. If relative humidity goes up, it will operate dehumidification again.
- The Speed is set to high as default and you can set speed and desired humidity.

Jet Dehumidification

When you want to remove indoor moisture quickly.

- Press **Mode** button to select **Jet** Dehumidification mode.

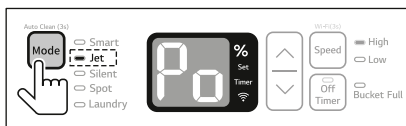

NOTE

- Under **Jet** Dehumidification mode, it will change to **Smart** Dehumidification mode after 60 minutes.

Even if it is under power wind (P0) operation, high wind indicator lamp is lighted.

- When it is in **Jet** Dehumidification mode, if you select **Humidity control** button or **Speed** button, it switches to **Smart** Dehumidification.
- If it changes from **Smart/Silent** Dehumidification to **Jet** Dehumidification, the desired humidity selected in another operation mode is set.

Silent Dehumidification

When you want dehumidification in silent mode.

Silent dehumidification operation makes silent and pleasant room even during the night.

- Press **Mode** Button to select **Silent** Dehumidification mode.

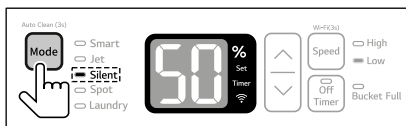

NOTE

- The Speed is set to low as default and you can set speed and desired humidity.

Spot Dehumidification

When you need spot drying of shoes, closet, etc.

- Press **Mode** Button to select **Spot** Dehumidification mode.

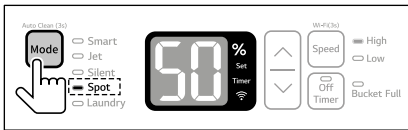

NOTE

- In **Spot** Dehumidification mode, the louver is closed.
- The speed is set to high and humidity control/speed is not operational.
- The current humidity is displayed in the status display.
- Use the product by connecting shoes drying/laundry drying kit through the extension hose as necessary.

How to use Spot Dehumidification

※ The form of water tank may differ in each product.

- 1 Open the hose cover at the back of the product by turning it counterclockwise.

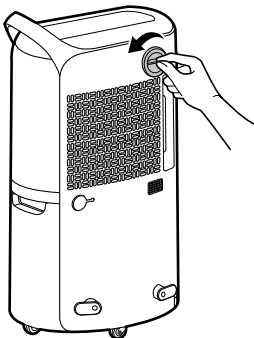

- 2 After inserting extension hose, fix it by turning it clockwise.

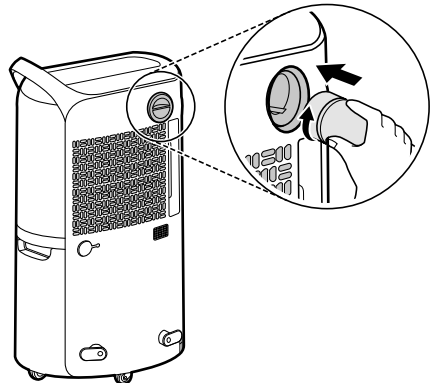

- 3 Connect shoes drying kit or laundry drying kit to the extension hose.

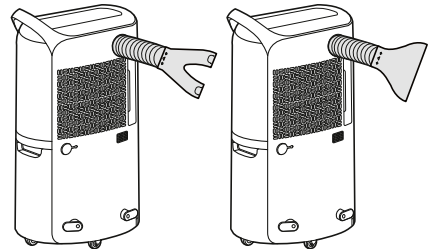

- 4 Extend the hose to make it face the desired drying direction.

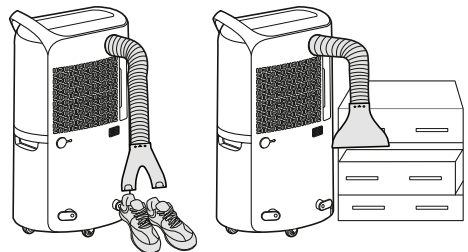

⚠ CAUTION

- Do not move the dehumidifier by holding the extension hose.

- If **Spot** Dehumidification is used for long period of time, the operation may stop to protect the product.

Laundry Dehumidification

When you want to dry laundry continuously regardless of the ambient humidity.

- Press **Mode** Button to select **Laundry** Dehumidification mode.

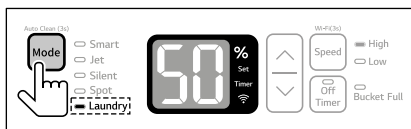

CAUTION

- When drying laundry, be careful not to have laundry water drop on to the dehumidifier.

NOTE

- The speed is set to high at default and you can change the speed. But you can't set desired humidity.
- Louver operates up and down.

Adjusting the Humidity

- Press the **Humidity Control** \wedge / \vee button during operation to change humidity.
- If you press the **Humidity Control** button, the desired humidity will change in the order of 30 \leftrightarrow 35 \leftrightarrow 40 \leftrightarrow 45 \leftrightarrow 50 \leftrightarrow 55 \leftrightarrow 60 \leftrightarrow 65 \leftrightarrow 70.

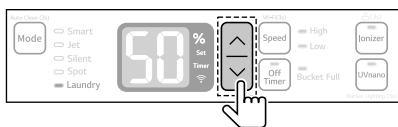

NOTE

- Humidity can be set with the units of 5 %.

- During the humidity setting, desired humidity is displayed on the status display and the current humidity is displayed after about 5 seconds.
- Current humidity is displayed in the units of 5 % from 25 % ~ 90 %.

If it is less than 25 %, it is displayed as 25 % and if it is 90 % or more, it is displayed as 90 %.

Adjusting the Fan Speed

- Press the **Speed** button during operation to control the fan speed of the dehumidifier.
- If you press the **Speed** button, the speed will change in the order of High \leftrightarrow low.

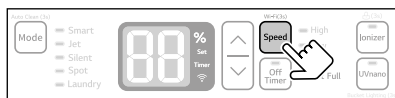

Using the Extra Functions

Auto Clean

This function dries inside of the dehumidifier in order to prevent mold or germs.

- Press the **Mode** button for 3 seconds during operation to set up **Auto Clean**.
- Each time the **Mode** button is pressed for 3 seconds : **Auto Clean** \rightarrow Setting cancellation - then it repeats.
- When running **Auto Clean**, $\square\square$ is displayed on the status display.



NOTE

- After **Auto Clean** function finishes, the LED display automatically turns off.
- When the operation stops, the **Auto Clean** will start.

NOTE

- When **Auto Clean** function starts, the dehumidifier will run the fan for a certain period in order to remove moisture inside the product.

Timer Function

Various kinds of reservation including the power on/off can be made by the **LG ThinQ** application.

- When Timer Function is set through **LG ThinQ** application, the timer set indicator lamp is lighted.

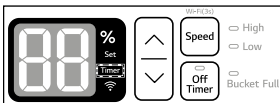

NOTE

- For more detailed description on the use of **LG ThinQ**, refer to **Smart Functions** section.
- You can set the timer time through **LG ThinQ** application.
- You can set the timer function only through **LG ThinQ** application.

Defrost Operation

If there is frost in the heat exchanger due to low indoor temperature, it automatically removes the frost.

- During the operation, if **dF** is displayed on the status display, it automatically runs the defrost in the heat exchanger inside the product.

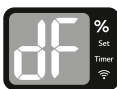

NOTE

- Compressor is stopped during the automatic defrost operation.

Off Timer

- Press the **Off Timer** button during operation to select the setting time.
- Each time you press the **Off Timer** button, the set timer changes in the following order : 1 → 2 → ... → 8 → Cancel.



NOTE

- The remaining time is displayed as time goes.
- When it passes the selected time, operation stops.

To cancel Off Timer

If you press **Off Timer** button repeatedly until the time display disappears in the status display, it will be cancelled.

NOTE

- Drain the water inside the water tank and then set the time.
- If water tank becomes full during Off Timer operation, Bucket Full indicator lamp is lighted and the dehumidification stops.

Ionizer Function

When you want to remove harmful bacteria in the air.

- Press the **Ionizer** button during operation to use Ionizer Function.

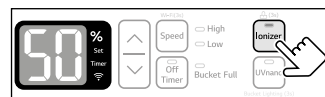

NOTE

- It removes harmful material in the air such as bacteria, virus, etc. using ionized air.

- You can use Ionizer function and dehumidification function at the same time.
- Ionizer can be used at any time regardless of dehumidifier function.

Lock Function

You can lock the buttons on the control panel to prevent the appliance from operating due to unforeseen reasons, such as a child manipulating the buttons.

- Press the **Ionizer** button for 3 seconds during operation to set Lock/Unlock Function.
- [L] display in the status display is maintained for 5 seconds.

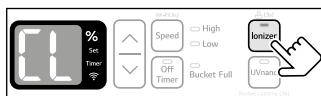

NOTE

- If you take off your hand when the buzzer sounds 1 time after 3 seconds, it enters Lock Function.
- It maintains the operation state at the time of setting the function until the function is turned off and there will be no response even if a button is pressed.
- If you press other buttons in Lock Function set state, warning sound is generated 3 times and [L] display is displayed in the status display for 5 seconds.
- You can set the function regardless of whether the product is in operation.

Using UVnano

This feature reduces various bacteria in the dehumidifier.

- Press the **UVnano** button during operation.

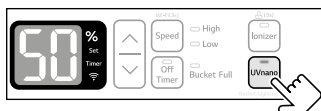

NOTE

- UVnano is a compound word of "UV" LEDs that reduce harmful bacteria and "nanometers", as in the ultraviolet wavelength unit.
- The UV LED operates regularly to keep the fan clean.
- The UVnano function stops when the dehumidifier is turned off.

Bucket Lighting Function

- If you want to use Bucket Lighting Function, press the **UVnano** button for 3 seconds.

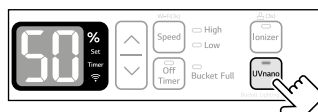

Emptying Water Tank

Bucket Full

When the water tank is full, operation automatically stops, bucket full lamp is lighted and warning buzzer sounds. (Warning buzzer will sound one more time after 1 minutes.)

- When the full water is detected, the dehumidification function immediately stops and fan operates for 5 minutes to remove the remaining condensed water.
- Bucket Full lamp is lighted on the status panel and the product operation stops.

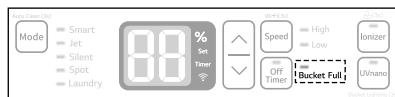

- After draining, when you insert water tank again, bucket full lamp is turned off and operation starts again automatically.

⚠ CAUTION

- Carefully take out the drain water tank.



- If you pull the water tank too hard, the water inside may spill over.
- when you take out the water tank, make sure to stop the product.
- If you take out the water tank during the operation, compressor will stop and fan will operate for 5 minutes to vaporize the remaining condensed water in the heat exchanger before stopping the operation.
- Lamp will turn on if water tank in not correctly placed. Check if water tank fully and correctly placed.
- When you move the product or shock is imposed to the product, Bucket full lamp may be lighted.
- Drain the water inside the water tank and reassemble the water tank.

How to empty water tank

- 1 Hold the top handle of the water tank and softly take it out.

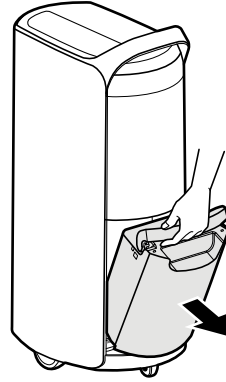

- 2 Open the drain lid of the water tank.

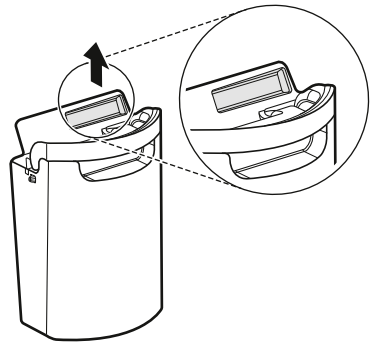

- 3 Pour out the water inside the water tank.

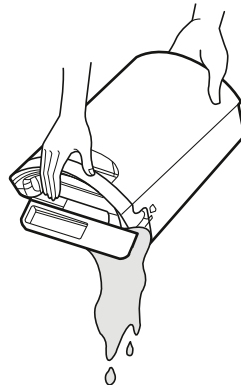

- 4 First insert the bottom part of the water tank correctly into the hole and then push it in.

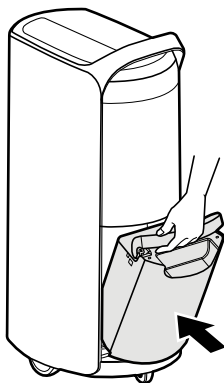

NOTE

- If the water tank is taken out right after stopping the operation, there are cases of water remaining in the heat exchanger dropping into the main unit. (Wipe the dropped water with soft cloth.)
- After taking out the water tank, do not touch inside the main unit. it will cause failure of the full water detection device.
- Periodically clean inside the water tank. (about 1 time per week).
- If it is used during winter or at low temperature, there is less moisture in the air, so dehumidification amount is also decreased.
- When you take out the water tank, make sure to stop the product. If you take out during operation, the compressor will stop and the fan operates for 5 minutes to vaporize the remaining condensed water inside the heat exchanger before complete stop.

How to continuous drainage setup

- 1 Hold the top handle of the water tank and softly take it out.

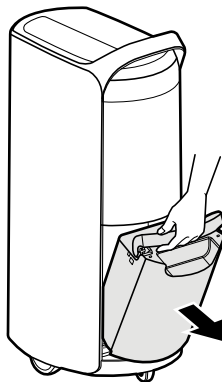

- 2 Then open the rubber cap connected to the continuous drain at the back of the product.

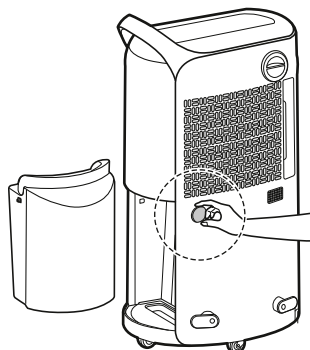

22 OPERATION

- 3 Insert the continuous drainage hose(1) into the continuous drainage hole and connect it to the drain hole on the product.

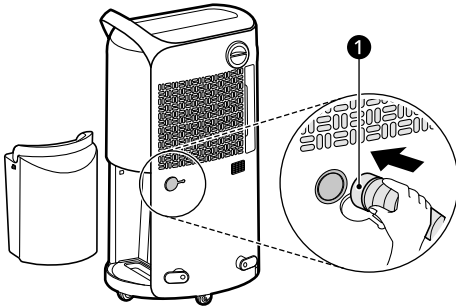

- 4 First insert the bottom part of the water tank correctly into the hole and then push it in.
- If the water bucket is not inserted, the product will not operate.

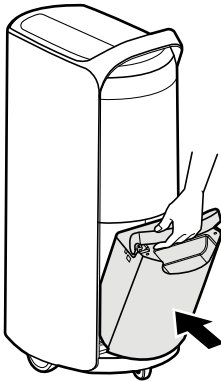

NOTE

- The continuous drainage hose is sold separately. If you wish to use a commercial hose available in the market, use a hose whose internal diameter is 16mm.
- Check if the continuous drainage hose is connected to the drain hole on the product correctly. If the continuous drainage hose is not connected to the drain hole on the product correctly, water may leak when dehumidification is carried out.
- How to connect the hose for continuous drainage
 - Do not bend the continuous drainage hose or soak it in water.
 - Keep a distance of at least 10cm from the drain.

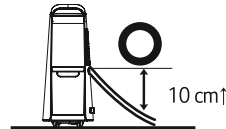

⚠ CAUTION

- Be careful of the cut part around the continuous drainage hole when connecting or separating the continuous drainage hose. The cut part is sharp and it may cause injury.
- Take care not to injure hands while connecting drainage hose.
- The product does not work without the water bucket installed.

SMART FUNCTIONS

LG ThinQ Application

The **LG ThinQ** application allows you to communicate with the appliance using a smartphone.

LG ThinQ Application Features

Smart Diagnosis

If you experience a problem while using the appliance, this **Smart Diagnosis** feature will help you diagnose the problem.

Settings

Allows you to set various options on the appliance and in the application.

NOTE

- In the following cases, you must update the network information for each appliance in the **LG ThinQ** application under **Device Cards** → **Settings** → **Change Network**.
 - wireless router is changed
 - wireless router password is changed
 - Internet service provider is changed
- The application is subject to change for appliance improvement purposes without notice to users.
- Functions may vary by model.

Before Using LG ThinQ Application

This feature is only available on models with Wi-Fi function.

- 1 Check the distance between the appliance and the wireless router (Wi-Fi network).
 - If the distance between the appliance and the wireless router is too far, the signal strength becomes weak. It may take a long time to connect or installation may fail.

- 2 Turn off the Mobile data or Cellular Data on your smartphone.

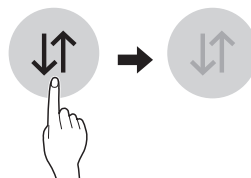

- 3 Connect your smartphone to the wireless router.

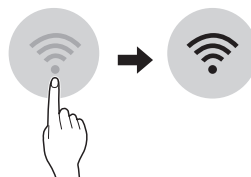

NOTE

- To verify the Wi-Fi connection, check that the Wi-Fi  icon on the status display is lit.
- **The appliance supports 2.4 GHz Wi-Fi networks only.** To check your network frequency, contact your Internet service provider or refer to your wireless router manual.
- **LG ThinQ** is not responsible for any network connection problems or any faults, malfunctions, or errors caused by network connection.
- If the appliance is having trouble connecting to the Wi-Fi network, it may be too far from the router. Purchase a Wi-Fi repeater (range extender) to improve the Wi-Fi signal strength.
- The Wi-Fi connection may not connect or may be interrupted because of the home network environment.
- The network connection may not work properly depending on the Internet service provider.
- The surrounding wireless environment can make the wireless network service run slowly.

NOTE

- If the appliance cannot be connected due to problems with the wireless signal transmission, unplug the appliance and wait about a minute before trying it again.
- If the firewall on your wireless router is enabled, disable the firewall or add an exception to it.
- The wireless network name (SSID) should be a combination of English letters and numbers. (Do not use special characters.)
- Smartphone user interface (UI) may vary depending on the mobile operating system (OS) and the manufacturer.
- If the security protocol of the router is set to WEP, the network setup may fail. Change the security protocol (WPA2 is recommended) and connect the product again.

Installing the LG ThinQ Application

Search for the **LG ThinQ** application from the Google Play Store or Apple App Store on a smartphone. Follow instructions to download and install the application.

Open Source Software Notice Information

To obtain the source code that is contained in this product, under GPL, LGPL, MPL, and other open source licenses that have the obligation to disclose source code, and to access all referred license terms, copyright notices and other relevant documents, please visit <https://opensource.lge.com>.

LG Electronics will also provide open source code to you on CD-ROM for a charge covering the cost of performing such distribution (such as the cost of media, shipping, and handling) upon email request to opensource@lge.com.

This offer is valid to anyone in receipt of this information for a period of three years after our last shipment of this product.

Smart Diagnosis

Use this feature to help you diagnose and solve problems with your appliance.

NOTE

- For reasons not attributable to LGE's negligence, the service may not operate due to external factors such as, but not limited to, Wi-Fi unavailability, Wi-Fi disconnection, local app store policy, or app unavailability.
- The feature may be subject to change without prior notice and may have a different form depending on where you are located.

Using LG ThinQ to Diagnose Issues

If you experience a problem with your Wi-Fi equipped appliance, it can transmit troubleshooting data to a smartphone using the **LG ThinQ** application.

- Launch the **LG ThinQ** application and select the **Smart Diagnosis** feature in the menu. Follow the instructions provided in the **LG ThinQ** application.

Using Audible Diagnosis to Diagnose Issues

Follow the instructions below to use the audible diagnosis method.

- Launch the **LG ThinQ** application and select the **Smart Diagnosis** feature in the menu. Follow the instructions for audible diagnosis provided in the **LG ThinQ** application.

- 1 Press and hold the **Off Timer** button for 5 seconds to execute the **Smart Diagnosis** function.

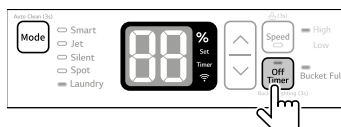

- 2 Place your smartphone near the product.
- Make sure the microphone of the smartphone faces the front of the product.

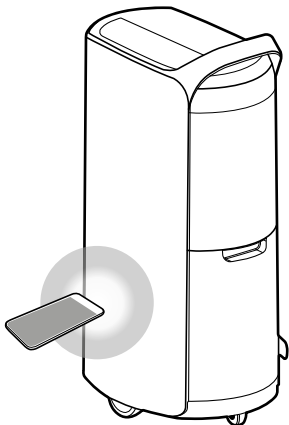

- 3 When data transmission is complete, the **Smart Diagnosis** result will be displayed on the **LG ThinQ** Application.

NOTE

- For accurate diagnosis, do not move the smartphone away from the product until the beeping stops.
- Keep quiet around the product during **Smart Diagnosis**.

MAINTENANCE

Maintaining the Product

Cleaning the exterior

- 1 Remove dust using a vacuum cleaner.

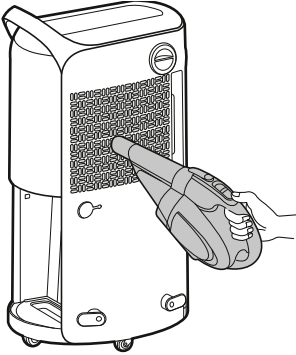

- 2 Wipe the air inlet and the exterior of the product with a soft cloth.

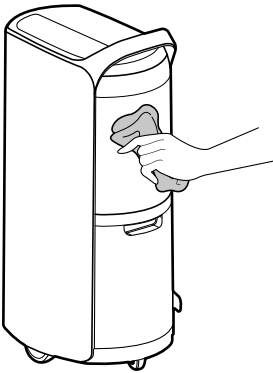

⚠ CAUTION

- Do not wipe the appliance with an alkaline detergent.
- Never use sulphuric acid, hydrochloric acid or organic solvent (e.g., thinner, kerosene and acetone) to wipe the appliance exterior, or affix labels on the exterior. Doing so may damage the product surface.

- Care should be exercised to prevent flowing of water into the product.

Cleaning the water tank

- 1 Press the fixing part on both sides of the water tank to take out the lid.

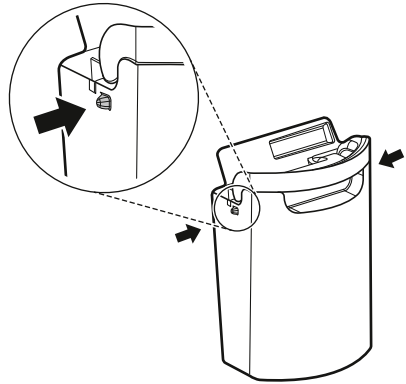

- 2 Wipe the water inside the water tank.
 - Do not open the lid because there is a float (1) to detect full water inside.

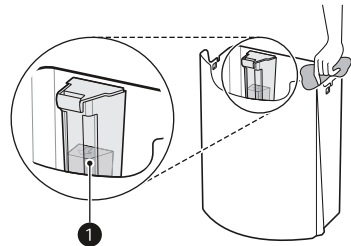

NOTE

- If the float is fallen off or assembled incorrectly, there may be water leakage.
- Do not use hot water, detergent, air fresheners, surfactants, antistatic agents, etc. It may damage the exterior of the product.

Cleaning the Filters

- 1 Push the Pre-Filter to the right to take it out.

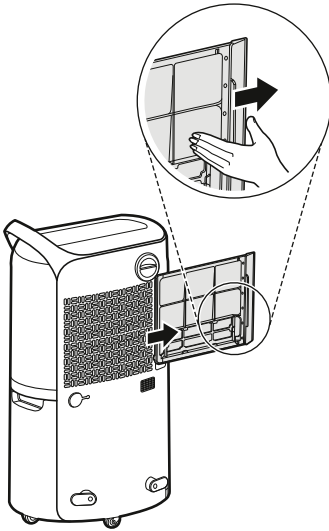

- 2 Clean the Pre-Filter with vacuum cleaner or soft brush.

- If the contamination is severe, wash with water using neutral detergent. (Do not use hot water of 40 °C or higher.)
- The cleaning period for Pre-Filter is 1 month.

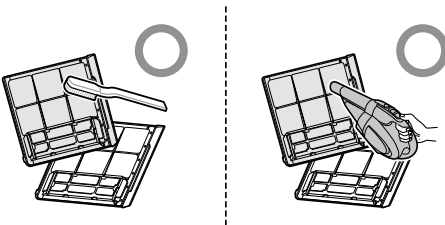

- 3 Completely dry in shade and push to the left until the Pre-Filter is not pushed anymore.

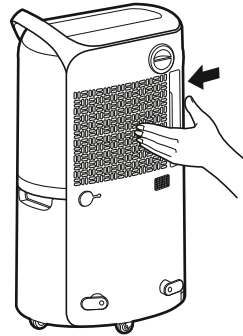

⚠ CAUTION

- For the safety, pull out the power plug before cleaning.
- Be careful not to damage the Pre-Filter when using a vacuum cleaner.
- After washing the Pre-Filter with water, completely dry it in shadow.

Storage

Storing the Product

If the product will not be used for a long period of time, store it in a dry and shaded place.

- 1 Turn off the power and unplug it from the electrical outlet.
 - Wind the power cord around the bottom of the appliance.
- 2 Completely drain the water remaining inside the water tank.
 - Separate the water tank lid and wipe the water inside the water tank.
- 3 Clean the filter.

- 4 Package the appliance to prevent the dust or foreign substance from entering the appliance. Store the packaged appliance at a shaded place.

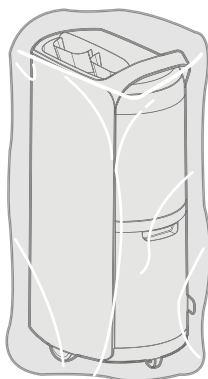

⚠ CAUTION

- Do not store the appliance at a humid place or at a place exposed to the direct sunlight. Otherwise the appliance may be deformed, malfunction or generate odor.
-

TROUBLESHOOTING

Before Calling for Service

Please check the following before calling for service. If the problem persists, contact your local service center.

Normal operating sounds of the product

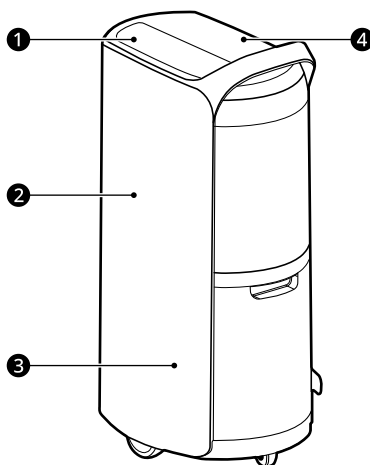

① Sound of wind

The volume of sound changes according to the angle of the louver.

② 'Buzzing' and 'grr-grr' (grinding) sounds

Sound may be heard until the circulation of the refrigerant stabilizes.

③ High frequency sound

The sound from the inverter compressor is a normal sound that occurs during operation.

④ 'Clack' sounds (part expansion sound)

When operating the dehumidifier, the sound is temporary due to temperature changes in the components and disappears after a certain period of time.

Operation

Call the service immediately in the following situations.

- Power cord is too hot or damaged.
- Error code is generated by self diagnosis.
- Water overflow even if the water tank is full.

Symptoms	Possible Cause & Solution
The appliance does not operate.	Is the power plug disconnected? <ul style="list-style-type: none"> • Connect it to an outlet correctly.
	Did the electricity get cut off? <ul style="list-style-type: none"> • Check the power to other products in the house.
	Is the water tank correctly installed? <ul style="list-style-type: none"> • Install the water tank correctly.
	Is the Bucket Full indicator lamp on? <ul style="list-style-type: none"> • Empty the water tank.
	Is the display showing dF? <ul style="list-style-type: none"> • Press the Start/Stop button when Auto Defrost ends.
	Is the desired humidity set higher than the room humidity? <ul style="list-style-type: none"> • Lower the desired humidity to below the room humidity.
There is little dehumidification.	Is only the ionizer function working? <ul style="list-style-type: none"> • Select Smart Dehumidification / Jet Dehumidification mode.
	Is the room temperature or humidity too low? <ul style="list-style-type: none"> • Check the desired humidity. • Use Laundry Dehumidification mode. • It is normal for less dehumidification to take place in the winter and in dry areas.
	Is the air inlet or outlet blocked? <ul style="list-style-type: none"> • Remove the obstruction. • Clean the filter.
Humidity does not seem to decrease much even though the product is running in dehumidification mode.	Is the door/window open? <ul style="list-style-type: none"> • Close the door/window.
	Is the room too big? <ul style="list-style-type: none"> • Use the dehumidifier in an adequately sized room.
	Is there an object generating steam nearby? <ul style="list-style-type: none"> • Do not use the dehumidifier together with other appliances.
The humidity reading on the status display is incorrect.	Is the dehumidifier obstructed in any way? <ul style="list-style-type: none"> • Keep the dehumidifier away from walls etc.

Symptoms	Possible Cause & Solution
The humidity reading on the status display is incorrect.	<p>Is the dehumidifier far away from the place you are trying to dehumidify?</p> <ul style="list-style-type: none"> The status display shows the humidity level in its current position, which may be different from the level in other positions.
It is taking a long time to dry laundry.	<p>Is the dry air reaching the laundry?</p> <ul style="list-style-type: none"> Move the dehumidifier closer to the laundry.
	<p>Are you trying to dry the laundry in a large room?</p> <ul style="list-style-type: none"> Use the dehumidifier in an adequately sized room.
	<p>Are you trying to dry too much laundry?</p> <ul style="list-style-type: none"> Reduce the amount of laundry.
I just removed the water tank and water is dripping from within the dehumidifier.	<p>Did you remove the water tank while the dehumidifier was running?</p> <ul style="list-style-type: none"> Remove the water tank when the Bucket Full indicator is lit.

LG ThinQ

Symptoms	Possible Cause & Solution
The product and the smartphone cannot be connected through Wi-Fi.	<p>Is the Wi-Fi password used to connect to the smartphone correct?</p> <ul style="list-style-type: none"> Press the Settings button on your smartphone, and then find your Wi-Fi in the network list. Press and hold the button to select [Clear Network], and then proceed with product registration again from the beginning.
	<p>Is your smartphone using mobile data rather than Wi-Fi?</p> <ul style="list-style-type: none"> In the smartphone's settings, turn off Mobile Data, turn on Wi-Fi, and then register the product.
	<p>Does the name (ID) of the wireless router contain special characters?</p> <ul style="list-style-type: none"> Set the name (ID) of the wireless router as a combination of numbers and English letters. Wi-Fi connection may be difficult if you enter special characters.
	<p>Is the frequency of the wireless router not 2.4 GHz?</p> <ul style="list-style-type: none"> When connecting the product via Wi-Fi, only a 2.4 GHz network can be used. Set the wireless router to 2.4 GHz and then connect. To check the frequency of your wireless router, contact your Internet carrier or router manufacturer.
	<p>Are the product and the wireless router too far apart?</p> <ul style="list-style-type: none"> If the distance between the product and the wireless router is too great, the wireless signal may be weak, and the connection may not be smooth. Move the wireless router closer to the product.

APPENDIX

Information

APPLIANCE SPECIFICATIONS

- Appearance and specifications may vary without notice to improve the quality of the appliance.

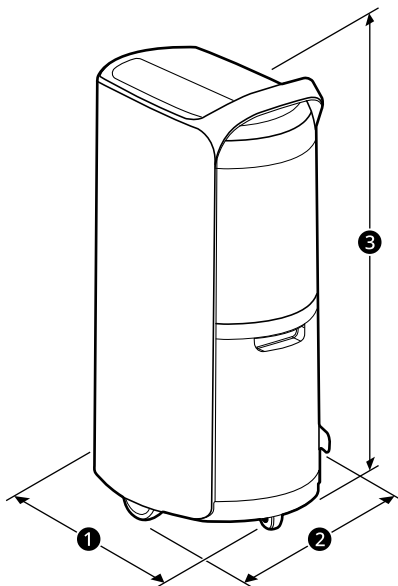

Name	MD19GQGE0
Power	AC 220 - 240 V~ 50/60 Hz
Exterior Dimensions (1 x 2 x 3)	415 mm x 296 mm x 715 mm

