



ENGLISH

FRANÇAIS

ESPAÑOL

INSTALLATION MANUAL

AIR CONDITIONER

Please read this installation manual completely before installing the product. Installation work must be performed in accordance with the national wiring standards by authorized personnel only. Please retain this installation manual for future reference after reading it thoroughly.

Ceiling Cassette



MFL05745002
Rev.05_072125

www.lghvac.com
www.lg.com

Copyright © 2024 - 2025 LG Electronics Inc. All Rights Reserved.

Tips for Saving Energy

Here are some tips that will help you minimize the power consumption when you use the air conditioner.

You can use your air conditioner more efficiently by referring to the instructions below:

- Do not cool excessively indoors. This may be harmful for your health and may consume more electricity.
- Block sunlight with blinds or curtains while you are operating the air conditioner.
- Keep doors or windows closed tightly while you are operating the air conditioner.
- Adjust the direction of the air flow vertically or horizontally to circulate indoor air.
- Speed up the fan to cool or warm indoor air quickly, in a short period of time.
- Open windows regularly for ventilation as the indoor air quality may deteriorate if the air conditioner is used for many hours.
- Clean the air filter once every 2 weeks. Dust and impurities collected in the air filter may block the air flow or weaken the cooling / dehumidifying functions.

For your records

Staple your receipt to this page in case you need it to prove the date of purchase or for warranty purposes.

Write the model number and the serial number here:

Model number : _____

Serial number : _____

You can find them on a label on the side of each unit.

Dealer's name : _____

Date of purchase : _____

TABLE OF CONTENTS

2 TIPS FOR SAVING ENERGY

4 INSTALLATION PARTS

7 MULTI V CASSETTE INDOOR UNITS INSTALL TIPS

8 SAFETY INSTRUCTIONS

- 8 Installation
- 11 Wiring
- 12 Operation
- 12 Service & Installation

17 CASSETTE INDOOR UNITS INSTALLATION GENERAL INFORMATION

- 17 Cassette Indoor Units Installation General Information
- 17 Minimum Floor Area

38 INSTALLATION





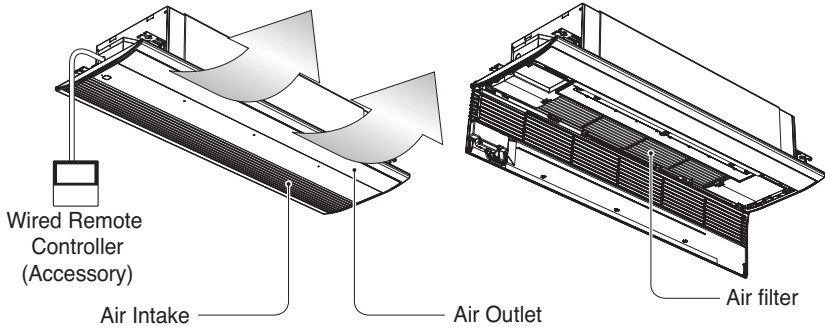

- 38 Selection of the best location
- 39 Ceiling dimension and hanging bolt location
- 42 Wiring Connection
- 47 Plumbing materials and storage methods
- 49 Flaring Work
- 51 Installation of Decorative Panel (Accessory) 1-Way
- 55 Installation of Decoration Panel (2 WAY)
- 56 Installation of Decoration Panel (4 Way)
- 57 Installation Branch Duct (TM-A 4way)
- 63 Drain Piping
- 65 Ceiling Height Selection
- 65 DIP Switch Setting
- 66 Group Control Setting
- 70 Airborne Noise Emission
- 70 R32 Leak Detection System





Installation Parts

1-WAY



Installation Tool

Name	Drain hose	Clamp metal	Washer	Plastic band	Pipe insulation
Quantity	1 EA	2 EA	8 EA	6 EA	1 SET
Shape		 For drain hose and pipe	 for hanging bracket	 For drain hose insulation (2 EA)  For pipe insulation (4 EA)	 For gas pipe (1 EA)  For liquid pipe (1 EA)





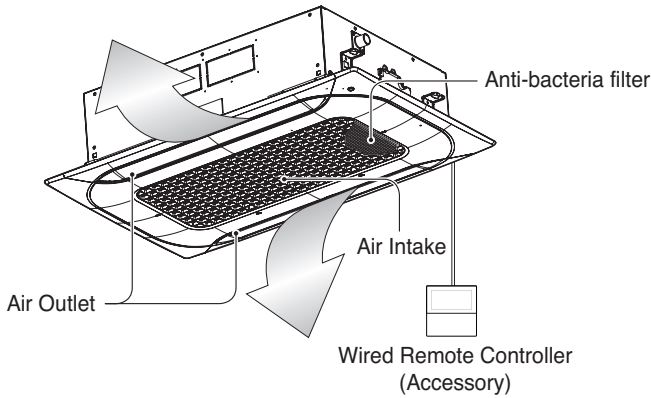

Name	Drain hose insulation	Drain cover	Screw	(Other) • Paper pattern for installation • Manual
Quantity	1 EA	1 EA	2 EA	
Shape			  For drain cover	



• Screws for fixing panels are attached to decoration panel.

2-WAY



Installation Tool

Name	Drain hose	Clamp metal	Washer	Plastic band	Pipe insulation
Quantity	1 EA	2 EA	8 EA	4 EA	1 SET
Shape		 For drain hose and pipe	 for hanging bracket	 For pipe insulation (4 EA)	 For gas pipe (1 EA)  For liquid pipe (1 EA)





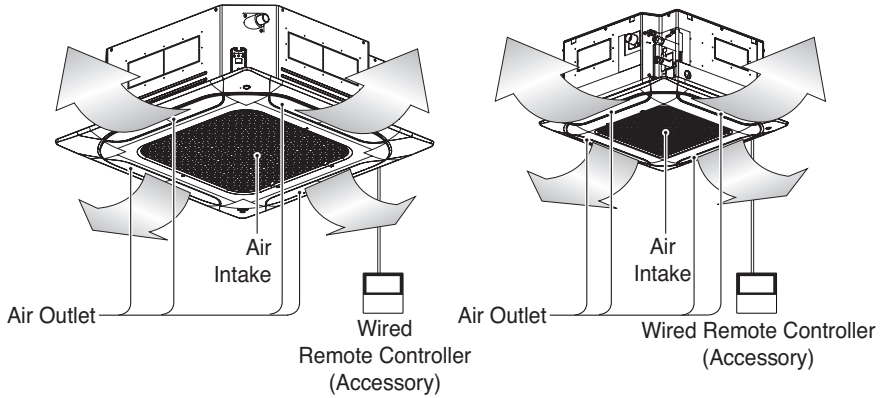

Name	Conduit mounting plate	Screw	(Other) • Paper pattern for installation • Manual
Quantity	1 EA	1 EA	
Shape		For Conduit mounting plate 	







• Screws for fixing panels are attached to decoration panel.

4-WAY



Installation Tool

Name	Drain hose	Clamp metal	Washer	Plastic band	Pipe insulation
Quantity	1 EA	2 EA	8 EA	4 EA	1 SET
Shape	 TM-A/TP-B  TQ/TR	 For drain hose and pipe	 for hanging bracket	 For pipe insulation (4 EA)	 For gas pipe (1 EA)  For liquid pipe (1 EA)

Name	Drain hose insulation	Conduit mounting plate	Screw	(Other) • Paper pattern for installation • Manual
Quantity	1 EA	1 EA	1 / 2 EA	
Shape	 TM-A/TP-B	 TM-A/TP-B  TQ/TR	For Conduit mounting plate TM-A/TP-B (1EA)  TQ/TR (2EA)  	

• Screws for fixing panels are attached to decoration panel.

Multi V Cassette Indoor Units Install Tips

The following pages present an overview of installation of LG's Multi V, Multi F, and Single Zone Cassette indoor units, and is intended to supplement the technical and installation information provided through www.lghvac.com. The review of basic operation and maintenance skills must reinforce industry established practices and provide helpful tips to make equipment operation successful.

NOTE

⊗ The installation guide is NOT intended to be a replacement for LG installation manuals, nor is it intended to cover ALL the logistics of operating and maintenance of VRF systems. For detailed information on the procedures mentioned here, refer to the installation manual specific to your product. Always comply with applicable local, state, and federal codes.

The following safety guidelines are intended to prevent unforeseen risks or damage from unsafe or incorrect operation of the appliance. The guidelines are separated into 'WARNING' and 'CAUTION' as described below.





⚠ This symbol is displayed to indicate matters and operations that can cause risk. Read the part with this symbol carefully and follow the instructions in order to avoid risk.

⚠ WARNING

This indicates that the failure to follow the instructions can cause serious injury or death.

⚠ CAUTION

This indicates that the failure to follow the instructions can cause the minor injury or damage to the product.

	<p>Read the precautions in this manual carefully before operating the unit.</p>
	<p>This symbol indicates that the Operation Manual should be read carefully.</p>
	<p>This appliance is filled with flammable refrigerant.</p>
	<p>This symbol indicates that a service personnel should be handling this equipment with reference to the Installation Manual.</p>

Safety Instructions

Installation

⚠ CAUTION

- Be very careful when transporting the product. There is a risk of the product falling and causing physical injury.
 - Use appropriate moving equipment to transport each frame ensure the equipment is capable of supporting the weight of the equipment.
- The Limited Warranty is void and of no effect, and LG will have no liability hereunder to any Customer or third party, to the extent any of the following occur: acts, omissions, and conduct of any and all third parties including, but not limited to, the installing contractor and any repairs, service or maintenance by unauthorized or unqualified persons.
- Do not install the unit in potentially explosive atmospheres.
- The installation of pipe-work shall be kept to a minimum.
- Any person who is involved with working on or breaking into a refrigerant circuit should hold a current valid certificate from an industry-accredited assessment authority, which authorises their competence to handle refrigerants safely in accordance with an industry recognised assessment specification.
- When mechanical connectors are reused indoors, sealing parts shall be renewed.
- When flared joints are reused indoors, the flare part shall be re-fabricated.

⚠ WARNING

- An authorized, trained technician licensed locally and at the state level must install the unit.
 - Improper installation by the user may result in fire, explosion, electric shock, physical injury or death.
- Wear protective gloves when handling equipment. Sharp edges may cause personal injury.
- Always check for system refrigerant leaks after the unit has been installed or serviced.
 - Exposure to high concentration levels of refrigerant gas may lead to illness or death.
- Dispose the packing materials safely.
 - Packing materials, such as nails and other metal or wooden parts, may cause puncture wounds or other injuries. Tear apart and throw away plastic packaging bags so that children may not play with them and risk suffocation and death.
- Install the unit considering the potential for strong winds or earthquakes.
 - Improper installation may cause the unit to fall over, resulting in physical injury or death.
- Install the unit in a safe location where nobody can step on or fall onto it. ☹ Do not install the unit on a defective stand.
 - It may result in an accident that causes physical injury or death.
- Properly insulate all cold surfaces to prevent “sweating.”
 - Cold surfaces such as uninsulated piping can generate condensate that could drip, causing a slippery surface that creates a risk of slipping, falling, and personal injury.
- Do not use means to accelerate the defrosting process or to clean, other than those recommended by the manufacturer.
- The appliance shall be stored in a room without continuously operating ignition sources (for example: open flames, an operating gas appliance or an operating electric heater.)
- Do not pierce or burn.
- Be aware that refrigerants may not contain an odour.
- The manufacturer may provide other suitable examples or may provide additional information about the refrigerant odour.

- Pipe-work including piping material, pipe routing, and installation shall include protection from physical damage in operation and service, and be in compliance with national and local codes and standards, such as ASHRAE 15, ASHRAE 15.2, IAPMO Uniform Mechanical Code, ICC International Mechanical Code, or CSA B52.
- An unventilated area where the appliance using flammable refrigerants is installed shall be so constructed that should any refrigerant leak, it will not stagnate so as to create a fire or explosion hazard.
- Field-made refrigerant joints indoors shall be tightness tested according to the following requirements: The test method shall have a sensitivity of 5 grams per year of refrigerant or better under a pressure of at least 0,25 times the maximum allowable pressure. No leak shall be detected;
- After completion of field piping for split systems, the field pipework shall be pressure tested with an inert gas and then vacuum tested prior to refrigerant charging, according to the following requirements:
 - The minimum test pressure for the low side of the system shall be the low side design pressure and the minimum test pressure for the high side of the system shall be the high side design pressure, unless the high side of the system, cannot be isolated from the low side of the system in which case the entire system shall be pressure tested to the low side design pressure.
 - The test pressure after removal of pressure source shall be maintained for at least 1 h with no decrease of pressure indicated by the test gauge, with test gauge resolution not exceeding 5% of the test pressure.
 - During the evacuation test, after achieving a vacuum level specified in the manual or less, the refrigeration system shall be isolated from the vacuum pump and the pressure shall not rise above 1 500 microns within 10 min. The vacuum pressure level shall be specified in the manual, and shall be the lessor of 500 microns or the value required for compliance with national and local codes and standards, which may vary between residential, commercial, and industrial buildings.

Qualification of workers

The manual shall contain specific information about the required qualification of the working personnel for maintenance, service and repair operations. Every working procedure that affects safety means shall only be carried out by qualified person by manufacturer.

Examples for such working procedures are:

- Breaking into the refrigerating circuit;
 - Opening of sealed components;
 - Opening of ventilated enclosures.
-
- Refrigerant tubing shall be protected or enclosed to avoid damage.
 - Flexible refrigerant connectors (such as connecting lines between the indoor and outdoor unit) that may be displaced during normal operations shall be protected against mechanical damage.
 - A brazed, welded, or mechanical connection shall be made before opening the valves to permit refrigerant to flow between the refrigerating system parts.
 - Keep any required ventilation openings clear of obstruction.
 - Mechanical connections (mechanical connectors or flared joints) shall be accessible for maintenance purposes.
 - Flexible pipe elements shall be protected against mechanical damage, excessive stress by torsion, or other forces. They should be checked for mechanical damage annually.
 - Protection devices, piping and fittings shall be protected as far as possible against adverse environmental effects, for example, the danger of water collecting and freezing in relief pipes or the accumulation of dirt and debris.
 - Precautions shall be taken to avoid excessive vibration or pulsation to refrigerating piping.

- Piping in refrigerating systems shall be so designed and installed to minimize the likelihood hydraulic shock damaging the system.
- Provision shall be made for expansion and contraction of long runs of piping.
- Steel pipes and components shall be protected against corrosion with a rustproof coating before applying any insulation.
- Non-duct connected appliances containing A2L refrigerants with the supply and return air openings in the conditioned space may have the body of the appliance may be installed in open areas such as false ceilings not being used as return air plenums, as long as the conditioned air does not directly communicate with the air of the false ceiling.

NOTE

- Properly insulate all cold surfaces to prevent “sweating”.
 - Cold surfaces such as uninsulated piping can generate condensate that may drip and cause a slippery surface condition and / or water damage to interior surfaces.
- Always check for system refrigerant leaks after the unit has been installed.
 - Low refrigerant levels may cause product failure.
- Ⓞ Do not make refrigerant substitutions. Use R32 only.
 - If a different refrigerant is used, or air mixes with original refrigerant, the unit will malfunction and be damaged.
- Keep the unit upright during installation to avoid vibration or water leakage.
- When connecting refrigerant tubing, remember to allow for pipe expansion.
 - Improper piping may cause refrigerant leaks and system malfunction.
- Ⓞ Do not install indoor units in laundry rooms.
- Ⓞ Do not install the outdoor unit in a noise-sensitive area. Periodically check that the outdoor frame is not damaged.
 - There is a risk of equipment damage.
- Install the unit in a safe location where nobody can step on or fall onto it. Ⓞ Do not install the unit on a defective stand.
 - There is a risk of unit and property damage.
- Install the drain hose to ensure adequate drainage.
 - There is a risk of water leakage and property damage.
- Ⓞ Do not store or use flammable gas / combustibles near the unit.
 - There is a risk of product failure.
- Do not use this equipment in mission critical or special-purpose applications such as preserving foods, works of art, wine coolers or refrigeration.
- This equipment is designed to provide comfort cooling and heating.
- Do not place IDUs in an environment where the IDUs may be exposed to harmful volatile organic compounds (VOCs), or in environments where there is improper air make up or supply or inadequate ventilation. If there are concerns about VOCs in the environment where the IDUs are installed, proper air make up or supply and/or adequate ventilation should be provided.
- Additionally, in buildings where IDUs will be exposed to VOCs, consider a third party factory-applied epoxy coating to the fan coils for each IDU where the entire coil is dipped, not sprayed.

Wiring**⚠ WARNING**

- High voltage electricity is required to operate this system. Adhere to applicable building codes: National Electrical Code (NEC) for U.S. and Mexico, Canada Electrical Code (CE) for Canada and these instructions when wiring.
 - Improper connections and inadequate grounding can cause accidental injury or death.
- Always ground the unit following local, state, and national Codes.
 - There is risk of fire, electric shock, and physical injury or death.
- Properly size all circuit breakers or fuses.
 - There is risk of fire, electric shock, explosion, physical injury or death.
- The information contained in this manual is intended for use by an industry-qualified, experienced, certified electrician familiar with NEC for U.S. and Mexico, or CE for Canada who is equipped with the proper tools and test instruments.
 - Failure to carefully read and follow all instructions in this manual can result in equipment malfunction, property damage, personal injury or death.
- Refer to local, state, and federal codes, and use power wires of sufficient current capacity and rating.
 - Wires that are too small may generate heat and cause a fire.
- All electric work must be performed by a licensed electrician and conform to local building codes or, in the absence of local codes, with NEC for U.S. and Mexico, or CE for Canada, and the instructions given in this manual.
 - If the power source capacity is inadequate or the electric work is not performed properly, it may result in fire, electric shock, physical injury or death.
- Secure all field wiring connections with appropriate wire strain relief.
 - Improperly securing wires will create undue stress on equipment power lugs. Inadequate connections may generate heat, cause a fire and physical injury or death.
- Properly tighten all power lugs.
 - Loose wiring may overheat at connection points, causing a fire, physical injury or death.
- Ⓞ Do not change the settings of the protection devices.
 - If the pressure switch, thermal switch, or other protection devices are bypassed or forced to work improperly, or parts other than those specified by LG are used, there is risk of fire, electric shock, explosion, and physical injury or death.
- The appliance shall be installed in accordance with national wiring regulations.
- Means for disconnection must be incorporated in the fixed wiring in accordance with the wiring rules.
- If the supply cord is damaged, it must be replaced by the manufacturer, its service agent or similarly qualified persons in order to avoid a hazard.

NOTE

- Ⓞ Do not supply power to the unit until all electrical wiring, controls wiring, piping, installation, and refrigerant system evacuation are completed.

Operation

⚠ CAUTION

- This appliance is not intended for the purposes of cooling INFORMATION TECHNOLOGY EQUIPMENT.
- Servicing shall only be performed as recommended by the equipment manufacturer. Maintenance and repair requiring the assistance of other skilled personnel shall be carried out under the supervision of the person competent in the use of flammable refrigerants.

⚠ WARNING

- The appliance shall be stored so as to prevent mechanical damage from occurring.
- This appliance is not intended for use by persons (including children) with reduced physical, sensory or mental capabilities or lack of experience and knowledge, unless they have been given supervision or instruction concerning use of the appliance by a person responsible for their safety. Children should be supervised to ensure that they do not play with the appliance.
- LEAK DETECTION SYSTEM installed. Unit must be powered except for service. This unit is equipped with a refrigerant leak detector for safety. To be effective, the unit must be electrically powered at all times after installation, other than when servicing.

Service & Installation

⚠ CAUTION

- Servicing shall be performed only as recommended by the manufacturer.

⚠ WARNING

Checks to the area

Prior to beginning work on systems containing flammable refrigerants, safety checks are necessary to ensure that the risk of ignition is minimised. For repair to the refrigerating system, the following precautions shall be complied with prior to conducting work on the system.

Work procedure

Work shall be undertaken under a controlled procedure so as to minimise the risk of a flammable gas or vapour being present while the work is being performed.

General work area

All maintenance staff and others working in the local area shall be instructed on the nature of work being carried out. Work in confined spaces shall be avoided.

Checking for presence of refrigerant

The area shall be checked with an appropriate refrigerant detector prior to and during work, to ensure the technician is aware of potentially flammable atmospheres. Ensure that the leak detection equipment being used is suitable for use with flammable refrigerants, i.e. non-sparking, adequately sealed or intrinsically safe.

Presence of fire extinguisher

If any hot work is to be conducted on the refrigerating equipment or any associated parts, appropriate fire extinguishing equipment shall be available to hand. Have a dry powder or CO₂ fire extinguisher adjacent to the charging area.

No ignition sources

No person carrying out work in relation to a refrigerating system which involves exposing any pipe work shall use any sources of ignition in such a manner that it may lead to the risk of fire or explosion.

All possible ignition sources, including cigarette smoking, should be kept sufficiently far away from the site of installation, repairing, removing and disposal, during which refrigerant can possibly be released to the surrounding space. Prior to work taking place, the area around the equipment is to be surveyed to make sure that there are no flammable hazards or ignition risks. "No Smoking" signs shall be displayed.

Ventilated area

Ensure that the area is in the open or that it is adequately ventilated before breaking into the system or conducting any hot work. A degree of ventilation shall continue during the period that the work is carried out.

The ventilation should safely disperse any released refrigerant and preferably expel it externally into the atmosphere.

Checks to the refrigerating equipment

Where electrical components are being changed, they shall be fit for the purpose and to the correct specification.

At all times the manufacturer's maintenance and service guidelines shall be followed. If in doubt consult the manufacturer's technical department for assistance.

The following checks shall be applied to installations using flammable refrigerants:

- The actual refrigerant charge is in accordance with the room size within which the refrigerant containing parts are installed
- The ventilation machinery and outlets are operating adequately and are not obstructed
- If an indirect refrigerating circuit is being used, the secondary circuit shall be checked for the presence of refrigerant
- Marking to the equipment continues to be visible and legible. Markings and signs that are illegible shall be corrected
- Refrigerating pipe or components are installed in a position where they are unlikely to be exposed to any substance which may corrode refrigerant containing components, unless the components are constructed of materials which are inherently resistant to being corroded or are suitably protected against being so corroded.

Checks to electrical devices

Repair and maintenance to electrical components shall include initial safety checks and component inspection procedures. If a fault exists that could compromise safety, then no electrical supply shall be connected to the circuit until it is satisfactorily dealt with. If the fault cannot be corrected immediately but it is necessary to continue operation, an adequate temporary solution shall be used. This shall be reported to the owner of the equipment so all parties are advised.

Initial safety checks shall include:

- Capacitors are discharged: this shall be done in a safe manner to avoid possibility of sparking.
- No live electrical components and wiring are exposed while charging, recovering or purging the system.
- Continuity of earth bonding

Repairs to sealed components

Sealed electrical components shall be replaced.

Repair to intrinsically safe components

Intrinsically safe components must be replaced.

Cabling

Check that cabling will not be subject to wear, corrosion, excessive pressure, vibration, sharp edges or any other adverse environmental effects. The check shall also take into account the effects of aging or continual vibration from sources such as compressors or fans.

Detection of flammable refrigerants

Under no circumstances shall potential sources of ignition be used in the searching for or detection of refrigerant leaks. A halide torch (or any other detector using a naked flame) shall not be used.

Leak detection methods

The following leak detection methods are deemed acceptable for all refrigerant systems.

Electronic leak detectors may be used to detect refrigerant leaks but, in the case of **FLAMMABLE REFRIGERANTS**, the sensitivity may not be adequate, or may need re-calibration. (Detection equipment shall be calibrated in a refrigerant-free area.) Ensure that the detector is not a potential source of ignition and is suitable for the refrigerant used. Leak detection equipment shall be set at a percentage of the LFL of the refrigerant and shall be calibrated to the refrigerant employed, and the appropriate percentage of gas (25 % maximum) is confirmed.

Leak detection fluids are also suitable for use with most refrigerants but the use of detergents containing chlorine shall be avoided as the chlorine may react with the refrigerant and corrode the copper pipe-work.

NOTE

Examples of leak detection fluids are.

- Bubble method.
- Fluorescent method agents.

If a leak is suspected, all naked flames shall be removed / extinguished.

If a leakage of refrigerant is found which requires brazing, all of the refrigerant shall be recovered from the system, or isolated (by means of shut off valves) in a part of the system remote from the leak. Removal of refrigerant shall be according to removal and evacuation procedure.

Removal and evacuation

When breaking into the refrigerant circuit to make repairs – or for any other purpose – conventional procedures shall be used. However, for flammable refrigerants it is important that best practice be followed, since flammability is a consideration.

The following procedure shall be adhered to:

- Safely remove refrigerant following local and national regulations;
- Evacuate;
- Purge the circuit with inert gas (optional for A2L);
- Evacuate (optional for A2L);
- Continuously flush or purge with inert gas when using flame to open circuit; and
- Open the circuit.

The refrigerant charge shall be recovered into the correct recovery cylinders if venting is not allowed by local and national codes. For appliances containing flammable refrigerants, the system shall be purged with oxygen-free nitrogen to render the appliance safe for flammable refrigerants. This process might need to be repeated several times.

Compressed air or oxygen shall not be used for purging refrigerant systems.

For appliances containing flammable refrigerants, refrigerants purging shall be achieved by breaking the vacuum in the system with oxygen-free nitrogen and continuing to fill until the working pressure is achieved, then venting to atmosphere, and finally pulling down to a vacuum (optional for A2L). This process shall be repeated until no refrigerant is within the system (optional for A2L). When the final oxygen-free nitrogen charge is used, the system shall be vented down to atmospheric pressure to enable work to take place.

The outlet for the vacuum pump shall not be close to any potential ignition sources, and ventilation shall be available.

Charging procedures

In addition to conventional charging procedures, the following requirements shall be followed.

- Ensure that contamination of different refrigerants does not occur when using charging equipment. Hoses or lines shall be as short as possible to minimise the amount of refrigerant contained in them.
- Cylinders shall be kept in an appropriate position according to the instruction.
- Ensure that the refrigerating system is earthed prior to charging the system with refrigerant.
- Label the system when charging is complete (if not already).
- Extreme care shall be taken not to overfill the refrigerating system.

Prior to recharging the system, it shall be pressure tested with the appropriate purging gas.

The system shall be leak-tested on completion of charging but prior to commissioning. A follow up leak test shall be carried out prior to leaving the site.

Decommissioning

Before carrying out this procedure, it is essential that the technician is completely familiar with the equipment and all its detail.

It is recommended good practice that all refrigerants are recovered safely.

Prior to the task being carried out, an oil and refrigerant sample shall be taken in case analysis is required prior to re-use of recovered refrigerant.

It is essential that electrical power is available before the task is commenced.

- a) Become familiar with the equipment and its operation.
- b) Isolate system electrically.
- c) Before attempting the procedure ensure that:
 - Mechanical handling equipment is available, if required, for handling refrigerant cylinders
 - All personal protective equipment is available and being used correctly
 - The recovery process is supervised at all times by a competent person
 - Recovery equipment and cylinders conform to the appropriate standards.
- d) Pump down refrigerant system, if possible.
- e) If a vacuum is not possible, make a manifold so that refrigerant can be removed from various parts of the system.
- f) Make sure that cylinder is situated on the scales before recovery takes place.
- g) Start the recovery machine and operate in accordance with instructions.
- h) Do not overfill cylinders. (No more than 80 % volume liquid charge).
- i) Do not exceed the maximum working pressure of the cylinder, even temporarily.

- j) When the cylinders have been filled correctly and the process completed, make sure that the cylinders and the equipment are removed from site promptly and all isolation valves on the equipment are closed off.
- k) Recovered refrigerant shall not be charged into another refrigerating system unless it has been cleaned and checked.

Labelling

Equipment shall be labelled stating that it has been de-commissioned and emptied of refrigerant.

The label shall be dated and signed.

Ensure that there are labels on the equipment stating the equipment contains flammable refrigerant.

Safety Shut-Off Valve

Safety shut off valves installation shall avoid hydraulic shock.

Safety shut off valves shall be located in a space with a room volume large enough to comply with the following formula.

Safety shut off valve shall be positioned to enable access for maintenance by an authorized person.

When calculating the minimum floor room area, the releasable charge (m_{rel}) value replaces total refrigerant charge in system (m).

The releasable charge (m_{rel}) is not related to total refrigerant charge in system (m).

Recovery

When removing refrigerant from a system, either for servicing or decommissioning, it is recommended good practice that all refrigerants are removed safely.

When transferring refrigerant into cylinders, ensure that only appropriate refrigerant recovery cylinders are employed.

Ensure that the correct number of cylinders for holding the total system charge is available.

All cylinders to be used are designated for the recovered refrigerant and labelled for that refrigerant (i.e. special cylinders for the recovery of refrigerant).

Cylinders shall be complete with pressure-relief valve and associated shut-off valves in good working order.

Empty recovery cylinders are evacuated and, if possible, cooled before recovery occurs.

The recovery equipment shall be in good working order with a set of instructions concerning the equipment that is at hand and shall be suitable for the recovery of the flammable refrigerant.

If in doubt, the manufacturer should be consulted. In addition, a set of calibrated weighing scales shall be available and in good working order.

Hoses shall be complete with leak-free disconnect couplings and in good condition.

The recovered refrigerant shall be processed according to local legislation in the correct recovery cylinder, and the relevant waste transfer note arranged.

Do not mix refrigerants in recovery units and especially not in cylinders .

If compressors or compressor oils are to be removed, ensure that they have been evacuated to an acceptable level to make certain that flammable refrigerant does not remain within the lubricant.

The compressor body shall not be heated by an open flame or other ignition sources to accelerate this process.

When oil is drained from a system, it shall be carried out safely.

Cassette Indoor Units Installation General Information

Cassette Indoor Units Installation General Information

Cassette Indoor Units Installation Tips

This document contains general installation tips for installing LG cassette indoor units (IDU). Follow all applicable local and national codes during installation. For more detailed information, refer to the individual unit's installation manual on www.lghvac.com.

The typical unit installation includes:

- Minimum Floor Area.
- Selecting the installation location.
- Installing the unit.
- Connecting refrigerant pipes.
- Connecting drain pipe.
- Connecting communication and power wiring.
- Installing the remote controller (if applicable).
- R32 Leak Detection System.

Always follow your system diagrams, including the LATS diagram (if applicable).

Minimum Floor Area

Minimum Floor Area

The appliance shall be installed, operated and stored in a room with a floor area larger than the minimum floor area. Installers must use refrigerant charge amounts that meet the requirements to comply with use conditions required in SNAP Rules.

In this manual, provide a simple method to find minimum floor area in table. For more accurate value, use LATS or-R Checker.

Single-Split System(UL 60335-2-40:2019 Edition 3)

- Minimum floor area for Single Split System(UL 60335-2-40:2019 Edition 3)

Multi-Split System (UL 60335-2-40:2019 Edition 3)

- Minimum floor area for Multi-Split System (UL 60335-2-40:2019 Edition 3)
- Minimum floor area for Multi-Split System with Alarm Kit (UL 60335-2-40:2019 Edition 3)
- Minimum floor area for Multi-Split System with Safety Shut Off Valve (UL 60335-2-40:2019 Edition 3)

ETRS Unit(UL 60335-2-40:2022 Edition 4)

- Minimum floor area for ETRS unit (UL 60335-2-40:2022 Edition 4)
- Minimum floor area for ETRS unit with Safety Shut Off Valve (UL 60335-2-40:2022 Edition 4)

Minimum floor area for Single-Split System (UL 60335-2-40:2019 Edition 3)

The following instructions apply when only one indoor unit is connected to an outdoor unit.

- Use the <Table1> to determine the minimum floor area with m and h.
- If m is not in table, use the next larger value.
- m : Total refrigerant charge in system
- Total refrigerant charge in system : factory refrigerant charge +additional refrigerant charge.
- h : Installed height.
- A_{min} : Minimum floor area.

<Table 1> : Table for Single-Split System.

Maximum of m is 15.91 kg (35.07 lbs)

m		Minimum floor Area (Installed Height)					
		A _{min} (h≥1.8 m, 5.91 ft)		A _{min} (h≥2.0 m, 6.56 ft)		A _{min} (h≥2.2 m, 7.22 ft)	
kg	lbs	m ²	ft ²	m ²	ft ²	m ²	ft ²
≤ 1.83	≤ 4.04	-	-	-	-	-	-
1.84	4.05	13.37	143.92	12.03	129.49	10.94	117.76
2.00	4.40	14.53	156.40	13.08	140.80	11.89	127.99
2.20	4.85	15.98	172.01	14.38	154.79	13.08	140.80
2.40	5.29	17.43	187.62	15.69	168.89	14.27	153.61
2.60	5.73	18.89	203.34	17.00	182.99	15.45	166.31
2.80	6.17	20.34	218.94	18.31	197.09	16.64	179.12
3.00	6.61	21.79	234.55	19.61	211.09	17.83	191.93
3.20	7.05	23.24	250.16	20.92	225.19	19.02	204.73
3.40	7.49	24.70	265.77	22.23	239.29	20.21	217.54
3.60	7.93	26.15	281.48	23.53	253.28	21.40	230.35
3.80	8.37	27.60	297.09	24.84	267.38	22.58	243.05
4.00	8.81	29.05	312.70	26.15	281.48	23.77	255.86
4.20	9.25	30.51	328.41	27.46	295.58	24.96	268.67
4.40	9.70	31.96	344.02	28.76	309.58	26.15	281.48
4.60	10.14	33.41	359.63	30.07	323.68	27.34	294.29
4.80	10.58	34.86	375.23	31.38	337.78	28.53	307.10
5.00	11.02	36.32	390.95	32.68	351.77	29.71	319.80
5.20	11.46	37.77	406.56	33.99	365.87	30.90	332.61
5.40	11.90	39.22	422.17	35.30	379.97	32.09	345.42
5.60	12.34	40.67	437.77	36.61	394.07	33.28	358.23
5.80	12.78	42.13	453.49	37.91	408.06	34.47	371.04
6.00	13.22	43.58	469.10	39.22	422.17	35.66	383.85
6.20	13.66	45.03	484.70	40.53	436.27	36.84	396.55
6.40	14.10	46.48	500.31	41.84	450.37	38.03	409.36
6.60	14.55	47.94	516.03	43.14	464.36	39.22	422.17
6.80	14.99	49.39	531.63	44.45	478.46	40.41	434.97
7.00	15.43	50.84	547.24	45.76	492.56	41.60	447.78
7.20	15.87	52.29	562.85	47.06	506.55	42.79	460.59
7.40	16.31	53.75	578.57	48.37	520.66	43.97	473.29
7.60	16.75	55.20	594.17	49.68	534.76	45.16	486.10
7.80	17.19	56.61	624.42	50.99	548.86	46.35	498.91
8.00	17.63	61.02	656.82	52.29	562.85	47.54	511.72
8.20	18.07	64.11	690.08	53.60	576.95	48.73	524.53
8.40	18.51	67.28	724.20	54.91	591.05	49.92	537.34
8.60	18.95	70.52	759.08	57.12	614.84	51.10	550.04
8.80	19.40	73.84	794.81	59.81	643.79	52.29	562.85
9.00	19.84	77.23	831.30	62.56	673.40	53.48	575.66
9.20	20.28	80.70	868.65	65.37	703.64	54.67	588.47
9.40	20.72	84.25	906.86	68.24	734.53	56.40	607.09
9.60	21.16	87.87	945.83	71.18	766.18	58.82	633.14
9.80	21.60	91.57	985.66	74.17	798.36	61.30	659.83
10.00	22.04	95.34	1026.24	77.23	831.30	63.83	687.07
10.20	22.48	99.20	1067.78	80.35	864.89	66.41	714.84
10.40	22.92	103.12	1109.98	83.53	899.11	69.03	743.04
10.60	23.36	107.13	1153.14	86.77	933.99	71.72	771.99
10.80	23.80	111.21	1197.06	90.08	969.62	74.45	801.38
11.00	24.25	115.37	1241.84	93.45	1005.89	77.23	831.30
11.20	24.69	119.60	1287.37	96.88	1042.81	80.06	861.76
11.40	25.13	123.91	1333.76	100.37	1080.38	82.95	892.87
11.60	25.57	128.29	1380.91	103.92	1118.59	85.88	924.41
11.80	26.01	132.76	1429.02	107.53	1157.45	88.87	956.59
12.00	26.45	137.29	1477.78	111.21	1197.06	91.91	989.32
12.20	26.89	141.91	1527.51	114.95	1237.32	95.00	1022.58
12.40	27.33	146.60	1577.99	118.75	1278.22	98.14	1056.38
12.60	27.77	151.37	1629.34	122.61	1319.77	101.33	1090.71
12.80	28.21	156.21	1681.44	126.53	1361.96	104.57	1125.59
13.00	28.66	161.13	1734.39	130.51	1404.80	107.86	1161.00
13.20	29.10	166.12	1788.11	134.56	1448.40	111.21	1197.06
13.40	29.54	171.20	1842.79	138.67	1492.64	114.60	1233.55
13.60	29.98	176.34	1898.11	142.84	1537.52	118.05	1270.68
13.80	30.42	181.57	1954.41	147.07	1583.05	121.55	1308.36
14.00	30.86	186.87	2011.46	151.37	1629.34	125.10	1346.57
14.20	31.30	192.25	2069.37	155.72	1676.16	128.70	1385.32
14.40	31.74	197.70	2128.03	160.14	1723.74	132.35	1424.61
14.60	32.18	203.23	2187.55	164.62	1771.96	136.05	1464.44
14.80	32.62	208.84	2247.94	169.16	1820.83	139.80	1504.80
15.00	33.06	214.52	2309.08	173.76	1870.34	143.60	1545.70
15.20	33.51	220.28	2371.08	178.43	1920.61	147.46	1587.25
15.40	33.95	226.11	2433.83	183.15	1971.42	151.37	1629.34
15.60	34.39	232.02	2497.45	187.94	2022.97	155.32	1671.86
15.80	34.83	238.01	2561.92	192.79	2075.18	159.33	1715.02
15.91	35.07	241.34	2597.77	195.48	2104.13	161.56	1739.02

Minimum floor area for Multi-Split System (UL 60335-2-40:2019 Edition 3)

The following instructions apply when two or more independently controlled indoor units are installed on a single refrigeration system. Height of room where indoor units are installed must be higher than 2.0 m (6.56 ft).

- Use the <Table 2> to determine the minimum floor area with m .
- If m is not in table, use the next larger value.
- m : Total refrigerant charge in system.
- Total refrigerant charge in system : factory refrigerant charge + additional refrigerant charge.
- A_{\min} : minimum floor area.

NOTE

- Maximum total refrigerant charge in multi-split system is product of 15.91 kg (35.07 lbs) and number of indoor units connected with single refrigerant system, not exceed 63.64 kg (140.30 lbs)
- Indoor units of multi-split system shall not be used in sealed room without ventilation to the outside of the room.
- Indoor units of multi-split system shall not be installed on the lowest underground floor of the building.

Minimum floor area for Multi-Split System with Alarm Kit (UL 60335-2-40:2019 Edition 3)

The following instructions apply when two or more independently controlled indoor units are installed on a single refrigeration system, along with one or more Alarm Kits as safety device. Height of room where indoor unit installed must be higher than 2.0 m (6.56 ft).

- Use the <Table 2> to determine the minimum floor area with m .
- If m is not in table, use the next larger value.
- m : Total refrigerant charge in system.
- Total refrigerant charge in system : factory refrigerant charge + additional refrigerant charge.
- A_{alarm} : Minimum floor area with alarm kit.

NOTE

- To use alarm kit as safety device, all conditions below must be satisfied
 - Use the LG Alarm Kit (Model Name : PLDCAA0S)
 - One or more alarm kits must be installed all the rooms where indoor units are installed or connected via air duct system.
- More detailed information and installation method of alarm kit are referred to in the alarm kit installation manual.

Minimum floor area for Multi-Split System with Safety Shut Off Valve (UL 60335-2-40:2019 Edition 3)

The following instructions apply when two or more independently controlled indoor units are installed on a single refrigeration system, along with one or more Safety Shut Off Valves. Safety Shut Off Valves can be used with Alarm Kits. Height of room where indoor unit installed must be higher than 2.0 m (6.56 ft).

- Minimum floor area is based on maximum releasable charge (m_{rel}), and is not related to total refrigerant charge in system (m).
- Use the <Table 2> to determine the minimum floor area with m_{rel} .
- If m_{rel} is not in table, use the next larger value.
- m_{rel} : Maximum releasable charge calculated by work sheet.
- A_{min} : minimum floor area with safety shut off valve.
- A_{alarm} : minimum floor area with safety shut off valve and alarm kit.

Calculate Maximum Releasable charge by work sheet.

Line#	Description	Releasable charge per length	x	Length*	=	Total
1	Liquid Pipe Ø 25.4 mm (1.0 inch)	0.451 kg/m (0.303 lbs/ft)	x		=	
2	Liquid Pipe Ø 22.2 mm (7/8 inch)	0.343 kg/m (0.231 lbs/ft)	x		=	
3	Liquid Pipe Ø 19.05 mm (3/4 inch)	0.248 kg/m (0.167 lbs/ft)	x		=	
4	Liquid Pipe Ø 15.88 mm (5/8 inch)	0.173 kg/m (0.116 lbs/ft)	x		=	
5	Liquid Pipe Ø 12.7 mm (1/2 inch)	0.108 kg/m (0.073 lbs/ft)	x		=	
6	Liquid Pipe Ø 9.52 mm (3/8 inch)	0.056 kg/m (0.038 lbs/ft)	x		=	
7	Liquid Pipe Ø 6.35 mm (1/4 inch)	0.021 kg/m (0.014 lbs/ft)	x		=	
8	Gas Pipe Ø 25.4 mm (1.0 inch)	0.029 kg/m (0.020 lbs/ft)	x		=	
9	Gas Pipe Ø 22.2 mm (7/8 inch)	0.022 kg/m (0.015 lbs/ft)	x		=	
10	Gas Pipe Ø 19.05 mm (3/4 inch)	0.016 kg/m (0.011 lbs/ft)	x		=	
11	Gas Pipe Ø 15.88 mm (5/8 inch)	0.011 kg/m (0.008 lbs/ft)	x		=	
12	Gas Pipe Ø 12.7 mm (1/2 inch)	0.007 kg/m (0.005 lbs/ft)	x		=	
13	Gas Pipe Ø 9.52 mm (3/8 inch)	0.004 kg/m (0.003 lbs/ft)	x		=	
14	Gas Pipe Ø 6.35 mm (1/4 inch)	0.002 kg/m (0.001 lbs/ft)	x		=	
15	Sum of releasable charge correction factor** of Indoor Units*				=	
16	Releasable charge before leak detection system activate.				=	2.652 kg (5.85 lbs)
Maximum Releasable Charge (Sum of lines 1~16)						

* All pipe and indoor units between shut off valve and next shut off valve or end of the system

** Releasable charge correction factor of Indoor Units are provided as a one-sheet manual and online Installation manual.

⚠ WARNING

- Safety shut off valves installation shall avoid hydraulic shock.
- Safety shut off valve shall be positioned to enable access for maintenance by an authorized person.
- When calculating the minimum floor room area, the releasable charge (m_{rel}) value replaces total refrigerant charge in system (m).
- The releasable charge (m_{rel}) is not related to total refrigerant charge in system(m).
- More detailed information and installation method of safety shut off valve are referred to in the safety shut off valve installation manual.

Releasable Charge Correction Factor of Indoor Units (UL 60335-2-40:2019 Edition 3)

Use the table to find releasable charge correction factor of indoor units when calculate maximum releasable charge (m_{rel}).

Unit : kg (lbs)

Model	Capacity (kBtu/h (kW))															
	5 (1.5)	7 (2.1)	9 (2.6)	12 (3.5)	15 (4.4)	18 (5.3)	24 (7)	28 (8.2)	30 (8.8)	36 (10.6)	42 (12.3)	48 (14.1)	54 (15.8)	60 (17.6)	76 (22.3)	96 (28.1)
ZRNU**3TC*A		0.63 (1.39)	0.63 (1.39)	0.63 (1.39)		0.63 (1.39)										
ZRNU**3TS*A						0.98 (2.17)	0.98 (2.17)									
ZRNU**3TR(TQ)*A	0.33 (0.73)	0.33 (0.73)	0.68 (1.5)	0.68 (1.5)	0.85 (1.88)	0.85 (1.88)										
ZRNU**3TB*A		0.75 (1.66)	0.75 (1.66)	0.75 (1.66)	0.75 (1.66)											
ZRNU**3TA*A		1.71 (3.77)	1.71 (3.77)	1.71 (3.77)	1.71 (3.77)	1.71 (3.77)	1.71 (3.77)	1.71 (3.77)		1.71 (3.77)	1.71 (3.77)					
ZRNU**3SJ(SK,SR)*A	0.38 (0.84)	0.38 (0.84)	0.38 (0.84)	0.38 (0.84)	0.38 (0.84)	1.00 (2.21)	1.00 (2.21)		1.79 (3.95)	1.79 (3.95)						
ZRNU**3L1(L2,L3)*A		0.39 (0.86)	0.39 (0.86)	0.53 (1.17)	0.53 (1.17)	0.53 (1.17)	0.67 (1.48)									
ZRNU**3MA*A		0.61 (1.35)	0.61 (1.35)	0.61 (1.35)	0.61 (1.35)	0.61 (1.35)	0.91 (2.01)									
ZRNU**3M2*A		0.81 (1.79)	0.81 (1.79)	0.81 (1.79)	0.81 (1.79)	0.81 (1.79)	0.81 (1.79)	1.22 (2.69)		1.22 (2.69)	1.22 (2.69)					
ZRNU**3M3*A								1.50 (3.31)				1.50 (3.31)	1.50 (3.31)			
ZRNU**3B8*A										2.68 (5.91)	2.68 (5.91)	2.68 (5.91)	2.68 (5.91)		2.68 (5.91)	2.68 (5.91)
ZRNU**3NA(NB,NC)*A				1.29 (2.85)		1.29 (2.85)	1.29 (2.85)		1.29 (2.85)	2.41 (5.32)	2.41 (5.32)	2.41 (5.32)	2.41 (5.32)	2.41 (5.32)		
ZRNU**3CE(CF)*A		0.47 (1.04)	0.47 (1.04)	0.47 (1.04)	0.47 (1.04)	1.00 (2.21)	1.00 (2.21)									
ZRNU**3V1(V2)*A						1.45 (3.2)	1.45 (3.2)			2.12 (4.68)		2.12 (4.68)				

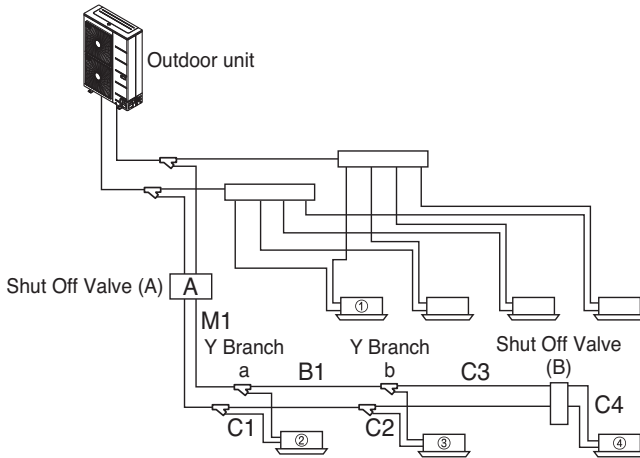
Example of Calculating m_{rel} 

Pipe No.	Pipe Name	Description	Length m (ft)	Liquid Pipe mm (inch)	Gas Pipe mm (inch)
M1	Main Pipe	Main Pipe after shut off valve (A) and before first branch (a)	10	Ø 12.7 (1/2)	Ø 22.2 (7/8)
B1	Branch Pipe	Branch Pipe after first branch (a) and before second branch (b)	10	Ø 9.52 (3/8)	Ø 15.88 (5/8)
C1	Connecting Pipe	Connecting pipe to indoor unit (2)	15	Ø 6.35 (1/4)	Ø 12.7 (1/2)
C2	Connecting Pipe	Connecting pipe to indoor unit (3)	15	Ø 6.35 (1/4)	Ø 12.7 (1/2)
C3	Connecting Pipe	Connecting pipe to indoor unit (4) before shut off valve (B)	10	Ø 6.35 (1/4)	Ø 9.52 (3/8)
C4	Connecting Pipe	Connecting pipe to indoor unit (4) after shut off valve (B)	5	Ø 6.35 (1/4)	Ø 9.52 (3/8)

Case 1 : Indoor units with out shut off valve. (Indoor Unit ①)

Without shut off valve, Use the <Table 2> to determine A_{min} or A_{alarm} (if applicable) with m .

Case 2 : Indoor units between shut off valve and next shut off valve. (Indoor Unit ②, ③)

Line#	Description	Releasable charge per length	x	Length*	=	Total
1	Liquid Pipe Ø 25.4 mm (1.0 inch)	0.451 kg/m (0.303 lbs/ft)	x		=	
2	Liquid Pipe Ø 22.2 mm (7/8 inch)	0.343 kg/m (0.231 lbs/ft)	x		=	
3	Liquid Pipe Ø 19.05 mm (3/4 inch)	0.248 kg/m (0.167 lbs/ft)	x		=	
4	Liquid Pipe Ø 15.88 mm (5/8 inch)	0.173 kg/m (0.116 lbs/ft)	x		=	
5	Liquid Pipe Ø 12.7 mm (1/2 inch)	0.108 kg/m (0.073 lbs/ft)	x	10 m (32.81 ft)	=	1.08 kg (2.4 lbs)
6	Liquid Pipe Ø 9.52 mm (3/8 inch)	0.056 kg/m (0.038 lbs/ft)	x	10 m (32.81 ft)	=	0.56 kg (1.25 lbs)
7	Liquid Pipe Ø 6.35 mm (1/4 inch)	0.021 kg/m (0.014 lbs/ft)	x	40 m (131.23 ft)	=	0.84 kg (1.84 lbs)
8	Gas Pipe Ø 25.4 mm (1.0 inch)	0.029 kg/m (0.020 lbs/ft)	x		=	
9	Gas Pipe Ø 22.2 mm (7/8 inch)	0.022 kg/m (0.015 lbs/ft)	x	10 m (32.81 ft)	=	0.22 kg (0.49 lbs)
10	Gas Pipe Ø 19.05 mm (3/4 inch)	0.016 kg/m (0.011 lbs/ft)	x		=	
11	Gas Pipe Ø 15.88 mm (5/8 inch)	0.011 kg/m (0.008 lbs/ft)	x	10 m (32.81 ft)	=	0.11 kg (0.26 lbs)
12	Gas Pipe Ø 12.7 mm (1/2 inch)	0.007 kg/m (0.005 lbs/ft)	x	30 m (98.43 ft)	=	0.21 kg (0.49 lbs)
13	Gas Pipe Ø 9.52 mm (3/8 inch)	0.004 kg/m (0.003 lbs/ft)	x	10 m (32.81 ft)	=	0.04 kg (0.1 lbs)
14	Gas Pipe Ø 6.35 mm (1/4 inch)	0.002 kg/m (0.001 lbs/ft)	x		=	
15	Sum of releasable charge correction factor** of Indoor Units				=	3.42 kg (7.54 lbs)
16	Releasable charge before leak detection system activate.				=	2.652 kg (5.85 lbs)
Maximum Releasable Charge (Sum of lines 1~16)					=	9.13 kg (20.22 lbs)

*Sum of all pipe (M1, B1, C1, C2, C3) length between shut off valve (A) and shut off valve (B)

**TM-A CST 2 EA (②, ③) : 1.71 kg (3.77 lbs) / EA * 2 EA = 3.42 kg (7.54 lbs)

Use the <Table 2> to determine A_{min} or A_{alarm} (if applicable) with m_{rel} calculated by work sheet

Case 3 : Indoor units between shut off valve and end of system. (Indoor Unit ④)

Line#	Description	Releasable charge per length	x	Length*	=	Total
1	Liquid Pipe Ø 25.4 mm (1.0 inch)	0.451 kg/m (0.303 lbs/ft)	x		=	
2	Liquid Pipe Ø 22.2 mm (7/8 inch)	0.343 kg/m (0.231 lbs/ft)	x		=	
3	Liquid Pipe Ø 19.05 mm (3/4 inch)	0.248 kg/m (0.167 lbs/ft)	x		=	
4	Liquid Pipe Ø 15.88 mm (5/8 inch)	0.173 kg/m (0.116 lbs/ft)	x		=	
5	Liquid Pipe Ø 12.7 mm (1/2 inch)	0.108 kg/m (0.073 lbs/ft)	x		=	
6	Liquid Pipe Ø 9.52 mm (3/8 inch)	0.056 kg/m (0.038 lbs/ft)	x		=	
7	Liquid Pipe Ø 6.35 mm (1/4 inch)	0.021 kg/m (0.014 lbs/ft)	x	5 m (16.4 ft)	=	0.11 kg (0.23 lbs)
8	Gas Pipe Ø 25.4 mm (1.0 inch)	0.029 kg/m (0.020 lbs/ft)	x		=	
9	Gas Pipe Ø 22.2 mm (7/8 inch)	0.022 kg/m (0.015 lbs/ft)	x		=	
10	Gas Pipe Ø 19.05 mm (3/4 inch)	0.016 kg/m (0.011 lbs/ft)	x		=	
11	Gas Pipe Ø 15.88 mm (5/8 inch)	0.011 kg/m (0.008 lbs/ft)	x		=	
12	Gas Pipe Ø 12.7 mm (1/2 inch)	0.007 kg/m (0.005 lbs/ft)	x		=	
13	Gas Pipe Ø 9.52 mm (3/8 inch)	0.004 kg/m (0.003 lbs/ft)	x	5 m (16.4 ft)	=	0.02 kg (0.05 lbs)
14	Gas Pipe Ø 6.35 mm (1/4 inch)	0.002 kg/m (0.001 lbs/ft)	x		=	
15	Sum of releasable charge correction factor** of Indoor Units				=	1.71 kg (3.77 lbs)
16	Releasable charge before leak detection system activate.				=	2.652 kg (5.85 lbs)
Maximum Releasable Charge (Sum of lines 1~16)						4.49 kg (9.9 lbs)

*Sum of all pipe (C4) length after shut off valve (B) and end of system.

**TM-A CST 1 EA (④) : 1.71 kg (3.77 lbs) / EA * 1 EA = 1.71 kg (3.77 lbs)

Use the <Table 2> to determine A_{min} or A_{alarm} (if applicable) with m_{rel} calculated by work sheet

<Table 2> : Table for Multi-Split System

Maximum of m or m_{rel} is product of 15.91 kg (35.07 lbs) and Number of Indoor units, not exceed 63.64 kg (140.30 lbs)

* A_{alarm} only applies for indoor units with one or more alarm kits as safety device.

* m_{rel} is calculated value with work sheet when one or more shut off valves are used.

* The releasable charge (m_{rel}) is not related to total refrigerant charge in system (m).

Minimum floor area					
m or m _{rel}		A _{min}		A _{alarm}	
kg	lbs	m ²	ft ²	m ²	ft ²
≤ 1.83	≤ 4.04	-	-	-	-
1.85	4.07	12.10	130.25	6.05	65.13
2.00	4.40	13.08	140.80	6.54	70.40
2.20	4.85	14.38	154.79	7.19	77.40
2.40	5.29	15.69	168.89	7.85	84.50
2.60	5.73	17.00	182.99	8.50	91.50
2.80	6.17	18.31	197.09	9.16	98.60
3.00	6.61	19.61	211.09	9.81	105.60
3.20	7.05	20.92	225.19	10.46	112.60
3.40	7.49	22.23	239.29	11.12	119.70
3.60	7.93	23.53	253.28	11.77	126.70
3.80	8.37	24.84	267.38	12.42	133.69
4.00	8.81	26.15	281.48	13.08	140.80
4.20	9.25	27.46	295.58	13.73	147.79
4.40	9.70	28.76	309.58	14.38	154.79
4.60	10.14	30.07	323.68	15.04	161.89
4.80	10.58	31.38	337.78	15.69	168.89
5.00	11.02	32.68	351.77	16.34	175.89
5.20	11.46	33.99	365.87	17.00	182.99
5.40	11.90	35.30	379.97	17.65	189.99
5.60	12.34	36.61	394.07	18.31	197.09
5.80	12.78	37.91	408.06	18.96	204.09
6.00	13.22	39.22	422.17	19.61	211.09
6.20	13.66	40.53	436.27	20.27	218.19
6.40	14.10	41.84	450.37	20.92	225.19
6.60	14.55	43.14	464.36	21.57	232.18
6.80	14.99	44.45	478.46	22.23	239.29
7.00	15.43	45.76	492.56	22.88	246.28
7.20	15.87	47.06	506.55	23.53	253.28
7.40	16.31	48.37	520.66	24.19	260.38
7.60	16.75	49.68	534.76	24.84	267.38
7.80	17.19	50.99	548.86	25.50	274.48
8.00	17.63	52.29	562.85	26.15	281.48
8.20	18.07	53.60	576.95	26.80	288.48
8.40	18.51	54.91	591.05	27.46	295.58
8.60	18.95	56.21	605.04	28.11	302.58
8.80	19.40	57.52	619.15	28.76	309.58
9.00	19.84	58.83	633.25	29.42	316.68
9.20	20.28	60.14	647.35	30.07	323.68
9.40	20.72	61.44	661.34	30.72	330.67
9.60	21.16	62.75	675.44	31.38	337.78
9.80	21.60	64.06	689.54	32.03	344.77
10.00	22.04	65.36	703.53	32.68	351.77
10.20	22.48	66.67	717.63	33.34	358.77
10.40	22.92	67.98	731.74	33.99	365.87
10.60	23.36	69.29	745.84	34.65	372.97
10.80	23.80	70.59	759.83	35.30	379.97
11.00	24.25	71.90	773.93	35.95	386.97
11.20	24.69	73.21	788.03	36.61	394.07

Minimum floor area					
m or m _{rel}		A _{min}		A _{alarm}	
kg	lbs	m ²	ft ²	m ²	ft ²
11.40	25.13	74.51	802.02	37.26	401.07
11.60	25.57	75.82	816.12	37.91	408.06
11.80	26.01	77.13	830.23	38.57	415.17
12.00	26.45	78.44	844.33	39.22	422.17
12.20	26.89	79.74	858.32	39.87	429.16
12.40	27.33	81.05	872.42	40.53	436.27
12.60	27.77	82.36	886.52	41.18	443.26
12.80	28.21	83.67	900.62	41.84	450.37
13.00	28.66	84.97	914.61	42.49	457.36
13.20	29.10	86.28	928.72	43.14	464.36
13.40	29.54	87.59	942.82	43.80	471.46
13.60	29.98	88.89	956.81	44.45	478.46
13.80	30.42	90.20	970.91	45.10	485.46
14.00	30.86	91.51	985.01	45.76	492.56
14.20	31.30	92.82	999.11	46.41	499.56
14.40	31.74	94.12	1013.10	47.06	506.55
14.60	32.18	95.43	1027.20	47.72	513.66
14.80	32.62	96.74	1041.31	48.37	520.66
15.00	33.06	98.04	1055.30	49.02	527.65
15.20	33.51	99.35	1069.40	49.68	534.76
15.40	33.95	100.66	1083.50	50.33	541.75
15.60	34.39	101.97	1097.60	50.99	548.86
15.80	34.83	103.27	1111.59	51.64	555.85
16.00	35.27	104.58	1125.69	52.29	562.85
16.20	35.71	105.89	1139.80	52.95	569.95
16.40	36.15	107.19	1153.79	53.60	576.95
16.60	36.59	108.50	1167.89	54.25	583.95
16.80	37.03	109.81	1181.99	54.91	591.05
17.00	37.47	111.12	1196.09	55.56	598.05
17.20	37.91	112.42	1210.08	56.21	605.04
17.40	38.36	113.73	1224.18	56.87	612.15
17.60	38.80	115.04	1238.29	57.52	619.15
17.80	39.24	116.34	1252.28	58.17	626.14
18.00	39.68	117.65	1266.38	58.83	633.25
18.20	40.12	118.96	1280.48	59.48	640.24
18.40	40.56	120.27	1294.58	60.14	647.35
18.60	41.00	121.57	1308.57	60.79	654.34
18.80	41.44	122.88	1322.67	61.44	661.34
19.00	41.88	124.19	1336.78	62.10	668.44
19.20	42.32	125.50	1350.88	62.75	675.44
19.40	42.76	126.80	1364.87	63.40	682.44
19.60	43.21	128.11	1378.97	64.06	689.54
19.80	43.65	129.42	1393.07	64.71	696.54
20.00	44.09	130.72	1407.06	65.36	703.53
20.20	44.53	132.03	1421.16	66.02	710.64
20.40	44.97	133.34	1435.26	66.67	717.63
20.60	45.41	134.65	1449.37	67.33	724.74
20.80	45.85	135.95	1463.36	67.98	731.74
21.00	46.29	137.26	1477.46	68.63	738.73

Minimum floor area					
m or m _{rel}		A _{min}		A _{alarm}	
kg	lbs	m ²	ft ²	m ²	ft ²
21.20	46.73	138.57	1491.56	69.29	745.84
21.40	47.17	139.87	1505.55	69.94	752.83
21.60	47.61	141.18	1519.65	70.59	759.83
21.80	48.06	142.49	1533.75	71.25	766.93
22.00	48.50	143.80	1547.86	71.90	773.93
22.20	48.94	145.10	1561.85	72.55	780.93
22.40	49.38	146.41	1575.95	73.21	788.03
22.60	49.82	147.72	1590.05	73.86	795.03
22.80	50.26	149.02	1604.04	74.51	802.02
23.00	50.70	150.33	1618.14	75.17	809.13
23.20	51.14	151.64	1632.24	75.82	816.12
23.40	51.58	152.95	1646.35	76.48	823.23
23.60	52.02	154.25	1660.34	77.13	830.23
23.80	52.47	155.56	1674.44	77.78	837.22
24.00	52.91	156.87	1688.54	78.44	844.33
24.20	53.35	158.17	1702.53	79.09	851.32
24.40	53.79	159.48	1716.63	79.74	858.32
24.60	54.23	160.79	1730.73	80.40	865.42
24.80	54.67	162.10	1744.83	81.05	872.42
25.00	55.11	163.40	1758.83	81.70	879.42
25.20	55.55	164.71	1772.93	82.36	886.52
25.40	55.99	166.02	1787.03	83.01	893.52
25.60	56.43	167.33	1801.13	83.67	900.62
25.80	56.87	168.63	1815.12	84.32	907.62
26.00	57.32	169.94	1829.22	84.97	914.61
26.20	57.76	171.25	1843.32	85.63	921.72
26.40	58.20	172.55	1857.32	86.28	928.72
26.60	58.64	173.86	1871.42	86.93	935.71
26.80	59.08	175.17	1885.52	87.59	942.82
27.00	59.52	176.48	1899.62	88.24	949.81
27.20	59.96	177.78	1913.61	88.89	956.81
27.40	60.40	179.09	1927.71	89.55	963.91
27.60	60.84	180.40	1941.81	90.20	970.91
27.80	61.28	181.70	1955.81	90.85	977.91
28.00	61.72	183.01	1969.91	91.51	985.01
28.20	62.17	184.32	1984.01	92.16	992.01
28.40	62.61	185.63	1998.11	92.82	999.11
28.60	63.05	186.93	2012.10	93.47	1006.11
28.80	63.49	188.24	2026.20	94.12	1013.10
29.00	63.93	189.55	2040.30	94.78	1020.21
29.20	64.37	190.85	2054.30	95.43	1027.20
29.40	64.81	192.16	2068.40	96.08	1034.20
29.60	65.25	193.47	2082.50	96.74	1041.31
29.80	65.69	194.78	2096.60	97.39	1048.30
30.00	66.13	196.08	2110.59	98.04	1055.30
30.20	66.57	197.39	2124.69	98.70	1062.40
30.40	67.02	198.70	2138.79	99.35	1069.40
30.60	67.46	200.00	2152.79	100.00	1076.40
30.80	67.90	201.31	2166.89	100.66	1083.50
31.00	68.34	202.62	2180.99	101.31	1090.50
31.20	68.78	203.93	2195.09	101.97	1097.60
31.40	69.22	205.23	2209.08	102.62	1104.60
31.60	69.66	206.54	2223.18	103.27	1111.59
31.80	70.10	207.85	2237.28	103.93	1118.70

Minimum floor area					
m or m _{rel}		A _{min}		A _{alarm}	
kg	lbs	m ²	ft ²	m ²	ft ²
32.00	70.54	209.16	2251.38	104.58	1125.69
32.20	70.98	210.46	2265.38	105.23	1132.69
32.40	71.42	211.77	2279.48	105.89	1139.80
32.60	71.87	213.08	2293.58	106.54	1146.79
32.80	72.31	214.38	2307.57	107.19	1153.79
33.00	72.75	215.69	2321.67	107.85	1160.89
33.20	73.19	217.00	2335.77	108.50	1167.89
33.40	73.63	218.31	2349.87	109.16	1174.99
33.60	74.07	219.61	2363.87	109.81	1181.99
33.80	74.51	220.92	2377.97	110.46	1188.99
34.00	74.95	222.23	2392.07	111.12	1196.09
34.20	75.39	223.53	2406.06	111.77	1203.09
34.40	75.83	224.84	2420.16	112.42	1210.08
34.60	76.27	226.15	2434.26	113.08	1217.19
34.80	76.72	227.46	2448.36	113.73	1224.18
35.00	77.16	228.76	2462.36	114.38	1231.18
35.20	77.60	230.07	2476.46	115.04	1238.29
35.40	78.04	231.38	2490.56	115.69	1245.28
35.60	78.48	232.68	2504.55	116.34	1252.28
35.80	78.92	233.99	2518.65	117.00	1259.38
36.00	79.36	235.30	2532.75	117.65	1266.38
36.20	79.80	236.61	2546.85	118.31	1273.48
36.40	80.24	237.91	2560.85	118.96	1280.48
36.60	80.68	239.22	2574.95	119.61	1287.48
36.80	81.13	240.53	2589.05	120.27	1294.58
37.00	81.57	241.84	2603.15	120.92	1301.58
37.20	82.01	243.14	2617.14	121.57	1308.57
37.40	82.45	244.45	2631.24	122.23	1315.68
37.60	82.89	245.76	2645.34	122.88	1322.67
37.80	83.33	247.06	2659.34	123.53	1329.67
38.00	83.77	248.37	2673.44	124.19	1336.78
38.20	84.21	249.68	2687.54	124.84	1343.77
38.40	84.65	250.99	2701.64	125.50	1350.88
38.60	85.09	252.29	2715.63	126.15	1357.87
38.80	85.53	253.60	2729.73	126.80	1364.87
39.00	85.98	254.91	2743.83	127.46	1371.97
39.20	86.42	256.21	2757.83	128.11	1378.97
39.40	86.86	257.52	2771.93	128.76	1385.97
39.60	87.30	258.83	2786.03	129.42	1393.07
39.80	87.74	260.14	2800.13	130.07	1400.07
40.00	88.18	261.44	2814.12	130.72	1407.06
40.20	88.62	262.75	2828.22	131.38	1414.17
40.40	89.06	264.06	2842.32	132.03	1421.16
40.60	89.50	265.36	2856.32	132.68	1428.16
40.80	89.94	266.67	2870.42	133.34	1435.26
41.00	90.38	267.98	2884.52	133.99	1442.26
41.20	90.83	269.29	2898.62	134.65	1449.37
41.40	91.27	270.59	2912.61	135.30	1456.36
41.60	91.71	271.90	2926.71	135.95	1463.36
41.80	92.15	273.21	2940.81	136.61	1470.46
42.00	92.59	274.51	2954.81	137.26	1477.46
42.20	93.03	275.82	2968.91	137.91	1484.46
42.40	93.47	277.13	2983.01	138.57	1491.56
42.60	93.91	278.44	2997.11	139.22	1498.56

Cassette Indoor Units Installation General Information

Minimum floor area					
m or m _{rel}		A _{min}		A _{alarm}	
kg	lbs	m ²	ft ²	m ²	ft ²
42.80	94.35	279.74	3011.10	139.87	1505.55
43.00	94.79	281.05	3025.20	140.53	1512.66
43.20	95.23	282.36	3039.30	141.18	1519.65
43.40	95.68	283.67	3053.40	141.84	1526.76
43.60	96.12	284.97	3067.40	142.49	1533.75
43.80	96.56	286.28	3081.50	143.14	1540.75
44.00	97.00	287.59	3095.60	143.80	1547.86
44.20	97.44	288.89	3109.59	144.45	1554.85
44.40	97.88	290.20	3123.69	145.10	1561.85
44.60	98.32	291.51	3137.79	145.76	1568.95
44.80	98.76	292.82	3151.89	146.41	1575.95
45.00	99.20	294.12	3165.89	147.06	1582.95
45.20	99.64	295.43	3179.99	147.72	1590.05
45.40	100.08	296.74	3194.09	148.37	1597.05
45.60	100.53	298.04	3208.08	149.02	1604.04
45.80	100.97	299.35	3222.18	149.68	1611.15
46.00	101.41	300.66	3236.28	150.33	1618.14
46.20	101.85	301.97	3250.38	150.99	1625.25
46.40	102.29	303.27	3264.38	151.64	1632.24
46.60	102.73	304.58	3278.48	152.29	1639.24
46.80	103.17	305.89	3292.58	152.95	1646.35
47.00	103.61	307.19	3306.57	153.60	1653.34
47.20	104.05	308.50	3320.67	154.25	1660.34
47.40	104.49	309.81	3334.77	154.91	1667.44
47.60	104.94	311.12	3348.87	155.56	1674.44
47.80	105.38	312.42	3362.87	156.21	1681.44
48.00	105.82	313.73	3376.97	156.87	1688.54
48.20	106.26	315.04	3391.07	157.52	1695.54
48.40	106.70	316.34	3405.06	158.17	1702.53
48.60	107.14	317.65	3419.16	158.83	1709.64
48.80	107.58	318.96	3433.26	159.48	1716.63
49.00	108.02	320.27	3447.36	160.14	1723.74
49.20	108.46	321.57	3461.36	160.79	1730.73
49.40	108.90	322.88	3475.46	161.44	1737.73
49.60	109.34	324.19	3489.56	162.10	1744.83
49.80	109.79	325.50	3503.66	162.75	1751.83
50.00	110.23	326.80	3517.65	163.40	1758.83
50.20	110.67	328.11	3531.75	164.06	1765.93
50.40	111.11	329.42	3545.85	164.71	1772.93
50.60	111.55	330.72	3559.85	165.36	1779.93
50.80	111.99	332.03	3573.95	166.02	1787.03
51.00	112.43	333.34	3588.05	166.67	1794.03
51.20	112.87	334.65	3602.15	167.33	1801.13
51.40	113.31	335.95	3616.14	167.98	1808.13
51.60	113.75	337.26	3630.24	168.63	1815.12
51.80	114.19	338.57	3644.34	169.29	1822.23
52.00	114.64	339.87	3658.34	169.94	1829.22
52.20	115.08	341.18	3672.44	170.59	1836.22
52.40	115.52	342.49	3686.54	171.25	1843.32
52.60	115.96	343.80	3700.64	171.90	1850.32
52.80	116.40	345.10	3714.63	172.55	1857.32
53.00	116.84	346.41	3728.73	173.21	1864.42
53.20	117.28	347.72	3742.83	173.86	1871.42
53.40	117.72	349.02	3756.83	174.51	1878.42

Minimum floor area					
m or m _{rel}		A _{min}		A _{alarm}	
kg	lbs	m ²	ft ²	m ²	ft ²
53.60	118.16	350.33	3770.93	175.17	1885.52
53.80	118.60	351.64	3785.03	175.82	1892.52
54.00	119.04	352.95	3799.13	176.48	1899.62
54.20	119.49	354.25	3813.12	177.13	1906.62
54.40	119.93	355.56	3827.22	177.78	1913.61
54.60	120.37	356.87	3841.32	178.44	1920.72
54.80	120.81	358.17	3855.31	179.09	1927.71
55.00	121.25	359.48	3869.42	179.74	1934.71
55.20	121.69	360.79	3883.52	180.40	1941.81
55.40	122.13	362.10	3897.62	181.05	1948.81
55.60	122.57	363.40	3911.61	181.70	1955.81
55.80	123.01	364.71	3925.71	182.36	1962.91
56.00	123.45	366.02	3939.81	183.01	1969.91
56.20	123.89	367.33	3953.91	183.67	1977.01
56.40	124.34	368.63	3967.91	184.32	1984.01
56.60	124.78	369.94	3982.01	184.97	1991.01
56.80	125.22	371.25	3996.11	185.63	1998.11
57.00	125.66	372.55	4010.10	186.28	2005.11
57.20	126.10	373.86	4024.20	186.93	2012.10
57.40	126.54	375.17	4038.30	187.59	2019.21
57.60	126.98	376.48	4052.40	188.24	2026.20
57.80	127.42	377.78	4066.40	188.89	2033.20
58.00	127.86	379.09	4080.50	189.55	2040.30
58.20	128.30	380.40	4094.60	190.20	2047.30
58.40	128.74	381.70	4108.59	190.85	2054.30
58.60	129.19	383.01	4122.69	191.51	2061.40
58.80	129.63	384.32	4136.79	192.16	2068.40
59.00	130.07	385.63	4150.89	192.82	2075.50
59.20	130.51	386.93	4164.88	193.47	2082.50
59.40	130.95	388.24	4178.99	194.12	2089.50
59.60	131.39	389.55	4193.09	194.78	2096.60
59.80	131.83	390.85	4207.08	195.43	2103.60
60.00	132.27	392.16	4221.18	196.08	2110.59
60.20	132.71	393.47	4235.28	196.74	2117.70
60.40	133.15	394.78	4249.38	197.39	2124.69
60.60	133.60	396.08	4263.37	198.04	2131.69
60.80	134.04	397.39	4277.48	198.70	2138.79
61.00	134.48	398.70	4291.58	199.35	2145.79
61.20	134.92	400.00	4305.57	200.00	2152.79
61.40	135.36	401.31	4319.67	200.66	2159.89
61.60	135.80	402.62	4333.77	201.31	2166.89
61.80	136.24	403.93	4347.87	201.97	2173.99
62.00	136.68	405.23	4361.86	202.62	2180.99
62.20	137.12	406.54	4375.97	203.27	2187.99
62.40	137.56	407.85	4390.07	203.93	2195.09
62.60	138.00	409.16	4404.17	204.58	2202.09
62.80	138.45	410.46	4418.16	205.23	2209.08
63.00	138.89	411.77	4432.26	205.89	2216.19
63.20	139.33	413.08	4446.36	206.54	2223.18
63.40	139.77	414.38	4460.35	207.19	2230.18
63.60	140.21	415.69	4474.45	207.85	2237.28
63.64	140.30	415.95	4477.25	207.98	2238.68

Minimum floor area for ETRS unit (UL 60335-2-40:2022 Edition 4)

The following instructions apply to appliance marked "ETRS" on the nameplate (enhanced tightness refrigerating systems). Height of room where indoor units are installed must be higher than 2.0 m (6.56 ft).

- Use the <Table 3> to determine the minimum floor area with m .
- If m is not in table, use the next larger value.
- m : Total refrigerant charge in system
- Total refrigerant charge in system : factory refrigerant charge +additional refrigerant charge.
- A_{min} : minimum floor area.

Minimum floor area for ETRS unit with Safety Shut Off Valve (UL 60335-2-40:2022 Edition 4)

The following instructions apply to ERTS Unit with one or more Safety Shut Off Valves.

Height of room where indoor unit installed must be higher than 2.0 m (6.56 ft).

- Minimum floor area is based on maximum releasable charge (m_{rel}), and is not related to total refrigerant charge in system (m).
- Use the <Table 3> to determine the minimum floor area with m_{rel}
- If m_{rel} is not in table, use the next larger value.
- m_{rel} : Maximum releasable charge calculated by work sheet.
- A_{min} : minimum floor area with safety shut off valve.

Calculate Maximum Releasable charge by work sheet.

Line#	Description	Releasable charge per length	x	Length*	=	Total
1	Liquid Pipe Ø 25.4 mm (1.0 inch)	0.376 kg/m (0.253 lbs/ft)	x		=	
2	Liquid Pipe Ø 22.2 mm (7/8 inch)	0.286 kg/m (0.193 lbs/ft)	x		=	
3	Liquid Pipe Ø 19.05 mm (3/4 inch)	0.207 kg/m (0.139 lbs/ft)	x		=	
4	Liquid Pipe Ø 15.88 mm (5/8 inch)	0.144 kg/m (0.097 lbs/ft)	x		=	
5	Liquid Pipe Ø 12.7 mm (1/2 inch)	0.090 kg/m (0.061 lbs/ft)	x		=	
6	Liquid Pipe Ø 9.52 mm (3/8 inch)	0.047 kg/m (0.032 lbs/ft)	x		=	
7	Liquid Pipe Ø 6.35 mm (1/4 inch)	0.018 kg/m (0.012 lbs/ft)	x		=	
8	Gas Pipe Ø 25.4 mm (1.0 inch)	0.030 kg/m (0.020 lbs/ft)	x		=	
9	Gas Pipe Ø 22.2 mm (7/8 inch)	0.023 kg/m (0.015 lbs/ft)	x		=	
10	Gas Pipe Ø 19.05 mm (3/4 inch)	0.016 kg/m (0.011 lbs/ft)	x		=	
11	Gas Pipe Ø 15.88 mm (5/8 inch)	0.012 kg/m (0.008 lbs/ft)	x		=	
12	Gas Pipe Ø 12.7 mm (1/2 inch)	0.007 kg/m (0.005 lbs/ft)	x		=	
13	Gas Pipe Ø 9.52 mm (3/8 inch)	0.004 kg/m (0.003 lbs/ft)	x		=	
14	Gas Pipe Ø 6.35 mm (1/4 inch)	0.002 kg/m (0.001 lbs/ft)	x		=	
15	Sum of releasable charge correction factor** of Indoor Units*				=	
16	Releasable charge before leak detection system activate.				=	0.204 kg (0.45 lbs)
Maximum Releasable Charge (Sum of lines 1~16)						

* All pipe and indoor units between shut off valve and next shut off valve or end of the system

** Releasable charge correction factor of Indoor Units are provided as a one-sheet manual and online Installation manual.

⚠ WARNING

- Safety shut off valves installation shall avoid hydraulic shock.
- Safety shut off valve shall be positioned to enable access for maintenance by an authorized person.
- When calculating the minimum floor room area, the releasable charge (m_{rel}) value replaces total refrigerant charge in system (m).
- The releasable charge (m_{rel}) is not related to total refrigerant charge in system(m).
- More detailed information and installation method of safety shut off valve are referred to in the safety shut off valve installation manual.

Releasable Charge Correction Factor of Indoor Units (UL 60335-2-40:2022 Edition 4)

Use the table to find releasable charge correction factor of indoor units when calculate maximum releasable charge(m_{rel}).

Unit : kg (lbs)

Model	Capacity (kBtu/h (kW))															
	5 (1.5)	7 (2.1)	9 (2.6)	12 (3.5)	15 (4.4)	18 (5.3)	24 (7)	28 (8.2)	30 (8.8)	36 (10.6)	42 (12.3)	48 (14.1)	54 (15.8)	60 (17.6)	76 (22.3)	96 (28.1)
ZRNU**3TC*A		0.25 (0.56)	0.25 (0.56)	0.25 (0.56)		0.25 (0.56)										
ZRNU**3TS*A						0.38 (0.84)	0.38 (0.84)									
ZRNU**3TR(TQ)*A	0.13 (0.29)	0.13 (0.29)	0.27 (0.6)	0.27 (0.6)	0.33 (0.73)	0.33 (0.73)										
ZRNU**3TB*A		0.30 (1.66)	0.30 (1.66)	0.30 (1.66)	0.30 (1.66)											
ZRNU**3TA*A		0.67 (1.48)	0.67 (1.48)	0.67 (1.48)	0.67 (1.48)	0.67 (1.48)	0.67 (1.48)	0.67 (1.48)		0.67 (1.48)	0.67 (1.48)					
ZRNU**3SJ(SK,SR)*A	0.15 (0.34)	0.15 (0.34)	0.15 (0.34)	0.15 (0.34)	0.15 (0.34)	0.39 (1.86)	0.39 (1.86)		0.70 (1.55)	0.70 (1.55)						
ZRNU**3L1(L2,L3)*A		0.16 (0.36)	0.16 (0.36)	0.21 (0.47)	0.21 (0.47)	0.21 (0.47)	0.26 (0.58)									
ZRNU**3MA*A		0.24 (0.53)	0.24 (0.53)	0.24 (0.53)	0.24 (0.53)	0.24 (0.53)	0.36 (0.8)									
ZRNU**3M2*A		0.32 (0.71)	0.32 (0.71)	0.32 (0.71)	0.32 (0.71)	0.32 (0.71)	0.32 (0.71)	0.48 (1.06)		0.48 (1.06)	0.48 (1.06)					
ZRNU**3M3*A								0.59 (1.31)				0.59 (1.31)	0.59 (1.31)			
ZRNU**3B8*A										1.05 (2.32)	1.05 (2.32)	1.05 (2.32)	1.05 (2.32)		1.05 (2.32)	1.05 (2.32)
ZRNU**3NA(NB,NC)*A				0.51 (1.13)		0.51 (1.13)	0.51 (1.13)		0.51 (1.13)	0.94 (2.08)	0.94 (2.08)	0.94 (2.08)	0.94 (2.08)	0.94 (2.08)		
ZRNU**3CE(CF)*A		0.19 (0.42)	0.19 (0.42)	0.19 (0.42)	0.19 (0.42)	0.39 (1.86)	0.39 (1.86)									
ZRNU**3V1(V2)*A						0.57 (1.26)	0.57 (1.26)			0.83 (2.83)		0.83 (2.83)				

Example of Calculating m_{rel}

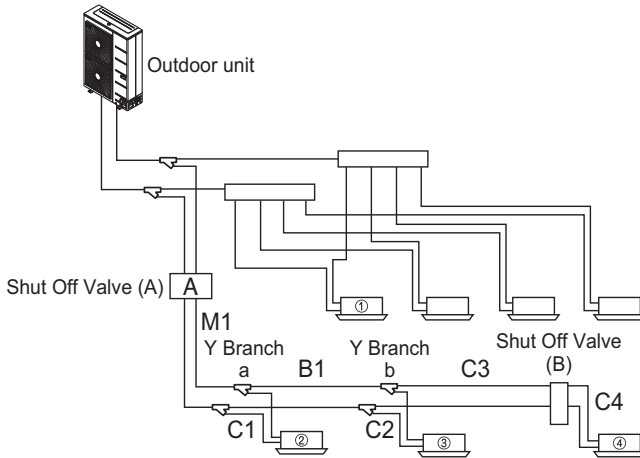

Pipe No.	Pipe Name	Description	Length m (ft)	Liquid Pipe mm (inch)	Gas Pipe mm (inch)
M1	Main Pipe	Main Pipe after shut off valve (A) and before first branch (a)	10	Ø 12.7 (1/2)	Ø 22.2 (7/8)
B1	Branch Pipe	Branch Pipe after first branch (a) and before second branch (b)	10	Ø 9.52 (3/8)	Ø 15.88 (5/8)
C1	Connecting Pipe	Connecting pipe to indoor unit (2)	15	Ø 6.35 (1/4)	Ø 12.7 (1/2)
C2	Connecting Pipe	Connecting pipe to indoor unit (3)	15	Ø 6.35 (1/4)	Ø 12.7 (1/2)
C3	Connecting Pipe	Connecting pipe to indoor unit (4) before shut off valve (B)	10	Ø 6.35 (1/4)	Ø 9.52 (3/8)
C4	Connecting Pipe	Connecting pipe to indoor unit (4) after shut off valve (B)	5	Ø 6.35 (1/4)	Ø 9.52 (3/8)

Case 1 : Indoor units with out shut off valve. (Indoor Unit ①)

Without shut off valve, Use the <Table 3> to determine A_{min} with m .

Case 2 : Indoor units between shut off valve and next shut off valve. (Indoor Unit ②, ③)

Line#	Description	Releasable charge per length	x	Length*	=	Total
1	Liquid Pipe Ø 25.4 mm (1.0 inch)	0.376 kg/m (0.253 lbs/ft)	x		=	
2	Liquid Pipe Ø 22.2 mm (7/8 inch)	0.286 kg/m (0.193 lbs/ft)	x		=	
3	Liquid Pipe Ø 19.05 mm (3/4 inch)	0.207 kg/m (0.139 lbs/ft)	x		=	
4	Liquid Pipe Ø 15.88 mm (5/8 inch)	0.144 kg/m (0.097 lbs/ft)	x		=	
5	Liquid Pipe Ø 12.7 mm (1/2 inch)	0.090 kg/m (0.061 lbs/ft)	x	10 m (32.81 ft)	=	0.9 kg (2 lbs)
6	Liquid Pipe Ø 9.52 mm (3/8 inch)	0.047 kg/m (0.032 lbs/ft)	x	10 m (32.81 ft)	=	0.47 kg (1.05 lbs)
7	Liquid Pipe Ø 6.35 mm (1/4 inch)	0.018 kg/m (0.012 lbs/ft)	x	40 m (131.23 ft)	=	0.72 kg (1.57 lbs)
8	Gas Pipe Ø 25.4 mm (1.0 inch)	0.030 kg/m (0.020 lbs/ft)	x		=	
9	Gas Pipe Ø 22.2 mm (7/8 inch)	0.023 kg/m (0.015 lbs/ft)	x	10 m (32.81 ft)	=	0.23 kg (0.49 lbs)
10	Gas Pipe Ø 19.05 mm (3/4 inch)	0.016 kg/m (0.011 lbs/ft)	x		=	
11	Gas Pipe Ø 15.88 mm (5/8 inch)	0.012 kg/m (0.008 lbs/ft)	x	10 m (32.81 ft)	=	0.12 kg (0.26 lbs)
12	Gas Pipe Ø 12.7 mm (1/2 inch)	0.007 kg/m (0.005 lbs/ft)	x	30 m (98.43 ft)	=	0.21 kg (0.49 lbs)
13	Gas Pipe Ø 9.52 mm (3/8 inch)	0.004 kg/m (0.003 lbs/ft)	x	10 m (32.81 ft)	=	0.04 kg (0.1 lbs)
14	Gas Pipe Ø 6.35 mm (1/4 inch)	0.002 kg/m (0.001 lbs/ft)	x		=	
15	Sum of releasable charge correction factor** of Indoor Units				=	1.34 kg (2.96 lbs)
16	Releasable charge before leak detection system activate.				=	0.204 kg (0.45 lbs)
Maximum Releasable Charge (Sum of lines 1~16)						4.23 kg (9.37 lbs)

*Sum of all pipe (M1,B1,C1,C2,C3) length between shut off valve (A) and shut off valve (B)

**TM-A CST 2EA (②, ③) : 0.67 kg (1.48 lbs) / EA * 2 EA = 1.34 kg (2.96 lbs)

Use the <Table 3> to determine A_{\min} with m_{rel} calculated by work sheet

Case 3 : Indoor units between shut off valve and end of system. (Indoor Unit ④)

Line#	Description	Releasable charge per length	x	Length*	=	Total
1	Liquid Pipe Ø 25.4 mm (1.0 inch)	0.376 kg/m (0.253 lbs/ft)	x		=	
2	Liquid Pipe Ø 22.2 mm (7/8 inch)	0.286 kg/m (0.193 lbs/ft)	x		=	
3	Liquid Pipe Ø 19.05 mm (3/4 inch)	0.207 kg/m (0.139 lbs/ft)	x		=	
4	Liquid Pipe Ø 15.88 mm (5/8 inch)	0.144 kg/m (0.097 lbs/ft)	x		=	
5	Liquid Pipe Ø 12.7 mm (1/2 inch)	0.090 kg/m (0.061 lbs/ft)	x		=	
6	Liquid Pipe Ø 9.52 mm (3/8 inch)	0.047 kg/m (0.032 lbs/ft)	x		=	
7	Liquid Pipe Ø 6.35 mm (1/4 inch)	0.018 kg/m (0.012 lbs/ft)	x	5 m (16.4 ft)	=	0.09 kg (0.2 lbs)
8	Gas Pipe Ø 25.4 mm (1.0 inch)	0.030 kg/m (0.020 lbs/ft)	x		=	
9	Gas Pipe Ø 22.2 mm (7/8 inch)	0.023 kg/m (0.015 lbs/ft)	x		=	
10	Gas Pipe Ø 19.05 mm (3/4 inch)	0.016 kg/m (0.011 lbs/ft)	x		=	
11	Gas Pipe Ø 15.88 mm (5/8 inch)	0.012 kg/m (0.008 lbs/ft)	x		=	
12	Gas Pipe Ø 12.7 mm (1/2 inch)	0.007 kg/m (0.005 lbs/ft)	x		=	
13	Gas Pipe Ø 9.52 mm (3/8 inch)	0.004 kg/m (0.003 lbs/ft)	x	5 m (16.4 ft)	=	0.02 kg (0.05 lbs)
14	Gas Pipe Ø 6.35 mm (1/4 inch)	0.002 kg/m (0.001 lbs/ft)	x		=	
15	Sum of releasable charge correction factor** of Indoor Units				=	0.67 kg (1.48 lbs)
16	Releasable charge before leak detection system activate.				=	0.204 kg (0.45 lbs)
Maximum Releasable Charge (Sum of lines 1~16)					=	0.98 kg (2.18 lbs)

*Sum of all pipe (C4) length after shut off valve (B) and end of system.

**TM-A CST 1 EA(④) : 0.67 kg (1.48 lbs) / EA * 1 EA = 0.67 kg (1.48 lbs)

Use the <Table 3> to determine A_{min} with m_{rel} calculated by work sheet

<Table 3> : Table for ETRS Unit.

Maximum of m or m_{rel} is 79.56 kg (175.40 lbs)* m_{rel} is calculated value with work sheet when one or more shut off valves are used.* The releasable charge (m_{rel}) is not related to total refrigerant charge in system (m).

Minimum floor area				Minimum floor area				Minimum floor area			
m or m _{rel}		A _{min}		m or m _{rel}		A _{min}		m or m _{rel}		A _{min}	
kg	lbs	m ²	ft ²	kg	lbs	m ²	ft ²	kg	lbs	m ²	ft ²
≤ 1.836	≤ 4.04	-	-	14.20	31.31	46.41	499.50	26.80	59.08	87.58	942.72
1.84	4.06	6.01	64.72	14.40	31.75	47.06	506.54	27.00	59.52	88.24	949.76
2.00	4.41	6.54	70.35	14.60	32.19	47.71	513.57	27.20	59.97	88.89	956.79
2.20	4.85	7.19	77.39	14.80	32.63	48.37	520.61	27.40	60.41	89.54	963.83
2.40	5.29	7.84	84.42	15.00	33.07	49.02	527.64	27.60	60.85	90.20	970.86
2.60	5.73	8.50	91.46	15.20	33.51	49.67	534.68	27.80	61.29	90.85	977.90
2.80	6.17	9.15	98.49	15.40	33.95	50.33	541.71	28.00	61.73	91.50	984.93
3.00	6.61	9.80	105.53	15.60	34.39	50.98	548.75	28.20	62.17	92.16	991.97
3.20	7.05	10.46	112.56	15.80	34.83	51.63	555.78	28.40	62.61	92.81	999.00
3.40	7.50	11.11	119.60	16.00	35.27	52.29	562.82	28.60	63.05	93.46	1006.04
3.60	7.94	11.76	126.63	16.20	35.71	52.94	569.85	28.80	63.49	94.12	1013.07
3.80	8.38	12.42	133.67	16.40	36.16	53.59	576.89	29.00	63.93	94.77	1020.11
4.00	8.82	13.07	140.70	16.60	36.60	54.25	583.92	29.20	64.37	95.42	1027.14
4.20	9.26	13.73	147.74	16.80	37.04	54.90	590.96	29.40	64.82	96.08	1034.18
4.40	9.70	14.38	154.78	17.00	37.48	55.56	598.00	29.60	65.26	96.73	1041.21
4.60	10.14	15.03	161.81	17.20	37.92	56.21	605.03	29.80	65.70	97.39	1048.25
4.80	10.58	15.69	168.85	17.40	38.36	56.86	612.07	30.00	66.14	98.04	1055.29
5.00	11.02	16.34	175.88	17.60	38.80	57.52	619.10	30.20	66.58	98.69	1062.32
5.20	11.46	16.99	182.92	17.80	39.24	58.17	626.14	30.40	67.02	99.35	1069.36
5.40	11.90	17.65	189.95	18.00	39.68	58.82	633.17	30.60	67.46	100.00	1076.39
5.60	12.35	18.30	196.99	18.20	40.12	59.48	640.21	30.80	67.90	100.65	1083.43
5.80	12.79	18.95	204.02	18.40	40.57	60.13	647.24	31.00	68.34	101.31	1090.46
6.00	13.23	19.61	211.06	18.60	41.01	60.78	654.28	31.20	68.78	101.96	1097.50
6.20	13.67	20.26	218.09	18.80	41.45	61.44	661.31	31.40	69.23	102.61	1104.53
6.40	14.11	20.92	225.13	19.00	41.89	62.09	668.35	31.60	69.67	103.27	1111.57
6.60	14.55	21.57	232.16	19.20	42.33	62.75	675.38	31.80	70.11	103.92	1118.60
6.80	14.99	22.22	239.20	19.40	42.77	63.40	682.42	32.00	70.55	104.58	1125.64
7.00	15.43	22.88	246.23	19.60	43.21	64.05	689.45	32.20	70.99	105.23	1132.67
7.20	15.87	23.53	253.27	19.80	43.65	64.71	696.49	32.40	71.43	105.88	1139.71
7.40	16.31	24.18	260.30	20.00	44.09	65.36	703.52	32.60	71.87	106.54	1146.74
7.60	16.76	24.84	267.34	20.20	44.53	66.01	710.56	32.80	72.31	107.19	1153.78
7.80	17.20	25.49	274.37	20.40	44.97	66.67	717.59	33.00	72.75	107.84	1160.81
8.00	17.64	26.14	281.41	20.60	45.42	67.32	724.63	33.20	73.19	108.50	1167.85
8.20	18.08	26.80	288.44	20.80	45.86	67.97	731.66	33.40	73.63	109.15	1174.88
8.40	18.52	27.45	295.48	21.00	46.30	68.63	738.70	33.60	74.08	109.80	1181.92
8.60	18.96	28.10	302.52	21.20	46.74	69.28	745.73	33.80	74.52	110.46	1188.95
8.80	19.40	28.76	309.55	21.40	47.18	69.93	752.77	34.00	74.96	111.11	1195.99
9.00	19.84	29.41	316.59	21.60	47.62	70.59	759.81	34.20	75.40	111.76	1203.03
9.20	20.28	30.07	323.62	21.80	48.06	71.24	766.84	34.40	75.84	112.42	1210.06
9.40	20.72	30.72	330.66	22.00	48.50	71.90	773.88	34.60	76.28	113.07	1217.10
9.60	21.16	31.37	337.69	22.20	48.94	72.55	780.91	34.80	76.72	113.73	1224.13
9.80	21.61	32.03	344.73	22.40	49.38	73.20	787.95	35.00	77.16	114.38	1231.17
10.00	22.05	32.68	351.76	22.60	49.82	73.86	794.98	35.20	77.60	115.03	1238.20
10.20	22.49	33.33	358.80	22.80	50.27	74.51	802.02	35.40	78.04	115.69	1245.24
10.40	22.93	33.99	365.83	23.00	50.71	75.16	809.05	35.60	78.48	116.34	1252.27
10.60	23.37	34.64	372.87	23.20	51.15	75.82	816.09	35.80	78.93	116.99	1259.31
10.80	23.81	35.29	379.90	23.40	51.59	76.47	823.12	36.00	79.37	117.65	1266.34
11.00	24.25	35.95	386.94	23.60	52.03	77.12	830.16	36.20	79.81	118.30	1273.38
11.20	24.69	36.60	393.97	23.80	52.47	77.78	837.19	36.40	80.25	118.95	1280.41
11.40	25.13	37.25	401.01	24.00	52.91	78.43	844.23	36.60	80.69	119.61	1287.45
11.60	25.57	37.91	408.04	24.20	53.35	79.08	851.26	36.80	81.13	120.26	1294.48
11.80	26.01	38.56	415.08	24.40	53.79	79.74	858.30	37.00	81.57	120.92	1301.52
12.00	26.46	39.22	422.11	24.60	54.23	80.39	865.33	37.20	82.01	121.57	1308.55
12.20	26.90	39.87	429.15	24.80	54.67	81.05	872.37	37.40	82.45	122.22	1315.59
12.40	27.34	40.52	436.18	25.00	55.12	81.70	879.40	37.60	82.89	122.88	1322.62
12.60	27.78	41.18	443.22	25.20	55.56	82.35	886.44	37.80	83.33	123.53	1329.66
12.80	28.22	41.83	450.26	25.40	56.00	83.01	893.47	38.00	83.78	124.18	1336.69
13.00	28.66	42.48	457.29	25.60	56.44	83.66	900.51	38.20	84.22	124.84	1343.73
13.20	29.10	43.14	464.33	25.80	56.88	84.31	907.55	38.40	84.66	125.49	1350.77
13.40	29.54	43.79	471.36	26.00	57.32	84.97	914.58	38.60	85.10	126.14	1357.80
13.60	29.98	44.44	478.40	26.20	57.76	85.62	921.62	38.80	85.54	126.80	1364.84
13.80	30.42	45.10	485.43	26.40	58.20	86.27	928.65	39.00	85.98	127.45	1371.87
14.00	30.86	45.75	492.47	26.60	58.64	86.93	935.69	39.20	86.42	128.10	1378.91

Cassette Indoor Units Installation General Information

Minimum floor area				Minimum floor area				Minimum floor area			
m or m _{rel}		A _{min}		m or m _{rel}		A _{min}		m or m _{rel}		A _{min}	
kg	lbs	m ²	ft ²	kg	lbs	m ²	ft ²	kg	lbs	m ²	ft ²
39.40	86.86	128.76	1385.94	53.20	117.29	173.86	1871.37	67.00	147.71	218.95	2356.80
39.60	87.30	129.41	1392.98	53.40	117.73	174.51	1878.41	67.20	148.15	219.61	2363.84
39.80	87.74	130.07	1400.01	53.60	118.17	175.16	1885.44	67.40	148.59	220.26	2370.87
40.00	88.18	130.72	1407.05	53.80	118.61	175.82	1892.48	67.60	149.03	220.92	2377.91
40.20	88.63	131.37	1414.08	54.00	119.05	176.47	1899.51	67.80	149.47	221.57	2384.94
40.40	89.07	132.03	1421.12	54.20	119.49	177.12	1906.55	68.00	149.91	222.22	2391.98
40.60	89.51	132.68	1428.15	54.40	119.93	177.78	1913.58	68.20	150.36	222.88	2399.02
40.80	89.95	133.33	1435.19	54.60	120.37	178.43	1920.62	68.40	150.80	223.53	2406.05
41.00	90.39	133.99	1442.22	54.80	120.81	179.08	1927.65	68.60	151.24	224.18	2413.09
41.20	90.83	134.64	1449.26	55.00	121.25	179.74	1934.69	68.80	151.68	224.84	2420.12
41.40	91.27	135.29	1456.29	55.20	121.70	180.39	1941.73	69.00	152.12	225.49	2427.16
41.60	91.71	135.95	1463.33	55.40	122.14	181.05	1948.76	69.20	152.56	226.14	2434.19
41.80	92.15	136.60	1470.36	55.60	122.58	181.70	1955.80	69.40	153.00	226.80	2441.23
42.00	92.59	137.25	1477.40	55.80	123.02	182.35	1962.83	69.60	153.44	227.45	2448.26
42.20	93.04	137.91	1484.43	56.00	123.46	183.01	1969.87	69.80	153.88	228.10	2455.30
42.40	93.48	138.56	1491.47	56.20	123.90	183.66	1976.90	70.00	154.32	228.76	2462.33
42.60	93.92	139.22	1498.51	56.40	124.34	184.31	1983.94	70.20	154.76	229.41	2469.37
42.80	94.36	139.87	1505.54	56.60	124.78	184.97	1990.97	70.40	155.21	230.07	2476.40
43.00	94.80	140.52	1512.58	56.80	125.22	185.62	1998.01	70.60	155.65	230.72	2483.44
43.20	95.24	141.18	1519.61	57.00	125.66	186.27	2005.04	70.80	156.09	231.37	2490.47
43.40	95.68	141.83	1526.65	57.20	126.10	186.93	2012.08	71.00	156.53	232.03	2497.51
43.60	96.12	142.48	1533.68	57.40	126.55	187.58	2019.11	71.20	156.97	232.68	2504.54
43.80	96.56	143.14	1540.72	57.60	126.99	188.24	2026.15	71.40	157.41	233.33	2511.58
44.00	97.00	143.79	1547.75	57.80	127.43	188.89	2033.18	71.60	157.85	233.99	2518.61
44.20	97.44	144.44	1554.79	58.00	127.87	189.54	2040.22	71.80	158.29	234.64	2525.65
44.40	97.89	145.10	1561.82	58.20	128.31	190.20	2047.25	72.00	158.73	235.29	2532.68
44.60	98.33	145.75	1568.86	58.40	128.75	190.85	2054.29	72.20	159.17	235.95	2539.72
44.80	98.77	146.41	1575.89	58.60	129.19	191.50	2061.32	72.40	159.61	236.60	2546.76
45.00	99.21	147.06	1582.93	58.80	129.63	192.16	2068.36	72.60	160.06	237.25	2553.79
45.20	99.65	147.71	1589.96	59.00	130.07	192.81	2075.39	72.80	160.50	237.91	2560.83
45.40	100.09	148.37	1597.00	59.20	130.51	193.46	2082.43	73.00	160.94	238.56	2567.86
45.60	100.53	149.02	1604.03	59.40	130.95	194.12	2089.46	73.20	161.38	239.22	2574.90
45.80	100.97	149.67	1611.07	59.60	131.40	194.77	2096.50	73.40	161.82	239.87	2581.93
46.00	101.41	150.33	1618.10	59.80	131.84	195.42	2103.54	73.60	162.26	240.52	2588.97
46.20	101.85	150.98	1625.14	60.00	132.28	196.08	2110.57	73.80	162.70	241.18	2596.00
46.40	102.29	151.63	1632.17	60.20	132.72	196.73	2117.61	74.00	163.14	241.83	2603.04
46.60	102.74	152.29	1639.21	60.40	133.16	197.39	2124.64	74.20	163.58	242.48	2610.07
46.80	103.18	152.94	1646.25	60.60	133.60	198.04	2131.68	74.40	164.02	243.14	2617.11
47.00	103.62	153.59	1653.28	60.80	134.04	198.69	2138.71	74.60	164.46	243.79	2624.14
47.20	104.06	154.25	1660.32	61.00	134.48	199.35	2145.75	74.80	164.91	244.44	2631.18
47.40	104.50	154.90	1667.35	61.20	134.92	200.00	2152.78	75.00	165.35	245.10	2638.21
47.60	104.94	155.56	1674.39	61.40	135.36	200.65	2159.82	75.20	165.79	245.75	2645.25
47.80	105.38	156.21	1681.42	61.60	135.80	201.31	2166.85	75.40	166.23	246.41	2652.28
48.00	105.82	156.86	1688.46	61.80	136.25	201.96	2173.89	75.60	166.67	247.06	2659.32
48.20	106.26	157.52	1695.49	62.00	136.69	202.61	2180.92	75.80	167.11	247.71	2666.35
48.40	106.70	158.17	1702.53	62.20	137.13	203.27	2187.96	76.00	167.55	248.37	2673.39
48.60	107.14	158.82	1709.56	62.40	137.57	203.92	2194.99	76.20	167.99	249.02	2680.42
48.80	107.59	159.48	1716.60	62.60	138.01	204.58	2202.03	76.40	168.43	249.67	2687.46
49.00	108.03	160.13	1723.63	62.80	138.45	205.23	2209.06	76.60	168.87	250.33	2694.50
49.20	108.47	160.78	1730.67	63.00	138.89	205.88	2216.10	76.80	169.32	250.98	2701.53
49.40	108.91	161.44	1737.70	63.20	139.33	206.54	2223.13	77.00	169.76	251.63	2708.57
49.60	109.35	162.09	1744.74	63.40	139.77	207.19	2230.17	77.20	170.20	252.29	2715.60
49.80	109.79	162.75	1751.77	63.60	140.21	207.84	2237.20	77.40	170.64	252.94	2722.64
50.00	110.23	163.40	1758.81	63.80	140.65	208.50	2244.24	77.60	171.08	253.59	2729.67
50.20	110.67	164.05	1765.84	64.00	141.10	209.15	2251.28	77.80	171.52	254.25	2736.71
50.40	111.11	164.71	1772.88	64.20	141.54	209.80	2258.31	78.00	171.96	254.90	2743.74
50.60	111.55	165.36	1779.91	64.40	141.98	210.46	2265.35	78.20	172.40	255.56	2750.78
50.80	111.99	166.01	1786.95	64.60	142.42	211.11	2272.38	78.40	172.84	256.21	2757.81
51.00	112.44	166.67	1793.99	64.80	142.86	211.76	2279.42	78.60	173.28	256.86	2764.85
51.20	112.88	167.32	1801.02	65.00	143.30	212.42	2286.45	78.80	173.72	257.52	2771.88
51.40	113.32	167.97	1808.06	65.20	143.74	213.07	2293.49	79.00	174.17	258.17	2778.92
51.60	113.76	168.63	1815.09	65.40	144.18	213.73	2300.52	79.20	174.61	258.82	2785.95
51.80	114.20	169.28	1822.13	65.60	144.62	214.38	2307.56	79.40	175.05	259.48	2792.99
52.00	114.64	169.93	1829.16	65.80	145.06	215.03	2314.59	79.60	175.49	260.13	2800.02
52.20	115.08	170.59	1836.20	66.00	145.51	215.69	2321.63	79.80	175.93	260.78	2807.06
52.40	115.52	171.24	1843.23	66.20	145.95	216.34	2328.66	80.00	176.37	261.43	2814.09
52.60	115.96	171.90	1850.27	66.40	146.39	216.99	2335.70	80.20	176.81	262.08	2821.13
52.80	116.40	172.55	1857.30	66.60	146.83	217.65	2342.73	80.40	177.25	262.73	2828.16
53.00	116.84	173.20	1864.34	66.80	147.27	218.30	2349.77	80.60	177.69	263.38	2835.20

Altitude adjustment

The minimum floor area (A_{\min} or A_{alarm}) shall be corrected by multiplying by the altitude adjustment factor (AF) in the below table based on for building site ground level altitude (Halt) in meters (feet).

Unit : m (ft)

Halt	0	200 (656.2)	400 (1312.3)	600 (1968.5)	800 (2624.7)	1 000 (3 280.8)
AF	1	1	1	1	1.02	1.05
Halt	1 200 (3 937.0)	1 400 (4 593.2)	1 600 (5 249.3)	1 800 (5 905.5)	2 000 (6 561.7)	
AF	1.07	1.1	1.12	1.15	1.18	

Installation

Read completely, then follow step by step.

Selection of the best location

- There should not be any heat source or steam near the unit.
- There should not be any obstacles to the air circulation.
- A place where air circulation in the room will be good.
- A place where drainage can be easily obtained.
- A place where noise prevention is taken into consideration.
- Do not install the unit near the door way.
- Ensure the spaces indicated by arrows from the wall, ceiling, or other obstacles.
- The indoor unit must have the maintenance space.
- Do not install indoor units in laundry rooms.

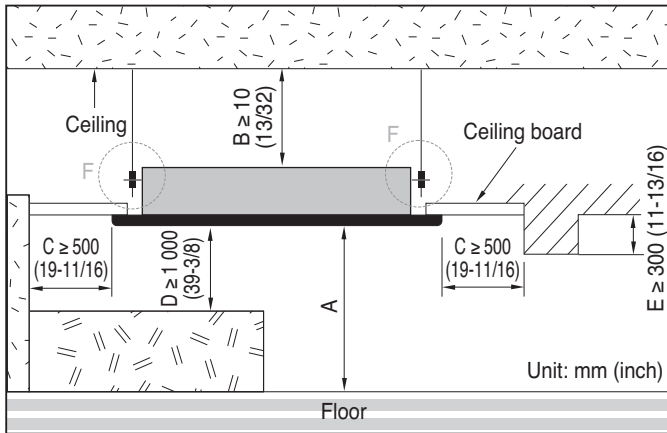

Model		A
1 Way		1 800 (70-55/64) < A ≤ 3 300 (129-59/64)
2 Way		1 800 (70-55/64) < A ≤ 3 300 (129-59/64)
4 Way	Below 34 kBtu/h	2 000 (78-47/64) < A ≤ 3 600 (141-23/32)
	Over 34 kBtu/h	2 500 (98-27/64) < A ≤ 4 200 (165-11/32)

⚠ CAUTION

In case that the unit is installed near the sea, the installation parts may be corroded by salt. The installation parts (and the unit) should be taken appropriate anti-corrosion measures.

⚠ CAUTION

Don't install additional ventilation products on the cabinet of cassette type air conditioner.

Ceiling dimension and hanging bolt location

• The dimensions of the paper model for installation are the same as those of the ceiling opening dimensions.

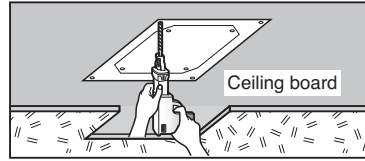
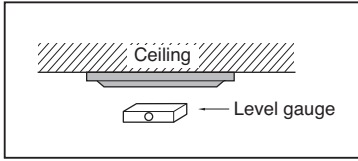

1 WAY

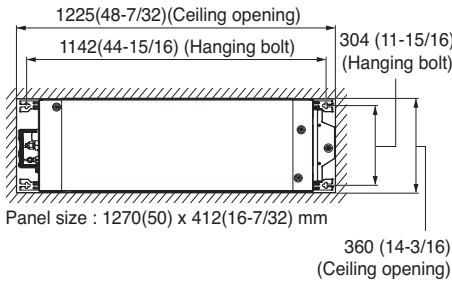

2 WAY

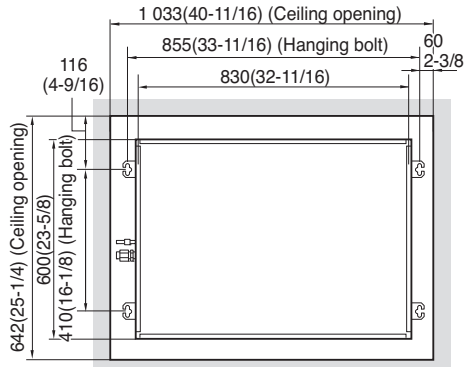

Unit: mm (inch)

4 WAY

TQ/TR Chassis

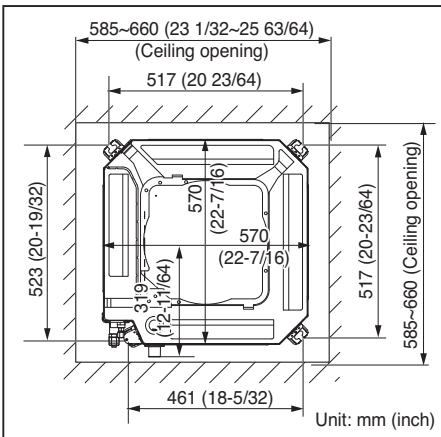

TM-A/TP-B Chassis

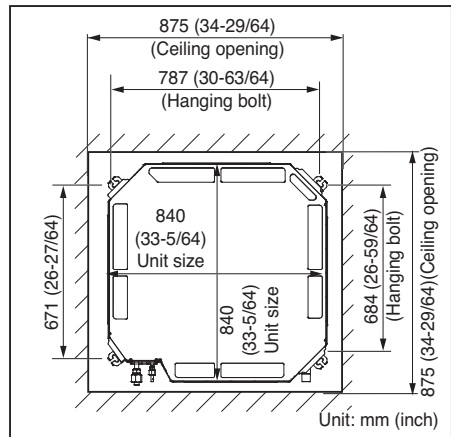

※ Please use an annexed sheet or the corrugated cardboard on the bottom of packing as installation sheet.



Annexed sheet



Packing corrugated cardboard on the bottom

※ When using the bottom sheet, please use it after separating the installation sheet from packing of the product floor by using a knife etc as a picture below.

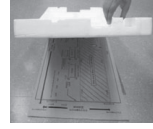
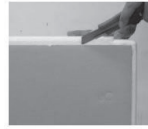

- Select and mark the position for fixing bolts and piping hole.
- Decide the position for fixing bolts slightly tilted to the drain direction after considering the direction of drain hose.
- Drill the hole for anchor bolt on the wall.

NOTE

Avoid the following installation location.

1. Such places as restaurants and kitchen where considerable amount of oil steam and flour is generated.
These may cause heat exchange efficiency reduction, or water drops, drain pump mal-function. In these cases, take the following actions;
 - Make sure that ventilation fan is enough to cover all noxious gases from this place.
 - Ensure enough distance from the cooking room to install the air conditioner in such a place where it may not suck oily steam.
2. Avoid installing air conditioner in such places where cooking oil or iron powder is generated.
3. Avoid places where inflammable gas is generated.
4. Avoid place where noxious gas is generated.
5. Avoid places near high frequency generators.

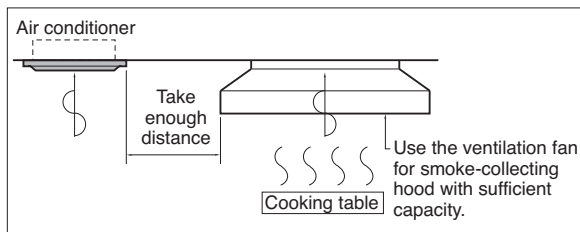

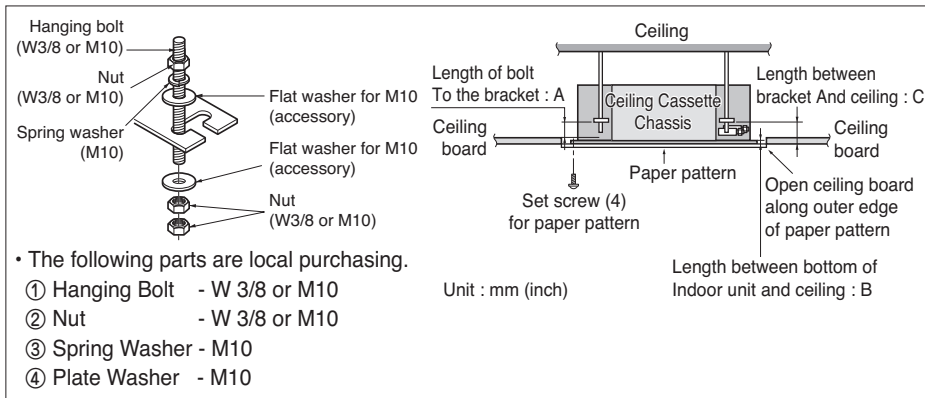

Model		A	B	C
1 Way	TC	30 (1-3/16)	0 (0)	61 (2-13/32)
2 Way	TS	40 (1-9/16)	18~24 (23/32~61/64)	90 (3-17/32)
4 Way	TQ/TR	40 (1-9/16)	27~33 (1-1/16 ~ 1-5/16)	180 (7-3/32)
	TM-A/TP-B	40 (1-9/16)	12~18 (15/32 ~ 23/32)	105 (4-9/64)

⚠ CAUTION

- Tighten the nut and bolt to prevent the unit from falling.
- When mechanical connectors are reused indoors, sealing parts shall be renewed.
- When flared joints are reused indoors, the flare part shall be re-fabricated.
- This air-conditioner uses a drain pump.
- Install the unit horizontally using a level gauge.
- During the installation, care should be taken not to damage electric wires.

Wiring Connection

- Connect the wires to the terminals on the control box individually according to the outdoor unit connection.
- Ensure that the color of the wires of outdoor unit and the terminal No. are the same as those of indoor unit respectively.

<TC>

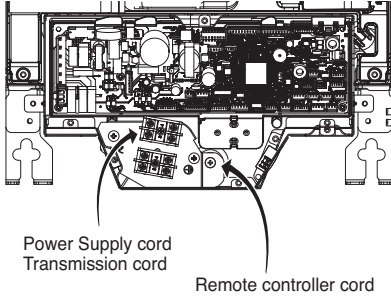

<TS>

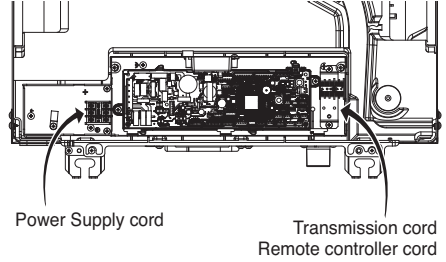

<TQ/TR>

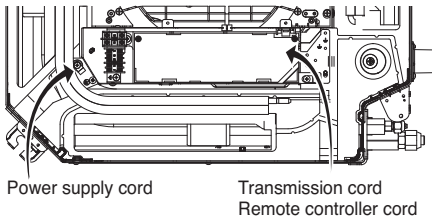

< TM-A/TP-B >

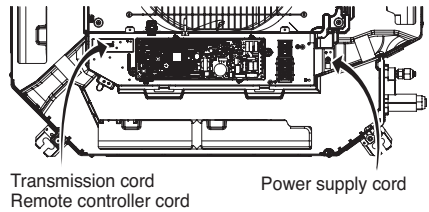

• **TC Chassis**

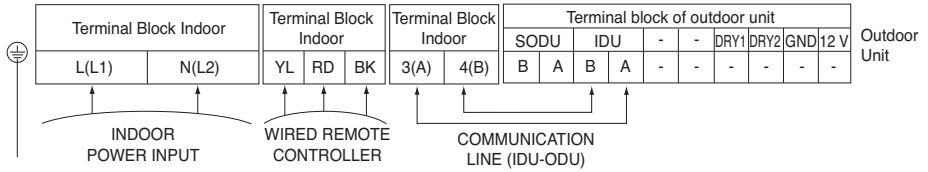

• **TS Chassis**

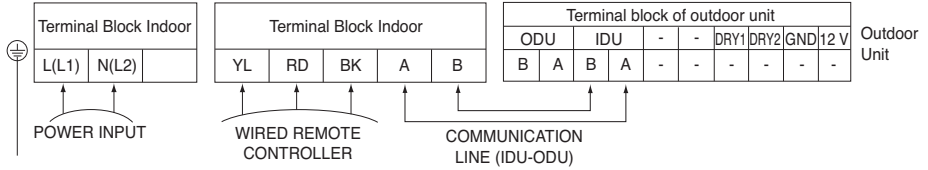

• **TQ/TR Chassis**

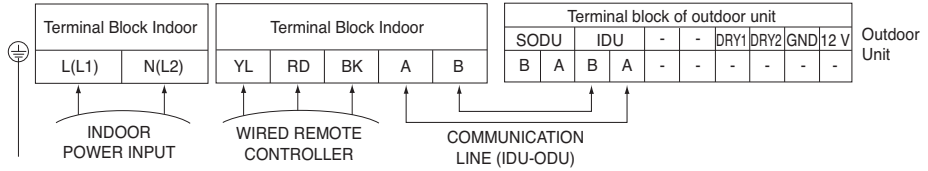

• **TM-A/TP-B Chassis**

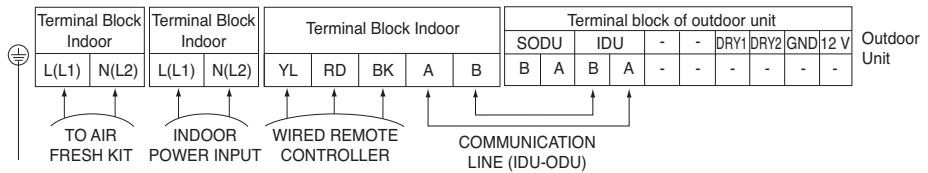

Connection method of the connecting cable (Example)

- All communication and power wiring must be connected to the terminals using connectors certified or recognized according to UL and CSA standard.

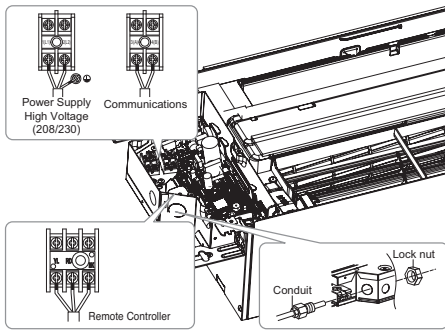

TC Chassis

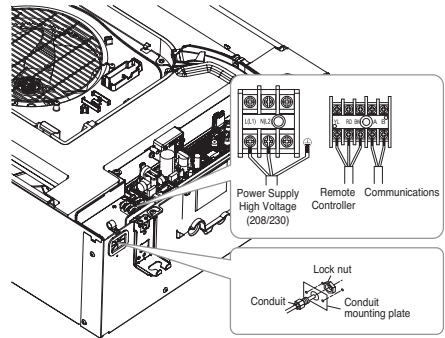

TS Chassis

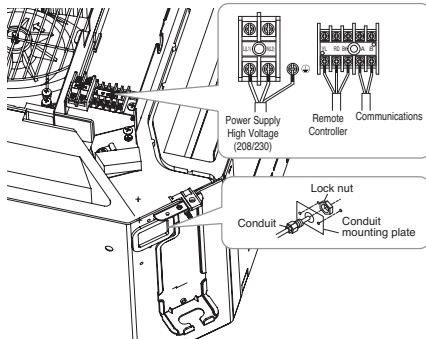

TQ/TR Chassis

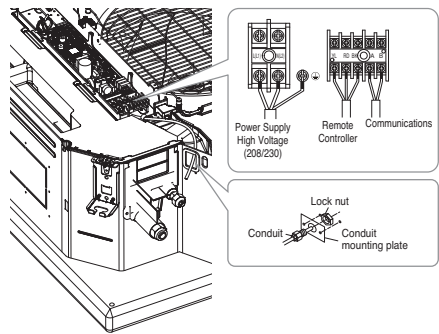

TM-A/TP-B Chassis

⚠ WARNING

Loose wiring may cause the terminal to overheat or result in unit malfunction. A fire hazard may also exist. Therefore, be sure all wiring is tightly connected. Make sure that the screws of the terminal are free from looseness.

⚠ CAUTION

The Power cord connected to the unit should be selected according to the following specifications.

⚠ CAUTION

After the confirmation of the above conditions, prepare the wiring as follows:

- 1) Never fail to have an individual power specialized for the air conditioner. As for the method of wiring, be guided by the circuit diagram posted on the inside of control box cover.
- 2) Provide a circuit breaker switch between power source and the unit.
- 3) The screws which fasten the wiring in the casing of electrical fittings are liable to come loose from vibrations to which the unit is subjected during the course of transportation. Check them and make sure that they are all tightly fastened. (If they are loose, it could give rise to burn-out of the wires.)
- 4) Specification of power source
- 5) Confirm that electrical capacity is sufficient.
- 6) Be sure that the starting voltage is maintained at more than 90 percent of the rated voltage marked on the name plate.
- 7) Confirm that the cable thickness is as specified in the power sources specification. (Particularly note the relation between cable length and thickness.)
- 8) Never fail to equip a leakage breaker where it is wet or moist.
- 9) The following troubles would be caused by voltage drop-down.
 - Vibration of a magnetic switch, damage on the contact point, fuse breaking, disturbance by the normal function of an overload protection device.
 - Proper starting power is not given to the compressor.

HAND OVER

Teach the customer the operation and maintenance procedures, using the operation manual. (air filter cleaning, temperature control, etc.)

⚠ CAUTION

- Please refer to the instructions below for proper installation.
 - Power wiring/power wiring gauge to the outdoor unit(s) must be solid or stranded and must comply with all National Electrical Code (NEC), UL, and local electrical codes.
 - Communication wiring cable from the outdoor unit must be minimum 18AWG, 2-conductor, twisted, stranded, and shielded (If shielded, must be grounded to the outdoor unit chassis only)

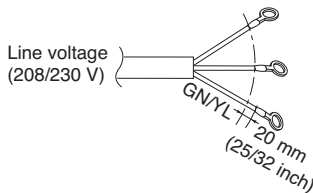

Power supply cable

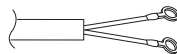

Communication cable

- If the supply cord is damaged, it must be replaced by a special cord or assembly available from the manufacturer of its service agent.
- Pipes and wires should be purchased separately for installation of the product.

◆ Precautions when laying power and ground wiring

Use round pressure terminals for connections to the power terminal block.
When laying ground wiring, you must use round pressure terminals.

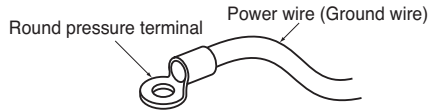

When none are available, follow the instructions below.

- Do not connect wiring of different thicknesses to the power terminal block. (Slack in the power wiring may cause abnormal heat.)
- When connecting wiring which is the same thickness, do as shown in the figure below.

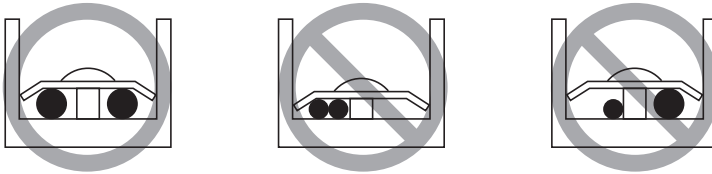



- For wiring, use the designated power wire and connect firmly, then secure to prevent outside pressure being exerted on the terminal block.
- Use an appropriate screwdriver for tightening the terminal screws. A screwdriver with a small head will strip the head and make proper tightening impossible.
- Over-tightening the terminal screws may break them.

Plumbing materials and storage methods

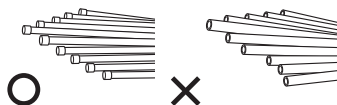
Pipe must be able to obtain the specified thickness and should be used with low impurities. Also when handling storage, pipe must be careful to prevent a fracture, deformity and wound. Should not be mixed with contaminations such as dust, moisture.



Refrigerant piping on three principles

	Drying	Cleanliness	Airtight
	Should be no moisture inside	No dust inside.	There is no refrigerant leakage
Items			
Cause failure	<ul style="list-style-type: none"> - Significant hydrolysis of refrigerant oil - Degradation of refrigerant oil - Poor insulation of the compressor - Do not cold and warm - Clogging of EEV, Capillary 	<ul style="list-style-type: none"> - Degradation of refrigerant oil - Poor insulation of the compressor - Do not cold and warm - Clogging of EEV, Capillary 	<ul style="list-style-type: none"> - Gas shortages - Degradation of refrigerant oil - Poor insulation of the compressor - Do not cold and warm
Countermeasure	<ul style="list-style-type: none"> - No moisture in the pipe - Until the connection is completed, the plumbing pipe entrance should be strictly controlled. - Stop plumbing at rainy day. - Pipe entrance should be taken side or bottom. - When removal burr after cutting pipe, pipe entrance should be taken down. - Pipe entrance should be fitted cap when pass through the walls. 	<ul style="list-style-type: none"> - No dust in the pipe. - Until the connection is completed, the plumbing pipe entrance should be strictly controlled. - Pipe entrance should be taken side or bottom. - When removal burr after cutting pipe, pipe entrance should be taken down. - Pipe entrance should be fitted cap when pass through the walls. 	<ul style="list-style-type: none"> - Airtightness test should be. - Brazing operations to comply with standards. - Flare to comply with standards. - Flange connections to comply with standards.

Nitrogen substitution method

Welding, as when heating without nitrogen substitution a large amount of the oxide film is formed on the internal piping.

The oxide film is caused by clogging EEV, Capillary, oil hole of accumulator and suction hole of oil pump in compressor.

It prevents normal operation of the compressor.

In order to avoid this problem, Welding should be done after replacing air by nitrogen gas.

When welding plumbing pipe, the work is required.

◆ How to work

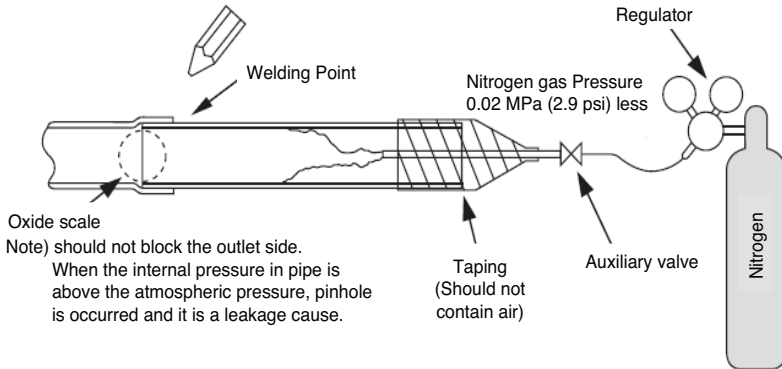

⚠ CAUTION

1. Always use the nitrogen.

(not use oxygen, carbon dioxide, and a Chevron gas)

Please use the following nitrogen pressure 0.02 MPa (2.9 psi)

Oxygen : Promotes oxidative degradation of refrigerant oil.

Because it is flammable, it is strictly prohibited to use

Carbon dioxide : Degrade the drying characteristics of gas

Chevron Gas : Toxic gas occurs when exposed to direct flame.

2. Always use a pressure reducing valve.

3. Please do not use commercially available antioxidant.

The residual material seems to be the oxide scale is observed.

In fact, due to the organic acids generated by oxidation of the alcohol contained in the anti-oxidants, ants nest corrosion occurs.

(causes of organic acid → alcohol + copper + water + temperature)

Flaring Work

Main cause for gas leakage is due to defect of flaring work. Carry out correct flaring work in the following procedure.

Cut the pipes and the cable

1. Use the piping kit accessory or the pipes purchased locally.
2. Measure the distance between the indoor and the outdoor unit.
3. Cut the pipes a little longer than measured distance.
4. Cut the cable 1.5 m longer than the pipe length.

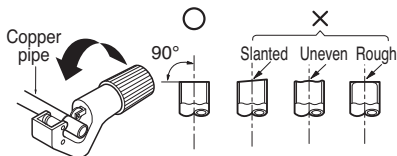

Burrs removal

1. Completely remove all burrs from the cut cross section of pipe/tube.
2. While removing burrs put the end of the copper tube/pipe in a downward direction while removing burrs location is also changed in order to avoid dropping burrs into the tubing.

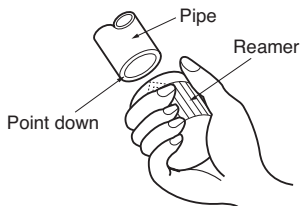

Putting nut on

- Remove flare nuts attached to indoor and outdoor unit, then put them on pipe/tube having completed burr removal. (not possible to put them on after finishing flare work)

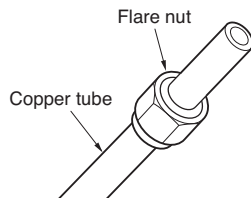

Flaring work

1. Firmly hold copper pipe in a bar with the dimension shown in below table below.
2. Carry out flaring work with the flaring tool.

Pipe diameter Inch (mm)	A inch (mm)	
	Wing nut type	Clutch type
Ø 1/4 (Ø 6.35)	0.04~0.05(1.1~1.3)	0~0.02 (0~0.5)
Ø 3/8 (Ø 9.52)	0.06~0.07(1.5~1.7)	
Ø 1/2 (Ø 12.7)	0.06~0.07(1.6~1.8)	
Ø 5/8 (Ø 15.88)	0.06~0.07(1.6~1.8)	
Ø 3/4 (Ø 19.05)	0.07~0.08(1.9~2.1)	

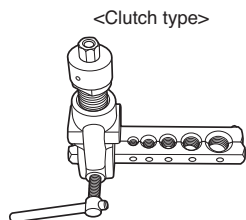
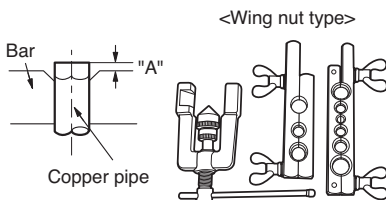

Flare Fittings

- All unit flare fittings are 45° and are rated for high-pressure R32 refrigerant.
- Properly form all flare fittings using best practices.
- Place a drop of PVE oil on the outside of flare fitting before tightening.

Checking the safe handling

Mark refrigerant pipes with red Pantone® Matching System (PMS) #185 or RAL 3020 after flare fittings or brazing. This marking must extend a minimum of 1 inch (25mm) in both directions and shall be replaced if removed.

Return all labels, especially red marking, to their original condition to ensure the next consumer or servicer is aware of the presence of a flammable refrigerant.

Ensure that the red marking for flammable refrigerant identification in the process tube area is visible following servicing.

Typical Refrigerant Line Flare Fitting Insulation Detail

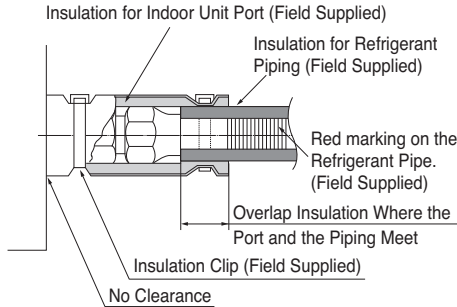

Insulation of pipes (Details)

Plastic band (for pipe) * Insulation for connecting pipes (sold separately)
(Use one with a heat resistance of 120 °C or higher.)

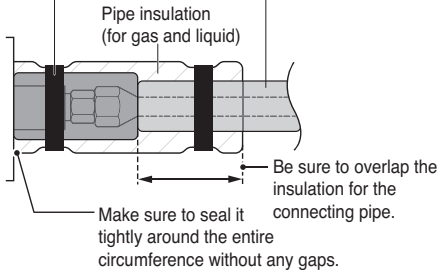

* When using pipe insulation, make sure the cutting line is facing upward.
(If it is facing downward, it can cause water leaks.)



(X)

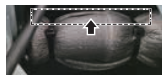

(O)

Installation of Decorative Panel (Accessory) 1-Way

Installation details are in the decorative panel installation manual.
Please refer to before working.

Front Panel Configuration

Front Panel (TC Chassis)

Size(W*H*D): 1270*30*412 mm (50*1-3/16*16-7/32 in.)

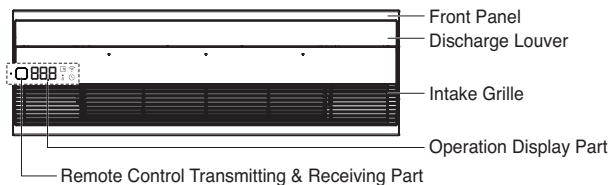

* The operation display part is displayed when the product is in operation.

CAUTION

- The indoor unit installation height should be adjusted so that the ceiling and the floor of the indoor unit are the same height.
- If the floor of the indoor unit is installed inside the ceiling, the discharge louver may not work.

In addition, cold air may leak, causing condensation or water leakage.

- If the floor of the indoor unit is installed outside the ceiling, a gap may occur between the front panel and the ceiling.
- Install the front panel with the indoor unit's c/box cover (A) part assembled first.
- Check the opening direction of the discharge louver and open it.

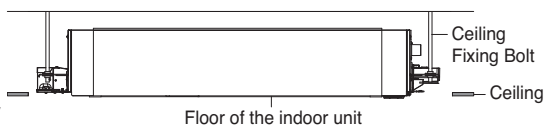

* Discharge Louver Opening Direction

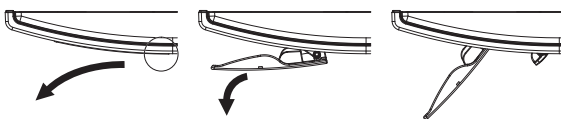

- When separating the intake grille, do not hold the remote control transmitting & receiving part side.
- After installing the front panel, be sure to remove the protective vinyl.

1. Separate an intake grille and a pre-filter.

- Open the intake grille by pressing arrows (3 ea) at the end of the intake grille.
- Open a decor cover (A) and disconnect a wire (1 ea) connected to the intake grille from a hook on a front panel, then remove the intake grille as shown below.
- Remove the pre-filter as shown below.

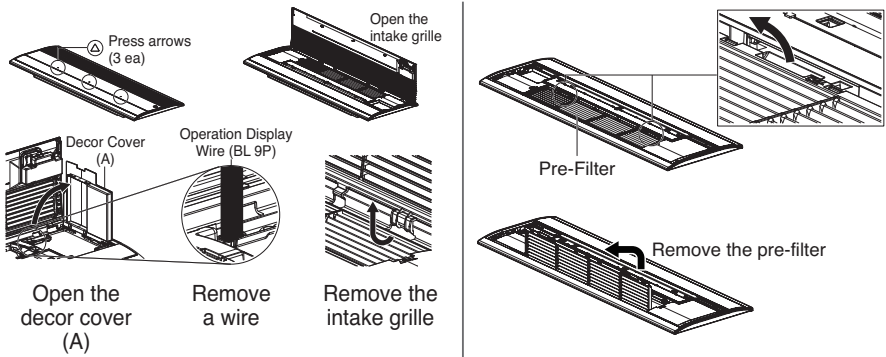

* When separating the intake grille, do not hold the remote control transmitting & receiving part side.

2. Hang the hooks (2 ea) on the front panel to the indoor unit body and secure the front panel.

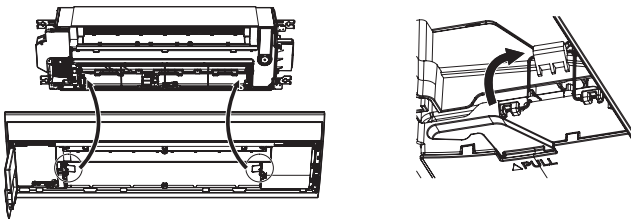

* Make sure the wires (2 ea) on the front panel go inside the indoor unit body.

3. Open the discharge louver and decor cover (B) as shown below.

- Push the back of the discharge louver in the direction of the arrow to open it completely. (Do not pull the front of the discharge louver.)

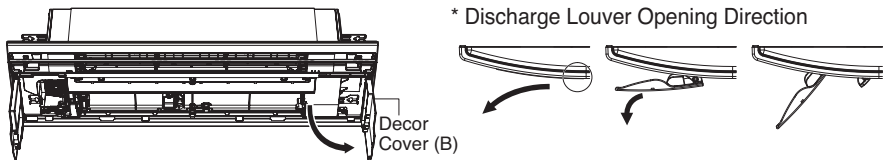

* Check the opening direction of the discharge louver.

- Remove the discharge louver by pushing the links (A, B) of it to the side.

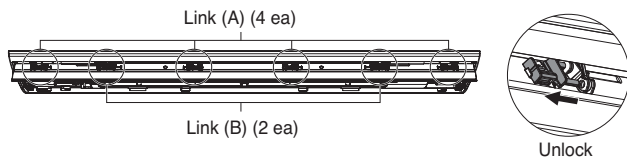

4. Fasten the front panel and the indoor unit with the enclosed installation screws (7 ea).

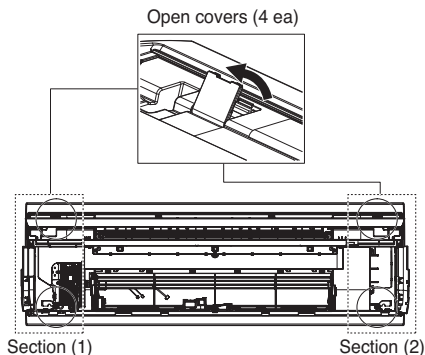

M5, 20 mm (25/32 in.), Black - 4 ea

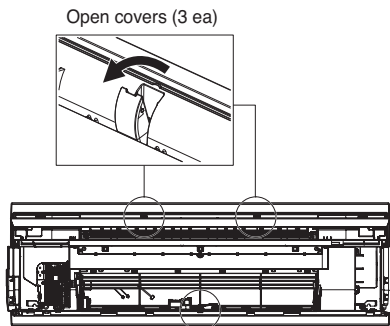

M4, 15 mm (19/32 in.), Silver - 3 ea

* Fastening in the order of (1)-(2) sections will make installation easier.

- Assemble the discharge louver by pushing the links (A, B) of it to the side.

* Check

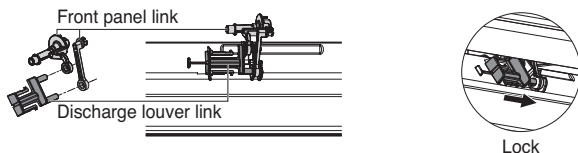

* It is convenient to assemble link (A) first.

* After assembly, all the links on the front panel must be connected to the links on the discharge louver.

5. Reassemble the intake grille, and hang the wire (1 ea) connected to the intake grille on the hook on the front panel as shown below.

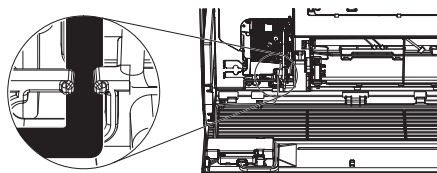

6. Connect the wires (2 ea) on the front panel to the housing inside the main PCB.
- Refer to the wiring diagram attached to the inside of the c/box cover (B).

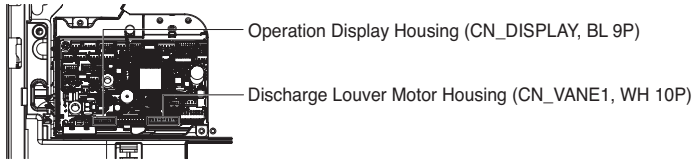

7. Assemble and close the c/box cover (B), decor covers (A, B) and the discharge louver.

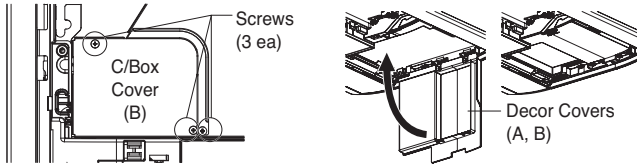

* Discharge Louver Closing Direction

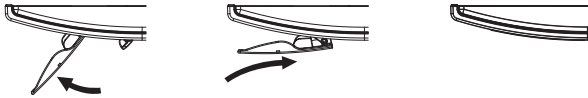

※ Check the closing direction of the discharge louver.

8. Assemble the pre-filter and close the intake grille.
- Press the arrows (3 ea) at the end of the intake grille to fully attach it.

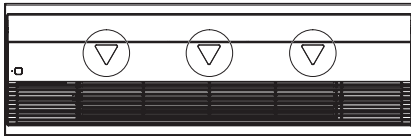

Installation of Decoration Panel (2 WAY)

The decoration panel has its installation direction.

Before installing the decoration panel, always remove the paper template.

1. Temporarily fix two decoration panel fixing screws (hexagon M5 screw) on the unit body. (Tighten by amount 10 mm (3/8 inch) in length.)
The fixing screws (hexagon M5 screw) are included the indoor unit box.
2. Remove the air inlet grille from the decoration panel. (Remove the hook for the air inlet grille cord.)
3. Hook the decoration panel key hole () on the screws fixed in step above, and slide the panel so that the screws reach the key hole edge.
4. Retighten completely two temporarily fixed screws and other two screws. (Total 4 screws)
5. Connect the louver motor connector and display connector.
6. After tightening these screws, install the air inlet grille (including the air filter).

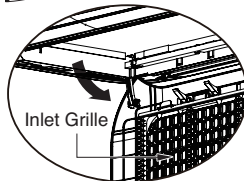
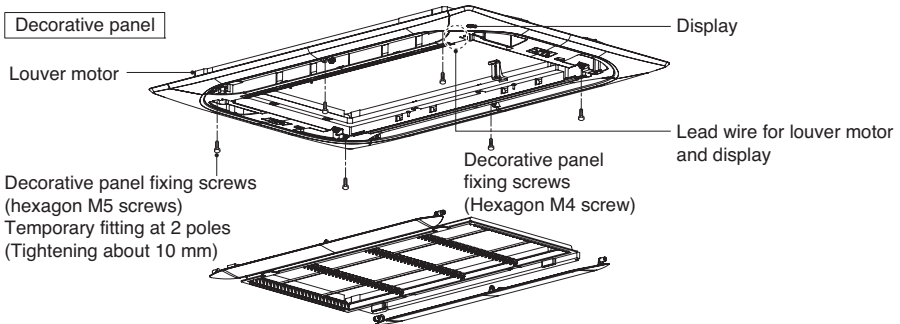
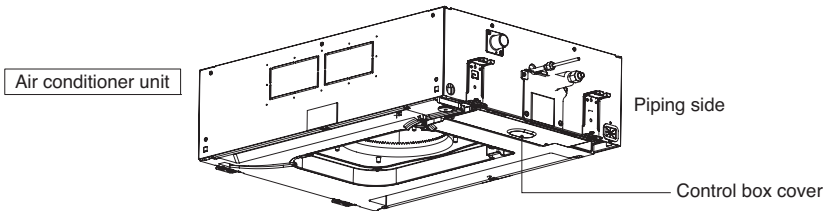

⚠ CAUTION

Install certainly the decoration panel.
Cool air leakage causes sweating.
☞ Water drops fall.

Good example

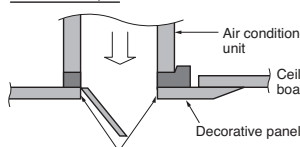

Bad example

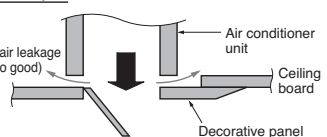

Fit the insulator (this part) and be careful for cool air leakage

Installation of Decoration Panel (4 Way)

The decoration panel has its installation direction.

Before installing the decoration panel, always remove the paper template.

1. Temporarily fix two decoration panel fixing screws (hexagon M5 screw) on the unit body. (Tighten by amount 10mm(3/8 inch) in length. The fixing screws (hexagon M5 screw) are included in the indoor unit box.
2. Remove the air inlet grille from the decoration panel. (Remove the hook for the air inlet grille cord.)
3. Hook the decoration panel key hole () on the screws fixed in step above, and slide the panel so that the screws reach the key hole edge.
4. Retighten completely two temporarily fixed screws and other two screws. (Total 4 screws)
5. Connect the louver motor connector and display connector.
6. After tightening these screws, install the air inlet grille (including the air filter).

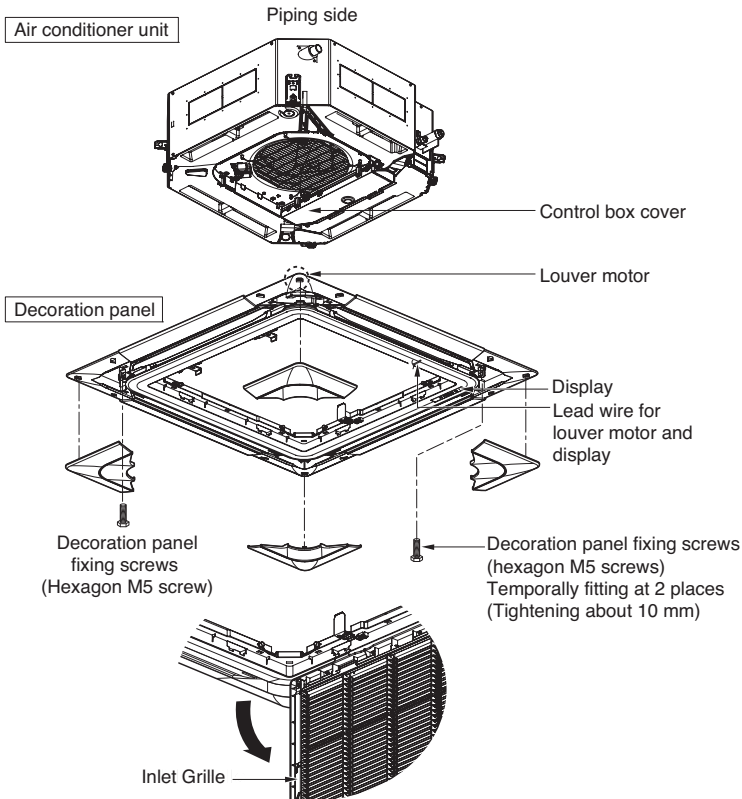

CAUTION

Install certainly the decoration panel.
Cool air leakage causes sweating.
☞ Water drops fall.

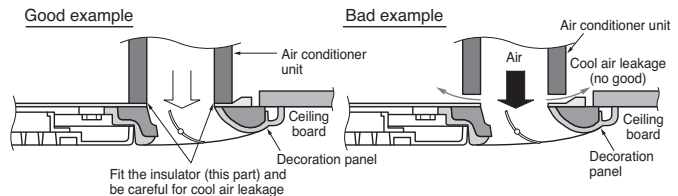

Installation Branch Duct (TM-A 4way)

1. Cut side panel and EPS foam by following perforation on the cabinet. Use nipper to cut the side steel panel and use cutter to cut EPS. (Do not use grinder to cut EPS)



Cut side panels

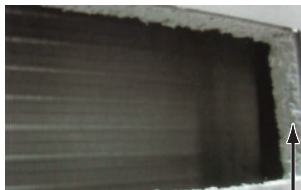

Cut EPS foam

2. Attach insulation precisely to insulate between steel panel and EPS foam. (Recommended material of insulation: PE)



Insulation

! CAUTION

If the outlet(cold) air get into gap of between the steel panel and EPS foam, dew formation would be occurred on the cabinet.

*** Recommended size of insulations**

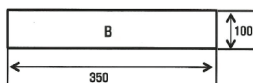
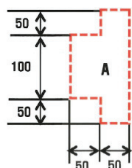
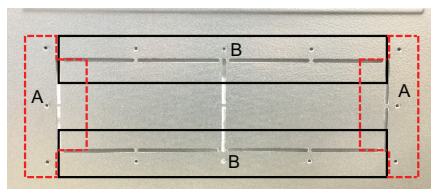

(Unit: mm)

Dimension of insulation

- * This dimension is recommendation. Please apply the fitted size insulation to the Branch Duct hole.
- * Recommended thickness of the insulation: more than 5 mm(0.2 inch).

! CAUTION

If the thickness of insulation is less than 5 mm(0.2 inch), it may cause the dew formation.

3. Install Duct Chamber (Sub Duct) on the cabinet tightly by screws.
If the screws that is used to fix the Duct chamber penetrate the EPS, attach insulation to cover the penetrated screws.

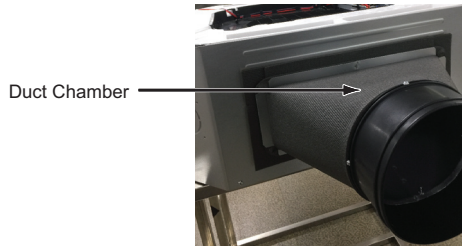

4. Attach insulation to cover the assembled part and the whole cabinet.
(Recommended material of insulation: PE)

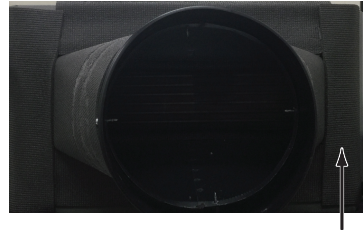

Cover the whole cabinet by insulation

⚠ CAUTION

If the insulation does not cover the whole cabinet, it may cause the dew formation on the cabinet of Indoor unit.

※ Recommended size of insulations

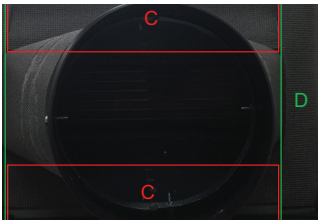

(Unit: mm)

Dimension of insulation

※ This dimension is recommendation. Please apply the fitted size insulation to the cover the whole cabinet.

C : 365mm x 100mm

D : 270mm x 100mm

※ Recommended thickness of the insulation: more than 10 mm.

⚠ CAUTION

If the thickness of insulation is less than 10mm, it may cause the dew formation.

5. Place insulated duct, and use clamp not to leak the air from the connecting point.

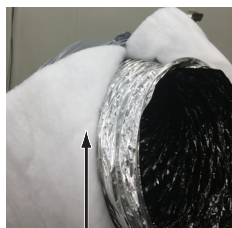

Insulated Duct



Clamp

6. Remove front panel, and use insulation to seal the air outlet of the side where the branch duct is installed.
(Recommended material of insulation: PE)

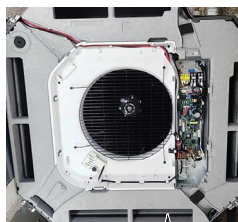

Sealing Insulation

⚠ CAUTION

If the air outlet is not sealed precisely, the air flow of the branch duct would be decreased.

* Recommended size of insulations

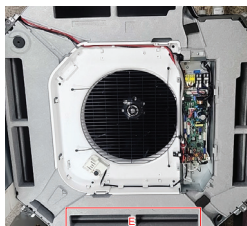

(Unit: mm)

Dimension of insulation

* This dimension is recommendation. Please apply the fitted size insulation to outlet hole.
E : 500mm x 80mm

* Recommended thickness of the insulation:
more than 5 mm.

⚠ CAUTION

If the thickness of insulation is less than 5mm, the dew formation on vane and front panel would be occurred.

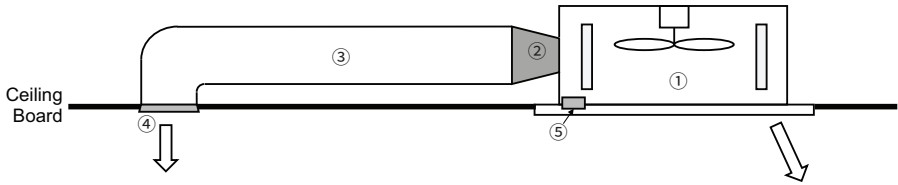

Supplie	① Indoor Unit
Purchased items	② Duct Chamber ③ Duct ④ Diffuser ⑤ Sealing Insulation

1. Duct Chamber (②)

Connection part between indoor unit and duct.

The duct chamber should be covered by insulation.

Thickness of the insulation should be more than 10mm for outside of the duct chamber and 5mm for inside. If the insulators are not thick enough, it may cause the dew formation on the duct chamber.

2. Duct (③)

Recommended diameter of the duct is $\varnothing 200$ mm.

The duct should be insulated or the insulation work should be done.

3. Sealing Insulation (⑤)

Seal an air outlet of the side where the branch duct is installed.

The air outlet should be blocked precisely to prevent air flow decreasing of the branch duct.

⚠ CAUTION

1. If the insulation of duct chamber is not thick enough, it may cause dew formation.
2. If the sealing insulation is not thick enough, it may cause dew formation.
3. If the sealing insulation does not cover the whole outlet hole, it may cause dew formation.

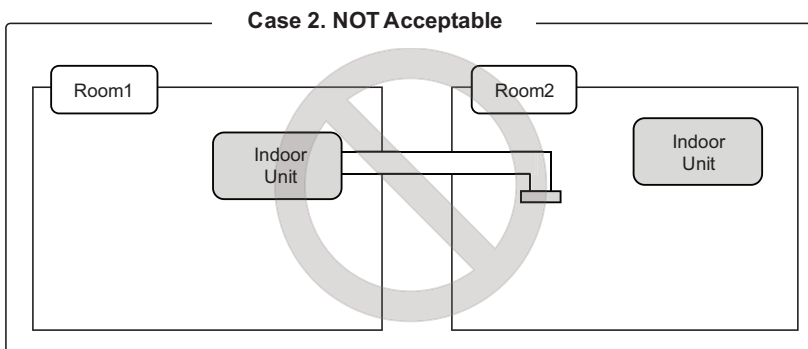
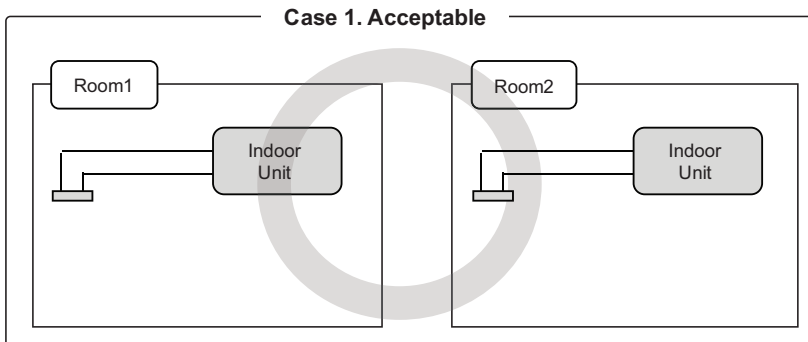

⚠ WARNING

Do not connect the Branch duct to another room.

⚠ CAUTION

1. All the components of the duct should be precisely insulated. when connecting between each component, sealing must be done precisely.
2. When the metal duct penetrates the wooden wall, please electrically insulate between duct and the wall. (Please install plastic sleeve and etc. to insulate.)
3. Do not install the duct as below.

1) To bend the duct excessively



2) To bend the duct too many times



3) To reduce the duct diameter



P-Q Curve of Branch Duct

- Please refer to the below P-Q Curves to install the branch duct

1. 1 side Branch Duct

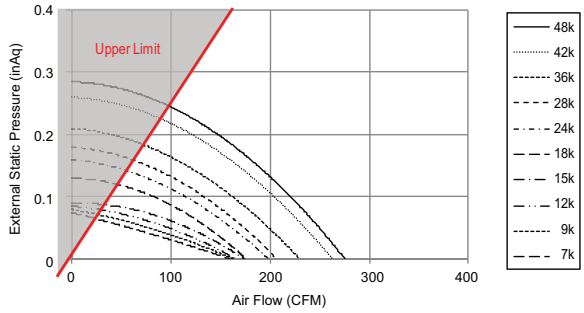
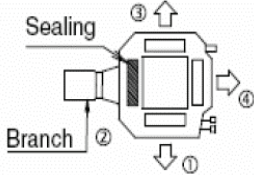

2. 2 sides Branch Ducts

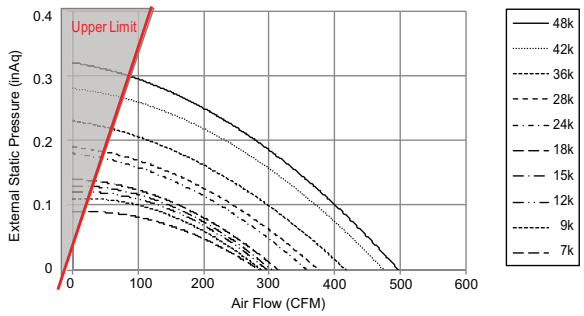
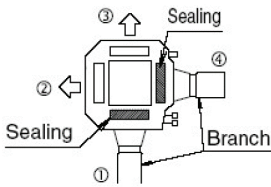

Drain Piping

- Drain piping must have down-slope (1/50 to 1/100): be sure not to provide up-and-down slope to prevent reversal flow.
- During drain piping connection, be careful not to exert extra force on the drain port on the indoor unit.
- The outside diameter of the drain connection on the indoor unit is 32 mm(1-1/4 inch).

Piping material: Polyvinyl chloride pipe inner diametes Ø 25 mm(1 inch) and pipe fittings

- Be sure to install heat insulation on the drain piping.

Heat insulation material: Polyethylene foam with thickness more than 8 mm(5/16 inch).

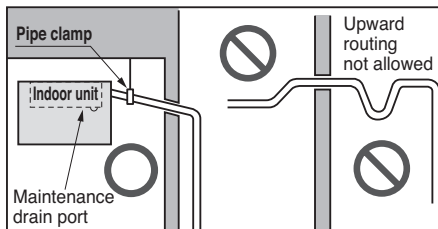

Drain test

The air conditioner uses a drain pump to drain water.

Use the following procedure to test the drain pump operation:

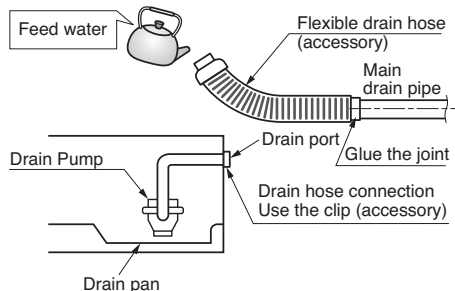

- Connect the main drain pipe to the exterior and leave it provisionally until the test comes to an end.
- Feed water to the flexible drain hose and check the piping for leakage.
- Be sure to check the drain pump for normal operating and noise when electrical wiring is complete.
- When the test is complete, connect the flexible drain hose to the drain port on the indoor unit.

CAUTION

The supplied flexible drain hose should not be curved, neither screwed. The curved or screwed hose may cause a leakage of water.

<Example of drain trap installation>

If 200~300 mm flexible hose is provided

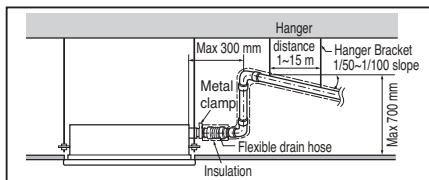

If 800 mm flexible hose is provided

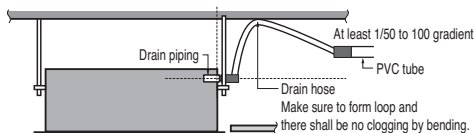

* Product installation and appearance may vary depending on the indoor unit type.

Attention

1. Possible drain-head height is up to 700 mm (27-9/16 inch). So, it must be installed below 700 mm (27-9/16 inch).
2. Keep the drain hose downward up to 1/50~1/100 inclination. Prevent any upward flow or reverse flow in any part.
3. 5 mm (3/16 inch) or thicker formed thermal insulator is provided for the drain pipe.
4. Upward routing is not allowed.
5. Be sure to check the drain pump for normal operation and abnormal noise when electrical wiring is complete.

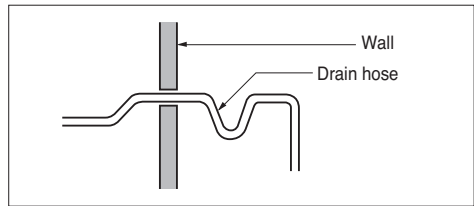
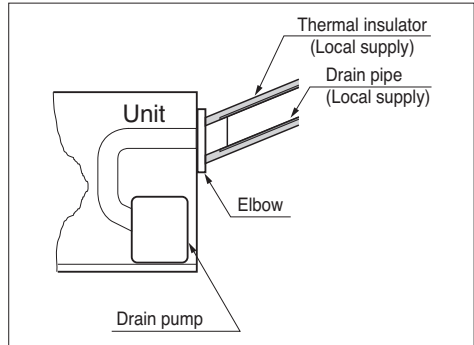
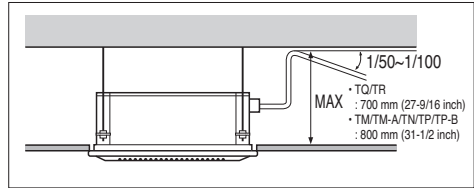

Insulation of drain pipe (1 WAY)

Use the included plastic bands (for drain hose insulation) to seal any gaps in the insulation.

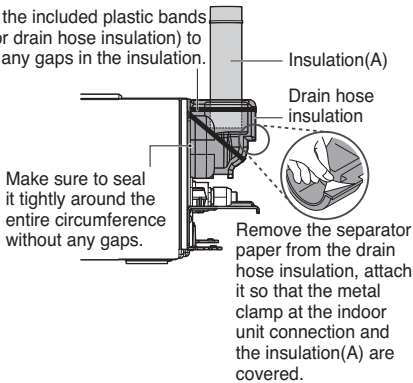

Drain cover installation (1WAY only)

After the plumbing and insulation work, assemble the drain cover as shown below.

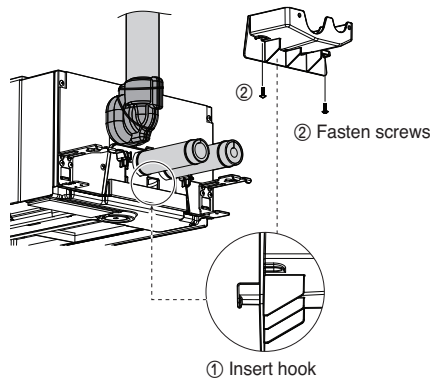

* Please use insulating tape to seal the ends of the insulation well.

Ceiling Height Selection

The ceiling type indoor unit is available to adjust indoor airflow rate by Installer setting of the wired remote controller for better service. Please select the height level from the below table.

<Ceiling Height Selection Table>

Ceiling Height			Selection Level	Description
Below 10.0 kW (Below 34 kBtu/h)	Over 10.0 kW (Over 34 kBtu/h)			
1,2 Way	4 Way	4 Way		
1.8~2.0 m (5.9~6.6 ft)	2.0~2.3 m (6.6~7.5 ft)	2.5~2.7 m (8.2~8.9 ft)	Low	Decrease the indoor airflow rate 1 step from standard level
2.0~2.4 m (6.6~7.9 ft)	2.3~2.7 m (7.5~8.9 ft)	2.7~3.2 m (8.9~10.5 ft)	Standard	Set the indoor airflow rate as standard level
2.4~2.8 m (7.9~9.8 ft)	2.7~3.1 m (8.9~10.2 ft)	3.2~3.6 m (10.5~11.8 ft)	High	Increase indoor airflow rate 1 step from standard level
2.8~3.3m (9.8~10.8 ft)	3.1~3.6 m (10.2~11.8 ft)	3.6~4.2 m (11.8~13.8 ft)	Super high	Increase indoor airflow rate 2 steps from standard level

Ceiling height of 'Very high' function may not exist depending on the indoor unit.

For the details, refer to the product manual.

DIP Switch Setting

	Function	Description	Setting Off	Setting On	Default
SW1	Communication	N/A(Default)	-	-	Off
SW2	Communication	Selection of Using 485 PCB	Not use 485 PCB	Use 485 PCB	Off/On*
SW3	Group Control	Selection of Master or Slave	Master	Slave	Off
SW4	Dry Contact Mode	Selection of Dry Contact Mode	Wired/Wireless remote controller Selection of Manual or Auto operation Mode	Auto	Off
SW5	Installation	N/A(Default)	-	-	Off
SW6	Installation	N/A(Default)	-	-	Off
SW7	Ventilator linkage	Selection of Ventilator linkage	Linkage Removal	Working	Off
SW8	Safety	Leak Detection System	Not installed	Installed	On

⚠ CAUTION

- For Multi V CST Models(except Mini-4Way), DIP Switch 1,2,5,6 must be OFF and 8 must be on.
- For Mini-4Way Models(TQ/TR), DIP Switch 1,5,6 must be OFF and 2, 8 must be on.

Group Control Setting

⚠ CAUTION

If you want to use the two setpoint function, you should be installed the new thermostat.

* Model name of wired remote controller called New thermostat : PREMTB10U

1. Group Control 1

■ Wired remote controller 1 + Standard Indoor Units

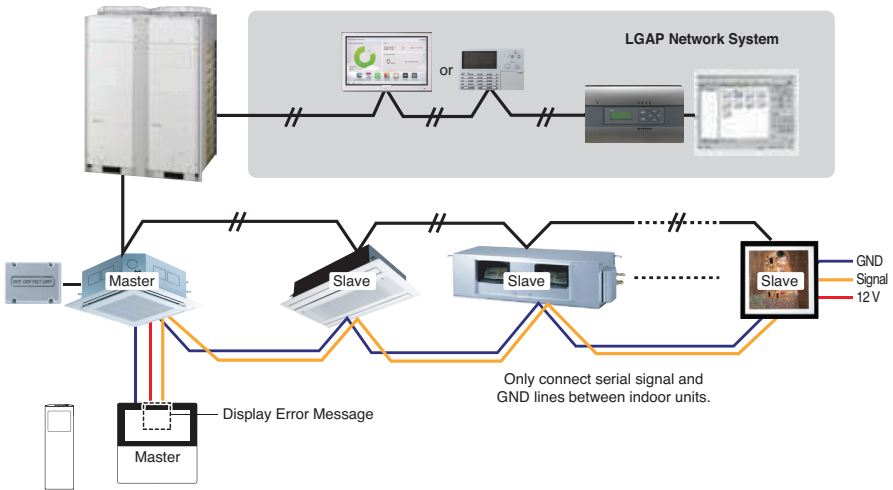

■ DIP Switch in PCB

① Master Setting - No. 3 Off

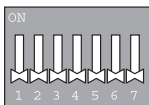

② Slave Setting - No. 3 On

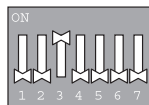

Indoor Unit DIP Switch

Some products have no DIP switch on PCB. It is possible to set indoor units to Master or Slave by using the wireless remote controller instead of DIP switch.

For the details of the setting, please refer to the manual of the wireless remote controller.

1. It is possible to 16 indoor units(Max.) by one wired remote controller.
Set only one indoor unit to Master, set the others to Slave.
2. It is possible to connect with every type of indoor units.
3. It is possible to use wireless remote controller at the same time.
4. It is possible to connect with Dry Contact and Central controller at the same time.
- The Master indoor unit is possible to recognize Dry Contact and Central Controller only.
5. In case that any error occurs at indoor unit, the error code is displayed on the wired remote controller.
It is possible to control the other indoor units except the error units.

* It can be the cause of malfunctions when there is no setting of master and slave.

* In case of Group Control, it is possible to use following functions.

- Selection of operation, stop or mode
- Temperature setting and room temperature check
- Current time change
- Control of flow rate (High/Middle/Low)
- Reservation settings

It is not possible to use some functions.

2. Group Control 2

■ Wired remote controllers + Standard Indoor Units

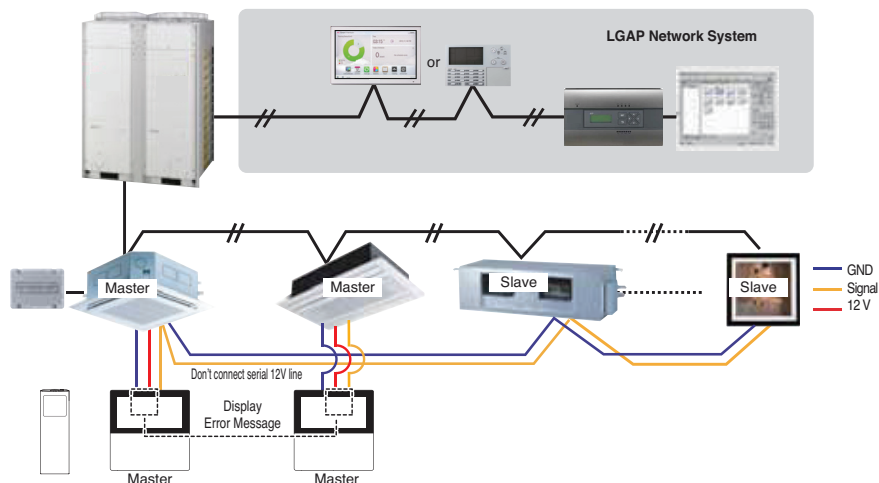

* It is possible to control 16 indoor units(Max.) with the master wired remote control.

* Other than those, it is same with the Group Control 1.

3. Group Control 3

■ Mixture connection with indoor units and Fresh Air Intake Unit

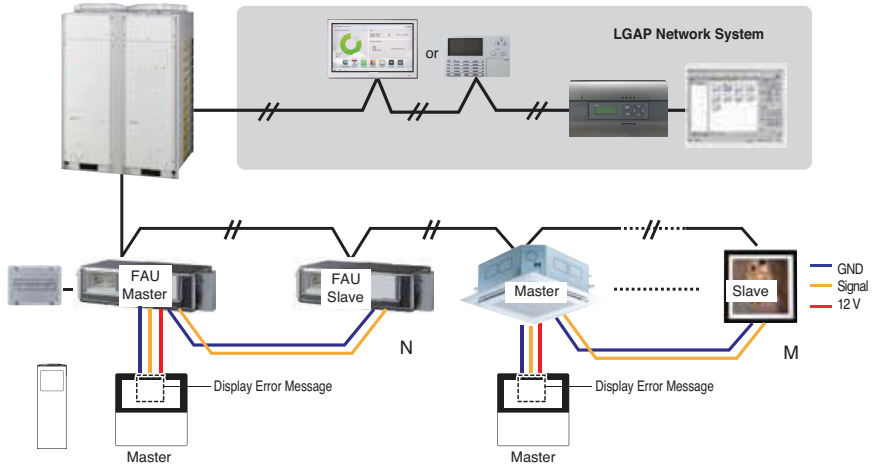

※ In case of connecting with standard indoor unit and Fresh Air Intake Unit, separate Fresh Air Intake Unit with standard units. (N, M ≤ 16) (Because setting temperature are different.)

※ Other than those, it is same with Group Control 1.



* FAU : Fresh Air Intake Unit
Standard: Standard Indoor Unit

4. 2 Remote Control

■ Wired remote controller 2 + Indoor unit 1

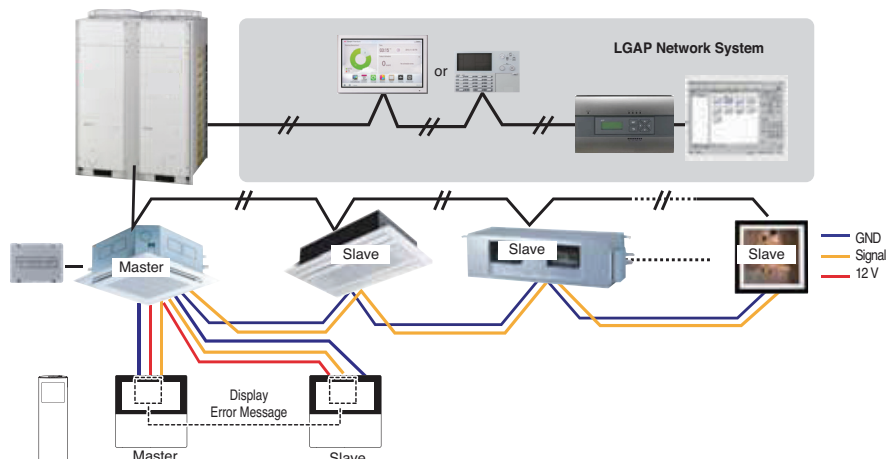

1. It is possible to connect two wired remote controllers (Max.) with one indoor unit.

Set only one indoor unit to Master, set the others to Slave.

Set only one wired remote controller to Master, set the others to Slave.

2. Every types of indoor unit is possible to connect two remote controller.

3. It is possible to use wireless remote controller at the same time.

4. It is possible to connect with Dry Contact and Central controller at the same time.

5. In case that any error occurs at indoor unit, the error code is displayed on the wired remote controller.

6. There isn't limits of indoor unit function.

5. Accessories for group control setting

It is possible to set group control by using below accessories.

Indoor unit 2 EA + Wired remote controller 1 EA	Indoor unit 1 EA +Wired remote controller 2 EA
<p>※ PZCWRCG3 cable used for connection</p>	<p>※ PZCWRC2 cable used for connection</p>

⚠ CAUTION

Apply totally enclosed noncombustible conduit in case of local building code Requiring plenum cable usage.

Airborne Noise Emission

The A-weighted sound pressure emitted by this product is below 70 dB.

** The noise level can vary depending on the site.

The figures quoted are emission level and are not necessarily safe working levels. Whilst there is a correlation between the emission and exposure levels, this cannot be used reliably to determine whether or not further precautions are required. Factors that influence the actual level of exposure of the workforce include the characteristics of the work room and the other sources of noise, i.e. the number of equipment and other adjacent processes and the length of time for which an operator is exposed to the noise. Also, the permissible exposure level can vary from country to country. This information, however, will enable the user of the equipment to make a better evaluation of the hazard and risk.

R32 Leak Detection System

The R32 refrigerant leak detector detects the concentration of refrigerant (R32) in the air. When the concentration of refrigerant in the air is 5 000 ppm or higher, the Leak Detection system will be activated. If the Leak Detection system is activated, the following actions will be operated automatically:

- Wired remote controller and indoor units display an Error code and R32 Sensor Sub PCB issues an alarm so that the user realizes that there is a refrigerant leak. (The alarm function is only available in some products)
- The fan of the indoor unit where the error code is displayed will turn on.
- The unit cannot be used until the error code disappears.

WARNING

- If there are error codes such as 228, 229 and 230, ventilate the room and contact authorized personnel immediately.
- If there is an error code of 236, the refrigerant leak detector has a lifetime of less than 6 months. Contact authorized personnel immediately.
- The R32 refrigerant detector must be replaced after detecting any gases or at the end of its lifetime (3650 days).
- Refrigerant leak detectors for the Leak Detection System shall only be replaced with detectors specified by the appliance manufacturer.
- R32 Leak detection system replacement shall be carried out by authorized personnel only.
- There is a possibility of detecting other gases, not R32. Do not use highly concentrated chemicals (e.g. Ethanol, Smoke, Hair spray and pesticide) near the indoor unit. R32 refrigerant leakage sensor may detect incorrectly.

Troubleshooting

Error Code	Error Type	Error point	Main reasons
CH 228	Refrigerant leak detector malfunction error	Refrigerant leak detector has failed.	<ul style="list-style-type: none"> • The sensor is breaking of short. • Abnormal voltage of DC converter. • Abnormal operation of microprocessor.

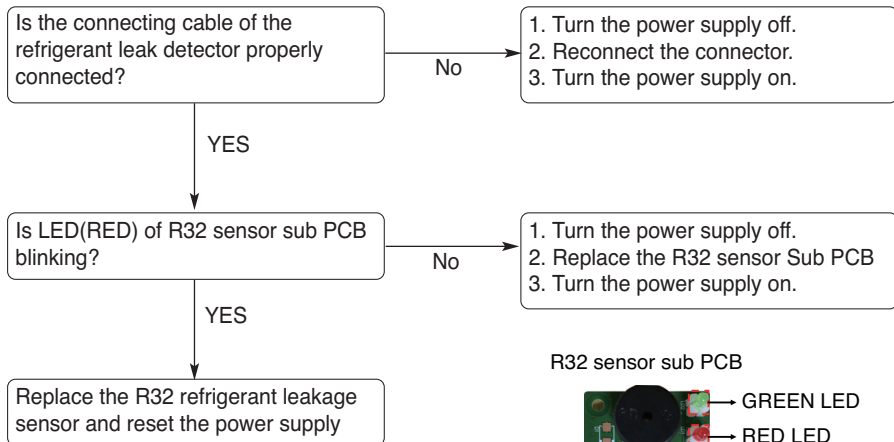

R32 sensor sub PCB

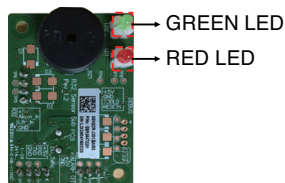

Error Code	Error Type	Error point	Main reasons
CH 229	Refrigerant leak detector lifetime error	The lifetime of the refrigerant leak detector has reached the end	<ul style="list-style-type: none"> • The lifetime of the refrigerant leak detector has been reached, so replace the sensor.

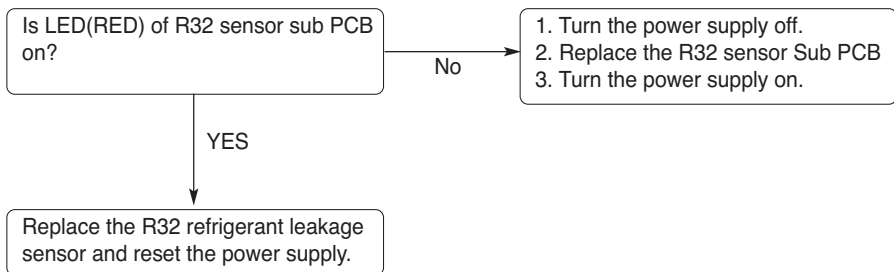

Error Code	Error Type	Error point	Main reasons
CH 230	Refrigerant leak detection error	Refrigerant leak detected by refrigerant leak detector.	<ul style="list-style-type: none"> Refrigerant leak detection

Reset the power supply
Is the error code displayed again?

No

No refrigerant leakage detected.
The system resumes normal operation

YES

Is there any leakage points in the refrigerant system?

YES

Check the installation status of outdoor and indoor units and fix it. Replace the R32 refrigerant leakage sensor.
If the sensor detects any gases once, it may malfunction because it is semiconductor type detector.

Error Code	Error Type	Error point	Main reasons
CH 236	Refrigerant leak detector lifetime pre-alarm	An error occurs once a month when the lifespan of the leak detector has elapsed 9 years and 6 months. An error occurs once a day when the lifespan of the leak detector has elapsed 9 years and 11 months.	<ul style="list-style-type: none"> The refrigerant leak detector has 10 years lifespan.

When press any button on the remote controller, the error code will disappear. Does this error occur next day again?

No

The refrigerant leak detector has a lifetime of more than 1 month and less than 6 months. It is recommended to replace the R32 refrigerant leak detector.

YES

The refrigerant leak detector has a lifetime of less than 1 month. Replace the R32 refrigerant leak detector immediately.



US	Please call the installing contractor of your product, as warranty service will be provided by them.
CANADA	Service call Number # : (888) LG Canada, (888) 542-2623 Numéro pour les appels de service : LG Canada, 1-888-542-2623