



INSTALLATION MANUAL

AIR CONDITIONER

Please read this installation manual completely before installing the product. Installation work must be performed in accordance with the national wiring standards by authorized personnel only. Please retain this installation manual for future reference after reading it thoroughly.

Ceiling Concealed Duct
Original instruction



MFL67939930
Rev.06_102925

Copyright © 2017 - 2025 LG Electronics Inc. All Rights Reserved.



www.lg.com

РУССКИЙ ЯЗЫК

ENGLISH

УКРАЇНЬСЬКА

ITALIANO

ҚАЗАҚ ТІЛІ

ESPAÑOL

БЕЛІҢҮСҚАҢАҢДЫ

FRANÇAIS

ЎЗБЕК ТИЛИ

DEUTSCH

ΕΛΛΗΝΙΚΑ

ČEŠTINA

NEDERLANDS

POLSKI

LIMBA ROMÂNĂ

MODEL DESIGNATION

Product information

- Product Name : Air conditioner

- Model Name :

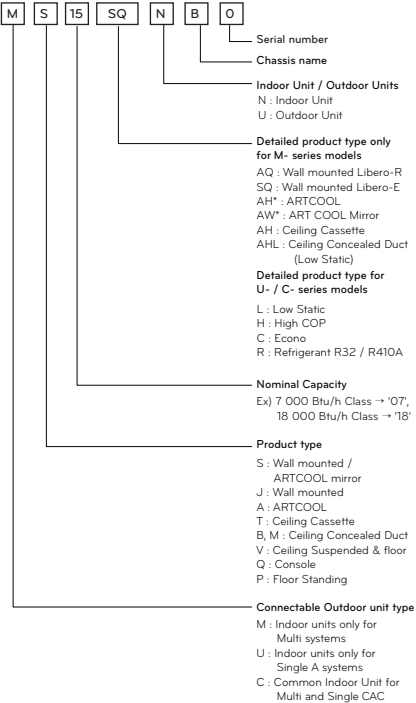

- Additional Information : serial number is refer to the barcode on the product.

- Maximum allowable pressure High side : 4.2 MPa / 4.32 MPa (it can be different by model)

Maximum allowable pressure Low side : 2.4 MPa

- Refrigerant : R32

Airborne Noise Emission

The A-weighted sound pressure emitted by this product is below 70 dB.

** The noise level can vary depending on the site.

The figures quoted are emission level and are not necessarily safe working levels.

Whilst there is a correlation between the emission and exposure levels, this cannot be used reliably to determine whether or not further precautions are required.

Factor that influence the actual level of exposure of the workforce include the characteristics of the work room and the other sources of noise, i.e. the number of equipment and other adjacent processes and the length of time for which an operator exposed to the noise. Also, the permissible exposure level can vary from country to country.

This information, however, will enable the user of the equipment to make a better evaluation of the hazard and risk.

Limiting concentration

Limiting concentration is the limit of Freon gas concentration where immediate measures can be taken without hurting human body when refrigerant leaks in the air. The limiting concentration shall be described in the unit of kg/m^3 (Freon gas weight per unit air volume) for facilitating calculation

Limiting concentration: $0.44 \text{ kg}/\text{m}^3(\text{R410A})$

■ Calculate refrigerant concentration

$$\text{Refrigerant concentration (kg}/\text{m}^3) = \frac{\text{Total amount of replenished refrigerant in refrigerant facility (kg)}}{\text{Capacity of smallest room where indoor unit is installed (m}^3)}$$

TIPS FOR SAVING ENERGY

Here are some tips that will help you minimize the power consumption when you use the air conditioner.

You can use your air conditioner more efficiently by referring to the instructions below:

- Do not cool excessively indoors. This may be harmful for your health and may consume more electricity.
- Block sunlight with blinds or curtains while you are operating the air conditioner.
- Keep doors or windows closed tightly while you are operating the air conditioner.
- Adjust the direction of the air flow vertically or horizontally to circulate indoor air.
- Speed up the fan to cool or warm indoor air quickly, in a short period of time.
- Open windows regularly for ventilation as the indoor air quality may deteriorate if the air conditioner is used for many hours.
- Clean the air filter once every 2 weeks. Dust and impurities collected in the air filter may block the air flow or weaken the cooling / dehumidifying functions.

For your records

Staple your receipt to this page in case you need it to prove the date of purchase or for warranty purposes.

Write the model number and the serial number here:

Model number : _____

Serial number : _____





You can find them on a label on the side of each unit.

Dealer's name : _____

Date of purchase : _____

IMPORTANT SAFETY INSTRUCTIONS

The following symbols are displayed on indoor and outdoor units.

	Read the precautions in this manual carefully before operating the unit.		This appliance is filled with flammable refrigerant (R32)
	This symbol indicates that the Operation Manual should be read carefully.		This symbol indicates that a service personnel should be handling this equipment with reference to the Installation Manual.

READ ALL INSTRUCTIONS BEFORE USING THE APPLIANCE.

Always comply with the following precautions to avoid dangerous situations and ensure peak performance of your product.

! WARNING

It can result in serious injury or death when the directions are ignored.

! CAUTION

It can result in minor injury or product damage when the directions are ignored.

! WARNING

- Installation or repairs made by unqualified persons can result in hazards to you and others.
- The information contained in the manual is intended for use by a qualified service technician familiar with safety procedures and equipped with the proper tools and test instruments.
- Failure to carefully read and follow all instructions in this manual can result in equipment malfunction, property damage, personal injury and/or death.
- Compliance with national gas regulations shall be observed.
- Ducts connected to an appliance shall not contain an ignition source. (for R32)

Installation

- Always perform grounding.
 - Otherwise, it may cause electrical shock.
- Don't use a power cord, a plug or a loose socket which is damaged.
 - Otherwise, it may cause a fire or electrical shock.
- For installation of the product, always contact the service center or a professional installation agency.
 - Otherwise, it may cause a fire, electrical shock, explosion or injury.
- Securely attach the electrical part cover to the indoor unit and the service panel to the outdoor unit.
 - If the electrical part cover of the indoor unit and the service panel of the outdoor unit are not attached securely, it could result in a fire or electric shock due to dust, water, etc.
- Always install an air leakage breaker and a dedicated switching board.
 - No installation may cause a fire and electrical shock.
- Do not keep or use flammable gases or combustibles near the air conditioner.
 - Otherwise, it may cause a fire or the failure of product.
- Ensure that an installation frame of the outdoor unit is not damaged due to use for a long time.
 - It may cause injury or an accident.
- Do not disassemble or repair the product randomly.
 - It will cause a fire or electrical shock.
- Do not install the product at a place that there is concern of falling down.
 - Otherwise, it may result in personal injury.
- Use caution when unpacking and installing.
 - Sharp edges may cause injury.

- The appliance shall be stored in a room without continuously operating ignition sources (for example: open flames, an operating gas appliance or an operating electric heater.)
- Two or more people must lift and transport the product. Avoid personal injury.
- Do not use means to accelerate the defrosting process or to clean, other than those recommended by the manufacturer.
- Do not pierce or burn refrigerant cycle part.
- Be aware that refrigerants may not contain an odour.
- Keep any required ventilation openings clear of obstruction.
- The appliance shall be stored in a well-ventilated area where the room size corresponds to the room area as specified for operation. (for R32)
- Refrigerant tubing shall be protected or enclosed to avoid damage.
- Flexible refrigerant connectors (such as connecting lines between the indoor and outdoor unit) that may be displaced during normal operations shall be protected against mechanical damage.
- A brazed, welded, or mechanical connection shall be made before opening the valves to permit refrigerant to flow between the refrigerating system parts.
- Mechanical connections shall be accessible for maintenance purposes.
- The appliance shall be disconnected from its power source during service and when replacing parts.
- The appliance shall be installed in accordance with national wiring regulations.

Operation

- Do not share the outlet with other appliances.
 - It will cause an electric shock or a fire due to heat generation.
- Do not use the damaged power cord.
 - Otherwise, it may cause a fire or electrical shock.
- Do not modify or extend the power cord randomly.
 - Otherwise, it may cause a fire or electrical shock.
- Take care so that the power cord may not be pulled during operation.
 - Otherwise, it may cause a fire or electrical shock.
- Unplug the unit if strange sounds, smell, or smoke comes from it.
 - Otherwise, it may cause electrical shock or a fire.
- Keep the flames away.
 - Otherwise, it may cause a fire.
- Take the power plug out if necessary, holding the head of the plug and do not touch it with wet hands.
 - Otherwise, it may cause a fire or electrical shock.
- Do not use the power cord near the heating tools.
 - Otherwise, it may cause a fire and electrical shock.
- Do not open the suction inlet of the indoor/outdoor unit during operation.
 - Otherwise, it may electrical shock and failure.
- Do not allow water to run into electrical parts.
 - Otherwise, it may cause the failure of machine or electrical shock.
- Hold the plug by the head when taking it out.
 - It may cause electric shock and damage.
- Never touch the metal parts of the unit when removing the filter.
 - They are sharp and may cause injury.

- Do not step on the indoor/outdoor unit and do not put anything on it.
 - It may cause an injury through dropping of the unit or falling down.
- Do not place a heavy object on the power cord.
 - Otherwise, it may cause a fire or electrical shock.
- When the product is submerged into water, always contact the service center.
 - Otherwise, it may cause a fire or electrical shock.
- Take care so that children may not step on the outdoor unit.
 - Otherwise, children may be seriously injured due to falling down.
- Use a vacuum pump or inert (nitrogen) gas when doing leakage test or air purge. Do not compress air or oxygen, and do not use flammable gases. Otherwise, it may cause fire or explosion.
 - There is the risk of death, injury, fire or explosion.
- Do not turn on the breaker or power under condition that front panel, cabinet, top cover, control box cover are removed or opened.
 - Otherwise, it may cause fire, electric shock, explosion or death.
- Turn off all devices that cause fire when the refrigerant leaks., ventilate the room (example : opening window or using ventilation unit), and contact with dealer who you purchased the unit.
- The installation of pipe-work shall be kept to a minimum.
- When mechanical connectors are reused indoors, sealing parts shall be renewed. (for R32)
- When flared joints are reused indoors, the flare part shall be re-fabricated. (for R32)

CAUTION

Installation

- Install the drain hose to ensure that drain can be securely done.
 - Otherwise, it may cause water leakage.
- Install the product so that the noise or hot wind from the outdoor unit may not cause any damage to the neighbors.
 - Otherwise, it may cause dispute with the neighbors.
- Always inspect gas leakage after the installation and repair of product.
 - Otherwise, it may cause the failure of product.
- Keep level parallel in installing the product.
 - Otherwise, it may cause vibration or water leakage.
- Any person who is involved with working on or breaking into a refrigerant circuit should hold a current valid certificate from an industry-accredited assessment authority, which authorises their competence to handle refrigerants safely in accordance with an industry recognised assessment specification. (for R32)
- Wear adequate personal protection equipment (PPE) when installing, maintaining or servicing the product.
- Pipe-work shall be protected from physical damage.
- Do not install the unit in potentially explosive atmospheres.

Operation

- Avoid excessive cooling and perform ventilation sometimes.
 - Otherwise, it may do harm to your health.
- Use a soft cloth to clean. Do not use wax, thinner, or a strong detergent.
 - The appearance of the air conditioner may deteriorate, change color, or develop surface flaws.

- Do not use an appliance for special purposes such as preserving animals vegetables, precision machine, or art articles.
 - Otherwise, it may damage your properties.
- Do not place obstacles around the flow inlet or outlet.
 - Otherwise, it may cause the failure of appliance or an accident.
- The appliance shall be stored so as to prevent mechanical damage from occurring.
- Servicing shall only be performed as recommended by the equipment manufacturer. Maintenance and repair requiring the assistance of other skilled personnel shall be carried out under the supervision of the person competent in the use of flammable refrigerants. (for R32)
- Dismantling the unit, treatment of the refrigerant oil and eventual parts should be done in accordance with local and national standards.
- Periodic (more than once/year) cleaning of the dust or salt particles stuck on the heat exchanger by using water.
- Means for disconnection must be incorporated in the fixed wiring in accordance with the wiring rules.

TABLE OF CONTENTS

2 MODEL DESIGNATION

3 TIPS FOR SAVING ENERGY

4 IMPORTANT SAFETY INSTRUCTIONS

12 INSTALLATION PLACES

14 THE INDOOR UNIT INSTALLATION

14 Position of suspension Bolt

17 Wiring Connection

19 Flaring Work

22 REMOTE CONTROLLER INSTALLATION

24 Wired remote controller installation

25 OPTIONAL OPERATION

25 Installer Setting - Test Run Mode

26 Installer Setting - Setting Address of Central Control

27 Installer Setting - Thermistor

28 Installer Setting - Ceiling Height Selection

29 Installer Setting - Group Setting

30 Installer Setting - Dry Contact Mode Setting

31 Installer Setting - Celsius / Fahrenheit Switching

32 Installer Setting - Optional Function Setting

33 Installer Setting - Remote controller Mode Lock

34 HOW TO SET E.S.P?

34 Installer Setting - E.S.P.

36 Installer Setting - Static Pressure Step Setting

41 Installer Setting - Auto ESP

44 SELF-DIAGNOSIS FUNCTION

45 DIP SWITCH SETTING

INSTALLATION PLACES

Install the air conditioner in the location that satisfies the following conditions.

- The place shall easily bear a load exceeding four times the indoor unit's weight.
- The place shall be able to inspect the unit as the figure.
- The place where the unit shall be leveled.
- The place shall allow easy water drainage.
(Suitable dimension "H" is necessary to get a slope to drain as figure.)
- The place shall easily connect with the outdoor unit.
- The place where the unit is not affected by an electrical noise.
- The place where air circulation in the room will be good.
- There should not be any heat source or steam near the unit.

Ceiling Concealed Duct – Low Static

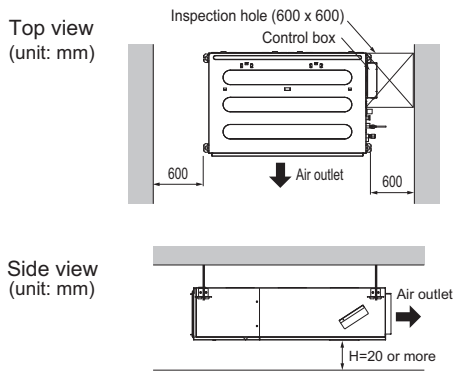

- Suitable dimension "H" is necessary to get a slope to drain as shown in the figure

Ceiling Concealed Duct – Mid Static

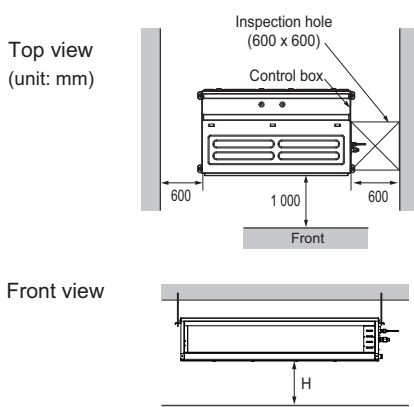

⚠ CAUTION

- In case that the unit is installed near the sea, the installation parts may be corroded by salt. The installation parts (and the unit) should be taken appropriate anti-corrosion measures.

[Inspection Hole Standard]

Number of Inspection hole	Distance between False ceiling & Actual ceiling	Remarks
1	More than 100 cm	Sufficient space in the ceiling for servicing.
2	20 cm to 100 cm	Insufficient space. Difficult for servicing
Hole size should be more than the size of IDU.	Less than 20 cm	Minimum height for motor replacement.

Minimum floor area (for R32)

- The appliance shall be installed, operated and stored in a room with a floor area larger than the minimum area.
- Use the graph of table to determine the minimum area.

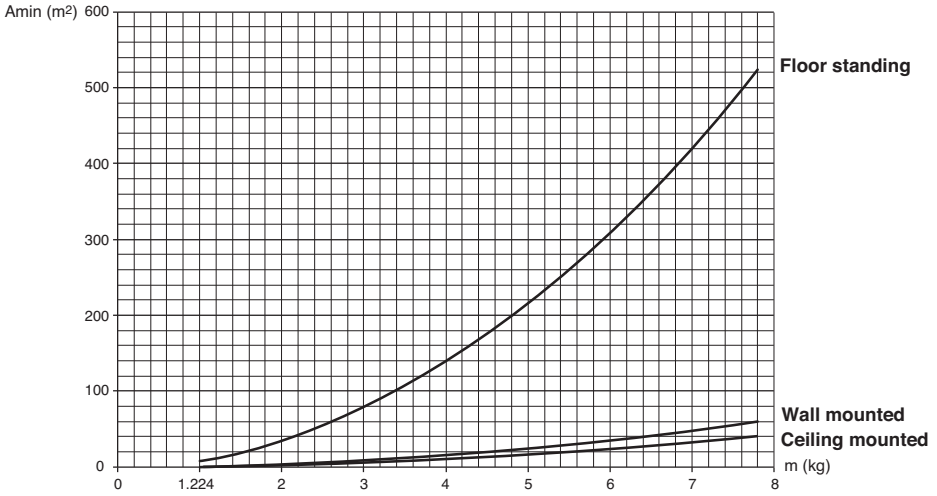

- m : Total refrigerant amount in the system
- Total refrigerant amount : factory refrigerant charge + additional refrigerant amount
- Amin : minimum area for installation

Floor location		Floor location		Wall mounted		Wall mounted		Ceiling Mounted		Ceiling Mounted	
m (kg)	Amin (m ²)	m (kg)	Amin (m ²)	m (kg)	Amin (m ²)	m (kg)	Amin (m ²)	m (kg)	Amin (m ²)	m (kg)	Amin (m ²)
< 1.224	-	4.6	181.56	< 1.224	-	4.6	20.17	< 1.224	-	4.6	13.50
1.224	12.9	4.8	197.70	1.224	1.43	4.8	21.97	1.224	0.956	4.8	14.70
1.4	16.82	5	214.51	1.4	1.87	5	23.83	1.4	1.25	5	15.96
1.6	21.97	5.2	232.02	1.6	2.44	5.2	25.78	1.6	1.63	5.2	17.26
1.8	27.80	5.4	250.21	1.8	3.09	5.4	27.80	1.8	2.07	5.4	18.61
2	34.32	5.6	269.09	2	3.81	5.6	29.90	2	2.55	5.6	20.01
2.2	41.53	5.8	288.65	2.2	4.61	5.8	32.07	2.2	3.09	5.8	21.47
2.4	49.42	6	308.90	2.4	5.49	6	34.32	2.4	3.68	6	22.98
2.6	58.00	6.2	329.84	2.6	6.44	6.2	36.65	2.6	4.31	6.2	24.53
2.8	67.27	6.4	351.46	2.8	7.47	6.4	39.05	2.8	5.00	6.4	26.14
3	77.22	6.6	373.77	3	8.58	6.6	41.53	3	5.74	6.6	27.80
3.2	87.86	6.8	396.76	3.2	9.76	6.8	44.08	3.2	6.54	6.8	29.51
3.4	99.19	7	420.45	3.4	11.02	7	46.72	3.4	7.38	7	31.27
3.6	111.20	7.2	444.81	3.6	12.36	7.2	49.42	3.6	8.27	7.2	33.09
3.8	123.90	7.4	469.87	3.8	13.77	7.4	52.21	3.8	9.22	7.4	34.95
4	137.29	7.6	495.61	4	15.25	7.6	55.07	4	10.21	7.6	36.86
4.2	151.36	7.8	522.04	4.2	16.82	7.8	58.00	4.2	11.26	7.8	38.83
4.4	166.12			4.4	18.46			4.4	12.36		

THE INDOOR UNIT INSTALLATION

Position of suspension Bolt

- Apply a joint-canvas between the unit and duct to absorb unnecessary vibration.
- Apply a filter Accessory at air return hole.

Ceiling Concealed Duct – Low Static

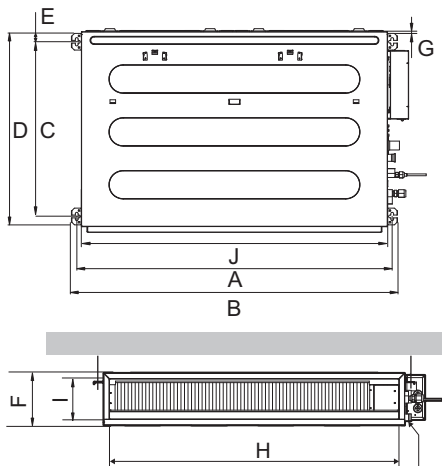

Drainage hole
(Unit: mm)

Dimension Capacity (kBtu/h)	A	B	C	D	E	F	G	H	I	J
9	733	772	628	700	36	190	20	660	155	700
12/18	933	972	628	700	36	190	20	860	155	900
24	1 133	1 172	628	700	36	190	20	1 060	155	1 100

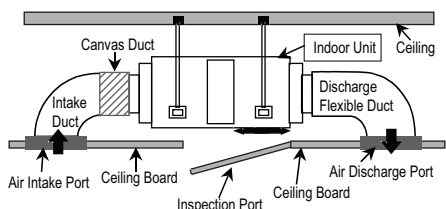

Ceiling Concealed Duct – Mid Static

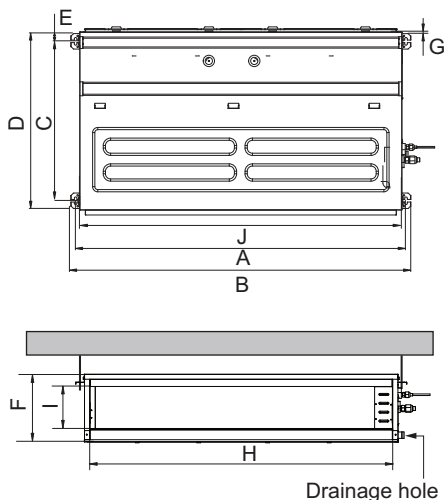

Drainage hole

(Unit: mm)

Dimension Capacity (kBtu/h)	A	B	C	D	E	F	G	H	I	J
18 / 24 / 30	933.4	971.6	619.2	700	30	270	15.2	858	201.4	900
36 / 42	1 283.4	1 321.6	619.2	689.6	30	270	15.2	1 208	201.4	1 250
48 / 60	1 283.4	1 321.6	619.2	689.6	30	360	15.2	1 208	291.4	1 250

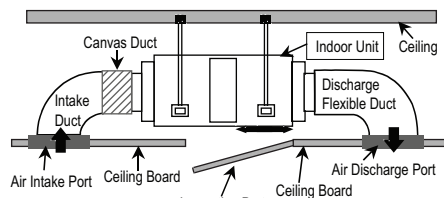

- Select and mark the position for fixing bolts and piping hole.
- Decide the position for fixing bolts slightly tilted to the drain direction after considering the direction of drain hose.
- Drill the hole for anchor bolt on the wall.

CAUTION

- This air-conditioner uses a drain pump.
- Install the unit horizontally using a level gauge.
- During the installation, care should be taken not to damage electric wires.

NOTE

Avoid the following installation location.

- 1 Such places as restaurants and kitchen where considerable amount of oil steam and flour is generated. These may cause heat exchange efficiency reduction, or water drops, drain pump mal-function. In these cases, take the following actions;
 - Make sure that ventilation fan is enough to cover all noxious gases from this place.
 - Ensure enough distance from the cooking room to install the air conditioner in such a place where it may not suck oily steam.
- 2 Avoid installing air conditioner in such places where cooking oil or iron powder is generated.
- 3 Avoid places where inflammable gas is generated.
- 4 Avoid place where noxious gas is generated.
- 5 Avoid places near high frequency generators.

Install the unit leaning to a drainage hole side as a figure for easy water drainage.

Position of console Bolt

- A place where the unit will be leveled and that can support the weight of the unit.
- A place where the unit can withstand its vibration.
- A place where service can be easily performed.

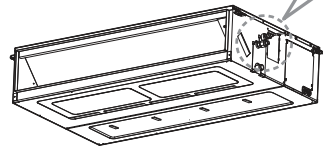
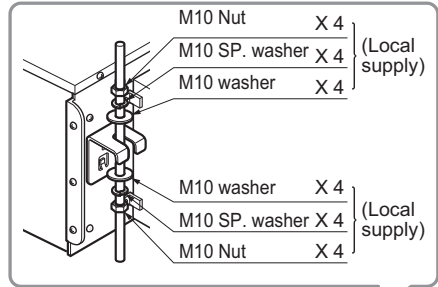

- Select and mark the position for fixing bolts.
- Drill the hole for set anchor on the face of ceiling.

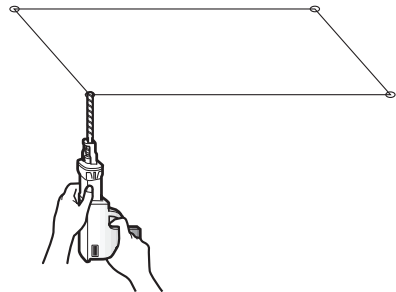

- Insert the set anchor and washer onto the suspension bolts for locking the suspension bolts on the ceiling.
- Mount the suspension bolts to the set anchor firmly.
- Secure the installation plates onto the suspension bolts (adjust level roughly) using nuts, washers and spring washers.

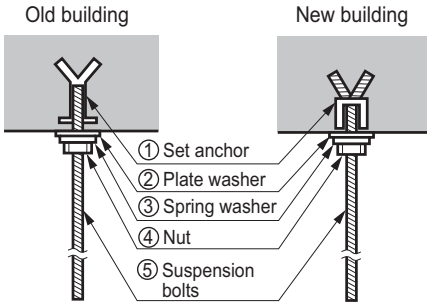

- Local supply
 - ① Set anchor
 - ② Plate washer - M10
 - ③ Spring washer - M10
 - ④ Nut - W3/8 or M10
 - ⑤ Suspension bolt - W3/8 or M10

CAUTION

- Tighten the nut and bolt to prevent unit falling.

CAUTION

1. Install declination of the indoor unit is very important for the drain of the duct type airconditioner.
2. Minimum thickness of the insulation for the connecting pipe shall be 10 mm.

Front of view

- The unit must be horizontal or declined to the drain hose connected when finished installation.

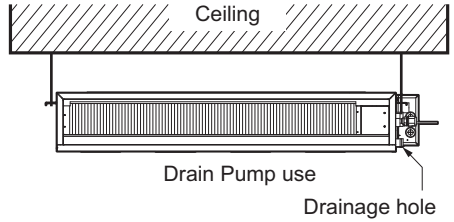

Ceiling Concealed Duct – Low static

- The unit must be declined to the drain hose connected when finished installation.

CORRECT

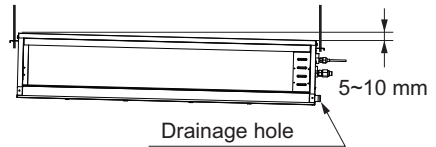

INCORRECT

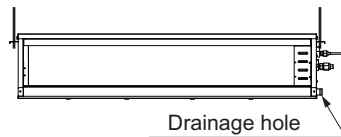

Ceiling Concealed Duct – Mid static

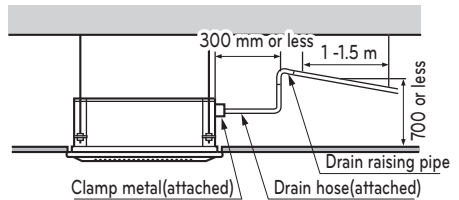

Heat insulation material: Polyethylene foam with thickness more than 8 mm.

Drain test

The air conditioner uses a drain pump to drain water.

Use the following procedure to test the drain pump operation:

- Connect the main drain pipe to the exterior and leave it provisionally until the test comes to an end.
- Feed water to the flexible drain hose and check the piping for leakage.
- Be sure to check the drain pump for normal operating and noise when electrical wiring is complete.
- When the test is complete, connect the flexible drain hose to the drain port on the indoor unit.

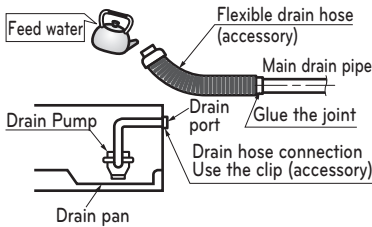

CAUTION

The supplied flexible drain hose should not be curved, neither screwed. The curved or screwed hose may cause a leakage of water.

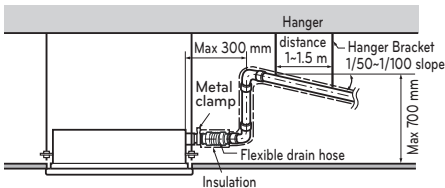

HEAT INSULATION

- Use the heat insulation material for the refrigerant piping which has an excellent heat-resistance (over 120 °C).
- Precautions in high humidity circumstance: This air conditioner has been tested according to the "KS Standard Conditions with Mist" and confirmed that there is not any default. However, if it is operated for a long time in high humid atmosphere (dew point temperature: more than 23 °C), water drops are liable to fall. In this case, add heat insulation material according to the following procedure:

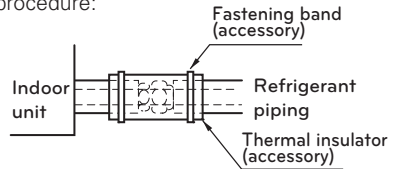

- Heat insulation material to be prepared... Adiabatic EPDM or NBR with thickness 10 to 20 mm.
- Stick glass wool on all air conditioners that are located in ceiling atmosphere.

Wiring Connection

- Open the control box cover and connect the Remote controller cord and Indoor power wires.
- Remove the control box cover for electrical connection between the indoor and outdoor unit. (Remove screws ①)
- Use the cord clumper to fix the cord.

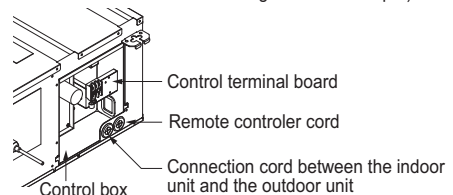
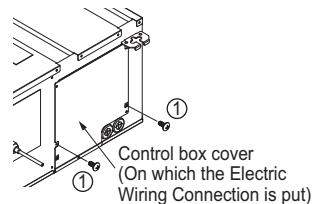

Ceiling Concealed Duct – Low Static, Mid Static

CAUTION

The connecting cable connected to the indoor and outdoor unit should be complied with the following specifications (This equipment shall be provided with a cord set complying with the national regulation).

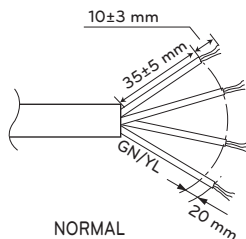

NORMAL
CROSS-SECTIONAL
AREA 0.75 mm²

If the supply cord is damaged, it must be replaced by a special cord or assembly available from the manufacturer of its service agent.

CAUTION

The Power cord connected to the unit should be selected according to the following specifications.

- The installation of a residual current device(RCD) having a rated residual operating current not exceeding 30 mA is advisable.

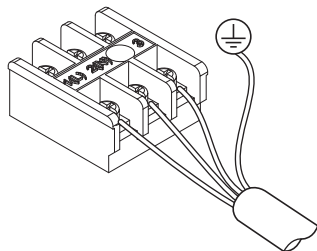
**Precautions when laying power wiring**

Use round pressure terminals for connections to the power terminal block.



When none are available, follow the instructions below.

- Do not connect wiring of different thicknesses to the power terminal block. (Slack in the power wiring may cause abnormal heat.)
- When connecting wiring which is the same thickness, do as shown in the figure below.

Connect same thickness wiring to both sides.

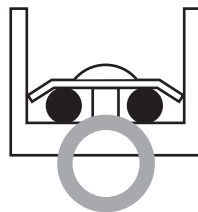

It is forbidden to connect two to one side.

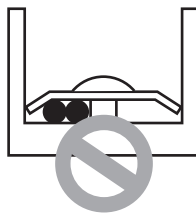

It is forbidden to connect wiring of different thicknesses.



- For wiring, use the designated power wire and connect firmly, then secure to prevent outside pressure being exerted on the terminal block.
- Use an appropriate screwdriver for tightening the terminal screws. A screwdriver with a small head will strip the head and make proper tightening impossible.
- Over-tightening the terminal screws may break them.

Flaring Work

Main cause for gas leakage is due to defect of flaring work. Carry out correct flaring work in the following procedure.

Cut the pipes and the cable

- 1 Use the piping kit accessory or the pipes purchased locally.
- 2 Measure the distance between the indoor and the outdoor unit.
- 3 Cut the pipes a little longer than measured distance.
- 4 Cut the cable 1.5 m longer than the pipe length.

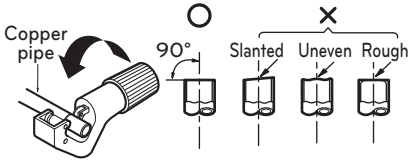

Burrs removal

1. Completely remove all burrs from the cut cross section of pipe/tube.
2. While removing burrs put the end of the copper tube/pipe in a downward direction while removing burrs location is also changed in order to avoid dropping burrs into the tubing.

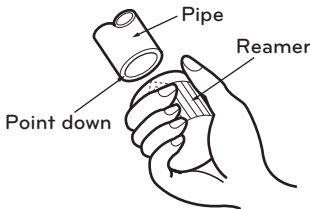

CAUTION

Copper in contact with refrigerants shall be oxygen-free or de-oxidized, for example Cu-DHP as specified in EN 12735-1 and EN 12735-2

Putting nut on

- Remove flare nuts attached to indoor and outdoor unit, then put them on pipe/tube having completed burr removal. (not possible to put them on after finishing flare work)

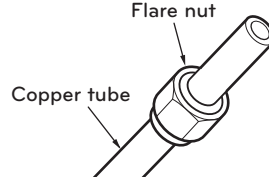

Flaring work

- 1 Firmly hold copper pipe in a bar with the dimension shown in below table table below.
- 2 Carry out flaring work with the flaring tool.

Pipe diameter Inch (mm)	A inch (mm)	
	Wing nut type	Clutch type
Ø 1/4 (Ø 6.35)	0.04~0.05 (1.1~1.3)	0~0.02 (0~0.5)
Ø 3/8 (Ø 9.52)	0.06~0.07 (1.5~1.7)	
Ø 1/2 (Ø 12.7)	0.06~0.07 (1.6~1.8)	
Ø 5/8 (Ø 15.88)	0.06~0.07 (1.6~1.8)	
Ø 3/4 (Ø 19.05)	0.07~0.08 (1.9~2.1)	

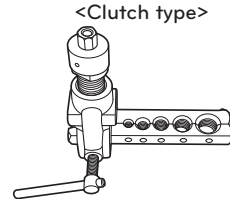
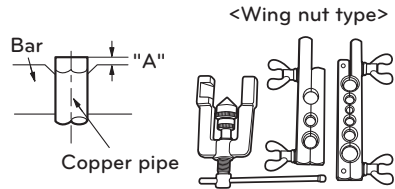

! CAUTION

- The installation of pipe-work shall be kept to a minimum
- Flared joint shall be restricted to use with annealed pipe only, and to pipe sizes not exceeding a diameter of 20 mm outside diameter.

Check

- 1 Compare the flared work with the figure by.
- 2 If a flared section is defective, cut it off and do flaring work again.

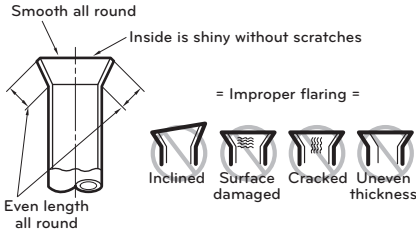

Connecting the installation pipe and drain hose to the indoor unit.

- 1 Align the center of the pipes and sufficiently tighten the flare nut by hand

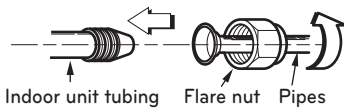

- 2 Tighten the flare nut with a wrench

Outside diameter		Torque
mm	inch	kgf·m
Ø 6.35	1/4	1.8~2.5
Ø 9.52	3/8	3.4~4.2
Ø 12.7	1/2	5.5~6.5
Ø 15.88	5/8	6.3~8.2
Ø 19.05	3/4	9.9~12.1

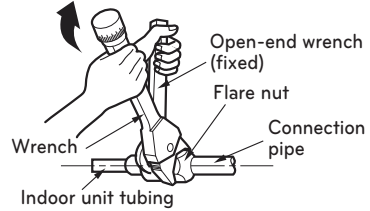

! CAUTION

- When mechanical connectors are reused indoors, sealing parts shall be renewed.
- When flared joints are reused indoors, the flare part shall be re-fabricated.

- 3 When needed to extend the drain hose of indoor unit, assembly the drain pipe as shown on the drawing

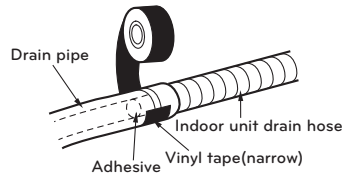

Wrap the insulation material around the connecting portion.

- 1 Overlap the connection pipe insulation material and the indoor unit pipe insulation material. Bind them together with vinyl tape so that there may be no gap.

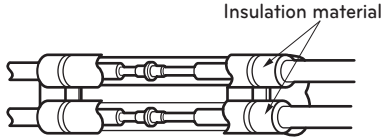

- 2 Set the tubing cutting line upward. Wrap the area which accommodates the rear piping housing section with vinyl tape.

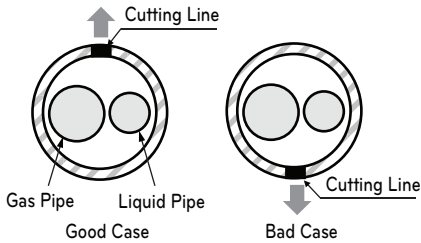

* Tubing cutting line have to be upward.

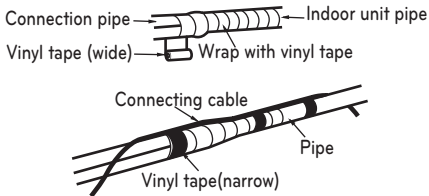

- 3 Bundle the piping and drain hose together by wrapping them with vinyl tape sufficient enough to cover where they fit into the rear piping housing section.

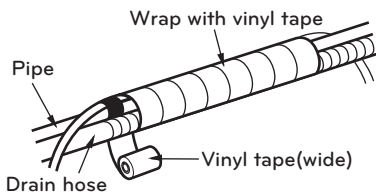

REMOTE CONTROLLER INSTALLATION

Please fix tightly using provided screw after placing remote controller setup board on the place where you like to setup.

- Please set it up not to bend because poor setup could take place if setup board bends. Please set up remote controller board fit to the reclamation box if there is a reclamation box.
- Install the product so as not to make a gap with the wall side and to prevent shaking after the installation.

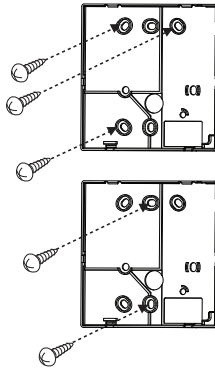

Can set up Wired remote controller cable into three directions.

- Setup direction: the surface of wall reclamation, upper, right
- If setting up remote controller cable into upper and right side, please set up after removing remote controller cable guide groove.
- * Remove guide groove with long nose.

- ① Reclamation to the surface of the wall
- ② Upper part guide groove
- ③ Right part guide groove

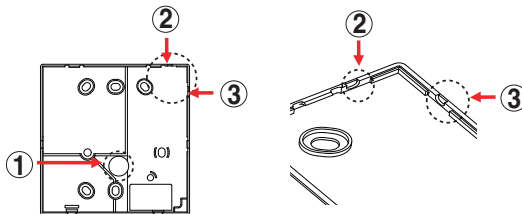

<Wire guide grooves>

Please fix remote controller upper part into the setup board attached to the surface of the wall, as the picture below, and then, connect with setup board by pressing lower part.

- Please connect not to make a gap at the remote controller and setup board's upper and lower, right and left part.
- Before assembly with the installation board, arrange the Cable not to interfere with circuit parts.

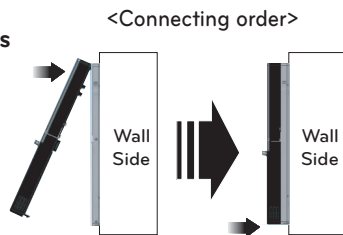

When separating remote controller from setup board, as the picture below, after inserting into the lower separating hole using screw driver and then, spinning clockwise, remote controller is separated.

- There are two separating holes. Please individually separate one at a time.
- Please be careful not to damage the inside components when separating.

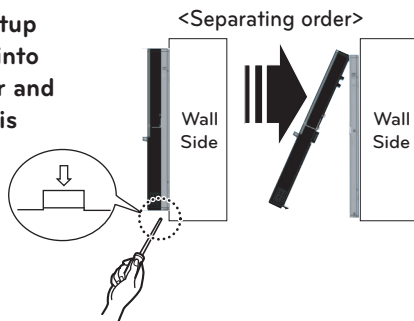

Please connect indoor unit and remote controller using connection cable.

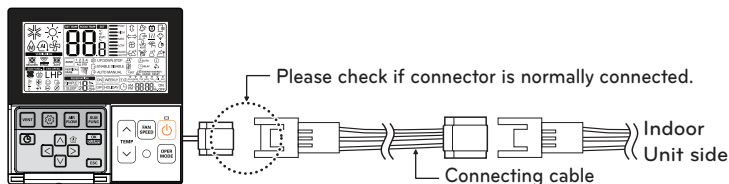

Please use extension cable if the distance between wired remote controller and indoor unit is more than 10 m.

⚠ CAUTION

When installing the wired remote controller, do not bury it in the wall. (It can cause damage in the temperature sensor.)

Do not install the cable to be 50 m or above. (It can cause communication error.)

- When installing the extension cable, check the connecting direction of the connector of the remote controller side and the product side for correct installation.
- If you install the extension cable in the opposite direction, the connector will not be connected.
- Specification of extension cable: 2547 1007 22# 2 core 3 shield 5 or above.

Wired remote controller installation

Since the room temperature sensor is in the remote controller, the remote controller box should be installed in a place away from direct sunlight, high humidity and direct supply of cold air to maintain proper space temperature. Install the remote controller about 5 ft(1.5 m) above the floor in an area with good air circulation at an average temperature.

Do not install the remote controller where it can be affected by:

- Drafts, or dead spots behind doors and in corners.
- Hot or cold air from ducts.
- Radiant heat from sun or appliances.
- Concealed pipes and chimneys.
- Uncontrolled areas such as an outside wall behind the remote controller.
- This remote controller is equipped with a seven segment LED display. For proper display of the remote controller LED's, the remote controller should be installed properly as shown in Fig.1. (The standard height is 1.2~1.5 m from floor level.)

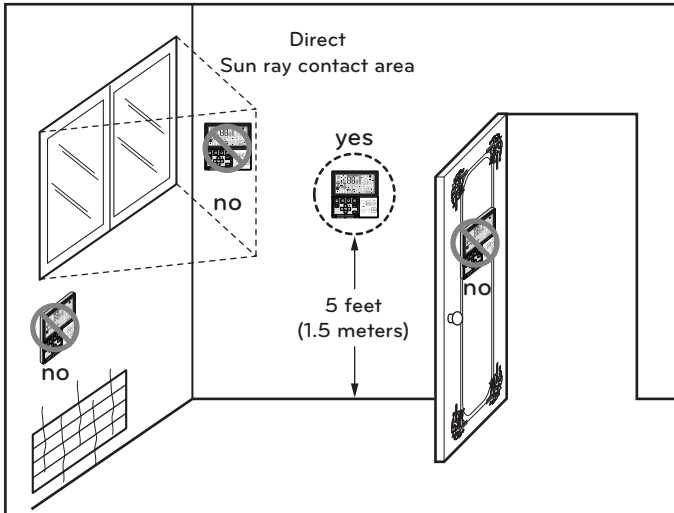



OPTIONAL OPERATION

Installer Setting - Test Run Mode

After installing the product, you must run a Test Run mode.

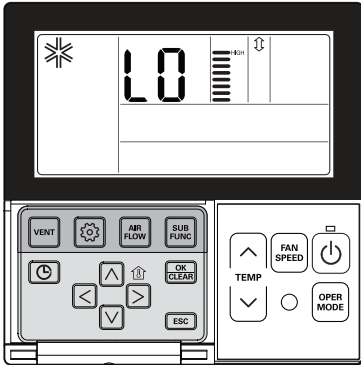
For details related to this operation, refer to the product manual.



- If pressing  button long for 3 seconds, it enters into remote controller setter setup mode.

 - If pressing once shortly, it enters into user setup mode. Please press more than 3 seconds for sure.
 - Please cancel the right and left of wind direction for RAC product.

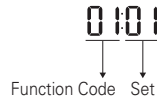

- Setup figure '01' blinks at the lower part of indication window.

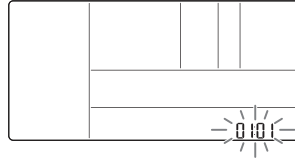

- Press  button to start.

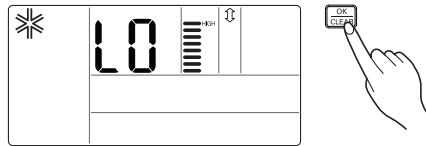



- During the test run, pressing the below button will exit the test run.

 - Select operation, temperature up/down, wind flow control, wind direction, start/stop button.

Installer Setting - Setting Address of Central Control

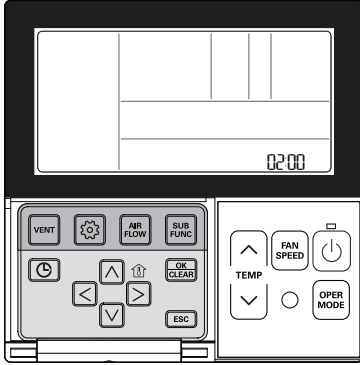
It's the function to use for connecting central control.
Please refer to central controller manual for the details



- 1** If pressing  button long for 3 seconds, it enters into remote controller setter setup mode.
- If pressing once shortly, it enters into user setup mode. Please press more than 3 seconds for sure.
- 

- 2** If entering into address setup mode by using  button, it indicates as picture below.

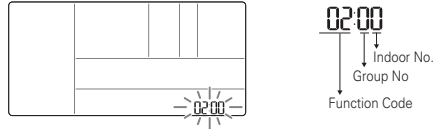

- 3** Set Group No. by pressing button.(0~F)

02:F0

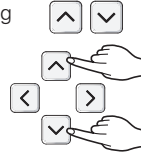

- 4** Move to Indoor No. setting option by pressing   button.

02:F0

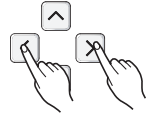

- 5** Set Indoor No. by pressing button.

02:F5

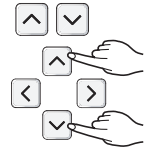

- 6** Press  button to save.

02:F5





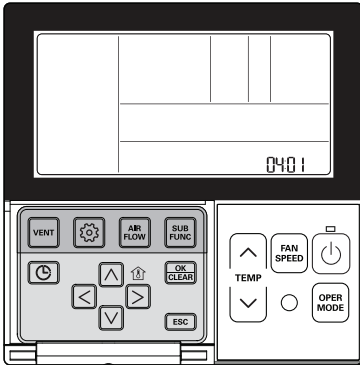

- 7** Pressing  button will exit settings mode.
* After setup, it automatically gets out of setup mode if there is no button input for 25 seconds.
* When exiting without pressing set button, the manipulated value is not reflected.



Installer Setting - Thermistor



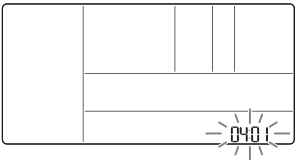

- 1** If pressing  button long for 3 seconds, it enters into remote controller setter setup mode.
 - If pressing once shortly, it enters into user setup mode. Please press more than 3 seconds for sure.

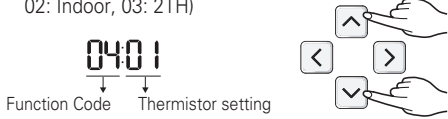
- 2** If moving to room temperature perception sensor selection menu by pressing  button, it indicates as picture below.

- 3** Set Thermistor value by pressing   button. (01: Remote Controller, 02: Indoor, 03: 2TH)

- 4** Press  button to save.

- 5** Pressing  button will exit settings mode.
 * After setup, it automatically gets out of setup mode if there is no button input for 25 seconds.
 * When exiting without pressing set button, the manipulated value is not reflected.

<Thermistor Table>



Temperature sensor selection		Function	
01	Remote controller	Operation in remote controller temperature sensor	
02	Indoor unit	Operation in indoor unit temperature sensor	
03	2TH	Cooling	Operation of higher temperature by comparing indoor unit's and wired remote controller's temperature. (There are products that operate at a lower temperature.)
		Heating	Operation of lower temperature by comparing indoor unit's and wired remote controller's temperature.

* The function of 2TH has different operation characteristics according to the product.

Installer Setting - Ceiling Height Selection

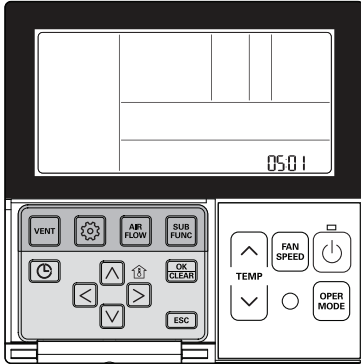

This function is to adjust FAN Airflow rate according to ceilingheight (only cassette model)

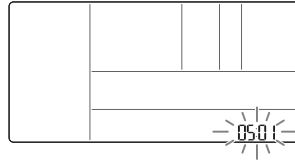

- 1 If pressing  button long for 3 seconds, it enters into remote controller setter setup mode.
- If pressing once shortly, it enters into user setup mode. Please press more than 3 seconds for sure. 

- 2 If moving to ceiling height selection menu by pressing  button, it indicates as picture below.



- 3 Select ceiling height value by pressing   button. (01:Low, 02:Standard, 03:High, 04Very high)

Function Code Thermistor setting

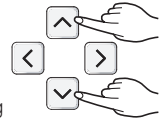

- 4 Press  button to save. 



- 5 Pressing  button will exit settings mode.
* After setup, it automatically gets out of setup mode if there is no button input for 25 seconds.
* When exiting without pressing set button, the manipulated value is not reflected.

<Ceiling Height Selection Table>

Ceiling Height Level	Description
01 Low	Decrease the indoor airflow rate 1 step from standard level
02 Standard	Set the indoor airflow rate as standard level
03 High	Increase indoor airflow rate 1 step from standard level
04 Super high	Increase indoor airflow rate 2 steps from standard level

* Ceiling height setting is available only for some products.

* Ceiling height of 'Super high' function may not exist depending on the indoor unit.

* Refer to the product manual for more details.

Installer Setting - Group Setting

It is a function for settings in group control, or 2-remote controller control.

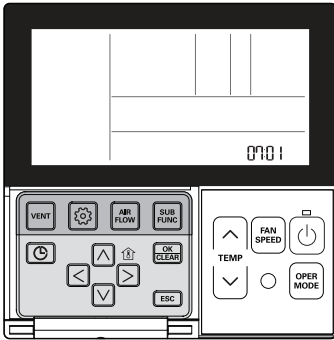



1 If pressing  button long for 3 seconds, it enters into remote controller setter setup mode.
 - If pressing once shortly, it enters into user setup mode. Please press more than 3 seconds for sure.

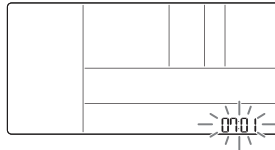

2 If pressing  button repeatedly, it moves to master/slave selection menu as picture below.



3 Select Master/ Slave by pressing   button.
 (00: Slave, 01: Master)

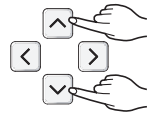

4 Press  button to save.

0701



5 Pressing  button will exit settings mode.
 * After setup, it automatically gets out of setup mode if there is no button input for 25 seconds.
 * When exiting without pressing set button, the manipulated value is not reflected.

Remote controller	Function
Master	Indoor unit operates based on master remote controller at group control. (Master is set when delivering from the warehouse.)
Slave	Setup all remote controllers except one master remote controller to slave at group control

* Refer to the 'group control' part for details

- When controlling in groups, basic operation settings, airflow strength weak/medium/strong, lock setting of the remote controller, time settings, and other functions may be restricted.

Installer Setting - Dry Contact Mode Setting

Dry contact function is the function that is possible to use only when dry contact equipment is separately purchased/setup.

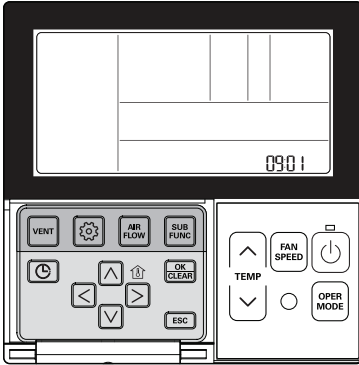

- 1** If pressing  button long for 3 seconds, it enters to remote controller setter setup mode.
- If pressing once shortly, it enters into user setup mode. Please press more than 3 seconds for sure.



- 2** If pressing  button repeatedly, it moves to remote controller dry contact mode setup menu as picture below.

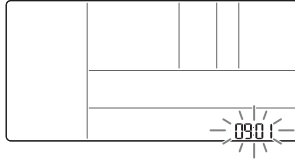

- 3** Select Dry contact setting by pressing  button.
(00 : Automatic, 01 : manual)



- 4** Press  button to save.

0901



- 5** Pressing  button will exit settings mode.
* After setup, it automatically gets out of setup mode if there is no button input for 25 seconds.
* When exiting without pressing set button, the manipulated value is not reflected.

What is Dry Contact?



Like hotel card key and body perception sensor, it is the signal of the point of contact when using air-conditioner by interlocking.

- Please refer to dry contact manual for more details.

Installer Setting - Celsius / Fahrenheit Switching

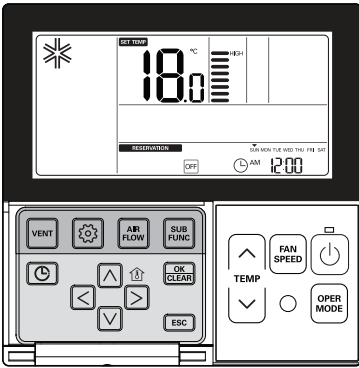
This function is used for switching the display between Celsius and Fahrenheit.
(Optimized only for U.S.A)



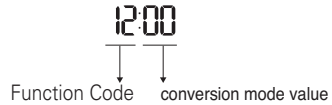

- 1 If pressing  button long for 3 seconds, it enters into remote controller setter setup mode.
- If pressing once shortly, it enters into user setup mode.
Please press more than 3 seconds for sure. 

- 2 Repeat pressing  button to select Function code 12.





Ex) Fahrengzeit Setting

- 3 Select Temperature unit mode by pressing   button.
(00: Celsius, 01: Fahrenheit)

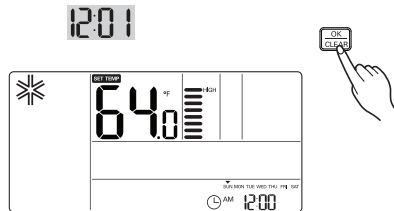

- 4 Press  button to save or release.





- 5 Press  button to exit or system will automatically exit after 25 seconds without any input. 

* Whenever press   button in Fahrenheit mode, the temperature will increase/drop 2 degrees.

Installer Setting - Optional Function Setting

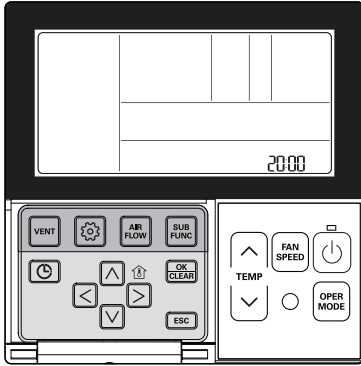
Setting feature for indoor unit when air cleaning / heater / humidifier / Up/down grill / Ventilation KIT / Auxiliary Heater is newly installed, or installed unit is removed.





- 1** If pressing  button long for 3 seconds, it enters into remote controller setter setup mode.
- If pressing once shortly, it enters into user setup mode. Please press more than 3 seconds for sure.
- 

- 2** If pressing  button repeatedly, it moves to the selected option function code as picture below.

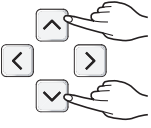

Function	Code
Plasma purification	20
Electric heater	21
Dehumidifier	22
Elevation grill	23
Ventilation kit	24
Auxiliary heater	25

- 3** Select existing condition of each mode by pressing   button.
(00: not installed,
01 : installed)
- 

20:00

Function Code Existing condition

- 4** Press  button to save.
- 



- 5** Pressing  button will exit settings mode.
* After setup, it automatically gets out of setup mode if there is no button input for 25 seconds.
* When exiting without pressing set button, the manipulated value is not reflected.

Installer Setting - Remote controller Mode Lock

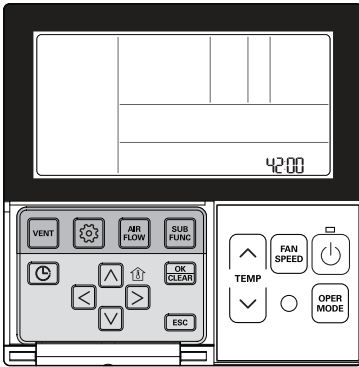
This function is used to limit 'operation-mode' selection setting.



- 1** Press and hold  button for more than 3 seconds to enter the installer settings mode. 

- 2** Move to the installer code number 42 in the menu using  button. 

- 3** Select the remote control master/slave using   button.

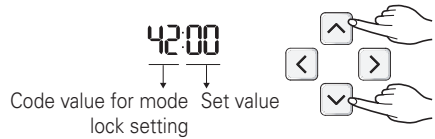

code	Description
42:00	Doesn't limit operation mode setting.
42:01	User can setting to cooling mode only.
42:02	User can setting to heating mode only.

- 4** Press  button to save the setting.

- 5** Press  button to exit.

* It can limit only wired remote controller button. other controllers can change operation mode. (for example wireless remote controller and central controller)

HOW TO SET E.S.P.?

Installer Setting - E.S.P.

This is the function that decides the strength of the wind for each wind level and because this function is to make the installation easier.

- If you set ESP incorrectly, the air conditioner may malfunction.
- This setting must be carried out by a certificated-technician.

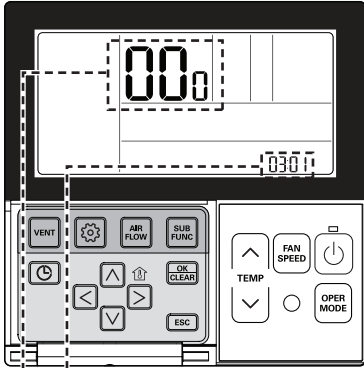

Function code,
ESP code

ESP value

- 1 If pressing button long for 3 seconds, it enters into remote controller setter setup mode.
- If pressing once shortly, it enters into user setup mode. Please press more than 3 seconds for sure.



- 2 If entering into ESP setup mode by using button, it indicates as the picture below.

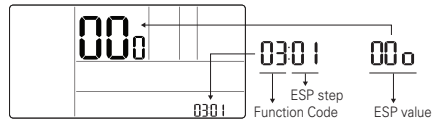

- 3 Select ESP fan step by pressing button. (01: very low, 02: low, 03: medium, 04: high, 05: power)

0301

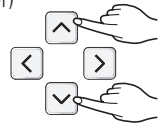

- 4 Move to ESP value setting by pressing button.
(It is 000 when delivering from the warehouse.)

0301 000

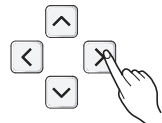

- 5 Press button to setup ESP value.

(It is possible to setup ESP value from 1 to 255, and 1 is the smallest and 255 is the biggest.)

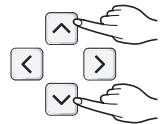

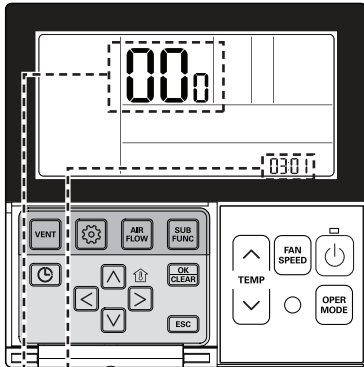

- When setting ESP value on the product without very weak wind or power wind function, it may not work.



Function code,
ESP code

ESP value

6 Select ESP fan step again by using   button and setup ESP value, as No. 4 and 5, that corresponds each wind flow

7 Press  button to save.



8 Press  button to exit.

- * After setup, it automatically gets out of setup mode if there is no button input for 25 seconds.
- * When exiting without pressing set button, the manipulated value is not reflected.

- Please be careful not to change the ESP value for each fan step.
- It does not work to setup ESP value for very low/power step for some products.
- ESP value is available for specific range belongs to the product.

Installer Setting - Static Pressure Step Setting

This function is applied to only duct type. Setting this in other cases will cause malfunction.

This function is only available on some products.

This is the function that static pressure of the product is divided in 11 steps for setting.

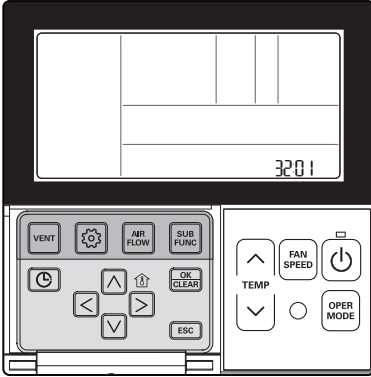

1 When pressing the button and button simultaneously for more than 3 seconds, the system will be entered into the installer setting mode.

- After entering into the installer setting mode, select the static pressure step setting code value by pressing the button.

* Static pressure step setting code value : 32

2 Select the desired setting value with the temperature up() , down() button.

32.0

Function Code Existing condition

00: use static pressure (code 06) set value
01~ 11: static pressure step (code 32) set value

3 When pressing button, currently established static pressure value will be set up.

4 When pressing the button and button simultaneously for more than 3 seconds after the setting has been completed, the setting mode will be released.
- If there isn't any button input for more than 25 seconds, the installer setting mode will also be released.

- Static Pressure (Code 06) setting will not be used if Static Pressure Step (Code 32) setting is being used.

- For the static pressure value for each step, refer to the next page Table. 1

Ceiling Concealed Duct – Low static

Table 1

Capacity(kBtu/h)	Step	CMM	Static Pressure [mmAq (Pa)]					
			0(0)	1(10)	2(20)	3(29)	4(39)	5(49)
			Setting Value					
			32:01	32:02	32:03	32:04	32:05	32:06
9	LOW	5.5	69	76	83	91	101	111
	MID	7	81	87	94	101	109	117
	HIGH	9	97	103	108	117	124	131

Capacity(kBtu/h)	Step	CMM	Static Pressure [mmAq (Pa)]					
			0(0)	1(10)	2(20)	3(29)	4(39)	5(49)
			Setting Value					
			32:01	32:02	32:03	32:04	32:05	32:06
12	LOW	7	78	82	87	93	100	107
	MID	8.5	87	91	94	100	108	116
	HIGH	10	96	100	103	109	117	125

Capacity(kBtu/h)	Step	CMM	Static Pressure [mmAq (Pa)]					
			0(0)	1(10)	2(20)	3(29)	4(39)	5(49)
			Setting Value					
			32:01	32:02	32:03	32:04	32:05	32:06
18	LOW	10	96	100	103	109	117	125
	MID	12.5	109	113	117	123	130	137
	HIGH	15	120	124	129	134	141	147

Capacity(kBtu/h)	Step	CMM	Static Pressure [mmAq (Pa)]					
			0(0)	1(10)	2(20)	3(29)	4(39)	5(49)
			Setting Value					
			32:01	32:02	32:03	32:04	32:05	32:06
24	LOW	12	89	95	102	106	120	130
	MID	16	102	108	115	125	131	139
	HIGH	20	125	131	136	141	144	147

! NOTE

1. The above table shows the correlation between the air rates and E.S.P.
2. Be sure to set the value referring table 1. Unexpected set value will cause mal-function.
3. Table 1 is based at 230 V. According to the fluctuation of voltage, air flow rate varies.

Ceiling Concealed Duct – Mid static

Table 2

Capacity(kBtu/h)	Step	CMM	Static Pressure[mmAq(Pa)]										
			2(20)	2.5(25)	3(29)	4(39)	6(59)	8(78)	10(98)	12(118)	13(127)	14(137)	15(147)
			Setting Value										
			32:01	32:02	32:03	32:04	32:05	32:06	32:07	32:08	32:09	32:10	32:11
18	LOW	13	73	74	77	88	93	103	111	117	120	125	128
	MID	14.5	76	77	85	91	97	107	114	121	125	128	131
	HIGH	16.5	85	87	90	94	103	110	118	125	128	131	134
24	LOW	14.5	76	77	85	89	97	106	114	121	124	127	132
	MID	16.5	85	87	90	94	103	111	118	125	128	131	136
	HIGH	18	90	92	95	99	108	115	122	129	132	135	138

Capacity(kBtu/h)	Step	CMM	Static Pressure[mmAq(Pa)]										
			2.5(25)	4(39)	5(49)	6(59)	7(69)	8(78)	9(88)	10(98)	11(108)	13(127)	15(147)
			Setting Value										
			32:01	32:02	32:03	32:04	32:05	32:06	32:07	32:08	32:09	32:10	32:11
30	LOW	18	96	102	107	110	114	118	122	125	127	130	132
	MID	20	102	110	114	118	121	125	127	130	133	134	136
	HIGH	22	110	117	121	124	127	130	133	136	137	138	140

Capacity(kBtu/h)	Step	CMM	Static Pressure[mmAq(Pa)]										
			4(39)	5(49)	6(59)	7(69)	8(78)	9(88)	10(98)	11(108)	12(118)	13(127)	15(147)
			Setting Value										
			32:01	32:02	32:03	32:04	32:05	32:06	32:07	32:08	32:09	32:10	32:11
36	LOW	24	88	91	95	100	101	108	113	115	118	121	128
	MID	28	93	97	101	105	108	115	118	120	124	127	134
	HIGH	32	101	105	109	112	115	119	123	126	128	133	137

Capacity(kBtu/h)	Step	CMM	Static Pressure[mmAq(Pa)]										
			5(49)	6(59)	7(69)	8(78)	9(88)	10(98)	11(108)	12(118)	13(127)	14(137)	15(147)
			Setting Value										
			32:01	32:02	32:03	32:04	32:05	32:06	32:07	32:08	32:09	32:10	32:11
42	LOW	28	100	103	106	110	114	118	121	125	128	133	136
	MID	33	108	111	114	118	122	125	128	131	134	138	141
	HIGH	38	117	120	124	127	130	133	135	138	141	144	147

Capacity(kBtu/h)	Step	CMM	Static Pressure[mmAq(Pa)]										
			4(39)	5(49)	6(59)	7(69)	8(78)	9(88)	10(98)	11(108)	12(118)	13(127)	15(147)
			Setting Value										
			32:01	32:02	32:03	32:04	32:05	32:06	32:07	32:08	32:09	32:10	32:11
48	LOW	28	74	76	79	82	89	92	94	96	99	102	107
	MID	34	78	82	84	89	94	96	98	101	104	106	112
	HIGH	40	83	89	92	94	98	100	102	105	108	110	116

Capacity(kBtu/h)	Step	CMM	Static Pressure[mmAq(Pa)]										
			4(39)	5(49)	6(59)	7(69)	8(78)	9(88)	10(98)	11(108)	12(118)	13(127)	15(147)
			Setting Value										
			32:01	32:02	32:03	32:04	32:05	32:06	32:07	32:08	32:09	32:10	32:11
60	LOW	40	82	89	92	94	98	100	102	105	108	110	113
	MID	45	90	92	96	98	102	104	106	109	112	114	117
	HIGH	50	94	97	100	104	107	109	112	115	117	119	121

! NOTE

1. Be sure to set the value referring table 2. Unexpected set value will cause mal-function.
2. Table 2 is based at 230 V. According to the fluctuation of voltage, air flow rate varies.
3. Factory Set(External Static Pressure) each Model

Capacity(kBtu/h)	Factory set (E.S.P.) mmAq(Pa)
18	6(59)
24	
30	
36	
42	
48	
60	

* If it is zero static pressure, please set value below Maximum value.

Capacity(kBtu/h)	Maximum value
18	115
24	
30	
36	120
42	
48	98
60	

Installer Setting – Auto ESP

This function automatically sets the rotation speed of the fans corresponding to each step of rated airflow for easy installation.

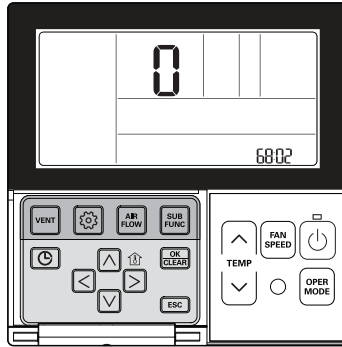



If  button is pressed so long for over 3 seconds, it enters to the installer setting mode.

- If it is pressed shortly for one time, it enters to the user setting mode.

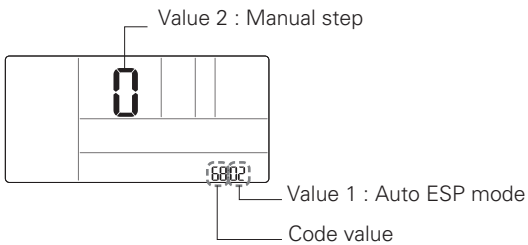

Be sure to press it for so long over 3 seconds.

If  button is pressed repeatedly, it is moved to Auto ESP setting menu as the picture below.



Press   button and select the setting value per each function.

42 HOW TO SET E.S.P?

- * The voltage can be set by setting the Auto ESP Mode to 'Manual (02)'. Move to the manual step settings using   button.
- * While 'Auto ESP' is being set, the display on the wired remote control changes as shown below, and the wired remote control cannot be operated.
- * Once the set-up is complete, you can enter installer setup (68) to check whether the set-up has succeeded or failed. (03: Success, 04: Failure)

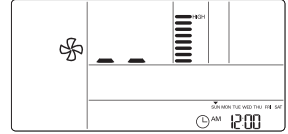
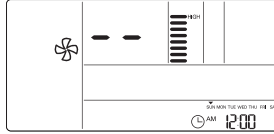
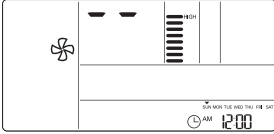

Value 1 (Auto ESP mode)	Value 2 (Manual Step)	Description (Voltage setting)
00 (Not use)	-	-
01 (Auto)	-	-
02 (Manual)	0	190 V
	1	200 V
	2	210 V
	3	220 V
	4	230 V
	5	240 V
	6	250 V
	7	260 V
8	270 V	
03	-	Cannot be set, only monitoring is possible. If the value1 is 03, setting is successful.
04	-	Cannot be set, only monitoring is possible. If the value1 is 04, setting has failed.

After selecting the corresponding function, press  button to complete the setting.

Press the  button to exit the setting mode.

- * If there would be no button input for about 25 seconds after setting, it exits from the setting mode automatically.
- * If it is exited without pressing  button, the handled value is not reflected.

! NOTE

If this function is incorrectly set especially, in case of mismatching the voltage, the air conditioner may malfunction.

This function must be set by the installation specialist that holds an installation license. (please check the product type)

! NOTE

- If the heat exchanger is not dry, please set the device to operate in air circulation mode for 15 minutes.
- The air filter must be properly attached to the suction side of the product.
- Adjust the dampers so that each air inlet and outlet exhaust the required air.
- Please do not use the set auto air flow function when using various booster fans (outdoor air treatment device or ERV through ducts).
- Please reinitiate the set auto air flow function if the duct shape has changed since its initial installation.
- When setting the voltage manually, the set air flow will differ from the actual air flow if the set voltage is different from the actual voltage.
- When setting voltage manually, measure the actual voltage and select the set voltage on the remote control.
- Failure to follow the above method may cause the actual air flow to differ from the rated air flow.

SELF-DIAGNOSIS FUNCTION

Indoor Unit Error

Ex) Error 03 (Remote controller error)

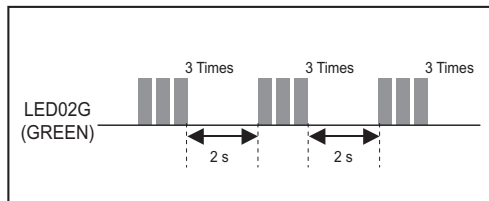

(*C : Compact Inverter Outdoor)

L2 9K L2 12K M1 18K	L2 18K M1 18K M1 24K (*C) M1 30K (*C)	M1 24K M1 30K L3 24K	M2 36K M2 42K M3 38K M3 60K

Error Code	Description	LED 1 (Red)	LED 2 (Green)	Indoor status
01	Indoor Room sensor error	0	1 time ●	OFF
02	Indoor in-pipe sensor error	0	2 times ●	OFF
03	Remote controller error	0	3 times ●	OFF
04	Drain pump error	0	4 times ●	OFF
05	Communication error indoor and outdoor	0	5 times ●	OFF
06	Indoor out-pipe sensor error	0	6 times ●	OFF
09	EEPROM error (indoor)	0	9 times ●	OFF
10	BLDC motor fan lock (indoor)	1 time ●	0	OFF

* Because remote controller turn off when occur ERROR in simultaneous operation system, it should check LED blinks of outdoor in order to confirm error code.

* Repeatedly after LED1 is turned on and off as the Error code number of tens digit, LED2 is turned on and off as the Error code number of single-digit.

DIP SWITCH SETTING

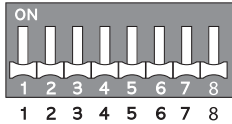

	Function	Description	Setting Off	Setting On	Default
SW3	Group Control	Selection of Master or Slave	Master	Slave	Off
SW4	Dry Contact Mode	Selection of Dry Contact Mode	Wired/Wireless remote controller Selection of Manual or Auto operation Mode	Auto	Off
SW5	Installation	Fan continuous operation	Continuous operation Removal	Working	Off



Manufacturer :

LG Electronics Inc.

84, Wanam-ro, Seongsan-gu, Changwon-si, Gyeongsangnam-do, KOREA

Eco design requirement

- The information for Eco design is available on the following free access website.
<https://www.lg.com/global/support/cedoc/cedoc>