



# INSTALLATION MANUAL

# AIR CONDITIONER

Please read this installation manual completely before installing the product.  
Installation work must be performed in accordance with the national wiring standards by authorized personnel only.  
Please retain this installation manual for future reference after reading it thoroughly.

Ceiling Concealed Duct  
Original instruction  
For commercial use



MFL67142716  
Rev.08\_111925



[www.lg.com](http://www.lg.com)

Copyright © 2017 - 2025 LG Electronics Inc. All Rights Reserved.

РУССКИЙ ЯЗЫК

ENGLISH

УКРАЇНСЬКА

ITALIANO

ҚАЗАҚ ТІЛІ

ESPAÑOL

БЕЛАРУСКАЯ МОВА

FRANÇAIS

ЎЗБЕК ТИЛИ

DEUTSCH

EMHNIKA

ČEŠTINA

NEDERLANDS

POLSKI

LMBA ROMÂNĂ

# TABLE OF CONTENTS

## 3 FEATURES

---

## 4 SAFETY INSTRUCTIONS

---

## 10 INSTALLATION

---

- 10 Selection of the best location (Low Static)
- 11 Selection of the best location (Mid / High Static)
- 13 Ceiling dimension and hanging bolt location (Low Static)
- 14 Ceiling dimension and hanging bolt location (Mid Static)
- 15 Ceiling dimension and hanging bolt location (High Static)
- 16 Indoor Unit Installation
- 16 Wiring Connection
- 19 Checking the Drainage
- 20 Drain Piping
- 22 DIP Switch Setting
- 23 Group Control Setting
- 28 Model Designation
- 28 Airborne Noise Emission
- 28 Limiting concentration

## 29 HOW TO SET E.S.P?





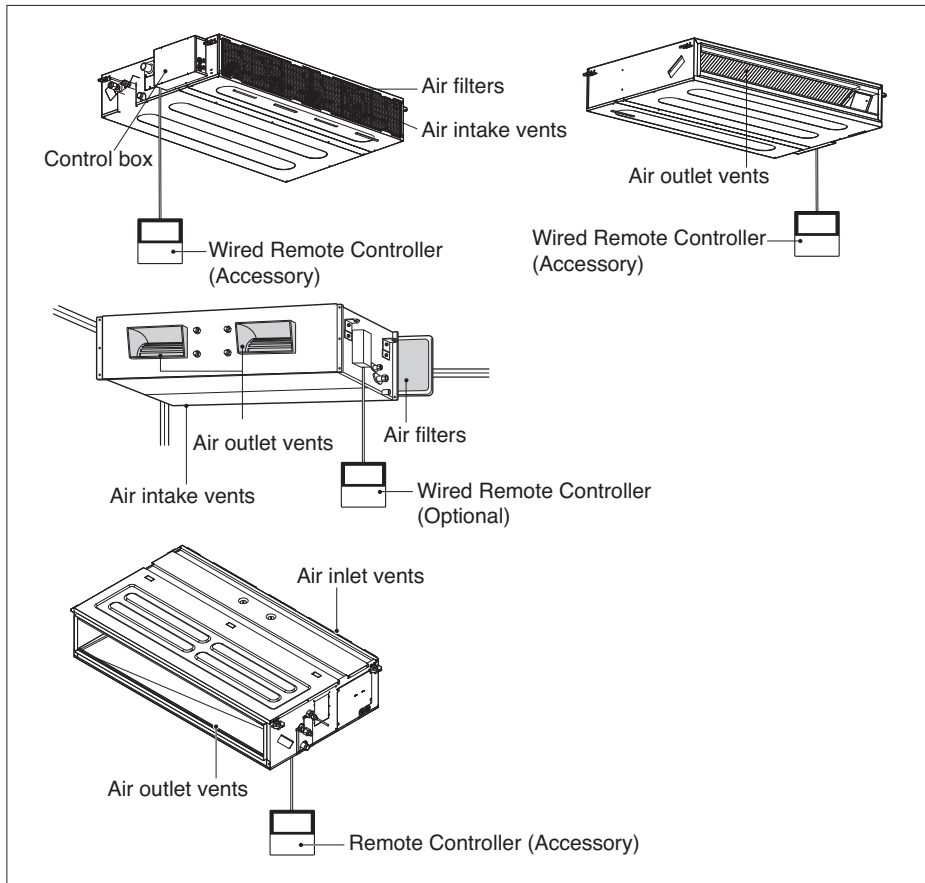

---

- 34 How to Set Auto ESP (Air conditioner)

# Features







## Installation Tool

Name	Drain hose	Clamp metal	Washer for hanging bracket	Clamp (Tie Wrap)	Insulation for fitting	(Other)
Quantity	1 EA	2 EA	8 EA	4 EA	1 SET	• Manual
Shape					 for gas pipe  for liquid pipe	

## Safety instructions

The following symbols are displayed on indoor and outdoor units.

	Read the precautions in this manual carefully before operating the unit.		This appliance is filled with flammable refrigerant. (for R32)
	This symbol indicates that the Operation Manual should be read carefully.		This symbol indicates that a service personnel should be handling this equipment with reference to the Installation Manual.

The following safety guidelines are intended to prevent unforeseen risks or damage from unsafe or incorrect operation of the appliance. The guidelines are separated into 'WARNING' and 'CAUTION' as described below.

**⚠** This symbol is displayed to indicate matters and operations that can cause risk. Read the part with this symbol carefully and follow the instructions in order to avoid risk.

### **⚠ WARNING**

This indicates that the failure to follow the instructions can cause serious injury or death.

### **⚠ CAUTION**

This indicates that the failure to follow the instructions can cause the minor injury or damage to the product.

## **⚠ WARNING**

### Installation

- Compliance with national gas regulations shall be observed.
- Do not use a defective or underrated circuit breaker. Use this appliance on a dedicated circuit.
  - There is risk of fire or electric shock.
- For electrical work, contact the dealer, seller, a qualified electrician, or an Authorized Service Center.
  - Do not disassemble or repair the product. There is risk of fire or electric shock.
- Always ground the product.
  - There is risk of fire or electric shock.
- Install the panel and the cover of control box securely.
  - There is risk of fire or electric shock.

- Always install a dedicated circuit and breaker.
  - Improper wiring or installation may cause fire or electric shock.
- Use the correctly rated breaker or fuse.
  - There is risk of fire or electric shock.
- Do not modify or extend the power cable.
  - There is risk of fire or electric shock.
- Do not install, remove, or re-install the unit by yourself (customer).
  - There is risk of fire, electric shock, explosion, or injury.
- Be cautious when unpacking and installing the product.
  - Sharp edges could cause injury. Be especially careful of the case edges and the fins on the condenser and evaporator.
- For installation, always contact the dealer or an Authorized Service Center.
  - There is risk of fire, electric shock, explosion, or injury.
- Do not install the product on a defective installation stand.
  - It may cause injury, accident, or damage to the product.
- Be sure the installation area does not deteriorate with age.
  - If the base collapses, the air conditioner could fall with it, causing property damage, product failure, and personal injury.
- Do not turn on the breaker or power under condition that front panel, cabinet, top cover, control box cover are removed or opened.
  - Otherwise, it may cause fire, electric shock, explosion or death.
- Use a vacuum pump or Inert (nitrogen) gas when doing leakage test or air purge. Do not compress air or Oxygen and Do not use Flammable gases. Otherwise, it may cause fire or explosion.
  - There is the risk of death, injury, fire or explosion.
- Have all electric work done by a licensed electrician according to "Electric Facility Engineering Standard" and "Interior Wire Regulations" and the instructions given in this manual and always use a special circuit.
  - If the power source capacity is inadequate or electric work is performed improperly, electric shock or fire may result.
- Always install a dedicated circuit and breaker.
  - Improper wiring or installation may cause fire or electric shock.
- The appliance shall be stored in a well-ventilated area where the room size corresponds to the room area as specified for operation. (for R32)
- Ducts connected to an appliance shall not contain an ignition source. (for R32)
- The appliance shall be stored in a room without continuously operating ignition sources (for example: open flames, an operating gas appliance or an operating electric heater.)
- Keep any required ventilation openings clear of obstruction.

- Mechanical connections shall be accessible for maintenance purposes.
- To prevent the mixing of different types of refrigerants, be sure to check the type of refrigerant used in the outdoor unit.

## **Operation**

- Do not let the air conditioner run for a long time when the humidity is very high and a door or a window is left open.
  - Moisture may condense and wet or damage furniture.
- Take care to ensure that power cable could not be pulled out or damaged during operation.
  - There is risk of fire or electric shock.
- Do not place anything on the power cable.
  - There is risk of fire or electric shock.
- Do not plug or unplug the power supply plug during operation.
  - There is risk of fire or electric shock.
- Do not touch(operate) the product with wet hands.
  - There is risk of fire or electrical shock.
- Do not place a heater or other appliances near the power cable.
  - There is risk of fire and electric shock.
- Do not allow water to run into electric parts.
  - There is risk of fire, failure of the product, or electric shock.
- Do not store or use flammable gas or combustibles near the product.
  - There is risk of fire or failure of product.
- Do not use the product in a tightly closed space for a long time.
  - Oxygen deficiency could occur.
- When flammable gas leaks, turn off the gas and open a window for ventilation before turn the product on.
  - Do not use the telephone or turn switches on or off. There is risk of explosion or fire.
- If strange sounds, smell or smoke comes from product. Turn the breaker off or disconnect the power supply cable.
  - There is risk of electric shock or fire.
- Stop operation and close the window in storm or hurricane.  
If possible, remove the product from the window before the hurricane arrives.
  - There is risk of property damage, failure of product, or electric shock.
- Do not open the inlet grill of the product during operation.  
(Do not touch the electrostatic filter, if the unit is so equipped.)
  - There is risk of physical injury, electric shock, or product failure.

- When the product is soaked (flooded or submerged), contact an Authorized Service Center.
  - There is risk of fire or electric shock.
- Be cautious that water could not enter the product.
  - There is risk of fire, electric shock, or product damage.
- Ventilate the product from time to time when operating it together with a stove, etc.
  - There is risk of fire or electric shock.
- Turn the main power off when cleaning or maintaining the product.
  - There is risk of electric shock.
- When the product is not be used for a long time, disconnect the power supply plug or turn off the breaker.
  - There is risk of product damage or failure, or unintended operation.
- Take care to ensure that nobody could step on or fall onto the outdoor unit.
  - This could result in personal injury and product damage.
- When mechanical connectors are reused indoors, sealing parts shall be renewed. (for R32)
- When flared joints are reused indoors, the flare part shall be re-fabricated. (for R32)
- Periodic ( more than once/year ) cleaning of the dust or salt particles stuck on the heat exchanger by using water.
- Do not use means to accelerate the defrosting process or to clean, other than those recommended by the manufacturer.
- Do not pierce or burn refrigerant cycle part.
- Be aware that refrigerants may not contain an odour.

---

**CAUTION**

---

## Installation

- Always check for gas (refrigerant) leakage after installation or repair of product.
  - Low refrigerant levels may cause failure of product.
- Install the drain hose to ensure that water is drained away properly.
  - A bad connection may cause water leakage.
- Keep level even when installing the product.
  - To avoid vibration or water leakage.
- Do not install the product where the noise or hot air from the outdoor unit could damage the neighborhoods.
  - It may cause a problem for your neighbors.
- Use two or more people to lift and transport the product.
  - Avoid personal injury.

- Do not install the product where it will be exposed to sea wind (salt spray) directly.
  - It may cause corrosion on the product. Corrosion, particularly on the condenser and evaporator fins, could cause product malfunction or inefficient operation.
- Any person who is involved with working on or breaking into a refrigerant circuit should hold a current valid certificate from an industry-accredited assessment authority, which authorises their competence to handle refrigerants safely in accordance with an industry recognised assessment specification. (for R32)
- The appliance shall be stored so as to prevent mechanical damage from occurring.
- Refrigerant tubing shall be protected or enclosed to avoid damage.
- Flexible refrigerant connectors (such as connecting lines between the indoor and outdoor unit) that may be displaced during normal operations shall be protected against mechanical damage.
- The installation of pipe-work shall be kept to a minimum.
- Pipe-work shall be protected from physical damage.
- A brazed, welded, or mechanical connection shall be made before opening the valves to permit refrigerant to flow between the refrigerating system parts.
- Dismantling the unit, treatment of the refrigerant oil and eventual parts should be done in accordance with local and national standards.
- Do not install the unit in potentially explosive atmospheres.

## **Operation**

- Do not expose the skin directly to cool air for long periods of time. (Don't sit in the draft.)
  - This could harm to your health.
- Do not use the product for special purposes, such as preserving foods, works of art, etc. It is a consumer air conditioner, not a precision refrigeration system.
  - There is risk of damage or loss of property.
- Do not block the inlet or outlet of air flow.
  - It may cause product failure.
- Use a soft cloth to clean. Do not use harsh detergents, solvents, etc.
  - There is risk of fire, electric shock, or damage to the plastic parts of the product.

- Do not touch the metal parts of the product when removing the air filter. They are very sharp!
  - There is risk of personal injury.
- Do not step on or put anything on the product. (outdoor units)
  - There is risk of personal injury and failure of product.
- Always insert the filter securely. Clean the filter every two weeks or more often if necessary.
  - A dirty filter reduces the efficiency of the air conditioner and could cause product malfunction or damage.
- Do not insert hands or other objects through the air inlet or outlet while the product is operated.
  - There are sharp and moving parts that could cause personal injury.
- Do not drink the water drained from the product.
  - It is not sanitary and could cause serious health issues.
- Use a firm stool or ladder when cleaning or maintaining the product.
  - Be careful and avoid personal injury.
- Replace the all batteries in the remote control with new ones of the same type. Do not mix old and new batteries or different types of batteries.
  - There is risk of fire or explosion.
- Do not recharge or disassemble the batteries. Do not dispose of batteries in a fire.
  - They may burn or explode.
- If the liquid from the batteries gets onto your skin or clothes, wash it well with clean water. Do not use the remote if the batteries have leaked.
  - The chemicals in batteries could cause burns or other health hazards.
- If you eat the liquid from the batteries, brush your teeth and see doctor. Do not use the remote if the batteries have leaked.
  - The chemicals in batteries could cause burns or other health hazards.
- Servicing shall only be performed as recommended by the equipment manufacturer. Maintenance and repair requiring the assistance of other skilled personnel shall be carried out under the supervision of the person competent in the use of flammable refrigerants. (for R32)
- Means for disconnection must be incorporated in the fixed wiring in accordance with the wiring rules.

# Installation

## Selection of the best location (Low Static)

### Indoor unit

Install the air conditioner in the location that satisfies the following conditions.

- The place shall easily bear a load exceeding four times the indoor unit's weight.
- The place shall be able to inspect the unit as the figure.
- The place where the unit shall be leveled.
- The place shall easily connect with the outdoor unit.
- The place where the unit is not affected by an electrical noise.
- The place where air circulation in the room will be good.
- There should not be any heat source or steam near the unit

Confirm the positional relationship between the unit and suspension bolts.

- Installation the ceiling opening to clean the filter or service under the product.

(Unit: mm)

Capacity (kBtu/h)	A	B
5/7/9	800	800
12/15/18	800	1 000
21/24	800	1 200

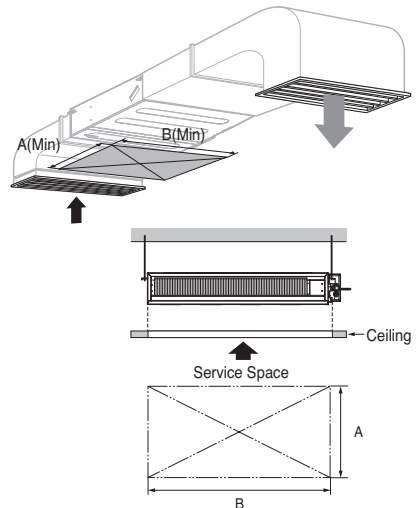
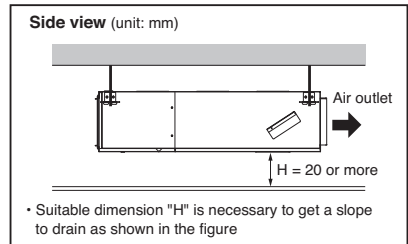
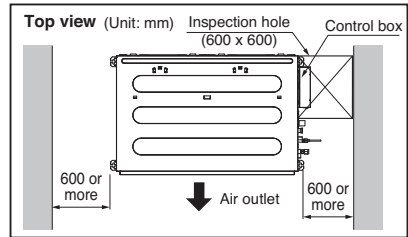

## Selection of the best location (Mid / High Static)

Install the air conditioner in the location that satisfies the following conditions.

- The place shall easily bear a load exceeding four times the indoor unit's weight.
- The place shall be able to inspect the unit as the figure.
- The place where the unit shall be leveled.
- The place shall allow easy water drainage.  
(Suitable dimension "H" is necessary to get a slope to drain as figure.)
- The place shall easily connect with the outdoor unit.
- The place where the unit is not affected by an electrical noise.
- The place where air circulation in the room will be good .
- There should not be any heat source or steam near the unit.

Mid Static

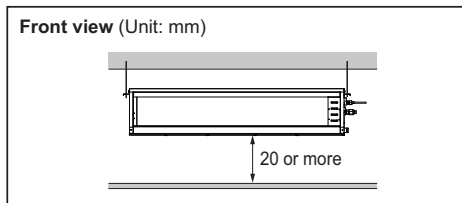
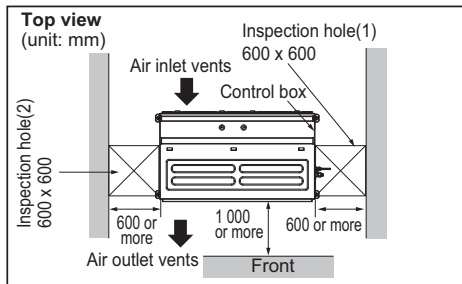

High Static

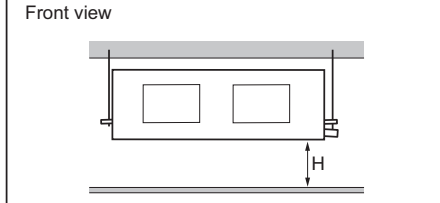
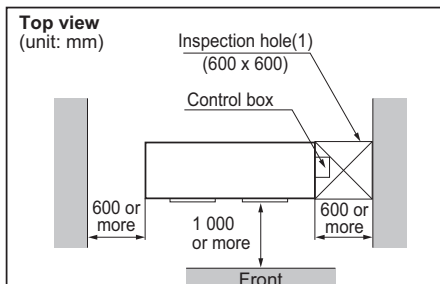

### **⚠ CAUTION**

In case that the unit is installed near the sea, the installation parts may be corroded by salt, The installation parts (and the unit) should be taken appropriate anti-corrosion measures.

#### [Inspection Hole Standard]

Number of inspection hole	Distance between false ceiling & actual ceiling	Remarks
1	More than 100 cm	Sufficient space in the ceiling for servicing.
2	20 cm to 100 cm	Insufficient space. Difficult for servicing
Hole size should be more than the size of IDU.	Less than 20 cm	Minimum height for motor replacement.

**Minimum floor area** (for R32)

- The appliance shall be installed, operated and stored in a room with a floor area larger than the minimum area.
- Use the graph of table to determine the minimum area.

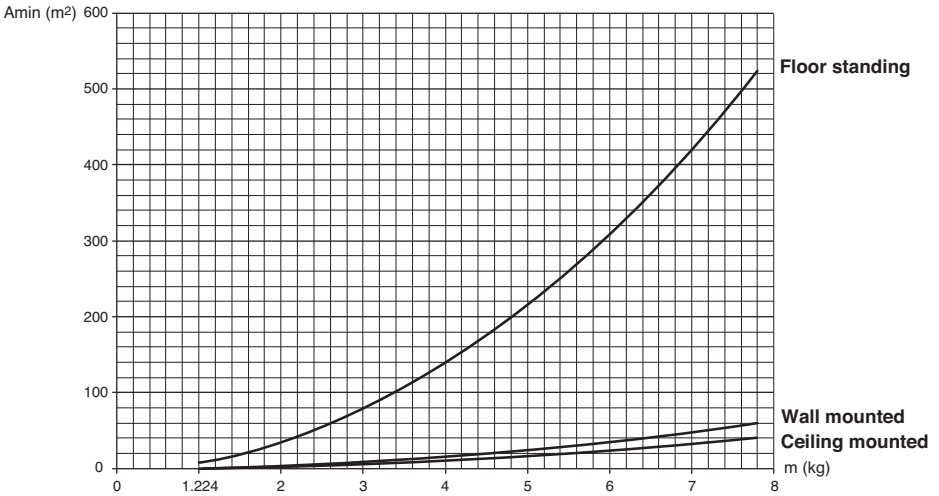

- m : Total refrigerant amount in the system
- Total refrigerant amount : factory refrigerant charge + additional refrigerant amount
- Amin : minimum area for installation

Floor location		Floor location	
m (kg)	Amin (m <sup>2</sup> )	m (kg)	Amin (m <sup>2</sup> )
< 1.224	-	4.6	181.56
1.224	12.9	4.8	197.70
1.4	16.82	5	214.51
1.6	21.97	5.2	232.02
1.8	27.80	5.4	250.21
2	34.32	5.6	269.09
2.2	41.53	5.8	288.65
2.4	49.42	6	308.90
2.6	58.00	6.2	329.84
2.8	67.27	6.4	351.46
3	77.22	6.6	373.77
3.2	87.86	6.8	396.76
3.4	99.19	7	420.45
3.6	111.20	7.2	444.81
3.8	123.90	7.4	469.87
4	137.29	7.6	495.61
4.2	151.36	7.8	522.04
4.4	166.12		

Wall mounted		Wall mounted	
m (kg)	Amin (m <sup>2</sup> )	m (kg)	Amin (m <sup>2</sup> )
< 1.224	-	4.6	20.17
1.224	1.43	4.8	21.97
1.4	1.87	5	23.83
1.6	2.44	5.2	25.78
1.8	3.09	5.4	27.80
2	3.81	5.6	29.90
2.2	4.61	5.8	32.07
2.4	5.49	6	34.32
2.6	6.44	6.2	36.65
2.8	7.47	6.4	39.05
3	8.58	6.6	41.53
3.2	9.76	6.8	44.08
3.4	11.02	7	46.72
3.6	12.36	7.2	49.42
3.8	13.77	7.4	52.21
4	15.25	7.6	55.07
4.2	16.82	7.8	58.00
4.4	18.46		

Ceiling Mounted		Ceiling Mounted	
m (kg)	Amin (m <sup>2</sup> )	m (kg)	Amin (m <sup>2</sup> )
< 1.224	-	4.6	13.50
1.224	0.956	4.8	14.70
1.4	1.25	5	15.96
1.6	1.63	5.2	17.26
1.8	2.07	5.4	18.61
2	2.55	5.6	20.01
2.2	3.09	5.8	21.47
2.4	3.68	6	22.98
2.6	4.31	6.2	24.53
2.8	5.00	6.4	26.14
3	5.74	6.6	27.80
3.2	6.54	6.8	29.51
3.4	7.38	7	31.27
3.6	8.27	7.2	33.09
3.8	9.22	7.4	34.95
4	10.21	7.6	36.86
4.2	11.26	7.8	38.83
4.4	12.36		

## Ceiling dimension and hanging bolt location (Low Static)

### Installation of Unit

Install the unit above the ceiling correctly.

#### POSITION OF SUSPENSION BOLT

- Apply a joint-canvas between the unit and duct to absorb unnecessary vibration.
- Apply a filter Accessory at air return hole.

(Unit:mm)

Dimension Capacity(kBtu/h)	A	B	C	D	E	F	G	H	I	J
L1	733	772	628	700	36	190	20	660	155	700
L2	933	972	628	700	36	190	20	860	155	900
L3	1133	1172	628	700	36	190	20	1060	155	1100

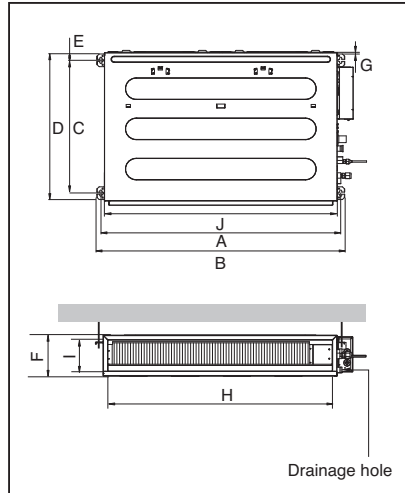

※ Install the unit leaning to a drainage hole side as a figure for easy water drainage.

#### POSITION OF CONSOLE BOLT

- A place where the unit will be leveled and that can support the weight of the unit.
- A place where the unit can withstand its vibration.
- A place where service can be easily performed.

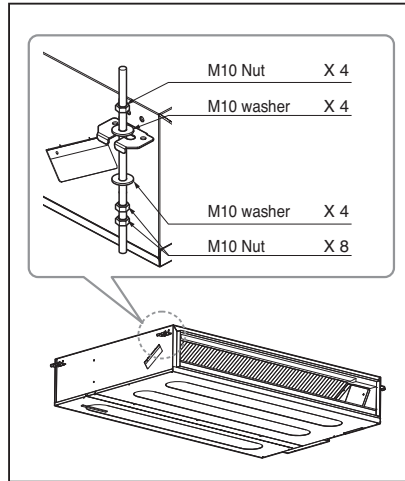

## Ceiling dimension and hanging bolt location (Mid Static)

### ■ Installation of Unit

Install the unit above the ceiling correctly.

#### POSITION OF SUSPENSION BOLT

- Apply a joint-canvas between the unit and duct to absorb unnecessary vibration.
- Install the unit leaning to a drainage hole side as a figure for easy water drainage.
- A place where the unit will be leveled and that can support the weight of the unit.
- A place where the unit can withstand its vibration.
- A place where service can be easily performed.

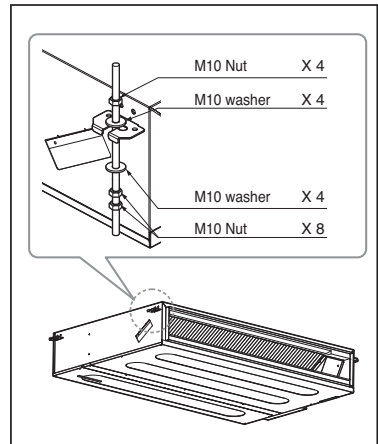
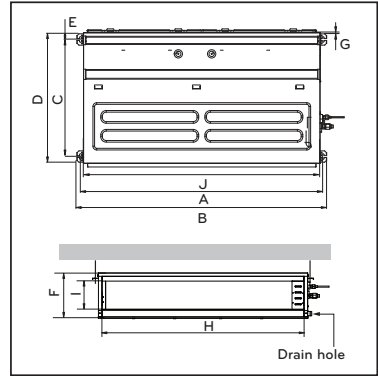

(Unit:mm)

Dimension Chassis name	A	B	C	D	E	F	G	H	I	J
M1	933.4	971.6	619.2	700	30	270	15.2	858	201.4	900
M2	1 283.4	1 321.6	619.2	700	30	270	15.2	1 208	201.4	1 250
M3	1 283.4	1 321.6	619.2	700	30	360	15.2	1 208	291.4	1 250

#### NOTE

- Thoroughly study the following installation locations:
  1. In such places as restaurants and kitchens, considerable amount of oil steam and flour adhere to the fan, the fin of the heat exchanger, resulting in heat exchange reduction, spraying, dispersing of water drops, etc. In these cases, take the following actions:
    - Make sure that the ventilation fan for smoke-collecting hood on a cooking table has sufficient capacity so that it draws oily steam which should not flow into the suction of the air conditioner.
    - Make enough distance from a cooking room to install the air conditioner in such a place where it may not suck in oil steam.
  2. Avoid installing air conditioner in such circumstances where cutting oil mist or iron powder is in suspension in factories, etc.
  3. Avoid places where inflammable gas is generated, flows in, is stored or vented.
  4. Avoid places where sulfurous acid gas or corrosive gas is generated.
  5. Avoid places near high frequency generators.

## Ceiling dimension and hanging bolt location (High Static)

### ■ Installation of Unit

Install the unit above the ceiling correctly.

#### CASE 1

##### POSITION OF SUSPENSION BOLT

- Apply a joint-canvas between the unit and duct to absorb unnecessary vibration.

(Unit:mm)

Dimension	A	B	C	D	E	F	(G)	H	I
Chassis									
BH	932	882	355	47	450	30	87	750	158
BG	1 232	1 182	355	47	450	30	87	830	186
BR	1 282	1 230	477	56	590	30	120	1 006	294

(Unit:mm)

Dimension	A	B	C	D	E	F	G	H	I	J	K	L
Chassis												
B8	1 680	1 565	1 160	330	460	580	700	1 400	1 635	390	445	15

#### CASE 2

- Install the unit leaning to a drainage hole side as a figure for easy water drainage.

##### POSITION OF CONSOLE BOLT

- A place where the unit will be leveled and that can support the weight of the unit.
- A place where the unit can withstand its vibration.
- A place where service can be easily performed.

#### NOTE

- Thoroughly study the following installation locations:

1. In such places as restaurants and kitchens, considerable amount of oil steam and flour adhere to the fan, the fin of the heat exchanger, resulting in heat exchange reduction, spraying, dispersing of water drops, etc.

In these cases, take the following actions:

- Make sure that the ventilation fan for smoke-collecting hood on a cooking table has sufficient capacity so that it draws oily steam which should not flow into the suction of the air conditioner.
  - Make enough distance from a cooking room to install the air conditioner in such a place where it may not suck in oil steam.
2. Avoid installing air conditioner in such circumstances where cutting oil mist or iron powder is in suspension in factories, etc.
  3. Avoid places where inflammable gas is generated, flows in, is stored or vented.
  4. Avoid places where sulfurous acid gas or corrosive gas is generated.
  5. Avoid places near high frequency generators.

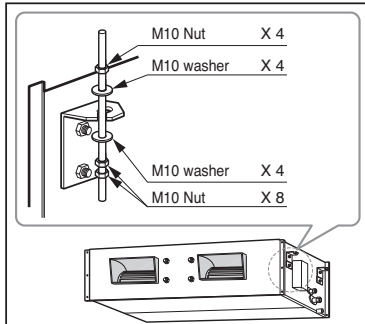
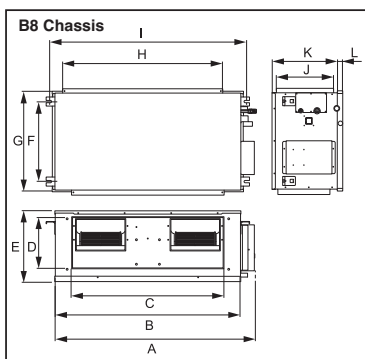
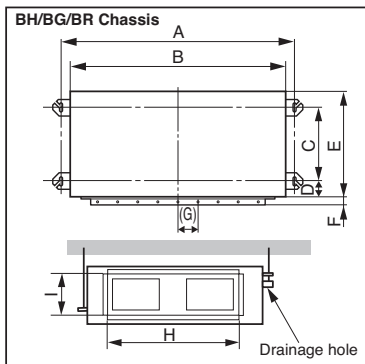

## Indoor Unit Installation

- Select and mark the position for fixing bolts.
- Drill the hole for set anchor on the face of ceiling.

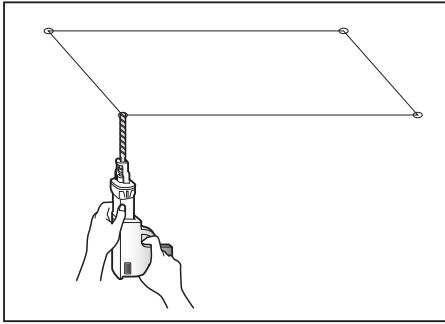

### CAUTION

Tighten the nut and bolt to prevent unit falling.

- Insert the set anchor and washer onto the suspension bolts for locking the suspension bolts on the ceiling.
- Mount the suspension bolts to the set anchor firmly.
- Secure the installation plates onto the suspension bolts (adjust level roughly) using nuts, washers and spring washers.

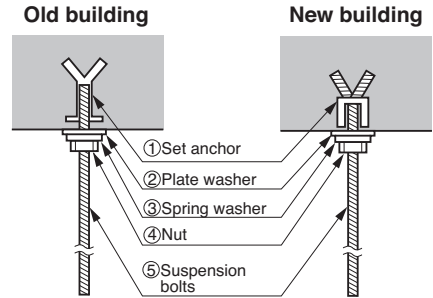

## Wiring Connection

Connect the wires to the terminals on the control board individually according to the outdoor unit connection.

- Ensure that the color of the wires of outdoor unit and the terminal No. are the same as those of indoor unit respectively.
- The installation of a residual current device(RCD) having a rated residual operating current not exceeding 30 mA is advisable.

### Low Static

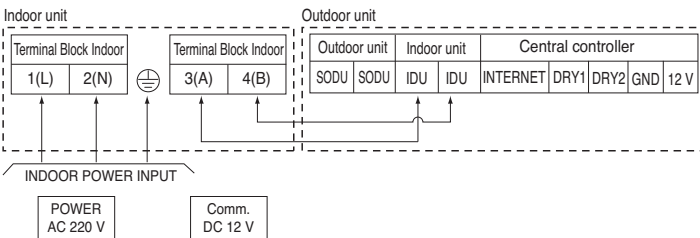

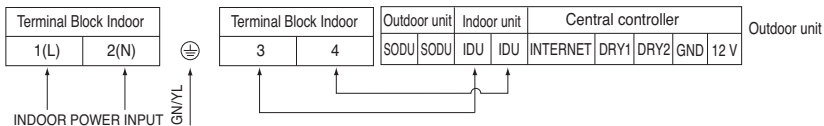
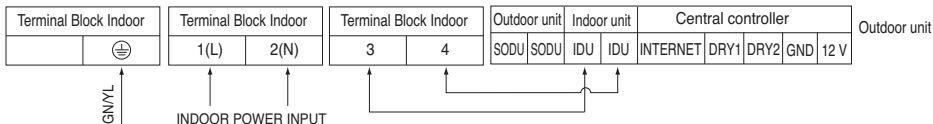
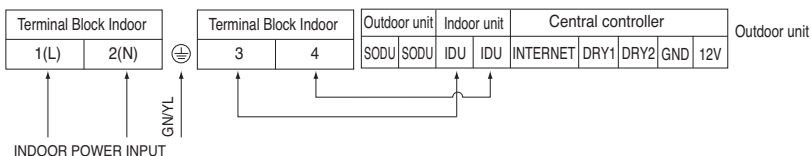
**Mid Static****<M1 Chassis>****<M2/M3 Chassis>****High Static**

- Power Cable: CV 1.5 x 3C

**⚠ WARNING**

Make sure that the screws of the terminal are free from looseness.

**Clamping of cables**

- 1) Arrange 2 power cables on the control panel.
- 2) First, fasten the steel clamp with a screw to the inner boss of control panel.
- 3) For the cooling model, fix the other side of the clamp with a screw strongly. For the heat pump model, put the 0.75 mm<sup>2</sup> cable(thinner cable) on the clamp and tighten it with a plastic clamp to the other boss of the control panel.

**⚠ CAUTION**

The Power cord connected to the unit should be selected according to the following specifications.

\* Pipes and wires should be purchased separately for installation of the product.

## INSULATION, OTHERS

Insulate the joint and tubes completely.

### THERMAL INSULATION

All thermal insulation must comply with local requirement.

#### INDOOR UNIT

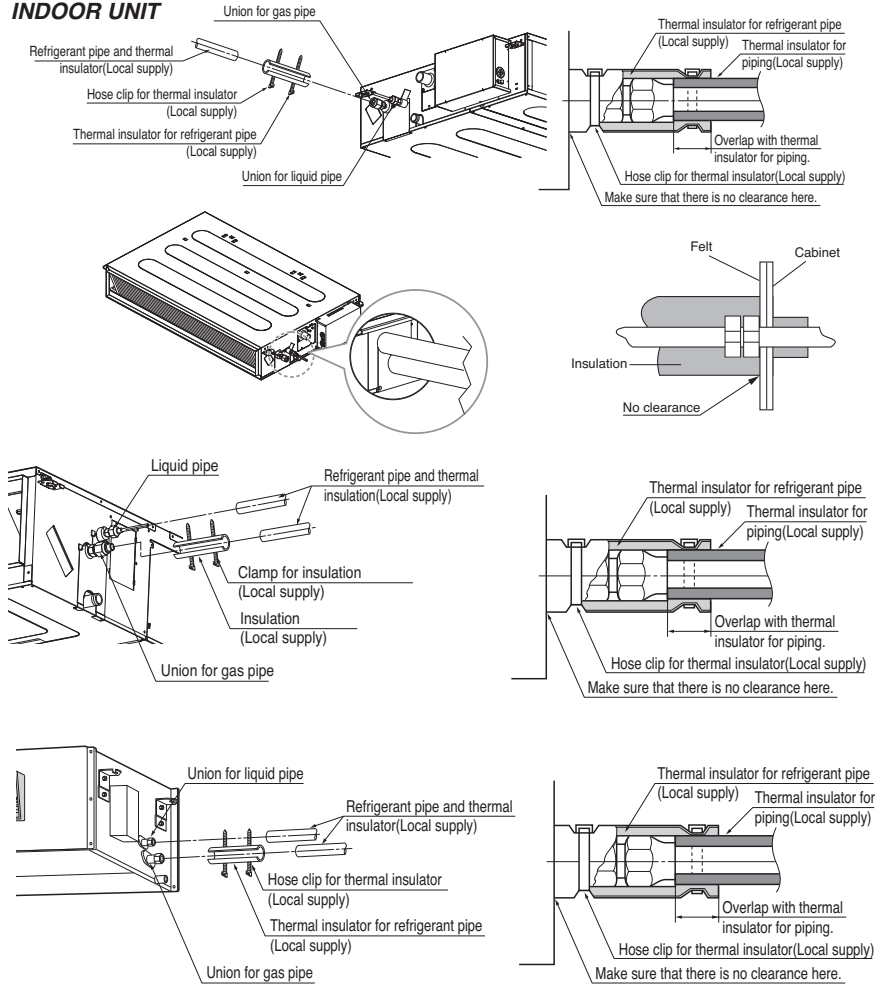

### TEST AND CHECK

■ **After all workings are finished, check the working and operation.**

- Air distribution ..... Is the air circulation good?
- Drain ..... Is the drainage smoothly and no sweating?
- Gas leakage ..... Is the piping connection correctly?
- Wiring ..... Is the wiring connection correctly?
- Lock-bolt ..... Is the lock-bolt of compressor loosened?
- Insulation..... Is the unit fully insulated?
- Ground ..... Is the unit safely grounded?

## Checking the Drainage

### 1. Remove the Air Filter.

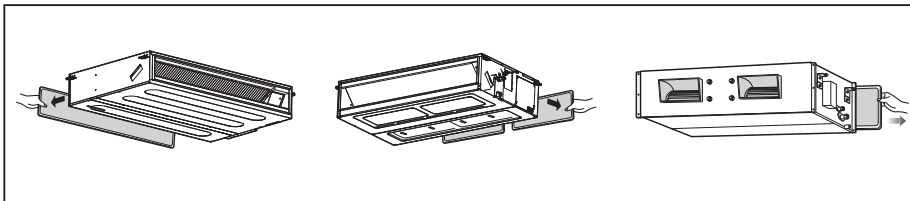

### 2. Check the drainage.

- Spray one or two glasses of water upon the evaporator.
- Ensure that water flows drain hose of indoor unit without any leakage.

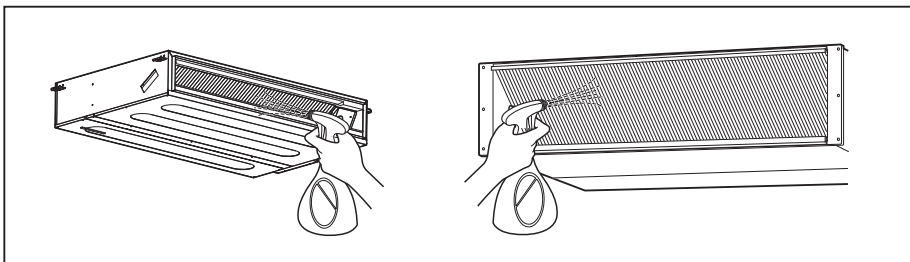

## CAUTION

1. **Install declination** of the indoor unit is very **important for the drain** of the duct type air conditioner.
2. Minimum thickness of the insulation for the connecting pipe shall be 19 mm.

### Front of view

- The unit must be horizontal or declined to the drain hose connected when finished installation.

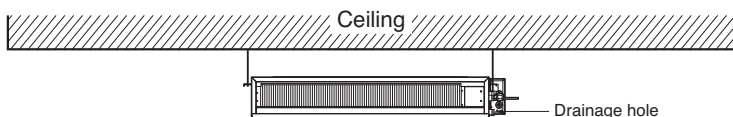

Drain Pump use

## Drain Piping

- Drain piping must have down-slope (1/50 to 1/100): be sure not to provide up-and-down slope to prevent reversal flow.
- During drain piping connection, be careful not to exert extra force on the drain port on the indoor unit.
- The outside diameter of the drain connection on the indoor unit is 32 mm.

Piping material: Polyvinyl chloride pipe VP-25 and pipe fittings

- Be sure to install heat insulation on the drain piping.

Heat insulation material: Polyethylene foam with thickness more than 8 mm.

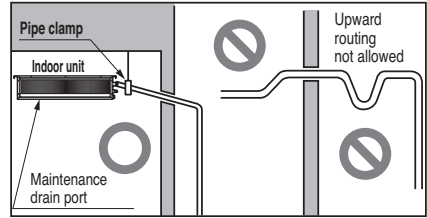

### Drain test

The air conditioner uses a drain pump to drain water. Use the following procedure to test the drain pump operation.

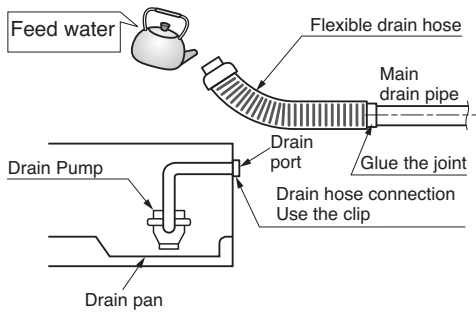

- Connect the main drain pipe to the exterior and leave it provisionally until the test comes to an end.
- Feed water to the flexible drain hose and check the piping for leakage.
- Be sure to check the drain pump for normal operating and noise when electrical wiring is complete.
- When the test is complete, connect the flexible drain hose to the drain port on the indoor unit.

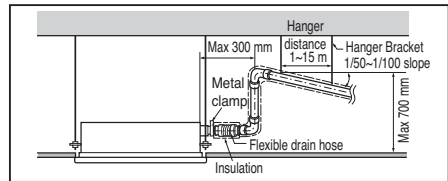

## **⚠ CAUTION**

After the confirmation of the above conditions, prepare the wiring as follows:

- 1) **Never fail to have an individual power specialized for the air conditioner. As for the method of wiring, be guided by the circuit diagram posted on the inside of control box cover.**
- 2) **Provide a circuit breaker switch between power source and the unit.**
- 3) **The screws which fasten the wiring in the casing of electrical fittings are liable to come loose from vibrations to which the unit is subjected during the course of transportation. Check them and make sure that they are all tightly fastened. (If they are loose, it could give rise to burn-out of the wires.)**
- 4) **Specification of power source**
- 5) **Confirm that electrical capacity is sufficient.**
- 6) **Be sure that the starting voltage is maintained at more than 90 percent of the rated voltage marked on the name plate.**
- 7) **Confirm that the cable thickness is as specified in the power sources specification. (Particularly note the relation between cable length and thickness.)**
- 8) **Never fail to equip a leakage breaker where it is wet or moist.**
- 9) **The following troubles would be caused by voltage drop-down.**
  - Vibration of a magnetic switch, damage on the contact point, fuse breaking, disturbance by the normal function of an overload protection device.
  - Proper starting power is not given to the compressor.

## **HAND OVER**

Teach the customer the operation and maintenance procedures, using the operation manual. (air filter cleaning, temperature control, etc.)

## DIP Switch Setting

### 1. Indoor Unit

	Function	Description	Setting Off	Setting On	Default
SW1	Communication	N/A (Default)	-	-	Off
SW2	Cycle	N/A (Default)	-	-	Off
SW3	Group Control	Selection of Master or Slave	Master	Slave	Off
SW4	Dry Contact Mode	Selection of Dry Contact Mode	Wired/Wireless remote controller selection of Manual or Auto operation Mode	Auto	Off
SW5	Installation	Fan continuous operation	Continuous operation Removal	-	Off
SW6	Heater linkage	N/A	-	-	Off
SW7	Ventilator linkage	Selection of Ventilator linkage	Linkage Removal	Working	Off
	Vane selection (Console)	Selection of up/down side Vane	Up side + Down side Vane	Up side Vane Only	
	Region selection	Selection tropical region	General model	Tropical model	
SW8	Etc.	Spare	-	-	Off



### **CAUTION**

**For Multi V Models, DIP switch 1, 2, 6, 8 must be set OFF.**

## Group Control Setting

### 1. Group Control 1

#### ■ Wired remote controller 1 + Standard Indoor Units

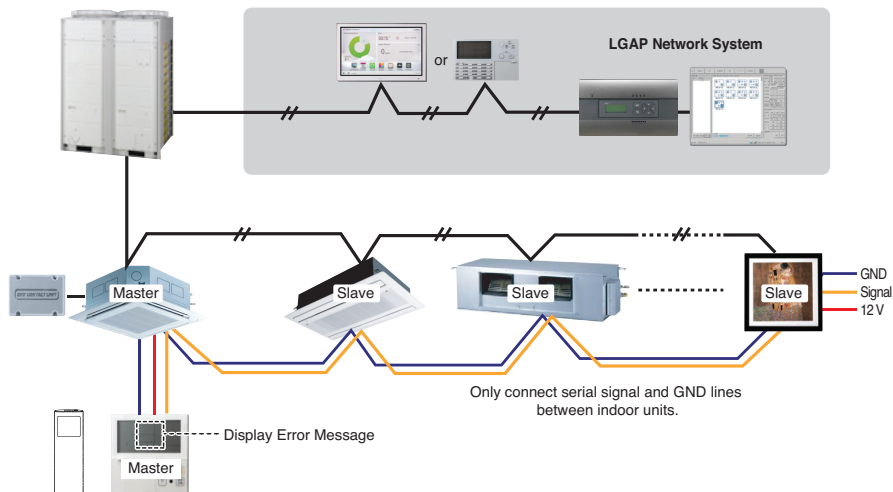

#### ■ DIP Switch in PCB

##### ① Master Setting - No. 3 Off

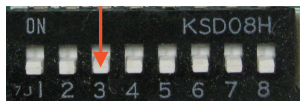

##### ② Slave Setting - No. 3 On

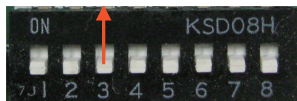

Indoor Unit DIP Switch

Some products have no DIP switch on PCB. It is possible to set indoor units to Master or Slave by using the wireless remote controller instead of DIP switch.

For the details of the setting, please refer to the manual of the wireless remote controller.

#### 1. It is possible to 16 indoor units(Max.) by one wired remote controller.

Set one indoor unit to Master, set the others to Slave.

#### 2. It is possible to connect with every type of indoor units.

#### 3. It is possible to use wireless remote controller at the same time.

#### 4. It is possible to connect with Dry Contact and Central controller at the same time.

- The Master indoor unit is possible to recognize Dry Contact and Central Controller only.

#### 5. In case that any error occurs at indoor unit, the error code is displayed on the wired remote controller.

It is possible to control the other indoor units except the error units.

- \* It is possible to connect indoor units since Feb. 2009.
- \* It can be the cause of malfunctions when there is no setting of master and slave.
  
- \* In case of Group Control, it is possible to use following functions.
  - Selection of operation, stop or mode
  - Temperature setting and room temperature check
  - Current time change
  - Control of flow rate (High/Middle/Low)
  - Reservation settings
- It is not possible to use some functions.

## 2. Group Control 2

### ■ Wired remote controllers + Standard Indoor Units

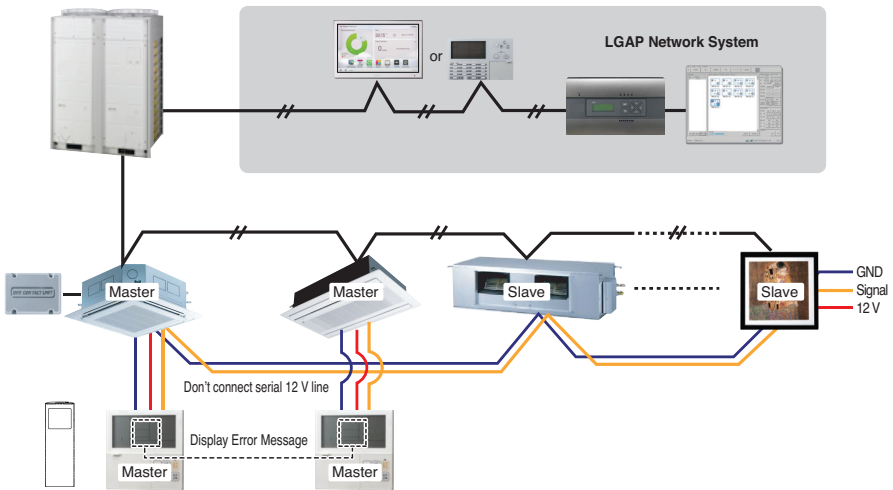

- \* It is possible to control 16 indoor units(Max.) with the master wired remote control.
- \* Other than those, it is same with the Group Control 1.

### 3. Group Control 3

#### ■ Mixture connection with indoor units and Fresh Air Intake Unit

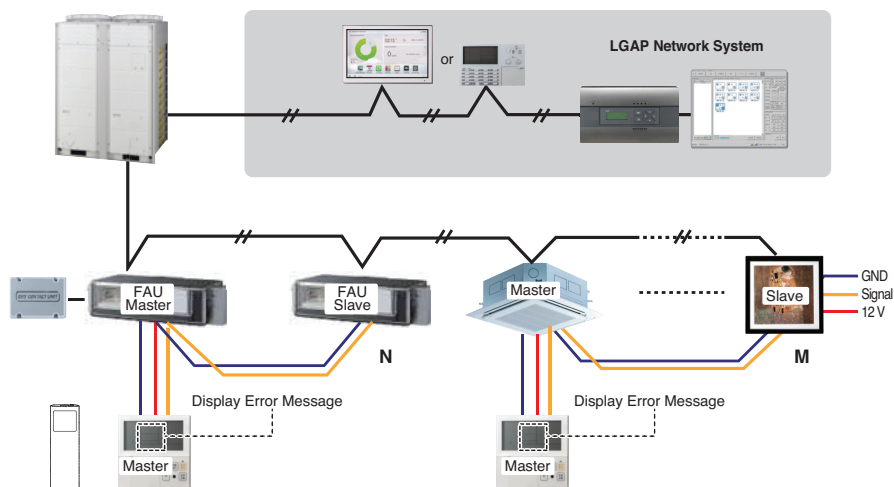

※ In case of connecting with standard indoor unit and Fresh Air Intake Unit, separate Fresh Air Intake Unit with standard units. ( $N, M \leq 16$ ) (Because setting temperature are different.)

※ Other than those, it is same with Group Control 1.



\* FAU : Fresh Air Intake Unit  
Standard: Standard Indoor Unit

## 4. 2 Remote Control

### ■ Wired remote controller 2 + Indoor unit 1

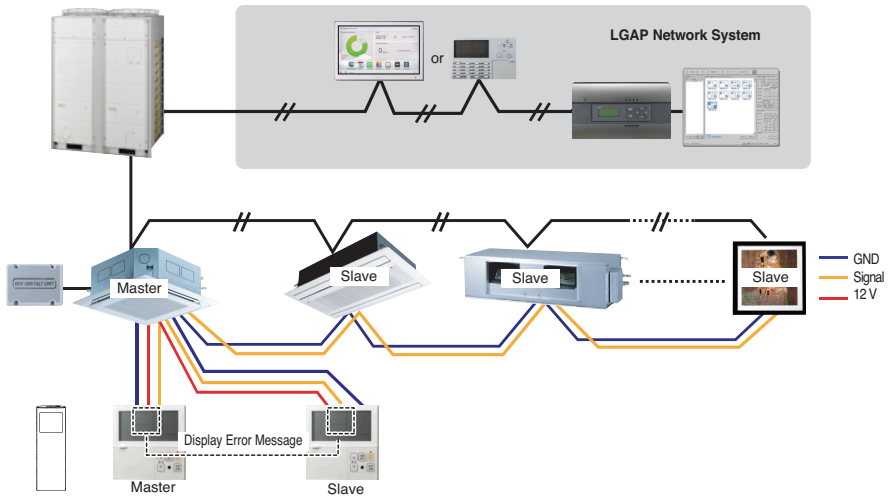

1. It is possible to connect two wired remote controllers (Max.) with one indoor unit.  
Set only one indoor unit to Master, set the others to Slave.  
Set only one wired remote controller to Master, set the others to Slave.
2. Every types of indoor unit is possible to connect two remote controller.
3. It is possible to use wireless remote controller at the same time.
4. It is possible to connect with Dry Contact and Central controller at the same time.
5. In case that any error occurs at indoor unit, the error code is displayed on the wired remote controller.
6. There isn't limits of indoor unit function.

## 5. Accessories for group control setting

It is possible to set group control by using below accessories.

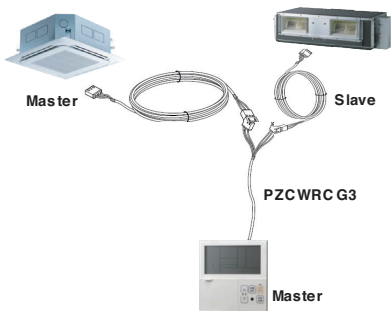
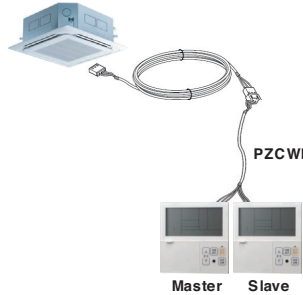
Indoor unit 2 EA +Wired remote controller	Indoor unit 1 EA +Wired remote controller 2 EA
<p>※ PZCWRCG3 cable used for connection</p> 	<p>※ PZCWRC2 cable used for connection</p> 

### ⚠ CAUTION

- Apply totally enclosed noncombustible conduit in case of local building code Requiring plenum cable usage.

## Model Designation

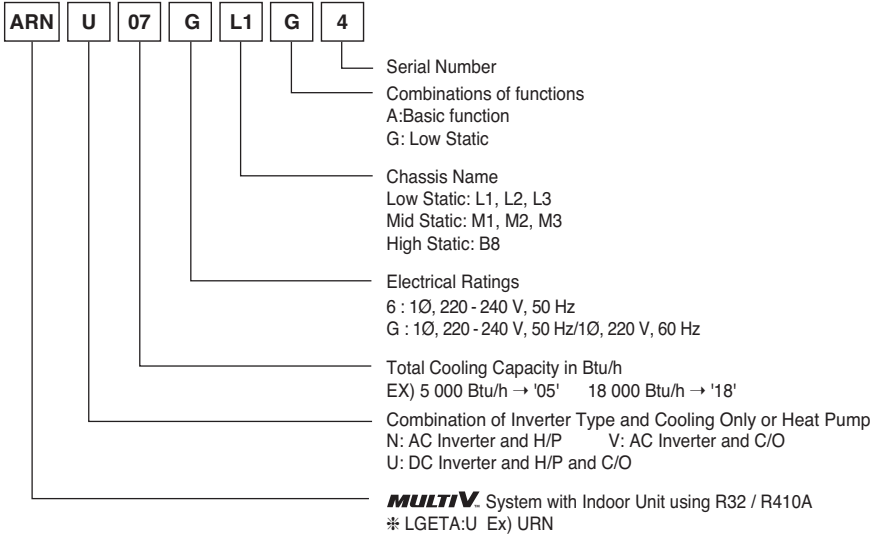

## Airborne Noise Emission

The A-weighted sound pressure emitted by this product is below 70 dB.

\*\* The noise level can vary depending on the site.

The figures quoted are emission level and are not necessarily safe working levels. Whilst there is a correlation between the emission and exposure levels, this cannot be used reliably to determine whether or not further precautions are required. Factors that influence the actual level of exposure of the workforce include the characteristics of the work room and the other sources of noise, i.e. the number of equipment and other adjacent processes and the length of time for which an operator is exposed to the noise. Also, the permissible exposure level can vary from country to country. This information, however, will enable the user of the equipment to make a better evaluation of the hazard and risk.

## Limiting concentration

Limiting concentration is the limit of Freon gas concentration where immediate measures can be taken without hurting human body when refrigerant leaks in the air. The limiting concentration shall be described in the unit of kg/m<sup>3</sup> (Freon gas weight per unit air volume) for facilitating calculation

**Limiting concentration: 0.44 kg/m<sup>3</sup>(R410A)**

### ■ Calculate refrigerant concentration

$$\text{Refrigerant concentration} = \frac{\text{Total amount of replenished refrigerant in refrigerant facility (kg)}}{\text{Capacity of smallest room where indoor unit is installed (m}^3\text{)}}$$

# How to Set E.S.P.?

## L1 Chassis : 05, 07, 09 k

(Unit : CMM)

Setting Value	Static Pressure(mmAq(Pa))					
	0 (0)	1 (10)	2 (20)	3 (29)	4 (39)	5 (49)
60	-	-	-	-	-	-
65	5.03	-	-	-	-	-
70	5.60	4.85	-	-	-	-
75	6.19	5.44	4.57	-	-	-
80	6.79	6.05	5.17	-	-	-
85	7.41	6.67	5.80	4.80	-	-
90	8.05	7.31	6.43	5.44	-	-
95	8.71	7.96	7.09	6.09	4.97	-
100	9.38	8.63	7.76	6.76	5.64	-
105	10.07	9.32	8.45	7.45	6.33	5.08
110	-	10.03	9.16	8.16	7.04	5.79
115	-	-	9.88	8.88	7.76	6.51
120	-	-	-	9.62	8.50	7.25
125	-	-	-	10.38	9.26	8.01
130	-	-	-	-	10.03	8.78

## L2 Chassis : 12, 15, 18 k

(Unit : CMM)

Setting Value	Static Pressure(mmAq(Pa))					
	0 (0)	1 (10)	2 (20)	3 (29)	4 (39)	5 (49)
75	6.50	-	-	-	-	-
80	7.34	6.70	-	-	-	-
85	8.20	7.55	6.69	-	-	-
90	9.07	8.43	7.56	6.47	-	-
95	9.96	9.32	8.45	7.36	-	-
100	10.87	10.22	9.36	8.27	6.96	-
105	11.79	11.15	10.28	9.19	7.89	6.35
110	12.73	12.09	11.22	10.14	8.83	7.30
115	13.69	13.05	12.18	11.09	9.78	8.25
120	14.67	14.02	13.16	12.07	10.76	9.23
125	15.66	15.01	14.15	13.06	11.75	10.22
130	16.67	16.02	15.16	14.07	12.76	11.23
135	-	-	16.18	15.10	13.79	12.26
140	-	-	-	16.14	14.83	13.30
145	-	-	-	-	15.89	14.36

## L3 Chassis : 21, 24 k

(Unit : CMM)

Setting Value	Static Pressure(mmAq(Pa))					
	0 (0)	1 (10)	2 (20)	3 (29)	4 (39)	5 (49)
85	10.19	-	-	-	-	-
90	12.18	10.71	11.09	-	-	-
95	13.81	12.34	12.19	-	-	-
100	15.16	13.69	13.38	10.71	-	-
105	16.30	14.83	14.36	11.85	-	-
110	17.31	15.85	15.23	12.86	10.97	-
115	18.27	16.80	16.07	13.82	11.93	-
120	19.26	17.79	16.93	14.80	12.91	10.49
125	20.34	18.87	17.89	15.88	13.99	11.57
130	21.60	20.13	19.01	17.14	15.25	12.83
135	-	21.64	20.36	18.66	16.76	14.35
140	-	-	22.01	20.50	18.61	16.19
145	-	-	-	22.75	20.86	18.44

### Note :

1. The above table shows the correlation between the air rates and E.S.P.
2. Please refer wired remote controller manual for E.S.P setting procedure.

**M1 Chassis : 7, 9, 12, 15, 18 k**

(Unit: CMM)

Setting value	Static Pressure (mmAq(Pa))							
	2.5(25)	4(39)	6(59)	8(78)	10(98)	12(118)	14(137)	15(147)
70	11.3	-	-	-	-	-	-	-
75	12.8	-	-	-	-	-	-	-
80	14.4	11.4	-	-	-	-	-	-
85	15.9	13.2	10.2	-	-	-	-	-
90	17.5	15.0	12.0	-	-	-	-	-
95	19.0	16.7	13.7	10.7	-	-	-	-
100	20.6	18.5	15.5	12.5	-	-	-	-
105	22.1	20.3	17.3	14.3	11.1	-	-	-
110	23.7	22.1	19.0	16.1	13.1	10.0	-	-
115	-	23.8	20.8	17.9	15.1	12.2	-	-
120	-	-	22.6	19.7	17.1	14.3	11.3	-
125	-	-	-	21.5	19.1	16.5	13.6	11.9
130	-	-	-	23.3	21.2	18.7	15.8	14.3
135	-	-	-	-	23.2	20.8	18.0	16.7
140	-	-	-	-	-	23.0	20.3	19.1
145	-	-	-	-	-	-	22.5	21.5
150	-	-	-	-	-	-	-	23.8

**M1 Chassis : 24 k**

(Unit: CMM)

Setting value	Static Pressure (mmAq(Pa))							
	2.5(25)	4(39)	6(59)	8(78)	10(98)	12(118)	14(137)	15(147)
85	16.8	14.6	-	-	-	-	-	-
90	18.1	15.9	-	-	-	-	-	-
95	19.4	17.2	15.0	-	-	-	-	-
100	20.7	18.5	16.3	13.9	-	-	-	-
105	22.0	19.8	17.7	15.3	13.0	-	-	-
110	23.3	21.1	19.1	16.8	14.6	-	-	-
115	24.6	22.4	20.5	18.3	16.3	14.2	-	-
120	25.9	23.7	21.8	19.7	17.9	15.9	13.3	-
125	-	25.1	23.2	21.2	19.6	17.5	15.2	14.6
130	-	-	24.6	22.7	21.2	19.2	17.1	16.3
135	-	-	-	24.2	22.9	20.9	19.0	18.1
140	-	-	-	-	24.5	22.6	20.9	19.9

- Note: 1. The above table shows the correlation between the air rates and E.S.P.  
 2. Make sure to check and adjust E.S.P (external static pressure) value after the installation of the product. Otherwise, there is a risk of weak cooling/heating and condensed water discharge/drop.

**M2 Chassis : 7, 9, 12, 15 k**

(Unit: CMM)

Setting value	Static Pressure (mmAq(Pa))							
	4(39)	6(59)	8(78)	10(98)	12(118)	14(137)	16(157)	18(177)
65	4.7	-	-	-	-	-	-	-
70	10.3	-	-	-	-	-	-	-
75	15.0	-	-	-	-	-	-	-
80	19.0	7.6	-	-	-	-	-	-
85	24.9	13.8	4.9	-	-	-	-	-
90	27.6	20.4	7.8	-	-	-	-	-
95	30.4	24.4	15.7	5.2	-	-	-	-
100	33.1	28.7	20.8	9.2	3.8	-	-	-
105	35.9	31.7	24.1	17.5	6.7	-	-	-
110	38.6	34.7	30.5	22.2	11.5	5.5	-	-
115	40.1	37.8	33.8	27.9	20.2	9.1	-	-
120	-	39.1	37.1	31.4	24.6	17.9	7.5	-
125	-	-	38.5	35.0	30.1	21.2	11.0	6.7
130	-	-	-	37.1	32.0	27.6	15.6	10.0
135	-	-	-	-	36.8	31.5	24.3	16.2
140	-	-	-	-	40.5	35.9	29.8	22.4
145	-	-	-	-	-	39.9	34.9	27.8
150	-	-	-	-	-	-	39.4	34.2
155	-	-	-	-	-	-	-	37.1

**M2 Chassis : 28, 36 k**

(Unit: CMM)

Setting value	Static Pressure (mmAq(Pa))							
	4(39)	6(59)	8(78)	10(98)	12(118)	14(137)	16(157)	18(177)
65	4.7	-	-	-	-	-	-	-
70	10.3	-	-	-	-	-	-	-
75	15.0	-	-	-	-	-	-	-
80	19.0	7.6	-	-	-	-	-	-
85	24.9	13.8	4.9	-	-	-	-	-
90	27.6	20.4	7.8	-	-	-	-	-
95	30.4	24.4	15.7	5.2	-	-	-	-
100	33.1	28.7	20.8	9.2	3.8	-	-	-
105	35.9	31.7	24.1	17.5	6.7	-	-	-
110	38.6	34.7	30.5	22.2	11.5	5.5	-	-
115	40.1	37.8	33.8	27.9	20.2	9.1	-	-
120	-	39.1	37.1	31.4	24.6	17.9	7.5	-
125	-	-	38.5	35.0	30.1	21.2	11.0	6.7
130	-	-	-	37.1	32.0	27.6	15.6	10.0
135	-	-	-	-	36.8	31.5	24.3	16.2
140	-	-	-	-	40.5	35.9	29.8	22.4
145	-	-	-	-	-	39.9	34.9	27.8
150	-	-	-	-	-	-	39.4	34.2
155	-	-	-	-	-	-	-	37.1

- Note: 1. The above table shows the correlation between the air rates and E.S.P.  
 2. Make sure to check and adjust E.S.P (external static pressure) value after the installation of the product. Otherwise, there is a risk of weak cooling/heating and condensed water discharge/drop.

**M2 Chassis : 42 k**

(Unit: CMM)

Setting value	Static Pressure (mmAq(Pa))							
	4(39)	6(59)	8(78)	10(98)	12(118)	14(137)	16(157)	18(177)
90	23.0	-	-	-	-	-	-	-
95	25.9	19.1	-	-	-	-	-	-
100	28.6	23.3	-	-	-	-	-	-
105	31.4	26.4	19.6	-	-	-	-	-
110	34.2	29.9	24.2	-	-	-	-	-
115	36.6	32.7	28.8	21.7	-	-	-	-
120	39.2	35.7	31.8	26.2	19.6	-	-	-
125	41.7	38.5	34.8	30.8	24.3	-	-	-
130	44.0	41.2	37.7	34.1	29.0	22.3	-	-
135	-	43.8	40.7	37.4	32.6	27.5	20.5	-
140	-	-	43.5	40.4	37.2	32.6	25.8	19.9
145	-	-	-	43.4	41.6	37.4	30.7	24.6
150	-	-	-	-	43.4	42.3	35.4	29.4
155	-	-	-	-	-	43.7	37.5	32.7

**M3 Chassis : 18, 24, 28 k**

(Unit: CMM)

Setting value	Static Pressure (mmAq(Pa))								
	4(39)	6(59)	8(78)	10(98)	12(118)	14(137)	16(157)	18(177)	20(196)
70	25.2	-	-	-	-	-	-	-	-
75	30.4	21.4	-	-	-	-	-	-	-
80	35.0	27.2	18.5	-	-	-	-	-	-
85	39.8	35.4	24.6	-	-	-	-	-	-
90	44.3	40.1	31.5	22.7	-	-	-	-	-
95	49.3	44.8	36.8	28.8	21.4	-	-	-	-
100	53.0	49.4	44.6	35.4	27.7	-	-	-	-
105	57.2	54.1	49.2	43.0	35.0	26.5	-	-	-
110	-	58.8	53.9	47.9	42.4	33.8	24.3	14.8	-
115	-	-	58.6	52.9	47.8	42.5	31.4	20.3	18.3
120	-	-	-	57.8	53.1	48.2	39.2	30.2	24.6
125	-	-	-	-	-	49.4	43.1	36.7	33.1
130	-	-	-	-	-	52.7	48.6	44.4	39.6
135	-	-	-	-	-	-	-	50.2	45.2

**M3 Chassis : 48, 54 k**

(Unit: CMM)

Setting value	Static Pressure (mmAq(Pa))						
	5(49)	6(59)	8(78)	10(98)	12(118)	14(137)	15(147)
70	25.1	-	-	-	-	-	-
75	29.5	26.1	-	-	-	-	-
80	34.0	30.8	25.9	-	-	-	-
85	38.4	35.4	30.6	23.2	-	-	-
90	42.9	40.1	35.2	28.1	21.0	-	-
95	47.3	44.8	39.9	33.1	26.3	19.5	-
100	51.8	49.4	44.6	38.0	31.7	25.2	22.6
105	56.2	54.1	49.2	43.0	37.1	31.0	28.5
110	-	58.8	53.9	47.9	42.4	36.7	34.4
115	-	-	58.6	52.9	47.8	42.5	40.3
120	-	-	-	57.8	53.1	48.2	46.1
125	-	-	-	-	54.2	49.4	47.3

Note: 1. The above table shows the correlation between the air rates and E.S.P.

2. Make sure to check and adjust E.S.P (external static pressure) value after the installation of the product. Otherwise, there is a risk of weak cooling/heating and condensed water discharge/drop.

**B8 Chassis : 36, 42, 48, 76, 96 k**

(Unit: CMM)



Setting Value	Static Pressure(mmAq(Pa))											
	3(29)	4(39)	5(49)	6(59)	9(88)	12(118)	15(147)	18(177)	20(196)	22(216)	23(226)	25(245)
50	40.3	36.2	-	-	-	-	-	-	-	-	-	-
55	48.8	44.2	36.4	-	-	-	-	-	-	-	-	-
60	54.9	50.2	49.7	45.0	-	-	-	-	-	-	-	-
65	62.6	60.4	55.1	52.9	-	-	-	-	-	-	-	-
70	67.9	64.5	62.1	60.7	47.1	-	-	-	-	-	-	-
75	75.5	72.2	69.0	68.5	56.9	44.7	-	-	-	-	-	-
80	82.6	80.9	76.6	75.4	69.7	55.2	-	-	-	-	-	-
85	88.8	85.9	82.0	81.6	78.6	67.4	55.9	-	-	-	-	-
91	94.7	93.0	90.4	90.2	87.1	78.9	67.6	54.2	-	-	-	-
95	-	-	-	-	-	86.1	77.0	66.4	50.6	30.0	-	-
100	-	-	-	-	-	88.3	84.9	75.9	69.5	60.8	43.1	-
105	-	-	-	-	-	88.3	84.9	81.1	77.4	72.0	67.9	51.3

- Note: 1. The above table shows the correlation between the air rates and E.S.P.  
 2. Make sure to check and adjust E.S.P (external static pressure) value after the installation of the product. Otherwise, there is a risk of weak cooling/heating and condensed water discharge/drop.

## How to Set Auto ESP (Air conditioner)

- This function automatically sets the rotation speed of the fans corresponding to each step of rated airflow for easy installation.
- Auto ESP setting is required by remote control
- ※ For details, refer to the remote control manual

### <Type 1>

1. If  button is pressed so long for over 3 seconds, it enters to the installer setting mode.
2. Use the   buttons to enter 68-02 and set the Value2 value.  
Refer to the table below for Value2 values. (It takes approximately 3 to 8 minutes.)
3. Once the set-up is complete, you can enter installer setup (68) to check whether the set-up has succeeded or failed. (03: Success, 04: Failure)

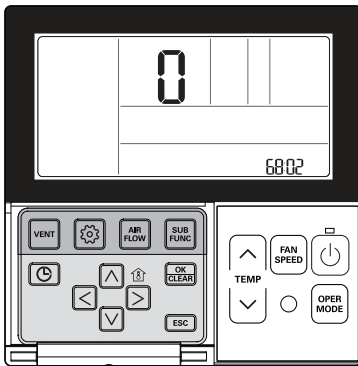

Value 2 : Manual step

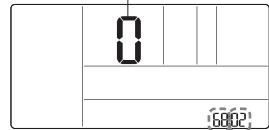

Code value

Value 1 : Auto ESP mode

Value 1 (Auto ESP mode)	Value 2 (Manual Step)	Description (Voltage setting)
00 (Not use)	-	-
01 (Auto)	-	-
02 (Manual)	0	190 V
	1	200 V
	2	210 V
	3	220 V
	4	230 V
	5	240 V
	6	250 V
	7	260 V
8	270 V	
03	-	Cannot be set, only monitoring is possible. If the value1 is 03, setting is successful.
04	-	Cannot be set, only monitoring is possible. If the value1 is 04, setting has failed.

**<Type 2>**

1. Enter the installer mode on the remote control and select Auto ESP.
2. Select the setting category, and press [^ (up)] button for 3 seconds to enter the password input screen for the installer setting.
3. Input the password and press [OK] button to move to the installer setting list. And Select Auto ESP.
4. After selecting "Manual", set the Voltage(190V - 270V) as shown in the screen.
5. It takes about 3-8 minutes to set, and you can see the setting result as Pass or Fail.

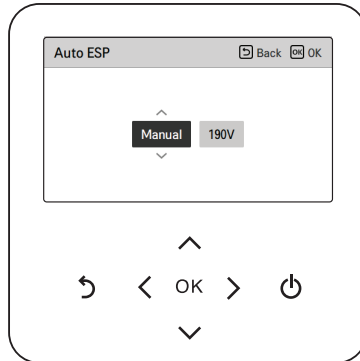
**NOTE**

If Auto ESP is incorrectly set, the air conditioner may malfunction.  
 This function must be set by an installation specialist with an installation license.  
 This function is an additional function of the product and may not work in some models.  
 Wired remote control does not work while 'Auto ESP' is set.





Manufacturer :

LG Electronics Inc.

84, Wanam-ro, Seongsan-gu, Changwon-si, Gyeongsangnam-do, KOREA

UK Importer : LG Electronics U.K. Ltd

Velocity 2, Brooklands Drive, Weybridge, KT13 0SL

**Eco design requirement**

- The information for Eco design is available on the following free access website.  
<https://www.lg.com/global/support/cedoc/cedoc>