



ENGLISH

ITALIANO

ESPAÑOL

FRANÇAIS

DEUTSCH

PORTUGUÊS

中文

# INSTALLATION MANUAL

# AIR CONDITIONER

Please read this installation manual completely before installing the product.  
Installation work must be performed in accordance with the national wiring standards by authorized personnel only.  
Please retain this installation manual for future reference after reading it thoroughly.

Applied(AHU)  
AHU CONTROLLER  
Original instruction



MFL69940001  
Rev.07\_010626

[www.lg.com](http://www.lg.com)

Copyright © 2017 - 2026 LG Electronics Inc. All Rights Reserved.

## SAFETY INSTRUCTIONS

The following safety guidelines are intended to prevent unforeseen risks or damage from unsafe or incorrect operation of the appliance. The guidelines are separated into 'WARNING' and 'CAUTION' as described below.

 This symbol is displayed to indicate matters and operations that can cause risk.

Read the part with this symbol carefully and follow the instructions in order to avoid risk.

### **WARNING**

This indicates that the failure to follow the instructions can cause serious injury or death.

### **CAUTION**

This indicates that the failure to follow the instructions can cause the minor injury or damage to the product.

### **WARNING**

- Installation or repairs made by unqualified persons can result in hazards to you and others.
- The information contained in the manual is intended for use by a qualified service technician familiar with safety procedures and equipped with the proper tools and test instruments.
- Failure to carefully read and follow all instructions in this manual can result in equipment malfunction, property damage, personal injury and/or death.

### Installation

- For installation of the product, always contact the service center or a professional installation agency.
  - Otherwise, it may cause fire, electrical shock, explosion or injury.
- Securely attach the electrical part cover to AHU Comm. Kit.
  - If the electric part cover of AHU Comm. Kit is not attached securely, it could result in a fire or electric shock due to dust, water, etc.

- Do not keep or use flammable gases or combustibles near the equipment.
  - Otherwise, it may cause a fire or the failure of product.
- Do not install, remove or reinstall the unit by yourself.
  - Otherwise, it may cause a fire, electrical shock, explosion or injury.
- Do not disassemble or repair the product randomly.
  - It will cause a fire or electrical shock.
- Do not install the product in a place where there is the concern of falling down.
  - Otherwise, it may result in personal injury.
- Use caution when unpacking and installing.
  - Sharp edges may cause injury.
- Always ground the product.
  - There is risk of fire or electric shock.
- Do not install the product on a non-parallel or defective installation stand.
  - It may cause injury, accident, or damage to the product.

## Operation

- Keep flames away.
  - Otherwise, may occur a fire.
- Do not use the power cord near the heating tools.
  - Otherwise, it may cause a fire and electrical shock.
- Do not allow water to run into electrical parts.
  - Otherwise, it may cause the failure of machine or electrical shock.
- Be cautious that water could not enter the product.
  - Otherwise, it may cause a fire electrical shock or product damage.
- Do not place a heavy object on the power cord.
  - Otherwise, it may cause a fire or electrical shock.
- When the product is submerged into water, always contact the service center.
  - Otherwise, it may cause a fire or electrical shock.
- The Ingress Protection Marking given in this manual as IP20 restricts installation location, LG Electronics is not responsible for installation locations non-compliant to IP20.

## CAUTION

### Installation

- Do not install the product in direct sunlight.
- If anyone other than a licensed professional installs, repairs, or alters LG Electronics air conditioning products, the warranty is voided.
  - All costs associated with repair are then the full responsibility of the owner.
- Do not insert a drain hose in drain or soil pipe.
  - Bad smells can occur and it results in a corrosion of a heat exchanger or pipe.
- Do not install the unit in potentially explosive atmospheres.
- (Australia only) This product must be installed by a professional installer.
- After the installation of the product in the customer premises, fully remove all product packaging (including any expanded or moulded plastic packaging materials) and recycle or dispose of such packaging responsibly. Do not dispose any expanded plastic packaging in the household bin.

### Operation

- This appliance is not intended for use by persons (including children) with reduced physical, sensory or mental capabilities, or lack of experience and knowledge, unless they have been given supervision or instruction concerning use of the appliance by a person responsible for their safety.
  - Children should be supervised to ensure that they do not play with the appliance.
  - Appliances not accessible to the general public.
- This appliance can be used by children aged from 8 years and above and persons with reduced physical, sensory or mental capabilities or lack of experience and knowledge if they have been given supervision or instruction concerning use of the appliance in a safe way and understand the hazards involved. Children shall not play with the appliance. Cleaning and user maintenance shall not be made by children without supervision.

# TABLE OF CONTENTS

---

## 2 SAFETY INSTRUCTIONS

---

## 6 INSTALLATION LAYOUT

---

## 7 TECHNICAL SPECIFICATION

---

## 8 CONTROLLER MODULE

---

## 9 COMMUNICATION KIT

9 Mechanical installation

---

## 11 THERMISTORS INSTALLATION

---

## 12 RETURN AIR TEMPERATURE CONTROL (PAHCMR000)

12 DIP SW

---

## 25 DISCHARGE AIR TEMPERATURE CONTROL (PAHCMS000)

25 Main Module DIP SW

---

## 37 EXTERNAL CONNECTION DIAGRAM

37 Return air temperature control

---

## 41 BMS PROTOCOL

41 BACnet points of PAHCMR000 (Return air temperature control)

---

## 47 CONNECTION & SETTING GUIDE

---

## 50 COMMUNICATION MODULE & EEV KIT CONNECTION GUIDE

---

## 52 COMMKIT ERRORCODE

---

# INSTALLATION LAYOUT

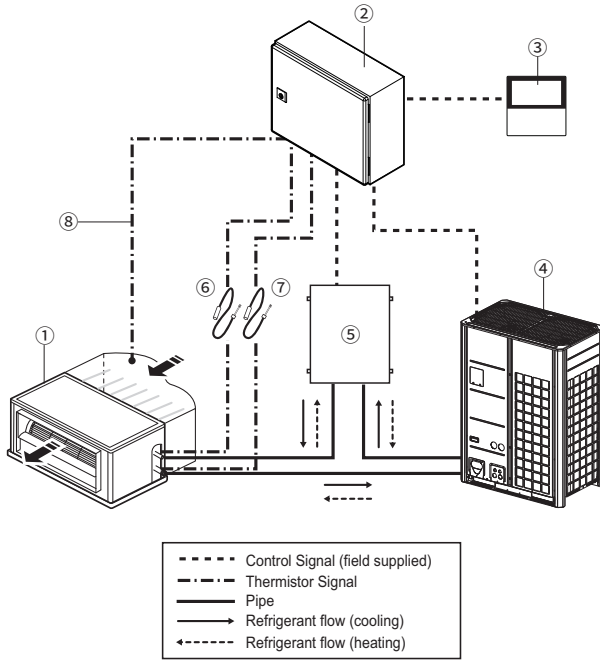

No.	Item	Specification
①	AHU(Air Handling Unit)	Local supply
②	AHU Communication kit	PAHCMS000/PAHCMR000
③	Remote controller	LG wired remote controller(Optional)
④	Outdoor unit	MULTI V
⑤	EEV Kit	PRLK048A0/PRLK096A0/PRLK396A0/PRLK594A0
⑥	Pipe in(Liquid) thermistor	Sensor : Ø 5(NTC 5 kΩ) length : 5 m, Cable color : Black
⑦	Pipe out(Gas) thermistor	Sensor : Ø 7(NTC 5 kΩ) length : 5 m, Cable color : Red
⑧	Room(Return) thermistor	Sensor : NTC 10 kΩ length : 5 m, Cable color : Black

# TECHNICAL SPECIFICATION

## 1. COMMUNICATION KIT

Model			PAHCMR000	PAHCMS000
Application			Return air temperature control	Discharge(supply) air temperature control
Dimensions	Width	mm	300	380
	Depth	mm	155	155
	Height	mm	300	300
Net Weight		kg	6.2	7.46
Casing	Color		RAL 7035	RAL 7035
	Material		Steel	Steel
	Certification Degree of Protection		IP 66 (EN 60529)	IP 66 (EN 60529)
			UL 508 Type 4 / NEMA 4	UL 508 Type 4 / NEMA 4
		IK 08 (EN 50102)	IK 08 (EN 50102)	
Power Supply	Voltage	V	220-240	220-240
	Frequency	Hz	50/60	50/60
	Phase	Ø	1	1
Current	Rated	A	0.1	0.1
Composition	Controller		Communication Module : 1 EA	Main Module : 1 EA Communication Module : 1 EA
	Terminal Block	Power Supply	Screw type (L / N, Ring type)	Screw type (L / N, Ring type)
		Communication	Spring push type (Pin type, JOBN153)	Spring push type (Pin type, JOBN153)
	Temp. Sensor	Air (Room)	Q'ty : 1 EA (Pin type, 5m, Black)	Q'ty : 1 EA (Pin type, 5m, Black)
	Key		EA	1
	Installation Manual		EA	1
Product Environment Operation Range	Ambient Temperature		- 20 ~ 65 °C DB	- 20 ~ 65 °C DB
	Humidity		0 ~ 98 %	0 ~ 98 %

## 2. CONTROLLER MODULE

Model			PAHCM000	PAHCMC000
Application			Main module	Communication module
Dimensions	Width	mm	162	108
	Depth	mm	61	61
	Height	mm	90	90
Power Supply	Voltage	V	DC 12 V	DC 12 V
Product Environment Operation Range	Ambient Temperature		- 20 ~ 65 °C DB	- 20 ~ 65 °C DB
	Humidity		0 ~ 98 %	0 ~ 98 %

### NOTE

- Maximum connectable PAHCMR000(Communication Module) to Discharge air temperature control(PAHCMS000) AHU Communication Kit is less or equal than 3, i.e. 'PAHCMS000 x 1 + PAHCMR000 x 3 system' can control 4 circuits of the DX coil.

# CONTROLLER MODULE

Unit(mm)

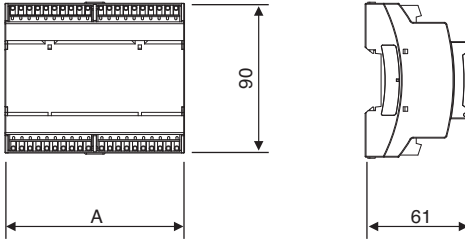

Model	Size (mm)	Remark
	A	
PAHCMM000 <sup>1)</sup>	162	Main module
PAHCMC000 <sup>2)</sup>	108	Communication module

1) PAHCMM000 Model refer for Main module.

2) PAHCMC000 Model refer for Communication module.

## ⚠ CAUTION

- This model requires DC12 V ~ external power supply. (Select an insulating transformer that complies with IEC61558-2-6 and NEC Class 2.)
- Please check the Product operation range below.
- The Ingress Protection Marking given in this manual as IP20 restricts installation location, LG Electronics is not responsible for installation locations non-compliant to IP20.

Power supply		DC 12 V
Product operation range	Ambient Temperature	-20 ~ 65 °C DB
	Humidity	0 ~ 98 %

# COMMUNICATION KIT

## Mechanical installation

- 1 Open the door using the key.

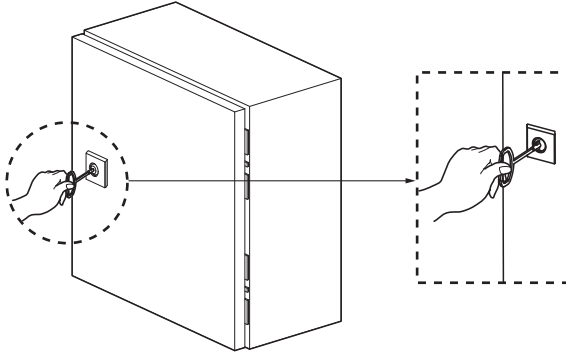

- 2 Drill 4 holes on correct position and fix the Communication Kit box securely with 4 screws (Field supply) through the holes  $\varnothing 9$  mm (11/32 inch).

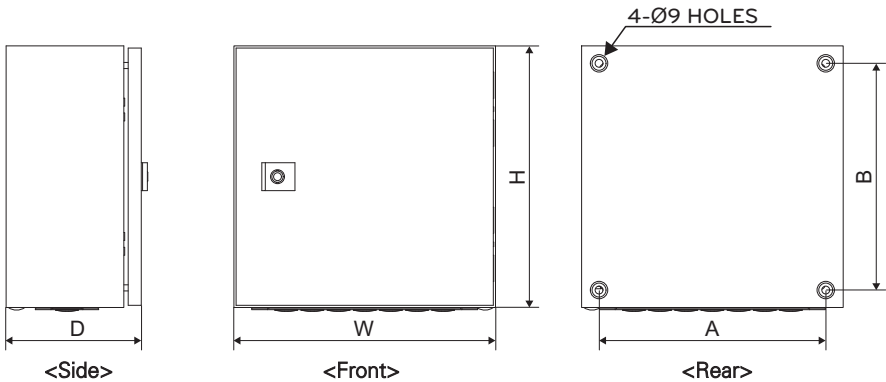

Model	Size (mm)				
	W	D	H	A	B
PAHCMR000	300	155	300	260	260
PAHCMS000	380	155	300	340	260

### Connection of the wires

- 1 For connection to outdoor unit and to controller (Field supply) :  
Pull the wires inside through the cable gland and close the nut firmly in order to ensure a good pull relieve and water protection.
- 2 The wires require an additional pull-relief. Strap the wire with the support tie wrap.

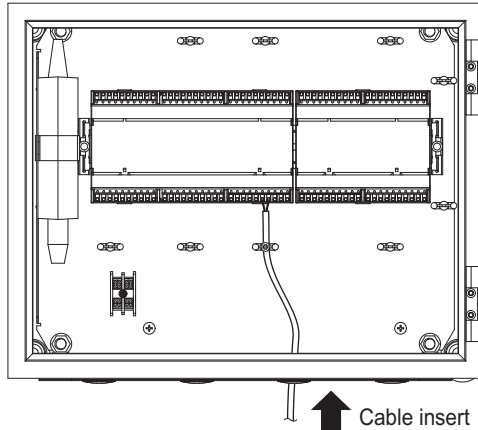

- 3 For the wired remote controller wire and outdoor unit communication wire, use the Pin type (JOBN153) to connect to the terminal block.

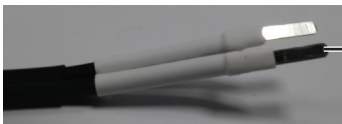

### ! CAUTION

- All field supplied parts and materials and electric works must be conform to local codes.
- Use copper wire only.
- All wiring must be performed by an authorized electrician.
- A main switch or other means for disconnection, having a contact separation in all poles, must be incorporated in the fixed wiring in accordance to relevant local and national legislation.
- Refer to the installation manual attached to the outdoor unit for the size of power supply electric wire connected to the outdoor unit, the capacity of the circuit breaker and switch, wiring and wiring instructions.

# THERMISTORS INSTALLATION

## Pipe thermistors Installation

### Location of the pipe thermistors

A correct installation of the thermistors is required to ensure a good operation :

- 1 Pipe\_In  
: Install the thermistor behind the distributor on the coldest pass the heat exchanger (contact your heat exchanger dealer).
- 2 Pipe\_Out  
: Install the thermistor at the outlet of the heat exchanger as close as possible to the heat exchanger.

Evaluation must be done to check if the evaporator is protected against freeze-up. Execute test operation and check for freeze up.

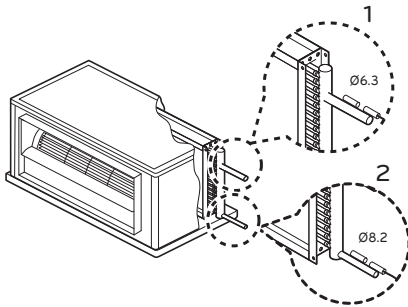

(Air handling unit)

## INSTRUCTION

- To prevent condensation from accumulating on the bottom of the pipe sensor, install the sensor by lifting it up as shown below.

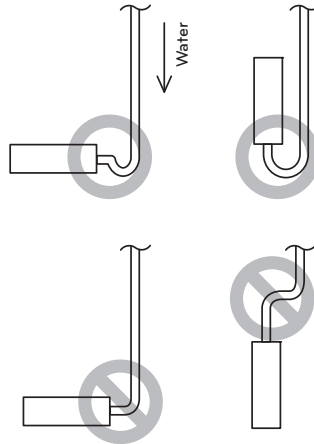

- In order to detect the temperature of the pipe well, install the sensing part so that it can be attached to the pipe well as shown below.

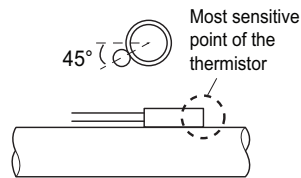

# RETURN AIR TEMPERATURE CONTROL (PAHCMR00)

## DIP SW

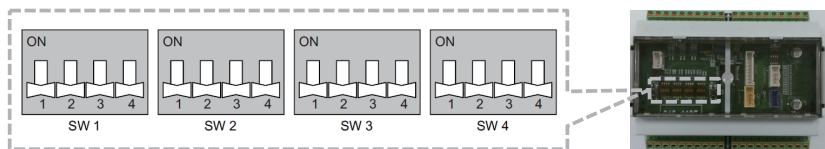

The default setting of all DIP switch is set "off"

<Communication Module>

■ Table of SW1~SW3

SW name	No	Item	Setting		Note
SW1	1	ODU Type	ON	Single Comm.	Using Single Split outdoor unit
			OFF	MULTI V Comm.	Using MULTI V outdoor unit
	2	Control Type	ON	Communication	Controlled by DDC Modbus or LG remote controllers & central controllers
			OFF	Contact signal	Controlled by DDC through Contact signal (LG Central controller can only monitor status)
	3	DO Type	ON	Fan Speed	DO1 : High, DO2 : Middle, DO3 : Low (DO changes according to fan speed setting value)
			OFF	Status	DO1 : ON/OFF, DO2 : Defrost, DO3 : Alarm
	4	Fan Speed (available when SW1-3 'ON')	ON	Fixed	The fan will always be running as set fan speed except defrost. (During defrost, the fan speed will change as low fan speed.)
			OFF	Change	The fan speed will be changed according to TH on/off For more detail please check 'Digital Output – Fan Speed'
SW2	1	Room thermistor sensor reference setting	ON	Remote control / Indoor unit / 2TH	Control according to value of remote control installer setting no.4 (refer to the remote control manual)
			OFF	Indoor unit	-
	2	Reserved	-	-	-
	3/4	UI Setting	OFF/OFF	UI Setting #1	UI1 : Operation ON/OFF, UI2 : Heating/Cooling UI3 : Forced Thermal ON/OFF <sup>1)</sup> UI4 : Target air temperature <sup>2)</sup>
			OFF/ON	UI Setting #2	UI1 : Operation ON/OFF, UI2 : Cooling only/OFF UI3 : Heating only/OFF, UI4 : Forced Thermal ON/OFF
			ON/OFF	UI Setting #3	UI1: Operation On/Off, UI2: Heating/Cooling UI3/UI4 : Thermal on/off with fan speed
			ON/ON	UI Setting #4	UI1 : Operation On/Off, UI2 : Heating/Cooling UI3 : Emergency Stop

<sup>1)</sup> It change to Target air temperature when SW\_FLASH is set AHU Comm. Kit (R32)

















<sup>2)</sup> It change to refrigerant leak detection sensor contact signal when SW\_FLASH is set AHU Comm. Kit (R32)

SW name	No	Item	Setting		Note
SW3	1	Group Master/Slave (Return Air only)	ON	Slave mode	Please see "Multiple module installation guide In the PDB" for more detail
			OFF	Master mode	Master mode is default for single AHU Controller installation. Please see "Multiple module installation guide In the PDB" for more detail
	2/3	Operation mode setting	OFF/OFF	Heat Pump	Cooling or Heating operation mode is available
			OFF/ON	Heating Only	Operation mode is Heating only (Heating / Fan)
			ON/OFF	Cooling Only	Operation mode is Cooling only (Cooling / Fan)
		ON/ON	Reserved	-	
4	Reserved	-	-	-	
SW4	1~4	Capacity Index Setting	-	-	According to ODU Type, you can setup the capacity index of MULTI V or Single Split

**NOTE**

- Do not change the reserved switch(It may malfunction).
- To use the group control, length of group control cable is max 50 m.

■ Table of SW4 (Capacity Index Setting)

No	SW4 DIP switch	Capacity [kBTU/hr]		Capacity [kW]	
		MULTI V	Single	MULTI V	Single
1		12	5	3.5	1.5
2		15	7	4.5	2.1
3		18	9	5.6	2.5
4		24	12	7.1	3.5
5		28	15	8.2	4.2
6		36	18	10.6	5.0
7		42	24	12.3	7.1
8		48	30	14.1	8.0
9		54	36	15.8	10.0
10		76	42	22.4	12.5
11		96	48	28.0	14.0
12		115	60	33.6	15.0
13		134	70	39.2	19.0
14		153	85	44.8	23.0
15		172	Reserved	50.4	Reserved
16		192	Reserved	56.0	Reserved

**NOTE**

If connecting expansion valve's capacity is bigger than 192 kBTU/h, set DIP switches 1, 2, 3, and 4 to ON.

Electric Wiring Work (PAHCMR000)

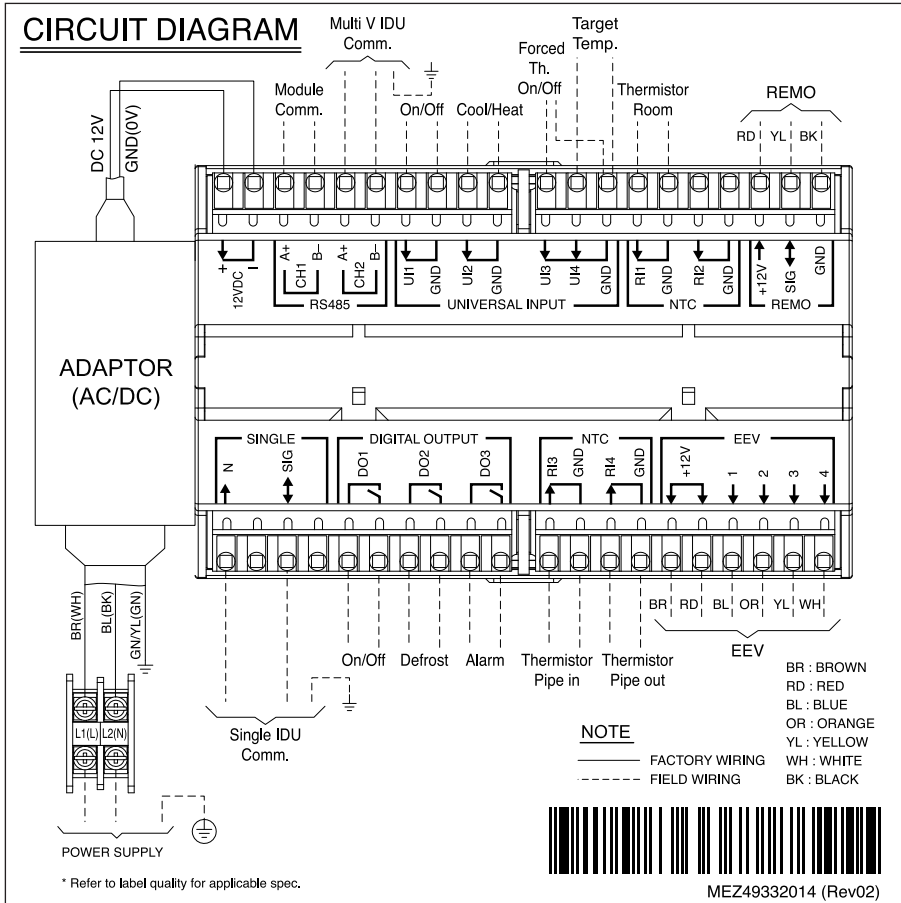

**Electric specification of port****■ RS485/SINGLE Communication port**

Name	Port	Contents	Electrical Spec.	Function
Module Comm.	RS485 CH1	DDC(Modbus) Comm.	Max 500 m, 2C x (1.0~1.5) mm <sup>2</sup> (shield wire)	Communication with DDC or Main module of PAHCMS000 model through Modbus protocol
MULTI V IDU Comm.	RS485 CH2	MULTI V IDU Comm.	Max 1 km, 2C x (1.0~1.5) mm <sup>2</sup> (shield wire)	Communication with MULTI V Outdoor unit
Single IDU Comm.	SINGLE N/SIG	Single IDU Comm.	Max 75 m, 2C x (1.0~1.5) mm <sup>2</sup> (shield wire)	Communication with Single Split Outdoor unit

**■ NTC Thermistor**

Name	Port	Contents	Electrical Spec.	Function
Thermistor Room	NTC RI1/G	Room (Return) air thermistor	NTC 10 k $\Omega$ , 5 m	Return air temperature sensor
Thermistor Pipe in	NTC RI3/G	Pipe in (Liquid) thermistor	NTC 5 k $\Omega$ , 5 m	Inlet pipe (Liquid) Temp. sensor
Thermistor Pipe out	NTC RI4/G	Pipe out (Gas) thermistor	NTC 5 k $\Omega$ , 5 m	Outlet pipe (Gas) Temp. sensor

■ Universal Input – UI Setting #1

‘UI setting #1’ is available when DIP SW1-2 is OFF and both of DIP SW 2-3 and SW 2-4 are OFF



Note : DIP SW 1-2 is for contact signal control

Name	Port	Value		Electrical Spec.	Function									
		Short	Open											
ON / OFF	UI1 (DI)	ON	OFF	Non voltage	ON/OFF operation control									
Cool / Heat	UI2 (DI)	Heating	Cooling	Non voltage	Heating/Cooling Operation Control if operation mode (DIP SW 3-2, 3-3) is set to cooling only mode, UI2 "Short" status will work as fan mode. if operation mode (DIP SW 3-2, 3-3) is set to heating only mode, UI2 "Open" status will work as fan mode.									
Forced Thermal ON / OFF	UI3 (DI)	Thermal ON	Thermal OFF	Non voltage	When UI3(Target temp.) is less than 1.5 V, Target temp. and Room temp. is fixed like below table									
					<table border="1"> <thead> <tr> <th>Mode \ UI3 status</th> <th>Cooling mode</th> <th>Heating mode</th> </tr> </thead> <tbody> <tr> <td>Thermal ON</td> <td>Target temp. = 16 °C Room temp. = 30 °C</td> <td>Target temp. = 30 °C Room temp. = 16 °C</td> </tr> <tr> <td>Thermal OFF</td> <td>Target temp. = 30 °C Room temp. = 16 °C</td> <td>Target temp. = 16 °C Room temp. = 30 °C</td> </tr> </tbody> </table>	Mode \ UI3 status	Cooling mode	Heating mode	Thermal ON	Target temp. = 16 °C Room temp. = 30 °C	Target temp. = 30 °C Room temp. = 16 °C	Thermal OFF	Target temp. = 30 °C Room temp. = 16 °C	Target temp. = 16 °C Room temp. = 30 °C
					Mode \ UI3 status	Cooling mode	Heating mode							
Thermal ON	Target temp. = 16 °C Room temp. = 30 °C	Target temp. = 30 °C Room temp. = 16 °C												
Thermal OFF	Target temp. = 30 °C Room temp. = 16 °C	Target temp. = 16 °C Room temp. = 30 °C												
Target Temp.	UI4 (AI)	Voltage (V)	Electrical Spec.	Cooling Mode [°C]	Heating Mode [°C]									
		1.5	DC 0~10 V, 20 mA	UI3 short : 16 °C, UI3 open : 30 °C	UI3 short : 30 °C, UI3 open : 16 °C									
		2.0		16	16									
		2.5		17	17									
		3.0		18	18									
		3.5		19	19									
		4.0		20	20									
		4.5		21	21									
		5.0		22	22									
		5.5		23	23									
		6.0		24	24									
		6.5		25	25									
		7.0		26	26									
		7.5		27	27									
		8.0		28	28									
8.5	29	29												
9.0 ≤	30	30												

**NOTE**

Maintain previous value when getting intermediate value to UI4

### ■ Universal Input – UI Setting #2

'UI setting #2' is available when DIP SW1-2 is OFF, DIP SW 2-3 is OFF and SW 2-4 is ON.

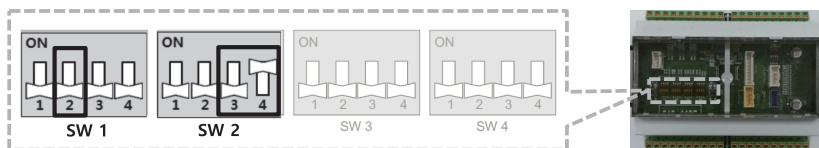

Note : DIP SW 1-2 is for contact signal control.

Name	Port	Value		Electrical Spec.	Function		
		Short	Open				
ON / OFF	UI1 (DI)	ON	OFF	Non voltage	ON/OFF operation control		
Forced Th. ON / OFF	UI4 (DI)	Thermal ON	Thermal OFF	Non voltage	Mode \ UI 4 status	Cooling mode	Heating mode
					Thermal ON	Target Temp. = 16 °C Room Temp. = 30 °C	Target Temp. = 30 °C Room Temp. = 16 °C
					Thermal OFF	Target Temp. = 30 °C Room Temp. = 16 °C	Target Temp. = 16 °C Room Temp. = 30 °C

### Operation Mode Setting

Mode	Status		Electrical Spec.	Function
	UI2	UI3		
Cooling	Short	Open	Non voltage	Cooling mode operation control
Heating	Open	Short	Non voltage	Heating mode operation control
Fan	Open	Open	Non voltage	Fan mode operation control
	Short	Short	Non voltage	

■ Universal Input – UI Setting #3

'UI setting #3' is available when DIP SW1-2 is OFF, DIP SW 2-3 is ON and SW 2-4 is OFF.



Note : DIP SW 1-2 is for contact signal control

Name	Port	Value		Electrical Spec.	Function
		Short	Open		
ON / OFF	UI1 (DI)	ON	OFF	Non voltage	ON/OFF operation control
Cool / Heat	UI2 (DI)	Heating	Cooling	Non voltage	Heating/Cooling Operation Control. If operation mode (DIP SW 3-2, 3-3) is not set to cooling only mode, UI2 "Heating" status will work as heating mode, otherwise it will work as cooling mode. If operation mode (DIP SW 3-2, 3-3) is not set to heating only mode, UI2 "Cooling" status will work as cooling mode, otherwise it will work as heating mode.
Thermal ON/OFF with Fan Speed	UI3, UI4(DI)	-	-	Non voltage	Air Volume Settings 00: Th. OFF Low, 01: Th. ON Low 10: Th. ON Middle, 11: Th. ON High

Forced Th. ON/OFF with Fan Speed Setting

Mode	Status		Electrical Spec.	Function	
	UI3	UI4		Cooling mode	Heating mode
Forced Th. ON/OFF with Fan Speed	Open	Open	Non voltage	Target Temp. = 30 °C Room Temp. = 16 °C Fan Speed Low	Target Temp. = 16 °C Room Temp. = 30 °C Fan Speed Off
	Open	Short	Non voltage	Target Temp. = 16 °C Room Temp. = 30 °C Fan Speed Low	Target Temp. = 30 °C Room Temp. = 16 °C Fan Speed Low
	Short	Open	Non voltage	Target Temp. = 16 °C Room Temp. = 30 °C Fan Speed Middle	Target Temp. = 30 °C Room Temp. = 16 °C Fan Speed Middle
	Short	Short	Non voltage	Target Temp. = 16 °C Room Temp. = 30 °C Fan Speed High	Target Temp. = 30 °C Room Temp. = 16 °C Fan Speed High

### ■ Universal Input – UI Setting #4

'UI setting #4' is available when DIP SW1-2 is OFF, DIP SW 2-3 is ON and SW 2-4 is ON.

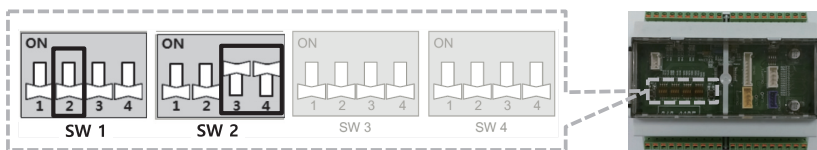

Note : DIP SW 1-2 is for contact signal control

Name	Port	Value		Electrical Spec.	Function
		Short	Open		
ON / OFF	UI1 (DI)	ON	OFF	Non voltage	ON/OFF operation control
Cool / Heat	UI2 (DI)	Heating	Cooling	Non voltage	Heating/Cooling Operation Control. If operation mode (DIP SW 3-2, 3-3) is not set to cooling only mode, UI2 "Heating" status will work as heating mode, otherwise it will work as cooling mode. If operation mode (DIP SW 3-2, 3-3) is not set to heating only mode, UI2 "Cooling" status will work as cooling mode, otherwise it will work as heating mode.
Emergency Stop	UI3 (DI)	ON	OFF	Non voltage	Emergency Stop

## DIP SW\_FLASH

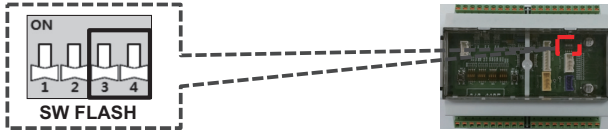

The default setting of all DIP switch is set "off".

■ Table of DIP SW\_FLASH

SW name	No	Item	Setting	Note
SW_FLASH	1	-	-	Onboarding Port
	2	-	-	Onboarding Port
	3,4	Refrigerant leakage detecting	OFF/OFF	AHU Comm. Kit (R410A)
			OFF/ON	AHU Comm. Kit (R410A)
			ON/OFF	AHU Comm. Kit (R32) UI1: Operation ON/OFF UI2: Cooling/Heating UI3: Thermal ON/OFF UI4: 3 <sup>rd</sup> Party refrigerant sensor
			ON/ON	AHU Comm. Kit (R32) UI1: Operation ON/OFF UI2: Cooling/Heating UI3: Target air temperature UI4: 3 <sup>rd</sup> Party refrigerant sensor

**NOTE**

Do not change the reserved switch(It may malfunction).

■ Digital Output – Status

‘Status Output’ is available when DIP SW1-3 is OFF.



Name	Port	Value		Electrical Spec.	Function
		Short	Open		
ON / OFF	DO1	ON	OFF	250 V AC / 1 A 30 V DC / 1 A	Operation ON/OFF Status
Defrost	DO2	Defrost	Normal		ODU Defrost Status (Only total defrost mode)
Alarm	DO3	Error	Normal		Error output status

■ Digital Output – Fan Speed (Fixed)

‘Fan Speed Output (Fixed)’ is available when DIP SW1-3 is ON and DIPSW1-4 is ON.

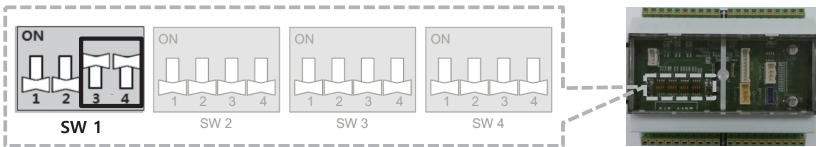

Name	Port	Value		Electrical Spec.	Function
		Short	Open		
Fan_High	DO1	High	Operation OFF	250 V AC / 1 A 30 V DC / 1 A	The fan will always be running as set fan speed except defrost. During defrost, the fan speed will change as low fan speed.
Fan_Mid	DO2	Mid			
Fan_Low	DO3	Low			

## ■ Digital Output – Fan Speed (Change)

'Fan Speed Output (Change)' is available when DIP SW1-3 is ON and DIP SW1-4 is OFF.



### • Cooling or Heating – TH ON

Name	Port	Value		Electrical Spec.	Function
		Short	Open		
Fan_High	DO1	High	-	250 V AC / 1 A 30 V DC / 1 A	DO ports output fan speed signal according to setting value
Fan_Mid	DO2	Mid			
Fan_Low	DO3	Low			

### • Cooling – TH OFF

Name	Port	Value		Electrical Spec.	Function
		Short	Open		
Fan_High	DO1	-	TH OFF	250 V AC / 1 A 30 V DC / 1 A	DO 1,2 is 'Open', DO 3(Low) is 'short'.
Fan_Mid	DO2	-	TH OFF		
Fan_Low	DO3	TH OFF	-		

### • Heating – TH OFF or defrost

Name	Port	Value		Electrical Spec.	Function
		Short	Open		
Fan_High	DO1	-	TH OFF	250 V AC / 1 A 30 V DC / 1 A	1) During defrost, All DOs are 'Open'. 2) The fan speed will be changed according to TH on/off. <b>In cooling mode,</b> - The fan speed will be running as low fan during TH off. - The fan speed will be running as set fan speed during TH on. <b>In heating mode,</b> - The fan speed will be stopped during TH off temperature setting. - The fan will be running for 20 s during TH OFF. - The fan speed will be running as set fan speed during TH on with pipe temp.
Fan_Mid	DO2	-	TH OFF		
Fan_Low	DO3	-	TH OFF		

### ■ Remote Controller

Name	Port	Item	Electrical Spec.	Function
REMO	+12 V SIG/GND	Wired Remote Controller	Max 50 m	Communication with Wired Remote Controller

### ■ EEV

Name	Port	Item	Electrical Spec.	Function
EEV	12 V DC/1/2/3/4	EEV Control	Max 5 m	EEV Control

### ■ LED Display

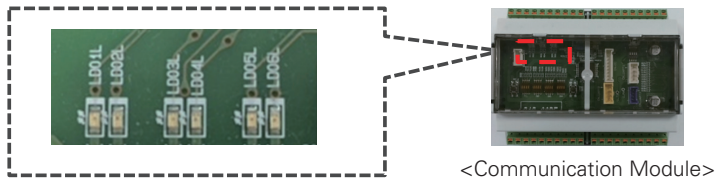

Name	Port	Function
LD01L	LED1	Modbus Comm. Tx
LD02L	LED2	Modbus Comm. Rx
LD03L	LED3	Inner Comm. Tx
LD04L	LED4	Inner Comm. Rx
LD05L	LED5	ODU Comm. (Repeat ON/OFF when communicating with ODU)
LD06L	LED6	Error Status (Repeat ON/OFF when error occurs)

# DISCHARGE AIR TEMPERATURE CONTROL (PAHCMS000)

## Main Module DIP SW

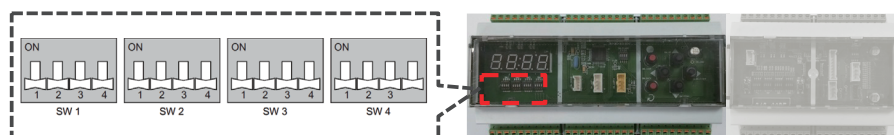

The default setting of all DIP switch is set "off"

<Main Module>

<Communication Module>

■ Table of SW1~SW4

SW name	No	Item	Setting		Note
SW1	1	Control Type	ON	Communication	Controlled by DDC through Modbus or LG central controller
			OFF	Contact signal	Controlled by DDC through Contact signal LG Central controller can only monitor status
	2	Discharge Temp. Control Type	ON	Stand alone	LG remote controllers & central controllers or DDC(Modbus) can control discharge air temperature by using LG discharge temperature sensor
			OFF	Manual by DDC	DDC(Contact Signal or Modbus) can control discharge air temperature by ODU capacity control referring to field supplied discharge temperature
	3	Defrost Operation Type <sup>1)</sup>	ON	Normal	In case of multiple outdoor units, Defrost operation can be operated simultaneously
			OFF	Sequential Start up	In case of multiple outdoor units, the outdoor unit is sequentially started at intervals of 10 minutes
	4	LG Central Communication Type (CH3 of Main Module)	ON	Modbus	Modbus communication between main module and LG central controller (control/monitoring possible)
			OFF	LGAP AHU	LGAP AHU communication between main module and LG central controller (monitoring only)
SW2	1	ODU Capacity Control	ON	ODU Capacity Setting #2	ODU capacity control #2
			OFF	ODU Capacity Setting #1	ODU capacity control #1
	2	Reserved	-	-	-
	3	Reserved	-	-	-
SW3	1	Reserved	-	-	-
	2	Reserved	-	-	-
	3	Reserved	-	-	-
	4	Reserved	-	-	-
SW4	1	Emergency Stop <sup>2)</sup>	ON	Setting #2	System stops when the circuit(DI3-GND) is 'open'
			OFF	Setting #1	System stops when the circuit(DI3-GND) is 'short'
	3	Reserved	-	-	-
	4	Reserved	-	-	-

### NOTE

- Function of defrost operation type can be applied only to MULTI V outdoor units.
- Emergency Stop function is working regardless 'Control Type' setting (DIP Switch SW1-2)

### Communication Module DIP SW

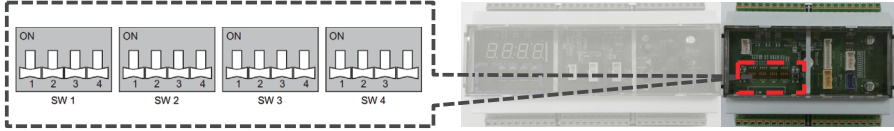

The default setting of all DIP switch is set "off".

<Main Module>

<Communication Module>

■ Table of SW1~SW3

SW name	No	Item	Setting		Note
SW1	1	ODU Type	ON	Single Comm.	Using Single Split outdoor unit
			OFF	MULTI V Comm.	Using MULTI V outdoor unit
	2	Control Type	ON	Communication	Controlled by DDC Modbus or LG remote controllers & central controllers (It must be 'ON', when comm. module is connected with Main Module.)
			OFF	Contact signal	Not used
	3	DO Type	ON	Fan Speed	Not used
			OFF	Status	Not used
	4	Fan Speed (TH. ON/OFF)	ON	Fixed	Not used
			OFF	Change	Not used
SW2	1	Reserved	-	-	-
	2	Reserved	-	-	-
	3/4	UI Setting	OFF/OFF	UI Setting #1	Not used
			OFF/ON	UI Setting #2	Not used
			ON/OFF	-	-
ON/ON			-	-	
SW3	1	Master/Slave	ON	Slave mode	Not used
			OFF	Master mode	Master is default
	2/3	Operation mode setting	OFF/OFF	Heat Pump	Cooling or Heating operation mode is available.
			OFF/ON	Heating Only	Operation mode is Heating only (Heating/Fan).
			ON/OFF	Cooling Only	Operation mode is Cooling only (Cooling/Fan).
			ON/ON	Reserved	-
	4	Reserved	-	-	-
	SW4	1~4	Capacity Index Setting	-	-

**NOTE**

Do not change the reserved switch(It may malfunction).



**CAUTION**

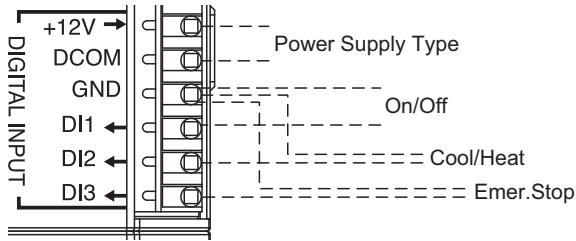

Please check the electrical specification of digital output (DO) of DDC whether 12 V DC or Non-voltage for 'DI Control'.

According to the power supply type of DO, please make wirings as below.

**Internal Power Source (Non-Voltage)**

**External Power Source (12 V DC)**

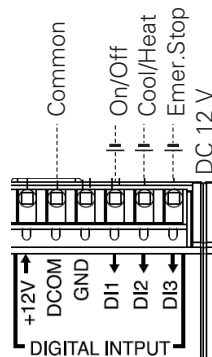
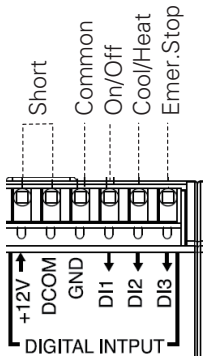

For detail wiring, please see "Digital Input - Internal power source", and Digital Input - External Power Source (12 V DC)" in the PDB.

## Main Module \_ Electric specification of port

## ■ RS485 Communication port

Name	Port	Item	Electrical Spec.	Function
ODU Comm.	RS485 CH2	ODU Comm. (CEN A/B or INT A/B)	Max 1km, 2C x (1.0~1.5) mm <sup>2</sup> (shield wire)	Communication with MULTI V/Single split ODU for ODU Capacity control
LG Central Comm.	RS485 CH3	LG Central Comm.	Max 500 m, 2C x (1.0~1.5) mm <sup>2</sup> (shield wire)	Communication with LG central controller through LGAP AHU Protocol
DDC Central Comm.	RS485 CH4	DDC(Modbus) Central Comm.	Max 500 m, 2C x (1.0~1.5) mm <sup>2</sup> (shield wire)	Communication with DDC central controller through Modbus protocol

## ■ Universal Input

Digital Input

\*UI is available when DIP SW1-1 is OFF.

Name	Port	Value		Electrical Spec.	Function
		Short	Open		
Fan_Low	UI4	Low	STOP	Non voltage	Fan Speed Setting Input
Fan_Mid	UI5	Mid	STOP	Non voltage	
Fan_High	UI6	High	STOP	Non voltage	

Analog Input

Name	Port	Value	Electrical Spec.	Function
Capacity Control 0 ~ 10 V	UI7 (AI)	0 ~ 10 V Input	DC 0 ~ 10 V, 20 mA	ODU Capacity control input (0 ~ 10V) * When Temp. Control Type is 'Manual by DDC' (SW 1-2 : OFF), below UI7 Table setting is available.

**NOTE**

Please refer to the 'UI7(Analog Input) – ODU Capacity Control' of this manual.

**Digital Input - Internal Power Source (Non-voltage)**

\*DI is available when DIP SW1-1 is OFF

Name	Port	Value		Electrical Spec.	Function
		Short	Open		
ON/OFF	DI1 - GND	ON	OFF	Non voltage	Operation ON/OFF
Cool/Heat	DI2 - GND	Heating	Cooling	Non voltage	Operation Mode
Emer. Stop	DI3 - GND	Emergency Stop	Normal	Non voltage	Emergency Stop Input (Priority operation)
DI Control	+12 V-DCOM	Internal Power Source	External Power Source	Non voltage	Use internal power source for DI +12 V-DCOM should be "Short".

**Digital Input - External Power Source (12 V DC)**

\*DI is available when DIP SW1-1 is OFF

Name	Port	Value		Electrical Spec.	Function
		Short	Open		
ON/OFF	DI1 - DCOM	ON	OFF	12 V DC 10 mA	Operation ON/OFF
Cool/Heat	DI2 - DCOM	Heating	Cooling	12 V DC 10 mA	Operation Mode
Emer. Stop	DI3 - DCOM	Emergency Stop	Normal	12 V DC 10 mA	Emergency Stop Input (Priority operation)
DI Control	+12 V-DCOM	Internal Power Source	External Power Source	Non voltage	Use external power source for DI +12 V-DCOM should be "Open"

**CAUTION**

Please check the electrical specification of digital output (DO) of DDC controller whether 12 V DC or non-voltage for 'DI Control'. According to the electrical spec. of DO of DDC controller, 'DI Control' should be set. If the wrong setting is made, DI does not work properly.

### ■ Digital Output (Relay C contact)

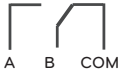
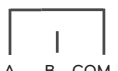
Name	Port	Value	Electrical Spec.	Function
Alarm	DO1	- Normal Status  A B COM - Error Status  A B COM	30 V DC / 1 A 250 V AC / 1 A	Output normal or error status (Relay C Contact) - A Contact Normal status : open Error status : short - B Contact Normal status : short Error status : open

### ■ Digital Output

Name	Port	Value		Electrical Spec.	Function
		Short	Open		
ON/OFF	DO2	ON	OFF	250 V AC / 1 A 30 V DC / 1 A	Operation ON/OFF status
Defrost	DO3	Defrost	Normal		ODU Defrost status
Comp. Status	DO4	ON	OFF		Compressor operation ON/OFF status
Reserved	DO5	-	-		-
Reserved	DO6	-	-		-

■ UI7(Analog Input) – ODU Capacity Control #1

‘ODU Capacity Control #1’ is available when DIP SW2-1 is OFF, each Master ODU will have a different operating ratio according to following tables.



<Main Module>

<1 System >

Voltage (V)	ODU Capacity Range (%)	Estimated Eva. Temp. (Te,°C)	Estimated Cond. Temp. (Tc,°C)
0.0	Operation OFF	-	-
4.0	40	14.0	33.5
4.5	40	14.0	33.5
5.0	50	12.0	36.5
5.5	50	12.0	36.5
6.0	60	10.5	39.0
6.5	60	10.5	39.0
7.0	70	9.0	41.5
7.5	70	9.0	41.5
8.0	80	8.0	44.0
8.5	80	8.0	44.0
9.0	90	7.0	46.5
9.5	90	7.0	46.5
10.0	100	6.0	49.0

<2 System>

Voltage [V]	Total Capacity ratio [%]	Each ODU's capacity ratio [%]	
		ODU Master#1	ODU Master#2
0	0	Operation OFF	
2.0	20.0	40	0
2.5	25.0	50	0
3.0	30.0	60	0
3.5	35.0	70	0
4.0	40.0	40	40
4.5	45.0	40	50
5.0	50.0	50	50
5.5	55.0	50	60
6.0	60.0	60	60
6.5	65.0	60	70
7.0	70.0	70	70
7.5	75.0	70	80
8.0	80.0	80	80
8.5	85.0	80	90
9.0	90.0	90	90
9.5	95.0	90	100
10.0	100.0	100	100

NOTE

- Based on 7.5 m piping length condition, According to piping length evaporating/condensing temperature will be increasing/decreasing.
- ODU Capacity ratios mentioned in the table above are not exact.
- ‘Evaporative temperature / Condenser temperature’ may vary depending on system operating frequency, pressure option setting and piping installation conditions.
- Single Split ODU is only supporting <1 system> table.

⚠ CAUTION

The actual temperature at the evaporator may vary by pressure drop. Please contact a local sale person to design an AHU heat exchanger.

### ■ UI7(Analog Input) – ODU Capacity Control #1

&lt;3 System&gt;

Voltage [V]	Total Capacity ratio [%]	Each ODU's capacity ratio [%]		
		ODU Master#1	ODU Master#2	ODU Master#3
0	0.0	Operation OFF		
2.0	26.7	40	0	40
2.5	30.0	50	0	40
3.0	33.3	60	0	40
3.5	36.7	70	0	40
4.0	40.0	40	40	40
4.5	46.7	40	50	50
5.0	50.0	50	50	50
5.5	56.7	50	60	60
6.0	60.0	60	60	60
6.5	66.7	60	70	70
7.0	70.0	70	70	70
7.5	76.7	70	80	80
8.0	80.0	80	80	80
8.5	86.7	80	90	90
9.0	90.0	90	90	90
9.5	96.7	90	100	100
10.0	100.0	100	100	100

&lt;4 System&gt;

Voltage [V]	Total Capacity ratio [%]	Each ODU's capacity ratio [%]			
		ODU Master#1	ODU Master#2	ODU Master#3	ODU Master#4
0	0.0	Operation OFF			
2.0	20.0	40	0	40	0
2.5	22.5	50	0	40	0
3.0	25.0	60	0	40	0
3.5	27.5	70	0	40	0
4.0	40.0	40	40	40	40
4.5	47.5	40	50	50	50
5.0	50.0	50	50	50	50
5.5	57.5	50	60	60	60
6.0	60.0	60	60	60	60
6.5	67.5	60	70	70	70
7.0	70.0	70	70	70	70
7.5	77.5	70	80	80	80
8.0	80.0	80	80	80	80
8.5	87.5	80	90	90	90
9.0	90.0	90	90	90	90
9.5	97.5	90	100	100	100
10.0	100.0	100	100	100	100

#### NOTE

- ODU Capacity ratios mentioned in the table above are not exact.
- 'Evaporative temperature / Condenser temperature' may vary depending on system operating frequency, pressure option setting and piping installation conditions.
- Single Split ODU is only supporting <1 system> table.



#### CAUTION

Actual temperature at evaporator may varies by pressure drop. Please contact local sale person to design AHU heat exchanger.

■ UI7(Analog Input) – ODU Capacity Control #2

‘ODU Capacity Control #2’ is available when DIP SW2-1 is ON, each Master ODU will have the same operating ratio according to following tables.

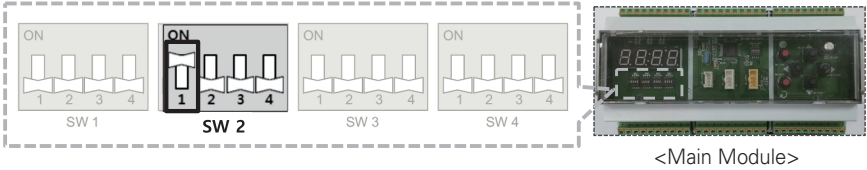

Voltage (V)	ODU Capacity Range (%)	Estimated Eva. Temp. (Te,°C)	Estimated Cond. Temp. (Tc,°C)
0.0	Operation OFF	-	-
1.0	100	6.0	49.0
2.0	90	7.0	46.5
3.0	80	8.0	44.0
4.0	70	9.0	41.5
5.0	60	10.5	39.0
6.0	50	12.0	36.5
7.0	45	13.0	35.3
8.0	40	14.0	33.5
9.0	Operation OFF	-	-
10.0	Operation OFF	-	-

**NOTE**

- Based on 7.5 m piping length condition, According to piping length evaporating/condensing temperature will be increasing/decreasing.
- ODU Capacity ratios mentioned in the table above are not exact.
- ‘Evaporative temperature / Condenser temperature’ may vary depending on system operating frequency, pressure option setting and piping installation conditions.

**CAUTION**

Actual temperature at evaporator may varies by pressure drop. Please contact local sale person to design AHU heat exchanger.

## Communication Module \_ Electric specification of port

## ■ RS485 Communication port

Name	Port	Item	Electrical Spec.	Function
MULTI V IDU Comm.	RS485 CH2	MULTI V Comm. (IDU A/B)	Max 1km, 2C x (1.0~1.5) mm <sup>2</sup> (shield wire)	Communication with MULTI V Outdoor unit
Single IDU Comm.	SINGLE N/SIG	Single split Comm. (IDU A/B)	Max 75 m, 2C x (1.0~1.5) mm <sup>2</sup> (shield wire)	Communication with Single Split Outdoor unit

## ■ NTC Thermistor

Name	Port	Item	Electrical Spec.	Function
Thermistor Discharge	NTC RI2/G	Discharge air Thermistor	NTC 10 k $\Omega$ , 5 m	Discharge Air temperature sensor
Thermistor Pipe in	NTC RI3/G	Pipe in (Liquid) Thermistor	NTC 5 k $\Omega$ , 5 m	Inlet pipe (Liquid) Temp. sensor
Thermistor Pipe out	NTC RI4/G	Pipe out (Gas) Thermistor	NTC 5 k $\Omega$ , 5 m	Outlet pipe (Gas) Temp. sensor

## ■ Remote Controller

Name	Port	Item	Electrical Spec.	Function
REMO	+12 V SIG/GND	Wire Remote Controller	Max 50 m	Communication with Wired Remote Controller

## ■ EEV

Name	Port	Item	Electrical Spec.	Function
EEV	12 V DC/1/2/3/4	EEV Control	Max 5 m	EEV Control

## NOTE

When a communication module (or PAHCMR000) is connected to the main module of PAHCM000, DO and UI in communication module are not used.

## ■ Main Module Address Setting

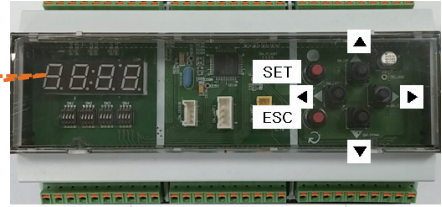

<Main Module>

An address for the main module is needed when PAHCMS000 is connected to LG central controller or DDC by Modbus.

The address of main module can be set within '1~247 in decimal number'. In this case, the address of the main module should be the same as the Modbus address in LG central controller or DDC.

### ◆ Setting Method

- Press 'Set' button(red)
- Select 'Addr' in 7- Segment using ▲ ▼ button and then press 'Set' button
- Press 'ESC' button to exit

## ⚠ CAUTION

Note that LG central controller are using hexadecimal number. Please check the address of main module is matching to the address of LG central controller or DDC when using Modbus protocol. Otherwise, PAHCMS000 will not operate properly.

ex) The address of main module '13' (decimal number)

→ The address of LG central controller should be '0D' (Hexadecimal number).

# EXTERNAL CONNECTION DIAGRAM

## Return air temperature control

Example 1) MULTI V + EEV Kit + LG Control/DDC (Modbus RTU)

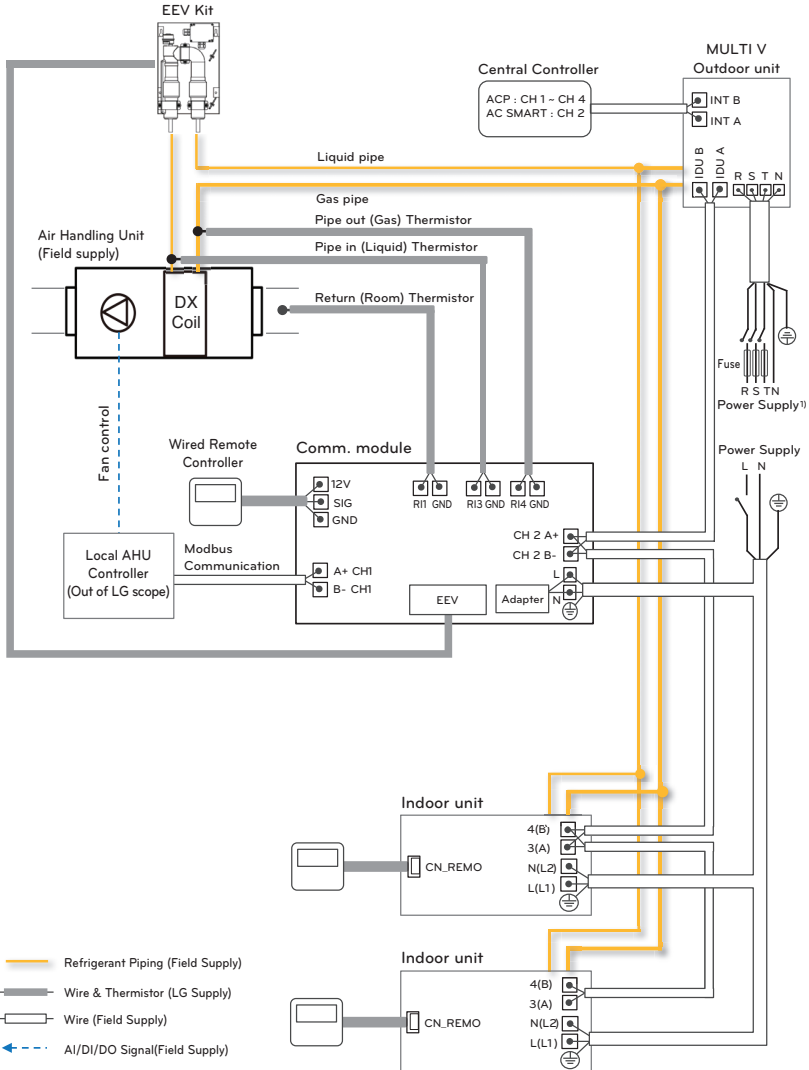

### NOTE

- The type of power supply of outdoor unit can vary depending on the outdoor model.
- Please make wiring between LG controller and outdoor unit with the same polarity.
- LG controller can be optionally applied with DDC.

Example 2) Single Split + LG Control/DDC (Modbus RTU)

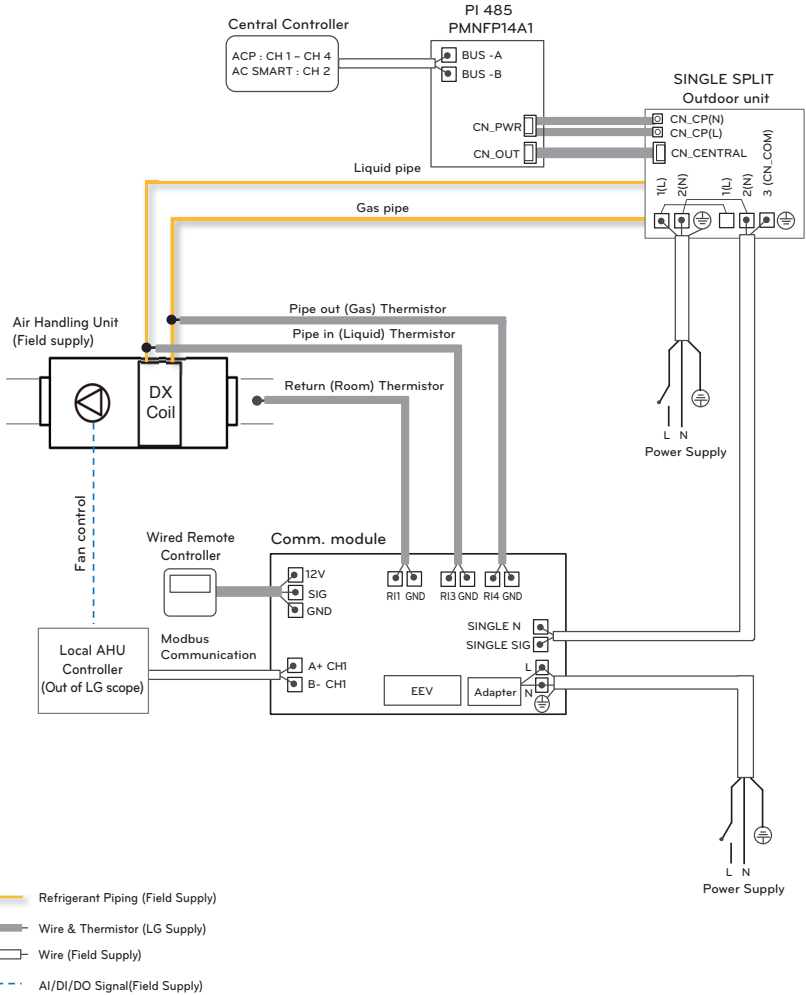

NOTE

- The type of power supply of outdoor unit can vary depending on the outdoor model.
- Please make wiring between LG controller and outdoor unit with the same polarity.
- LG controller can be optionally applied with DDC.

## Discharge air temperature control

### Example 1) MULTI V + EEV + LG Control/DDC (Modbus RTU)

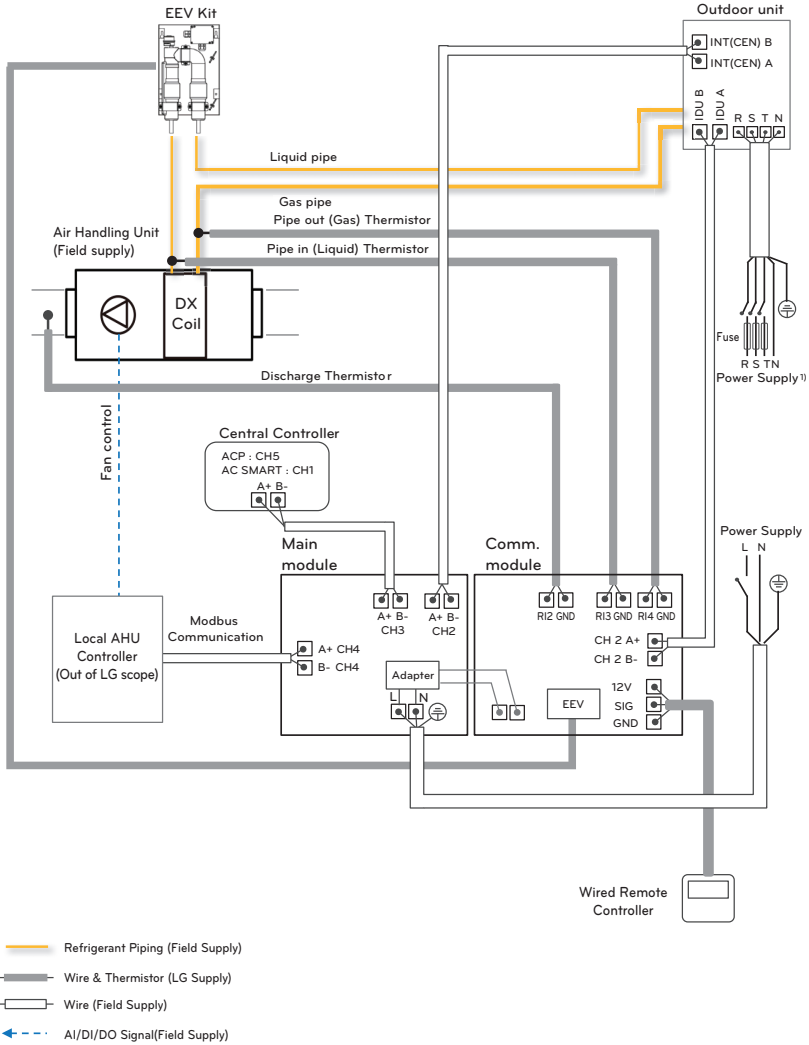

### NOTE

- The type of power supply of outdoor unit can vary depending on the outdoor model.
- Please make wiring between LG controller and outdoor unit with the same polarity.
- LG controller can be optionally applied with DDC.



# BMS PROTOCOL

## BACnet points of PAHCMR000 (Return air temperature control)

### ■ AHU Control / Monitor point

No.	Name	Object Name (XX : Unit Address Number)	Object Type	Unit						
				Inactive TEXT-0	Active					
					TEXT-1	TEXT-2	TEXT-3	TEXT-4	TEXT-5	
1	ON/OFF (Setting)	ac_StartStopCommand_XX	BO	Stop(0)	Start(1)					
2	ON/OFF (Status)	ac_StartStopStatus_XX	BI	Stop(0)	Start(1)					
3	Lock (Setting)	ac_LockCommand_XX	BO	Permit(0)	Prohibit(1)					
4	Lock (Status)	ac_LockStatus_XX	BI	Permit(0)	Prohibit(1)					
5	Operation Mode (Setting)	ac_AirConModeCommand_XX	MO		Cool(1)		Fan(3)		Heat(5)	
6	Operation Mode (Status)	ac_AirConModeStatus_XX	MI		Cool(1)		Fan(3)		Heat(5)	
7	Fan Speed (Setting) <sup>1)</sup>	ac_FanSpeedCommand_XX	MO		Low(1)	Middle(2)	High(3)			
8	Fan Speed (Status) <sup>1)</sup>	ac_FanSpeedStatus_XX	MI		Low(1)	Middle(2)	High(3)			
9	Set Room Temperature	ac_SetRoomTemp_XX	AV	°C(16~30 °C)						
10	Room Temperature	ac_RoomTemp_XX	AI	°C(99-99 °C)						
11	Alarm	ac_Alarm_XX	BI	Normal(0)	Abnormal(1)					
12	Error Code	ac_MalfunctionCode_XX	AI	0~255 (Refer to the LG Error code list)						
13	Set Temperature (Status)	ac_SetTempStatus_XX	AI	°C(16~30 °C)						
14	Set Upper Temperature (Setting)	ac_TempRangeUpperLimitCommand_XX	AV	°C(16~30 °C)						
15	Set Lower Temperature (Setting)	ac_TempRangeLowerLimitCommand_XX	AV	°C(16~30 °C)						
16	Set Upper Temperature (Status)	ac_TempRangeUpperLimitStatus_XX	AI	°C(16~30 °C)						
17	Set Lower Temperature (Status)	ac_TempRangeLowerLimitStatus_XX	AI	°C(16~30 °C)						
18	Mode Lock (Setting)	ac_ModeLockCommand_XX	BO	Permit(0)	Prohibit(1)					
19	Mode Lock (Status)	ac_ModeLockStatus_XX	BI	Permit(0)	Prohibit(1)					
20	Fan Lock (Setting)	ac_FanLockCommand_XX	BO	Permit(0)	Prohibit(1)					
21	Fan Lock (Status)	ac_FanLockStatus_XX	BI	Permit(0)	Prohibit(1)					
22	Thermal Status (Status)	ac_ThermoStatus_XX	BI	OFF(0)	ON(1)					

### NOTE

- ACP BACnet gateway is required for BACnet protocol.
- In case of PAHCMS000, BACnet protocol is not supported.
- For more details, refer to the manual of control product.
  - For fan speed control, it is necessary to set DIP SW 1-3 'ON'.

### ■ Outdoor unit Monitor point

No.	Name	Object Name (XX : Unit Address Number)	Object Type	Unit					
				Inactive	Active				
				TEXT-0	TEXT-1	TEXT-2	TEXT-3	TEXT-4	TEXT-5
1	Compressor Operation Status	outdoor_CompOperStatus_XX	BI	Stop(0)	Run(1)				
2	Inverter Fan 1 frequency	outdoor_InverterFanFreq_XX	AI	-					
3	High Pressure	outdoor_HighPressure_XX	AI	-					
4	Low Pressure	outdoor_LowPressure_XX	AI	-					
5	Suction Temperature	outdoor_SuctionTemp_XX	AI	°C					
6	Liquid Pipe Temperature	outdoor_LiquidPipeTemp_XX	AI	°C					
7	Heat Exchanger Temperature	outdoor_HexTemp_XX	AI	°C					
8	Outdoor EEV	outdoor_OutdoorEEV_XX	AI	-					
9	Subcool EEV	outdoor_SubCoolEEV_XX	AI	-					
10	Hot Gas Valve	outdoor_HotgasValue_XX	BI	Stop(0)	Run(1)				
11	Inverter Discharge Temperature	outdoor_InverterDischargeTemp_XX	AI	°C					
12	Outdoor Temperature	outdoor_OutdoorTemp_XX	AI	°C					
13	Operation Mode	outdoor_OperationMode_XX	MI		STOP(1)	COOL(2)	HEAT(3)		

#### NOTE

- ACP BACnet gateway is required for BACnet protocol.
- In case of PAHCMS000, BACnet protocol is not supported.
- For more details, refer to the manual of control product.



**Modbus points of PAHCMR000 (Return air temperature control)****Function Code**

Code	Description	Register
0x01	Read Coils	00001~00008
0x02	Read Discrete inputs	10001~10008
0x03	Read Holding Registers	40001~40010
0x04	Read Input Registers	30001~30008
0x05	Write Single Coil	00001~00008
0x06	Write Single Holding Register	40001~40010

**Memory Map**

Register	Description	Function Code						Value explanation
		1	2	3	4	5	6	
00001	Operating ON / OFF	●	-	-	-	●	-	0: OFF / 1: ON
00002	Reserved	-	-	-	-	-	-	-
00003	All Button Lock	●	-	-	-	●	-	0: Unlock / 1: Lock
00004	Mode Lock	●	-	-	-	●	-	0: Unlock / 1: Lock
00005	Fan Speed Lock	●	-	-	-	●	-	0: Unlock / 1: Lock
00006	Target Temp. Lock	●	-	-	-	●	-	0: Unlock / 1: Lock
00007	Error	●	-	-	-	-	-	0: Normal / 1: Error
00008	Reserved	-	-	-	-	-	-	-
10001	Comp Status	-	●	-	-	-	-	0: OFF / 1: ON
10002	Defrost Status	-	●	-	-	-	-	0: Normal / 1: Defrost
10003	Oil Return	-	●	-	-	-	-	0: Normal / 1: Oil Return
10004	Reserved	-	-	-	-	-	-	-
10005	Reserved	-	-	-	-	-	-	-
10006	Reserved	-	-	-	-	-	-	-
10007	Reserved	-	-	-	-	-	-	-
10008	Reserved	-	-	-	-	-	-	-
30001	Error Code	-	-	-	●	-	-	0~255
30002	RA Temp.	-	-	-	●	-	-	-50.0 °C~100.0 °C (x10)
30003	Reserved	-	-	-	-	-	-	-
30004	Pipe In Temp.	-	-	-	●	-	-	-50.0 °C~100.0 °C (x10)
30005	Pipe Out Temp.	-	-	-	●	-	-	-50.0 °C~100.0 °C (x10)
30006	Capacity	-	-	-	●	-	-	0~255 [kBtu]
30007	Reserved	-	-	-	-	-	-	-
30008	Reserved	-	-	-	-	-	-	-
40001	Operation Mode	-	-	●	-	-	●	0: Cooling / 2: Fan / 4: Heating
40002	Fan Speed	-	-	●	-	-	●	1: Low / 2: Middle / 3: High
40003	Target Temp.	-	-	●	-	-	●	-10.0 °C~100.0 °C (x10)
40004	Target Temp. Upper Range	-	-	●	-	-	●	16.0 °C~30.0 °C (x10, 1 °C)
40005	Target Temp. Lower Range	-	-	●	-	-	●	16.0 °C~30.0 °C (x10, 1°C)
40006	Reserved	-	-	-	-	-	-	-
40007	Reserved	-	-	-	-	-	-	-
40008	Reserved	-	-	-	-	-	-	-
40009	Reserved	-	-	-	-	-	-	-
40010	Reserved	-	-	-	-	-	-	-

**NOTE**

- Configuration is that the baud rate is 9600bps, parity is none and stop bit is 1.
- To change the slave address, please see Chapter8. Main module Address Setting).

## Modbus points of PAHCMR000 (Return air temperature control)

### Function Code

Code	Description	Register
0x01	Read Coils	00001~00008
0x02	Read Discrete inputs	10001~10030
0x03	Read Holding Registers	40001~40010
0x04	Read Input Registers	30001~30016
0x05	Write Single Coil	00001~00008
0x06	Write Single Holding Register	40001~40028

### Memory Map

Register	Description	Function Code						Value explanation
		1	2	3	4	5	6	
00001	Operating ON / OFF	●	-	-	-	●	-	0: OFF / 1: ON
00002	Reserved	-	-	-	-	-	-	-
00003	Reserved	-	-	-	-	-	-	-
00004	Reserved	-	-	-	-	-	-	-
00005	Reserved	-	-	-	-	-	-	-
00006	Reserved	-	-	-	-	-	-	-
00007	Reserved	-	-	-	-	-	-	-
00008	Reserved	-	-	-	-	-	-	-
10001	Error Status	-	●	-	-	-	-	0: Normal / 1: Error
10002	Operation Status	-	●	-	-	-	-	0: OFF / 1: ON
10003	Defrost Status	-	●	-	-	-	-	0: Normal / 1: Defrost
10004	Reserved	-	-	-	-	-	-	-
10005	Reserved	-	-	-	-	-	-	-
10006	Reserved	-	-	-	-	-	-	-
10007	Reserved	-	-	-	-	-	-	-
10008	Reserved	-	-	-	-	-	-	-
10009	Reserved	-	-	-	-	-	-	-
10010	Reserved	-	-	-	-	-	-	-
10011	ODU#1 Operation Status	-	●	-	-	-	-	0: OFF / 1: ON
10012	ODU#1 Comp. Status	-	●	-	-	-	-	0: OFF / 1: ON
10013	ODU#1 Defrost Status	-	●	-	-	-	-	0: Normal / 1: Defrost
10014	ODU#1 Error Status	-	●	-	-	-	-	0: Normal / 1: Error
10015	ODU#2 Operation Status	-	●	-	-	-	-	0: OFF / 1: ON
10016	ODU#2 Comp. Status	-	●	-	-	-	-	0: OFF / 1: ON
10017	ODU#2 Defrost Status	-	●	-	-	-	-	0: Normal / 1: Defrost
10018	ODU#2 Error Status	-	●	-	-	-	-	0: Normal / 1: Error
10019	ODU#3 Operation Status	-	●	-	-	-	-	0: OFF / 1: ON
10020	ODU#3 Comp. Status	-	●	-	-	-	-	0: OFF / 1: ON
10021	ODU#3 Defrost Status	-	●	-	-	-	-	0: Normal / 1: Defrost
10022	ODU#3 Error Status	-	●	-	-	-	-	0: Normal / 1: Error
10023	ODU#4 Operation Status	-	●	-	-	-	-	0: OFF / 1: ON
10024	ODU#4 Comp. Status	-	●	-	-	-	-	0: OFF / 1: ON
10025	ODU#4 Defrost Status	-	●	-	-	-	-	0: Normal / 1: Defrost
10026	ODU#4 Error Status	-	●	-	-	-	-	0: Normal / 1: Error

## Memory Map

Register	Description	Function Code						Value explanation
		1	2	3	4	5	6	
10027	Reserved	-	-	-	-	-	-	-
10028	Reserved	-	-	-	-	-	-	-
10029	Reserved	-	-	-	-	-	-	-
10030	Reserved	-	-	-	-	-	-	-
30001	Error Code	-	-	-	•	-	-	1xxxx <sup>2)</sup>
30002	Reserved	-	-	-	-	-	-	-
30003	Reserved	-	-	-	-	-	-	-
30004	Reserved	-	-	-	-	-	-	-
30005	Reserved	-	-	-	-	-	-	-
30006	Reserved	-	-	-	-	-	-	-
30007	Reserved	-	-	-	-	-	-	-
30008	Reserved	-	-	-	-	-	-	-
30009	Reserved	-	-	-	-	-	-	-
30010	Reserved	-	-	-	-	-	-	-
30011	RA Temp.	-	-	-	•	-	-	-50.0 °C~100.0 °C (x10)
30012	Reserved	-	-	-	-	-	-	-
30013	SA Temp.	-	-	-	•	-	-	-50.0 °C~100.0 °C (x10)
30014	Reserved	-	-	-	-	-	-	-
30015	Reserved	-	-	-	-	-	-	-
30016	Reserved	-	-	-	-	-	-	-
40001	Operation Mode	-	-	•	-	-	•	0: Cooling / 2: Fan / 4: Heating
40002	Capacity <sup>1)</sup>	-	-	•	-	-	•	0, 2.0V~10V (x10, 0.5V)
40003	Cooling Target Temp.	-	-	•	-	-	•	16.0 °C~30.0 °C (x10, 1 °C)
40004	Heating Target Temp.	-	-	•	-	-	•	16.0 °C~30.0 °C (x10, 1 °C)
40005	Reserved	-	-	-	-	-	-	-
40006	Reserved	-	-	-	-	-	-	-
40007	Reserved	-	-	-	-	-	-	-
40008	Reserved	-	-	-	-	-	-	-
40009	Reserved	-	-	-	-	-	-	-
40010	Reserved	-	-	-	-	-	-	-
40028	Fan Speed	-	-	•	-	-	•	1 : Low / 2 : Middle / 3 : High

## NOTE

- Regarding capacity ratio, you can refer to the Capacity setting table of UI7(0~10V) of PAHCMS000.

- Error Code : 1 x xxx



# CONNECTION & SETTING GUIDE

## Fan & Alarm interlock guide

### 1 Return air temperature controller

If DO Type setting(SW 1-3) set as 'Status', fan operating signal can be interfaced with operation status signal at 'DO 1' in 'DIGITAL OUTPUT'

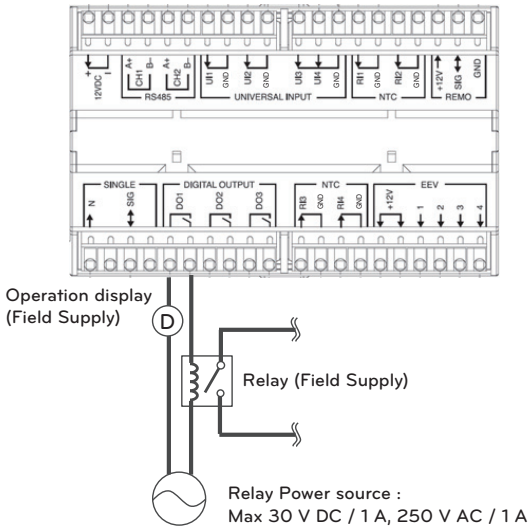

### NOTE

The fan is kept 'ON' during operation, If you want to turn off the fan during TH off or defrost or control by fan speed, please refer to DIP switch setting SW1-3&SW1-4 of Comm. module.

## 2 Discharge air temperature controller

Fan operating signal can be interfaced with operation status signal at 'DO 2' in 'DIGITAL OUTPUT' of main module.

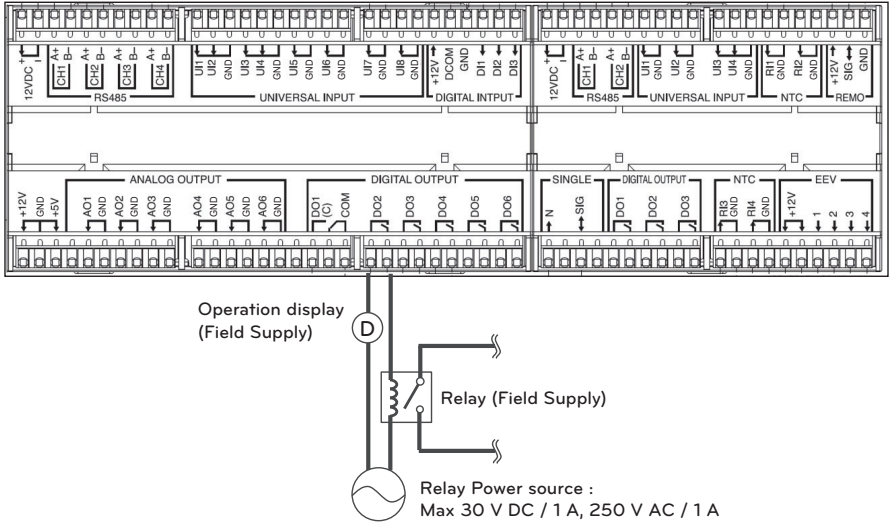

### NOTE

The fan is kept 'ON' during operation, If you want to control the fan according to defrost status and fan speed, please interlock defrost signal output(Main Module (Main Module DO 3) and fan speed signal output (Communication module DO 1 ~ 3).

Address setting guide(Remote controller & Central control)

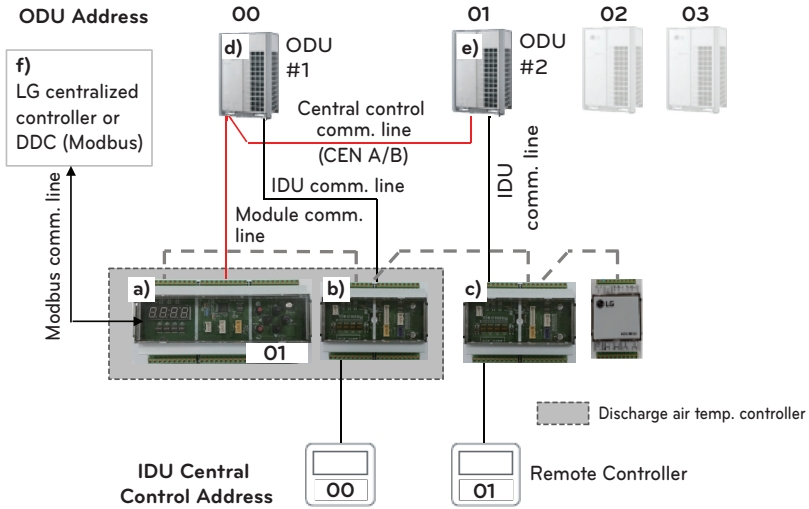

No	Contents	Address setting		Note
		Address	Method	
a)	Main module	01	By tact switch of Main module	For the Modbus communication - Please see "Main Module Address Setting"
b)	Communication module	00 (Fixed)	By remote controller	Please go to "Address Setting" of installer setting - Function code 02
c)	RA temp. controller	01 (Fixed)		
d)	Outdoor unit #1	00 (Fixed)	By tact switch of outdoor unit	The address of outdoor unit should be same as communication Module of PAHCMS000
e)	Outdoor unit #2	01 (Fixed)		
f)	LG central controller of DDC	1	By central controller's installation function	It should be matched with Main module's address

**NOTE**

- Remote controller should be connected to PAHCMS000 and remote controller connected to PAHCMR000 unit can only monitor status.
- LG Central controller addressing for discharge air temp. controller should be set as the same address of the main module's address.
- Address of Comm. module of PAHCMS000 (Central control address) must be set to '00'. The address for additional PAHCMR000 must be set with an order increasing by 1. Also ODU address must be the same as the paired AHU controller.
- All PAHCMR000 units need to be set as Master mode.
- Once Main module is turned on, It finds ODU from the ODU address 00→01→02→03 and finds Communication module from the IDU central controller address 00→01→02→03 and finds EEV module and then indicates total number of module. (Comm. module + EEV module)

# COMMUNICATION MODULE & EEV KIT CONNECTION GUIDE

- 1 Open the EEV Kit terminal box cover (A).
- 2 Check the marked color label and connect the cable using the driver (+).
  - Example) Model PRLK594A0
  - \* Electrical connection method of PRLK396A0 is the same as PRLK048 / PRLK096.

(Correct wiring)

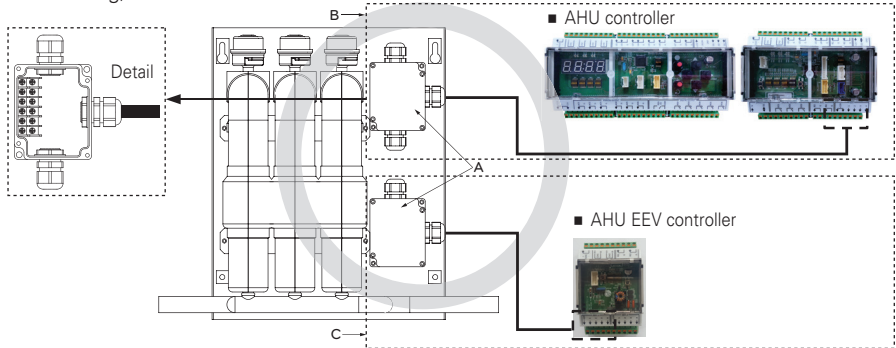

## ! WARNING

- Please connect one controller with one terminal block of EEV Kit. Failure to do so may result in component damage or fire. (Refer to correct wiring.)

(Incorrect wiring)

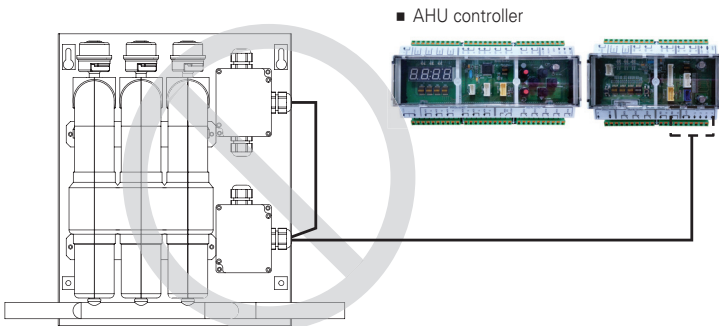

## ! WARNING

- Do not connect to the AHU Controller directly after wiring two terminal blocks together inside of the EEV Kit.

3 Use the screwdriver (+) to connect the EEV wires to the terminal block (D) according to the displayed instructions.

**B: Electrical connection #1**

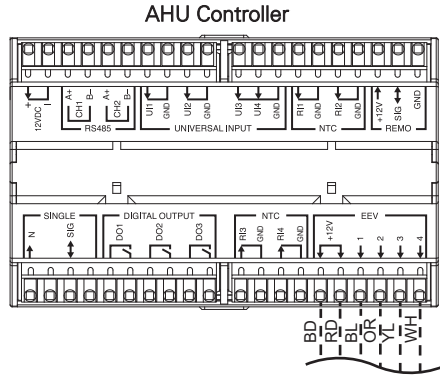
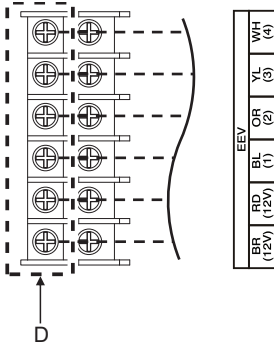

**C: Electrical connection #2**

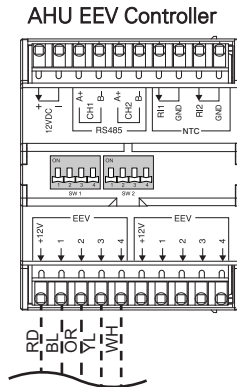
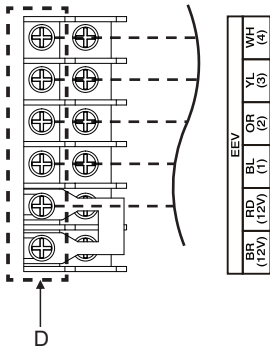

**Note**  
 BR : Brown  
 RD : Red  
 BL : Blue  
 OR : Orange  
 YL : Yellow  
 WH : White  
 - - - - : Field Wiring

**! WARNING**

- Before installation, check the color on the label and connect it to the terminal block.
- It may result in malfunction.
- Use a ring type terminal (P4) to connect to the terminal block.

# COMMKIT ERRORCODE

## ■ AHU CommKit ErrorCode List

Sub classification of errors	Error item	Error code	Location name	Remark
CH11xxx	Comm Module #1 Alarm	CH11501	Comm Module #1 Communication Error	Communication Error between the Main Module and Comm Module #1
		CH11511	EEV Module #1 Communication Error	Communication Error between the Main Module and EEV Module #1
		CH11001	Ventilation Temperature Sensor Error (Resistance Type)	The ventilation temperature sensor is disconnected or short-circuited.
		CH11002	Inlet Pipe Temperature Sensor Error (Resistance Type)	The inlet pipe temperature sensor is disconnected or short-circuited.
		CH11003	Remote Control Communication Defect	If the communication between the Comm Module #1 and the remote control is not established smoothly
		CH1006	Outlet Pipe Temperature Sensor Error (Resistance Type)	The outlet pipe temperature sensor is disconnected or short-circuited.
		CH1xxx	Outdoor Unit #1 Error	Refer to the outdoor unit (LGAP) error.
		Others	Reserved	Reserved
CH12xxx	Comm Module #2 Alarm	CH12501	Comm Module #2 Communication Error	Communication Error between the Main Module and Comm Module #2
		CH12511	EEV Module #2 Communication Error	Communication Error between the Main Module and EEV Module #2
		CH12001	Ventilation Temperature Sensor Error (Resistance Type)	The ventilation temperature sensor is disconnected or short-circuited.
		CH12002	Inlet Pipe Temperature Sensor Error (Resistance Type)	The inlet pipe temperature sensor is disconnected or short-circuited.
		CH12003	Remote Control Communication Defect	If the communication between the Comm Module #2 and the remote control is not established smoothly
		CH12006	Outlet Pipe Temperature Sensor Error (Resistance Type)	The outlet pipe temperature sensor is disconnected or short-circuited.
		CH12xxx	Outdoor Unit #2 Error	Refer to the outdoor unit (LGAP) error.
		Others	Reserved	Reserved



Manufacturer :  
LG Electronics Inc 84,  
Wanam-ro, Seongsan-gu, Changwon-si, Gyeongsangnam-do, KOREA

UK Importer :  
LG Electronics U.K. Ltd  
Velocity 2, Brooklands Drive, Weybridge, KT13 0SL