



# ELECTRIC & GAS DRYER SERVICE MANUAL

## ▲ CAUTION

READ THIS MANUAL CAREFULLY IN ORDER TO PROPERLY DIAGNOSE PROBLEMS  
AND TO SAFELY PROVIDE QUALITY SERVICE ON THESE DRYERS.

**MODEL : CDG27RSCNS / CDG27RSCES  
CDG27RUCNS / CDG27RUCES  
CDG27RLQNS / CDG27RLQES  
CDG27RSQNS / CDG27RSQES  
CDG27RUQNS / CDG27RUQES**



Any reproduction, duplication, distribution (including by way of email, facsimile or other electronic means), publication, modification, copying or transmission of this Service Manual is STRICTLY PROHIBITED unless you have obtained the prior written consent of the LG Electronics entity from which you received this Service Manual. The material covered by this prohibition includes, without limitation, any text, graphics or logos in this Service Manual.

Copyright © 2019-2021 LG Electronics Inc. All rights reserved. Only training and service purposes.

## IMPORTANT SAFETY NOTICE

The information in this service guide is intended for use by individuals possessing skill and experience in electrical, electronic, and mechanical appliance repair. Any attempt to repair a major appliance may result in injury to persons and property damage. The manufacturer or seller cannot be responsible for the interpretation of this information, nor can it assume any liability in connection with its use.

### WARNING

*To avoid injury to persons disconnect power before servicing this product. If electrical power is required for diagnosis or test purposes, disconnect the power immediately after performing the necessary checks.*

## RECONNECT ALL GROUNDING DEVICES

If grounding wires, screws, straps, clips, nuts, or washers used to complete a path to ground are removed for service, they must be returned to their original position and properly fastened.

## WHAT TO DO IF YOU SMELL GAS:

- *Do not try to light a match, or cigarette, or turn on any gas or electrical appliance.*
- *Do not touch any electrical switches. Do not use any phone in your building.*
- *Clear the room, building or area of all occupants.*
- *Immediately call your gas supplier from a neighbor's phone. Follow the gas supplier's instructions carefully.*
- *If you cannot reach your gas supplier, call the fire department.*

## IMPORTANT

Electrostatic Discharge (ESD)  
Sensitive Electronics

**ESD problems are present everywhere. ESD may damage or weaken the electronic control assembly. The new control assembly may appear to work well after repair is finished, but failure may occur at a later date due to ESD stress.**

- Use an anti-static wrist strap. Connect wrist strap to green ground connection point or unpainted metal in the appliance.

- OR -

**Touch your finger repeatedly to a green ground connection point or unpainted metal in the appliance.**

- Before removing the part from its package, touch the anti-static bag to a green ground connection point or unpainted metal in the appliance.
- Avoid touching electronic parts or terminal contacts. Handle electronic control assembly by edges only.
- Observe above instructions when repackaging failed electronic control assembly in an anti-static bag.

---

# CONTENTS

1. IMPORTANT SAFETY INSTRUCTIONS .....	4
2. SPECIFICATIONS .....	9
3. FEATURES AND BENEFITS .....	11
4. INITIAL STEPS FOR INSTALLING YOUR DRYER.....	13
5. STACK MACHINE INSTALLATION INSTRUCTIONS .....	19
6. ELECTRICAL REQUIREMENTS FOR ELECTRIC DRYERS .....	29
7. ELECTRICAL REQUIREMENTS FOR GAS DRYERS .....	34
8. GAS REQUIREMENTS AND INSTRUCTIONS .....	35
9. EXHAUST REQUIREMENTS AND MAINTENANCE .....	36
10. DRYER CYCLE PROCESS .....	40
11. COMPONENT TESTING INFORMATION .....	41
12. MOTOR DIAGRAM AND SCHEMATIC.....	44
13. CONTROL LAYOUT .....	45
14. WIRING DIAGRAM .....	46
15. DIAGNOSTIC TEST .....	47
15-1. TEST 1 120VAC ELECTRICAL SUPPLY .....	48
15-2. TEST 2 THERMISTOR TEST .....	51
15-3. TEST 3 MOTOR TEST .....	52
15-4. TEST 4 MOISTURE SENSOR.....	53
15-5. TEST 5 DOOR SWITCH TEST .....	54
15-6. TEST 6 HEATER SWITCH TEST - ELECTRIC MODEL .....	55
15-7. TEST 7 GAS VALVE TEST - GAS MODEL .....	56
16. ERROR MODE .....	57
17. SMART FUNCTIONS.....	58
18. CHANGE GAS SETTING (NATURAL GAS, PROPANE GAS) .....	61
19. DISASSEMBLY INSTRUCTIONS .....	63
20. EXPLODED VIEW .....	70
20-1-1. Control Panel & Plate Assembly - Coin Type.....	70
20-1-2. Control Panel & Plate Assembly - Card Type .....	71
20-2-1. Cabinet & Door Assembly - Electric Stack Upper Type .....	72
20-2-2. Cabinet & Door Assembly - Electric Stack Lower Type .....	73
20-2-3. Cabinet & Door Assembly - Gas Stack Upper Type .....	74
20-2-4. Cabinet & Door Assembly - Gas Stack Lower Type .....	75
20-3-1. Drum & Motor Assembly: Electric Type .....	76
19-3-2. Drum & Motor Assembly: Gas Type.....	77

## READ ALL INSTRUCTIONS BEFORE USE

**⚠ WARNING** For your safety, the information in this manual must be followed to minimize the risk of fire or explosion, electric shock, or to prevent property damage, injury to person, or death.

### Your Safety and the safety of others is very important.

We have provided many important safety messages in this manual and on your appliance. Always read and obey all safety messages.



This is the safety alert symbol.

This symbol alerts you to potential hazards that can kill or hurt you and others.

All safety messages will follow the safety alert symbol and either the word DANGER or WARNING. These words mean:

**⚠ DANGER:** You can be killed or seriously injured if you don't immediately follow instructions.

**⚠ WARNING:** You can be killed or seriously injured if you don't follow instructions.

All safety messages will tell you what the potential hazard is, tell you how to reduce the chance of injury, and tell you what can happen if the instructions are not followed.

## BASIC SAFETY PRECAUTIONS

**⚠ WARNING:** To reduce the risk of fire, electric shock, or injury to persons when using this appliance, follow basic precautions, including the following:

- Read all instructions before using the dryer.
- Before use, the dryer must be properly installed as described in this manual.
- Do not place items exposed to cooking oils in your dryer. Items contaminated with cooking oils may contribute to a chemical reaction that could cause a load to catch fire.
- Do not dry articles that have been previously cleaned in, washed in, soaked in, or spotted with gasoline, dry-cleaning solvents, or other flammable or explosive substances as they give off vapors that could ignite or explode.
- Do not reach into the dryer if the drum or any other part is moving.
- Do not repair or replace any part of the dryer or attempt any servicing unless specifically recommended in this Use and Care Guide or in published user-repair instructions that you understand and have the skills to carry out.
- Do not tamper with controls.
- Before the dryer is removed from service or discarded, remove the door to the drying compartment.
- Do not allow children to play on or in the dryer. Close supervision of children is necessary when the dryer is used near children.
- Do not use fabric softeners or products to eliminate static unless recommended by the manufacturer of the fabric softener or product.
- Do not use heat to dry articles containing foam rubber or similarly textured rubber-like materials.
- Keep area around the exhaust opening and adjacent surrounding areas free from the accumulation of lint, dust, and dirt.
- The interior of the dryer and exhaust vent should be cleaned periodically by qualified service personnel.
- Do not install or store the dryer where it will be exposed to the weather.
- Always check the inside of the dryer for foreign objects.
- Clean lint screen before or after each load.

---

## READ ALL INSTRUCTIONS BEFORE USE

**⚠ WARNING** For your safety, the information in this manual must be followed to minimize the risk of fire or explosion, electric shock, or to prevent property damage, injury to person, or death.

### **⚠ WARNING**

#### **FIRE OF EXPLOSION HAZARD**

Failure to follow safety warnings exactly could result in serious injury, death or property damage.

- Do not store or use gasoline or other flammable vapors and liquids in the vicinity of this or any other appliance.

#### **- WHAT TO DO IF YOU SMELL GAS**

- Do not try to light any appliance.
- Do not touch any electrical switch; do not use any phone in your building.
- Clear the room, building or area of all occupants.
- Immediately call your gas supplier from a neighbors phone. Follow the gas suppliers instructions.
- If you cannot reach your gas supplier, call the fire department.
- Installation and service must be performed by a qualified installer, service agency or the gas supplier.

## **CALIFORNIA SAFE DRINKING WATER AND TOXIC ENFORCEMENT ACT**

This act requires the governor of California to publish a list of substances known to the state to cause cancer, birth defects, or other reproductive harm and requires businesses to warn customers of potential exposure to such substances.

Gas appliances can cause minor exposure to four of these substances, namely benzene, carbon monoxide, formaldehyde, and soot, caused primarily by the incomplete combustion of natural gas or LP fuels.

Properly adjusted dryers will minimize incomplete combustion. Exposure to these substances can be minimized further by properly venting the dryer to the outdoors.

---

## READ ALL INSTRUCTIONS BEFORE USE

**⚠ WARNING** For your safety, the information in this manual must be followed to minimize the risk of fire or explosion, electric shock, or to prevent property damage, injury to person, or death.

### GROUNDING INSTRUCTIONS

This appliance must be grounded. In the event of malfunction or breakdown, grounding will reduce the risk of electric shock by providing a path of least resistance for electric current. This appliance must be equipped with a cord having an equipment-grounding conductor and a grounding plug. The plug must be plugged into an appropriate outlet that is properly installed and grounded in accordance with all local codes and ordinances.

**⚠ WARNING** Improper connection of the equipment-grounding conductor can result in a risk of electric shock. Check with a qualified electrician or service

person if you are in doubt as to whether the appliance is properly grounded.

Do not modify the plug provided with the appliance. If it will not fit the outlet, have a proper outlet installed by a qualified electrician.

This appliance must be connected to a grounded metal, permanent wiring system or an equipment-grounding conductor must be run with the circuit conductors and connected to the equipment-grounding terminal or lead on the appliance.

Electric shock can result if the dryer is not properly grounded.

### SAFETY INSTRUCTIONS FOR INSTALLATION

**⚠ WARNING** To reduce the risk of fire, electric shock, or injury to persons when using this appliance, follow basic precautions, including the following:

- **Properly ground dryer to conform with all governing codes and ordinances.** Follow details in the installation instructions. Electric shock can result if the dryer is not properly grounded.
- **Before use, the dryer must be properly installed as described in this manual.** Electric shock can result if the dryer is not properly grounded.
- **Install and store the dryer where it will not be exposed to temperatures below freezing or exposed to the weather.**
- **All repairs and servicing must be performed by an authorized servicer unless specifically recommended in this Owner's Guide. Use only authorized factory parts.** Failure to follow this warning can cause serious injury, fire, electrical shock, or death.
- **To reduce the risk of electric shock, do not install the dryer in humid spaces.** Failure to follow this warning can cause serious injury, fire, electric shock, or death.
- **Connect to a properly rated, protected, and sized power circuit to avoid electrical overload.** Improper power circuit can melt, creating electric shock and/or fire hazard.
- **Remove all packing items and dispose of all shipping materials properly.** Failure to do so can result in death, explosion, fire, or burns.
- **Place dryer at least 18 in. above the floor for a garage installation.** Failure to do so can result in death, explosion, fire, or burns.
- **Keep all packaging from children.** Packaging material can be dangerous for children. There is a risk of suffocation.

---

# READ ALL INSTRUCTIONS BEFORE USE

**⚠ WARNING** For your safety, the information in this manual must be followed to minimize the risk of fire or explosion, electric shock, or to prevent property damage, injury to person, or death.

## SAFETY INSTRUCTIONS FOR INSTALLATION

Exhaust/Ducting:

- **Gas dryers MUST be exhausted to the outside.** Failure to follow these instructions can result in fire or death.
- **The dryer exhaust system must be exhausted to the outside of the dwelling. If the dryer is not exhausted outdoors, some fine lint and large amounts of moisture will be expelled into the laundry area.** An accumulation of lint in any area of the home can create a health and fire hazard.
- **Use only rigid metal or flexible metal 4-in. diameter ductwork inside the dryer cabinet or for exhausting to the outside. Use of plastic or other combustible ductwork can cause a fire.** Punctured ductwork can cause a fire if it collapses or becomes otherwise restricted in use or during installation.
- **Ductwork is not provided with the dryer, and you should obtain the necessary ductwork locally. The end cap should have hinged dampers to prevent backdraft when the dryer is not in use.** Failure to follow these instructions can result in fire or death.
- **The exhaust duct must be 4 in. (10 cm) in diameter with no obstructions. The exhaust duct should be kept as short as possible. Make sure to clean any old ducts before installing your new dryer.** Failure to follow these instructions can result in fire or death.
- **Rigid or semi rigid metal ducting is recommended for use between the dryer and the wall. In special installations when it is impossible to make a connection with the above recommendations, a UL-listed flexible metal transition duct may be used between the dryer and wall connection only. The use of this ducting will affect drying time.** Failure to follow these instructions can result in fire or death.
- **Do not use sheet metal screws or other fasteners which extend into the duct that could catch lint and reduce the efficiency of the exhaust system. Secure all joints with duct tape. For complete details, follow the Installation Instructions.** Failure to follow these instructions can result in fire or death.
- **Keep the area underneath and around your appliances free of combustible materials such as lint, paper, rags, chemicals, etc.** Failure to do so can result in fire.

### ⚠ WARNING

Fire Hazard

Failure to follow safety warning exactly could result in serious injury, death or property damage.

Do not install a booster fan in the exhaust duct.

Install all clothes dryers in accordance with the installation instructions of the manufacturer of the dryer.

---

## READ ALL INSTRUCTIONS BEFORE USE

**⚠ WARNING** For your safety, the information in this manual must be followed to minimize the risk of fire or explosion, electric shock, or to prevent property damage, injury to person, or death.

### SAFETY INSTRUCTIONS FOR CONNECTING ELECTRICITY

**⚠ WARNING:** To reduce the risk of fire, electric shock, or injury to persons when using this appliance, follow basic precautions, including the following:

- **Do not, under any circumstances, cut or remove the ground prong from the power cord.** To prevent injury to person or damage to the dryer, the electrical power cord must be plugged into a properly grounded outlet.
- **For personal safety, this dryer must be properly grounded.** Failure to do so can result in electric shock or injury.
- **Refer to the installation instructions in this manual for specific electrical requirements for your model.** Failure to follow these instructions can create an electric shock hazard and/or a fire hazard.
- **This dryer must be plugged into a properly grounded outlet. Electric shock can result if the dryer is not properly grounded. Have the wall outlet and circuit checked by a qualified electrician to make sure the outlet is properly grounded.** Failure to follow these instructions can create an electric shock hazard and/or a fire hazard.
- **The dryer should always be plugged into its own individual electrical outlet which has a voltage rating that matches the rating plate.** This provides the best performance and also prevents overloading house wiring circuits which could cause a fire hazard from overheated wires.
- **Never unplug your dryer by pulling on the power cord. Always grip plug firmly and pull straight out from the outlet.** The power cord can be damaged, resulting in a risk of fire and electric shock.
- **Repair or replace immediately all power cords that have become frayed or otherwise damaged. Do not use a cord that shows cracks or abrasion damage along its length or at either end.** The power cord can melt, creating electric shock and/or fire hazard.
- **When installing or moving the dryer, be careful not to pinch, crush, or damage the power cord.** This will prevent injury and prevent damage to the dryer from fire and electric shock.
- **To reduce the risk of injury to person, adhere to all industry recommended safety procedures including the use of long sleeved gloves and safety glasses.** Failure to follow all of the safety warnings in this manual could result in property damage, injury to person or death.
- **Connect the power cord to the terminal block. Each colored wire should be connected to same color screw. Wire color indicated on manual is connected to the same color screw in block.** Failure to follow these instructions may result in a short or overload.

**⚠ WARNING**  
ELECTRIC SHOCK HAZARD

Failure to follow safety warnings could result in serious injury or death.

This dryer is equipped with a three-prong grounding plug to protection against shock hazard and should be plugged directly into a properly grounded three-prong receptacle. Do not cut or remove the grounding prong from this plug.

## SAVE THESE INSTRUCTIONS

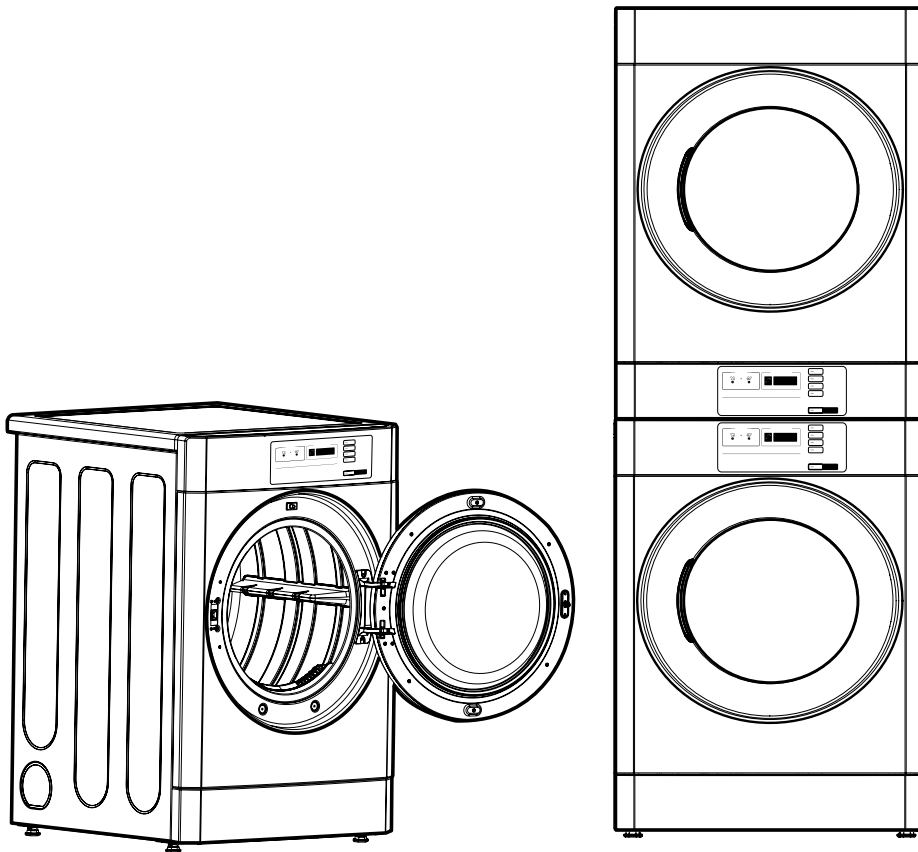

- Type : Electric and Gas Dryer
- Rating : Please refer to the rating label regarding detailed information.
- Single dryer Size : 686mm(W) x 764mm(D) x 983mm(H)  
27in(W) X 30in(D) X 38.7in(H)
- Stack dryer Size : 686mm(W) x 764mm(D) x 1954mm(H)  
27in(W) X 30in(D) X 76.9in(H)
- Capacity : IEC 7.3 cu.ft. (22.5 lb)
- Weight : 131 lbs (59.4 kg)
- Specifications are subject to change by manufacturer.

ITEM		CDG27RLCES CDG27RSCES CDG27RUCES	CDG27RLCNS CDG27RSCNS CDG27RUCNS	REMARK
TYPE		Electric	Gas (LNG)	
POWER SUPPLY		120/240V, 24 Amps	120V, 7 Amps	
MATERIAL & FINISH	Color	Stainless Silver		
	Top Plate	Powder Painted / Porcelain		
	Door Trim	Stainless Deco		
	Door Frame	Chrome		
	C/Panel Color	Stainless Silver		
ELECTRICITY CONSUMPTION	MOTOR	420W (4.5V)		AC 120V
	HEATER	5400W (22.5A)	-	AC 240V (ELECTRIC MODEL)
	GAS VALVE	-	13W (110mA) x 2	
CONTROL TYPE		Electronic		
DRUM CAPACITY		IEC 7.3 cu.ft.		
Weight (lbs.) - Net/Gross		126/144		
No. of Programs		4		
Audible End of Cycle Beeper		Available		
Time dry		Available		
Reversible Door		Available		
Drum		Alcosta		
Product (WxHxD)		686mm(W) x 764mm(D) x 983mm(H)		
Packing (WxHxD)		29 7/10(W) x 44 7/10(H) x 31 2/5(D) (Inch)		

# 3

# FEATURES AND BENEFITS

## Accessories

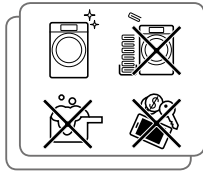

OPL sheet  
(only for OPLtype)

## Control panel features

### ■ Card type

Side by side (CDG27RSCNS / CDG27RSCES)

Stack upper (CDG27RUCNS / CDG27RUCES)

Stack lower (CDG27RLCNS / CDG27RLCES)

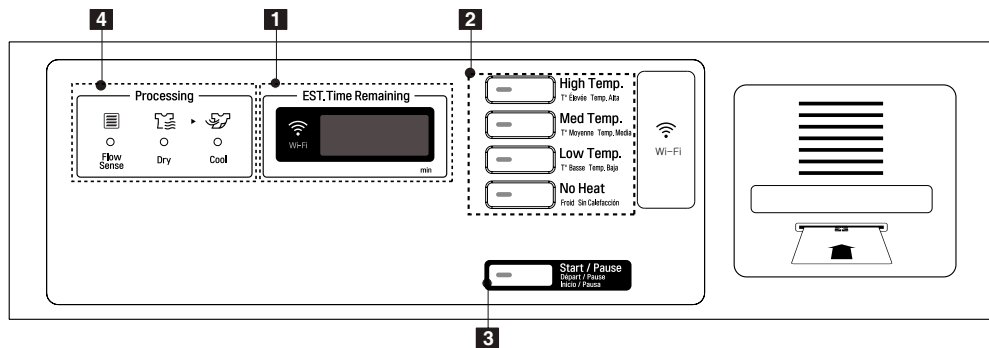

### ■ OPL type

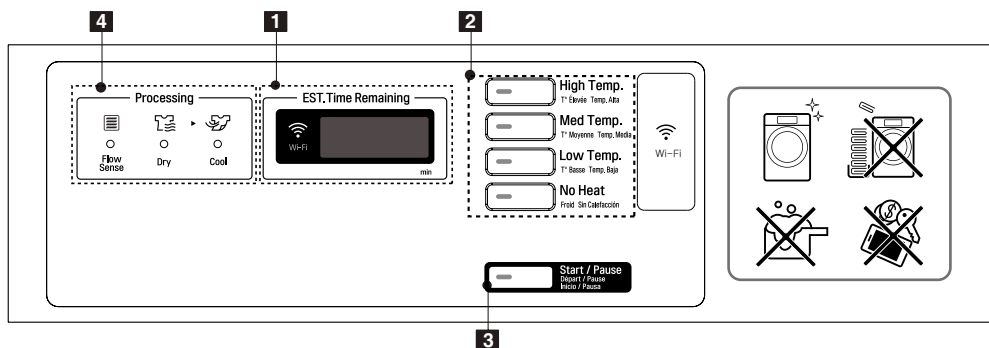

- 1. Display LED
- 2. Cycle button

- 3. Start / Pause button
- 4. Status LED

## Control panel features

- Coin type
  - Side by side (CDG27RSQNS / CDG27RSQES)

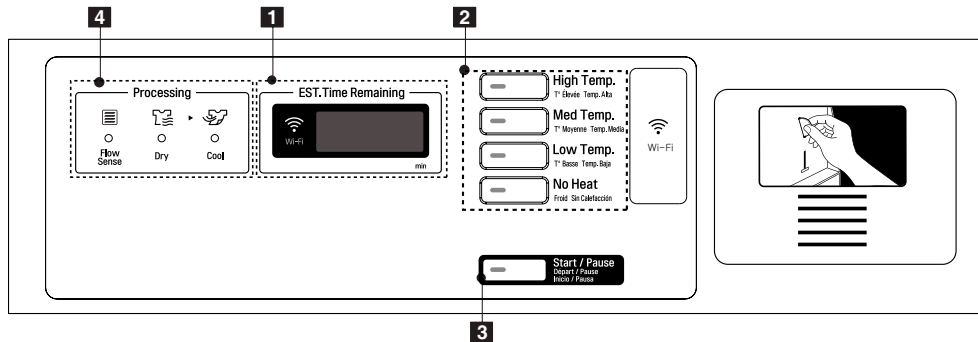

- Stack Upper (CDG27RUQNS / CDG27RUQES)

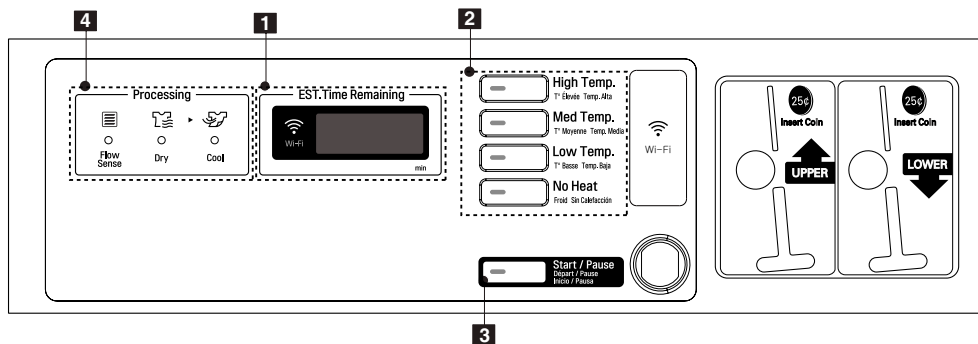

- Stack lower (CDG27RLQNS / CDG27RLQES)

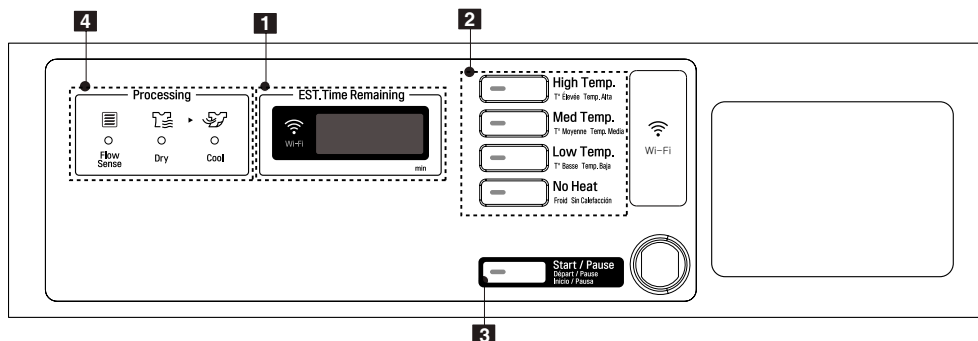

1. Display LED  
2. Cycle button

3. Start/Pause button  
4. Status LED

# 4

## INITIAL STEPS FOR INSTALLING YOUR DRYER

The following instructions will help guide you through the initial steps of setting up your dryer for use. Please note that every section of this manual provides important information regarding the preparation and use of your dryer, and it is important that you review this entire manual before proceeding with any installation or use. More detailed instructions concerning electrical connections, gas connections, and exhaust requirements are provided at other parts of this manual.

### STEP 1 Positioning the Dryer.

Choose a location with a solid floor for your dryer. Place the dryer at least eighteen inches above the floor for a garage installation. After placing the dryer in the desired location, please make sure that it has the required clearances shown below, and sections on Exhaust and Maintenance requirements.

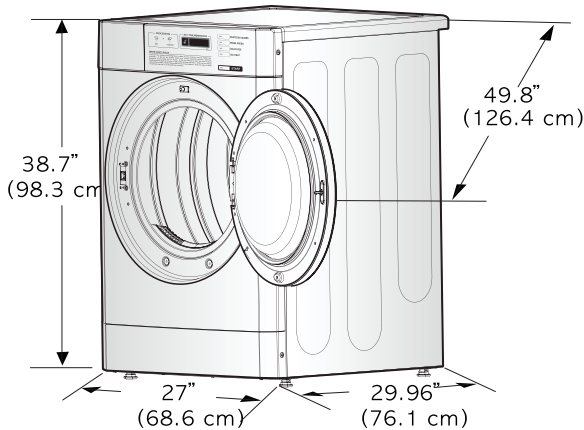

\* Most installations require a minimum 5 1/2 in. (14 cm) clearance behind the dryer for the exhaust vent with elbow.

#### Note

**Level the dryer using the leveling legs and tighten the adjusting nuts to hold them in place.**

**All four legs should be placed firmly on a solid and even floor.**

**If the dryer is not level, the clothes will not tumble properly and the sensor will not be able to detect the dryness level accurately.**

**Adjust the leveling legs carefully to avoid injury.**

#### Note

**No other fuel-burning appliance shall be installed in the same closet as the dryer.**

**This applies only to dryers suitable for installation in a closet.**

#### ⚠ WARNING

**The appliances are heavy. Two or more people are required when moving or installing the appliance. There is a risk of serious back injury or other injuries.**

**Certain minimum clearances are required above, behind, and to the sides of the unit, as shown below.** Those required minimum clearances are set forth in the picture below. Please also keep the following instructions in mind when installing in a closet or recessed area:

- Consider allowing additional clearance for installation and servicing.
- Wall, door and floor molding may force additional clearances.
- An additional inch of clearance is recommended to minimize noise transfer .
- Consider space needed for companion appliances.
- For closet installations, the picture below shows the minimum required ventilation openings for the door. A louvered door with comparable ventilation openings is also acceptable.

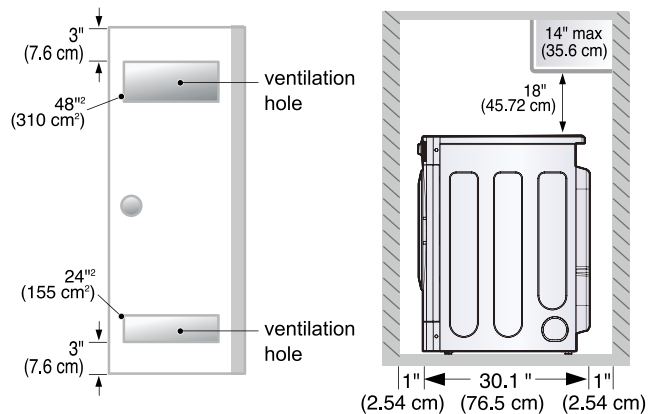

Closet door

Closet-Side view



Closet-Front view

Once in position, adjust the leveling legs of the dryer until it is level from left to right and from front to back. The leveling legs must remain firmly on the floor and the dryer should not rock. The maximum slope of the dryer from left to right or from front to back should not exceed 2.5 cm (1 inch). If the dryer is not level, and if the slope exceeds 2.5 cm (1 inch), a load may not tumble properly and internal sensors may malfunction. Note: Other sections of this manual also provide important information concerning the placement of and clearances for your dryer. Please review this entire manual before proceeding with any installation.

## STEP 2 Procedure for Reversing the Door

The door on your dryer can be installed to open either to the left or the right. Follow these procedures to reverse the direction in which your door opens:

### Note

**Door and latch should be aligned at the center when closed. Otherwise, the door will not open, close, or latch properly.**

1

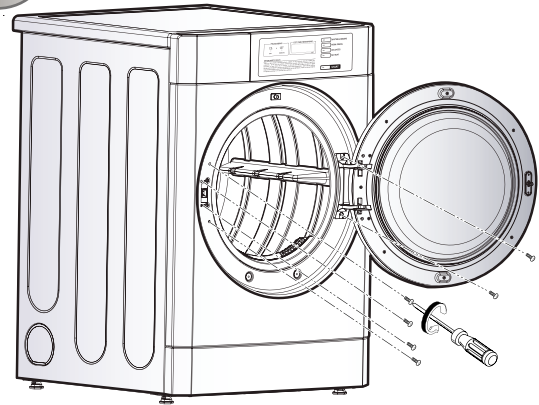

2



3

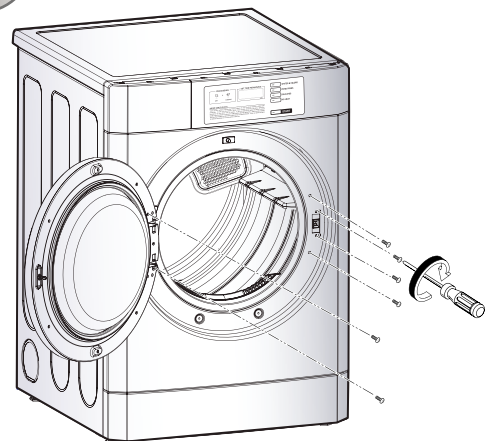

## STEP 3 Connecting the Exhaust and Venting System.

### ⚠ WARNING

- Use a heavy metal vent.
- Do not use plastic or thin foil duct.
- Clean old ducts before installing this dryer.
- Failure to follow these instructions can result in death or fire.

### Note

Vent pipe and fittings must be installed with the smaller ends facing away from the dryer. Incorrect installation of the vent and improper taping of the joints will interfere with correct dryer and vent function.

In addition to the following warnings, please refer to manual section on Exhaust Requirements and Maintenance. **IMPORTANT:** To reduce the risk of fire, combustion, and gas accumulation, the dryer must be vented to the outdoors. Please follow the instructions (and all others in this manual) very carefully.

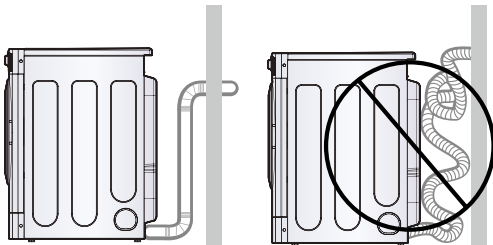

- Do not use plastic or thin foil duct.
- Use 4" (10.2 cm) diameter rigid or semi-rigid metal duct (note: venting materials are not supplied with the dryer, and you must obtain the venting materials necessary for proper installation)
- Position the dryer so the exhaust duct run is as short as possible.
- Clean old ducts before installing this dryer
- The male end of each section of exhaust duct must point away from the dryer
- Use as few elbow joints as possible.
- Use duct tape on all duct joints
- Insulate ductwork that runs through unheated areas in order to reduce condensation and lint build-up on pipe walls; and
- **PLEASE BE AWARE THAT FAILURE TO EXHAUST THE DRYER CORRECTLY WILL VOID THE DRYER'S WARRANTY.**

### ■ ALTERNATE EXHAUST DIRECTIONS

1. Remove the screw that attaches the duct's tab to the dryer.

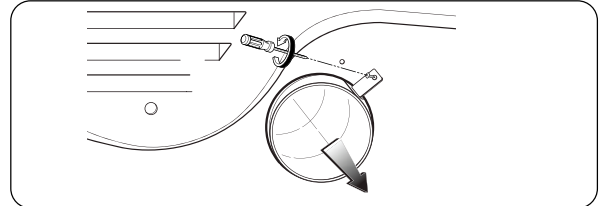

- 2-1. Detach and remove the knockout that matches the desired venting direction (Right side not available on Gas Dryers) Follow steps 1, 2, and 3, as shown below.

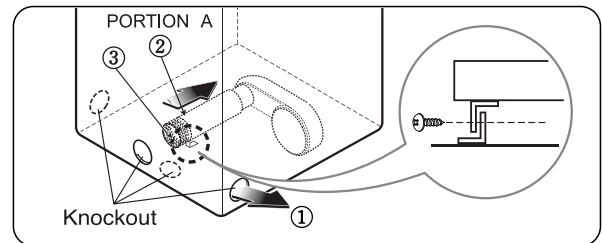

- 2-2. Reconnect the duct to the blower housing and attach the duct to the base. The side vent kit is available as a service part, #383EEL9001B.

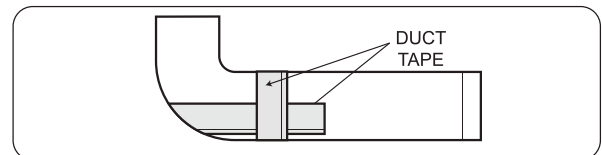

- 3-1. Pre-assemble a 4" elbow with a 4" duct. Wrap duct tape around joint.

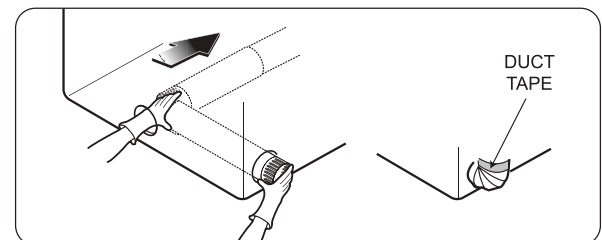

- 3-2. Insert the elbow duct assembly first through the side opening and connect the elbow to the internal duct.

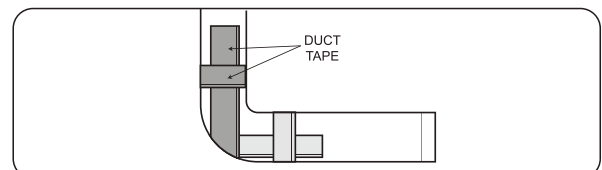

## STEP 4 Connection of Gas Supply

(Gas dryer only). In addition to the following, please refer to manual section on Gas Requirements and Instructions.

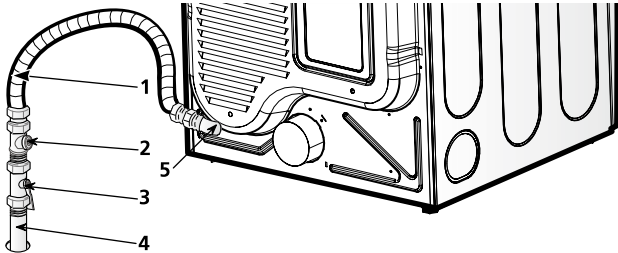

1. New stainless steel flexible connector. Use this type of connector only if allowed by local codes. Use Design AGA Certified Connector.
2. 1/8" NPT Pipe Plug (for checking inlet gas pressure)
3. Equipment Shut-Off Valve- Installed within 6'(1.8m) of dryer
4. Iron Pipe. Shorter than 20'(6.1m) Use 3/8" pipe. Longer than 20'(6.1m) - Use 1/2" pipe.
5. 3/8" N.P.T. Gas Connection
6. Apply pipe joint compound or about 1 1/2 wraps of Teflon tape over all threaded connection

### Note

Make sure the burner orifice is proper for the type of gas you are provided with. For instance, using LPG with LNG orifice will result in death, fire, or explosion. Using LNG with LPG orifice will not ignite burner. If needed, orifice conversion should be done by a qualified service technician and mark or place the label of the current type of orifice on the dryer.

1. Confirm that the type of gas available in your laundry room is appropriate for the dryer. The dryer is prepared for Natural Gas with a 3/8" NPT gas connection.
2. Remove the shipping cap from the gas connection at the back of the dryer. Make sure that you don't damage the threads of the gas connection pipe when you remove the shipping cap.
3. Connect the dryer to your laundry room's gas supply using a new flexible stainless steel connector (as noted below, only use a new stainless steel flexible connector if allowed by your local codes).
4. Securely tighten all connections between the dryer and your laundry room's gas supply. Turn on your laundry room's gas supply and check all pipe connections (both internal and external) for gas leaks with a non-corrosive leak detection fluid. Refer to Part 7 (page 20)
5. For LP (Liquefied Petroleum) gas connection, refer to this manual's section entitled Gas Requirements and Instructions.

## STEP 5 Electrical Plug Connections

Following are several warnings and instructions concerning making the electrical connection for electric dryers. More detailed information concerning the electrical connection is provided at the manual section entitled Electrical Requirements for Electric Dryer. It is important that you thoroughly review that section, and the remainder of this manual before taking any steps to install or use this dryer.

1. Use only a new U.L. listed No. 10 (copper wire only) three conductor power supply cord kit rated 240 Volts (minimum) 30 Amperes and labeled as suitable for use in a clothes dryer.
2. Four-wire cord is required for manufactured (mobile) home installations and use and where local codes do not allow grounding of this appliance through neutral.
3. Electrical Plug Connections.
4. For additional instruction on connecting the dryer to an electrical power source, please refer to this manual's section on Electrical Requirements and Electric Dryer.

### Note

Burner input requirements:

Adjusting burner input setting is not needed (at the elevation up to 10,000 feet) because AGA certifies this dryer will not have any problem with the BTU rating. If your house is at above 10,000 feet, you are required to adjust a four percent (4%) reduction of the burner BTU rating indicated on the model/serial rating plate.

## ▲ WARNING

- Use a new UL approved 30 amp power supply cord or 10 gauge solid copper wire.
- Use a UL approved strain relief.
- Disconnect power before making electrical connections.
- Connect neutral wire (white or center wire) to center terminal.
- Ground wire (green or bare wire) must be connected to green ground connector.
- Securely tighten all electrical connections
- See installation instructions for complete instructions.
- Failure to do so can result in fire or electric shock.

## STEP 6 Preparation of the Dryer

Prior to the first use of this appliance, use all-purpose cleaning products or a solution of detergent and water, with damp clothes to remove from the inside of the dryer drum/drying compartment any dust or dirt that may have accumulated the inside of the dryer. Plug-in your dryer after reviewing the following parts on your dryer's Electrical Requirements.

## STEP 7 Confirming Heat Source Operation

### Confirming Heat Source in Gas Dryers

Close the door to the dryer drum/drying compartment and, after completing all steps in this manual for proper installation of this dryer, start the dryer on a heat setting, as described more fully in the operating instructions that accompany the dryer. After the dryer starts, the igniter will glow red and the main burner will ignite.

#### Note

**If all air is not purged from the gas line, the gas igniter may go off before the gas and the main burner have ignited. If this happens, the igniter will re-attempt gas ignition after approximately two minutes.**

### Confirming Heat Source in Electric Dryers

Close the door to the dryer drum/drying compartment and, after completing all steps in this manual for proper installation of this dryer, start the dryer on a heat setting, as described more fully in the operating instructions that accompany the dryer. The exhaust air or the exhaust pipe should be warm after the dryer has been operating for three minutes.

## STEP 8 Dryer Airflow

Effective dryer operation requires appropriate dryer airflow. The adequacy of the airflow can be measured by evaluating the static pressure. Static pressure in the exhaust duct can be measured with a manometer, placed on the exhaust duct approximately 2 ft. (60.9 cm) from the dryer. Static pressure in the exhaust duct should not exceed 0.6 inches (1.5 cm). The dryer should be checked with the dryer running with no load.

### Measuring Static Pressure

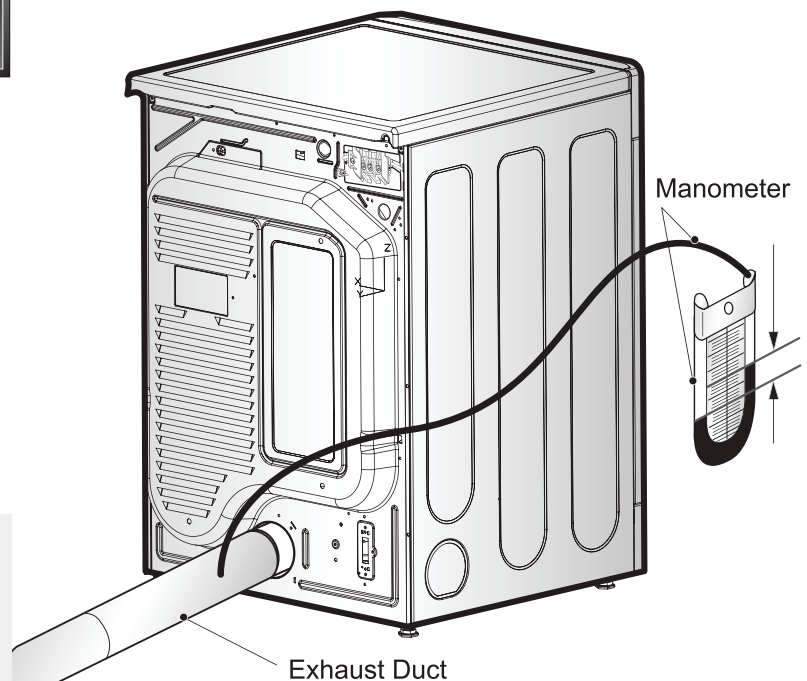

**MAXIMUM STATIC  
PRESSURE IN  
WATER COLUMN**

0.6 inch (1.5 cm)

### **⚠ WARNING**

- The dryer must be disconnected from the gas supply piping system during pressure testing.
- Failure to do so can result in death, explosion, or fire.

## STEP 9 Additional Instructions for Installation of Your Dryer in a Manufactured or Mobile Home.

The following instructions are applicable to installations of the dryer in a manufactured or mobile home. Any installation in a manufactured or mobile home must comply with the Manufactured Home Construction and Safety Standards Title 24 CFR, Part 32-80 or Standard CAN/CSA0Z240 MH and local codes and ordinances. If you are uncertain whether your proposed installation will comply with these standards, please contact a service and installation professional for assistance.

The following instructions apply to any installation of the dryer in a manufactured or mobile home:

- 1) The gas dryer must be permanently attached to the floor.
- 2) The electrical connection for an electric dryer must be a 4-wire connection. More detailed information concerning the electrical connection is provided at the manual section entitled Electrical Requirements for Electric Dryer
- 3) To reduce the risk of combustion and fire, the dryer must be vented to the outside.

### **WARNING**

Do not connect exhaust ducts with metal screws or fasteners that extend into the duct.

- 4) Electric dryers may be vented to the outside using the back, left, right, or bottom panel.
- 5) Gas dryers may be vented to the outside using the back, left, or bottom panel. Gas dryer may not be vented to the outside using the right side panel because of the burner housing.
- 6) The dryer exhaust duct must be affixed securely to the manufactured or mobile home structure, and the exhaust duct must be made of a material that will resist fire and combustion, and it is recommended that you use a rigid or flexible metal pipe.
- 7) DO NOT connect the exhaust duct with any other duct, vent, chimney, or other exhaust duct.
- 8) Make sure the dryer has adequate access to outside fresh air to ensure proper operation. The opening for outside fresh air must be at least 25 in<sup>2</sup> (163 cm<sup>2</sup>).
- 9) It is important that the clearance of the duct from any combustible construction be at least 2 inches (5 cm), and, when venting the dryer to the outdoors, the dryer can be installed with a clearance of 1 inch at the sides and back of the dryer.
- 10) Please be aware that venting materials are not supplied with the dryer. You should obtain the venting materials necessary for proper installation.

### **WARNING**

Do not vent the exhaust duct under the manufactured or mobile home.

# 5

## STACK MACHINE INSTALLATION INSTRUCTIONS

### 1 Single Coin & Card

#### 1-1 Coin/Card housing

##### How to connect the housing

The dryer has a connector for both a coin collector and a card reader. Use the one you need and tuck the other one away safely.

#### 1-2 COIN TYPE

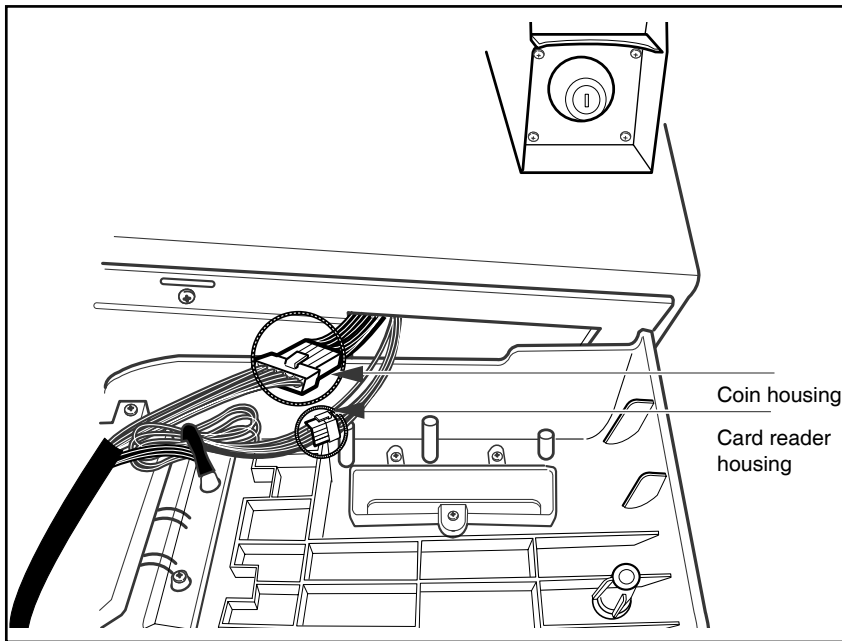

When power on the machine at first time without connecting card reader or coin housing ,display will show LqC1

#### 1-3 CARD TYPE (Single)

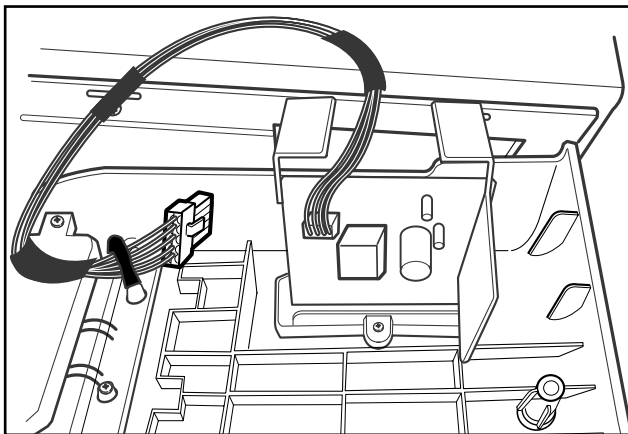

### **⚠ WARNING**

- **Disconnect power before service.**
- Failure to follow these instructions can result in death or electric shock.

#### **Note**

The Coin drop assembly operates on DC12V in dryer.  
The Card reader assembly operates on DC12V in dryer.

## 2 SUITABLE MODEL FOR STACKING

Stack type	Upper Dryer	Lower Dryer	Lower Washer
Model Name	GDL1329CEW7, GDL1329CGW7	GDL1329CED7, GDL1329CGD7	GCWW1069CD7
	GDL1329QEW7, GDL1329QGW7	GDL1329QED7, GDL1329QGD7	GCWW1069QD7

## 3 STACKING KIT

- STACKING KIT is provided in the upper dryer.



- STACKING KIT includes the stacking bracket(1), sec unity bracket(3), bolt(1), screw(9).

1) Stacking bracket



2) bolt

3) Screw

4) security bracket

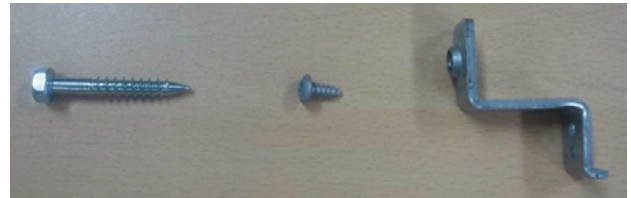

- SLDING KIT includes the silde bracket(2), sliding pad(4), screw(18).

1) Sliding Blacket



2) Sliding pad

3) Screw



### Note

- This machine can be stacked only on the model designated as suitable by LGE.
- Do not stack the washer on the top.

### 3-1 Security bracket installation

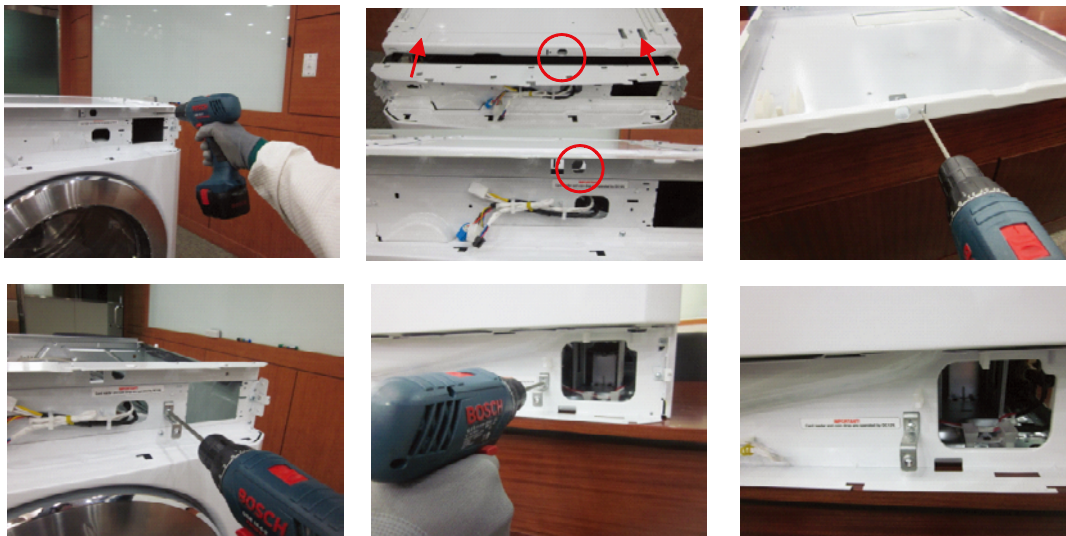

- Fasten two(2) screws at the top plate.
- Disassemble the top plate from lower machine.
- Install the security bracket in the top plate.
- Install the security bracket on the upper and lower panel frame.

### 3-2 Sliding kit installation



- Install two sliding brackets on the top plate of lower washer.
- Check the direction of the sliding bracket. (R-Right L-Left)
- It is the same method for washer and dryer.

---

### 3-3 Sliding pad Installation (Upper Dryer)

---

#### 1) Leg removal



- Lay the upper dryer, set the bottom of the upper dryer.
- Remove the legs from the leg brackets.

#### 2) Leg bracket removal

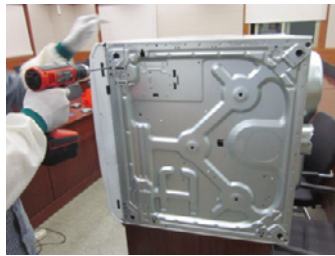
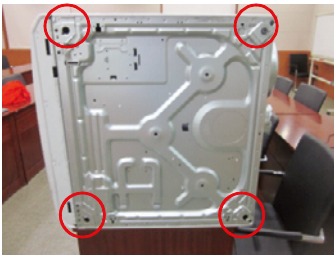

- Loosen the black screw fixing the leg bracket.
- Remove the four(4) leg brackets from the bottom of upper dryer.

#### 3) Sliding pad installation

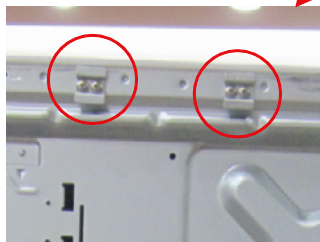

- There are eight(8) screw holes at both side of the bottom.
- Assemble the four(4) slide pads on the base.
- Tighten two(2) screws per each slide.

---

### 3-4 Control panel replace (Upper Dryer)

---

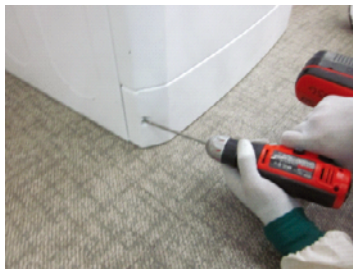

- Loosen two(2) screws of each panel.
- Remove upper and lower panel from the dryer.
- Separate the blue and white connectors from control panel.
- Assemble the lower panel to upper panel frame.

### 3-5 Coin harness installation

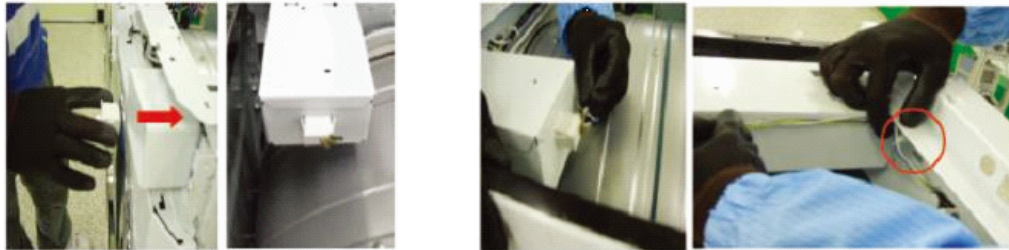

- Insert the switch into the recess on the back of the coin box.
- Face it toward the front so the coin box will press the button when it is in place.
- Connect the coin box switch at this time.



Upper dryer coin harness

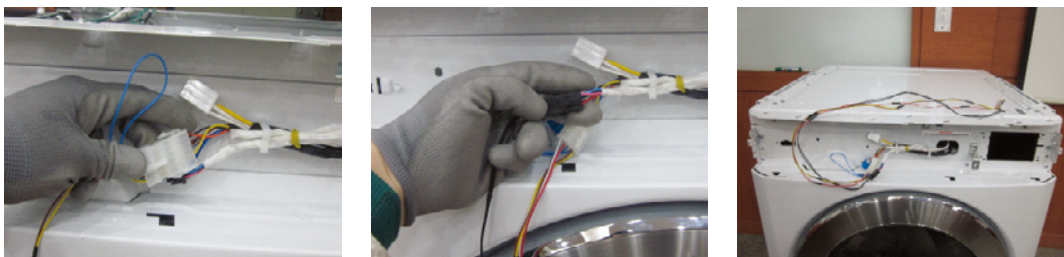

Lower dryer coin harness

- Connect the white and black connectors.
- It is the same method for upper and lower.

#### Note

Please refer to Service Manual for detail and check how to stack and fix the machine

---

### 3-6 Stacking the machine

---



- Lift and stack the upper dryer on the lower washer.
- Set the rear of the upper dryer and the rear of the lower washer in the same position.
- Push the upper dryer matching the slide & stacking bracket to make upper and lower front parallel.

### 3-7 Stacking bracket installation

---

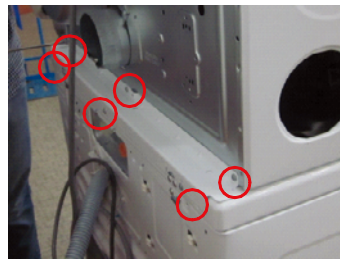

- Install the stacking bracket at the rear of the stacked dryer and washer.
- Assemble the six(6) screw to fix the lower machine and upper dryer.

### 3-8 Coindrop Installation

---



- Install the coindrop to the control panel of upper dryer

### 3-9 Connecting coindrop and machines

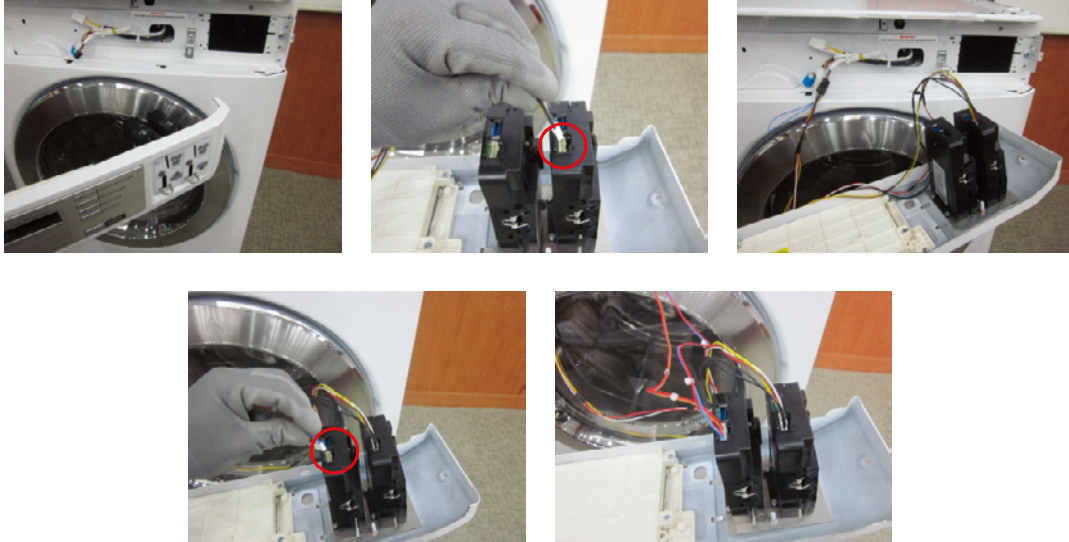

- Connect the lower coin harness to right coindrop.
- Connect the upper coin harness to left coindrop.

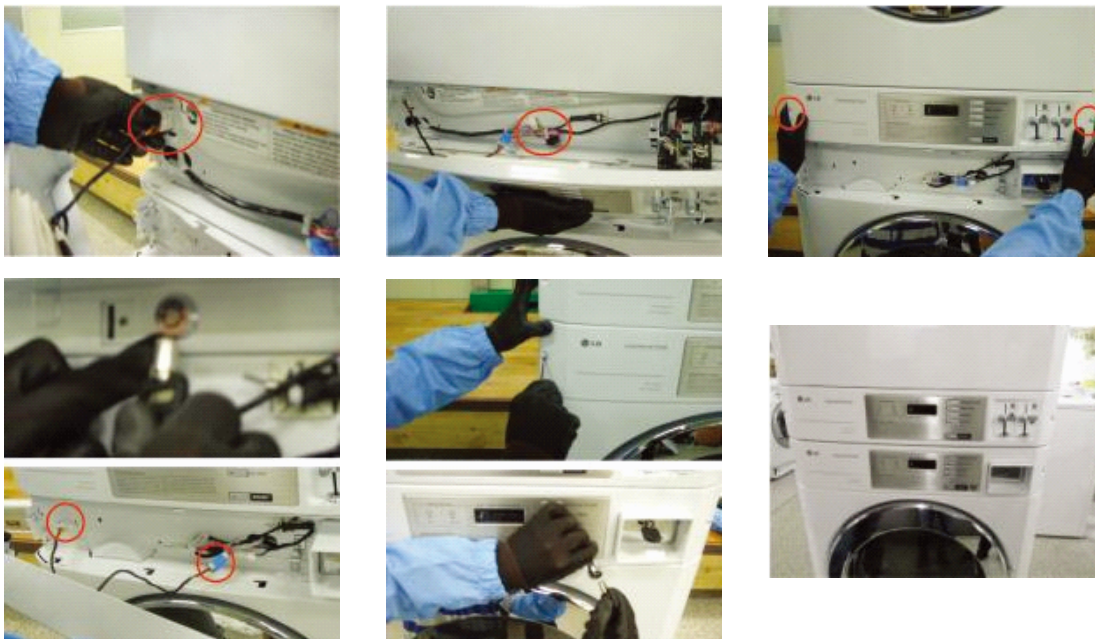

- Install the blue and white connector of the control panel to upper dryer.
- Assemble the control panel of upper dryer.
- Assemble the control panel of lower washer/dryer.

---

## 4 Installation Method— Card Type

---

Stacking Card

▶ Different point between Coin type and Card type

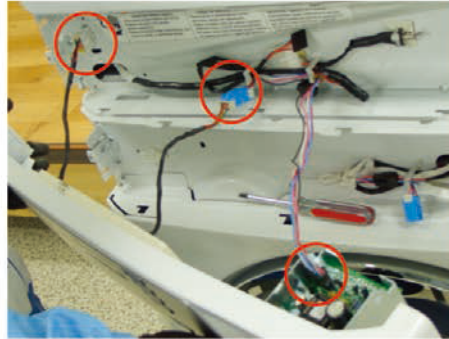
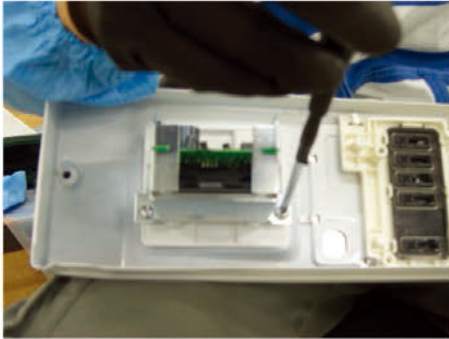

---

## Connect Gas Supply Pipe (Gas Dryer ONLY)

---

For further assistance, refer to section on **Gas Requirements**.

1. Make certain your dryer is equipped for use with the type of gas in your laundry room. Dryer is equipped at the factory for natural gas with a 3/8" NPT gas connection.
2. Remove the shipping cap from the gas connection at the rear of the dryer. Make sure you do not damage the pipe thread when removing the cap.
3. Connect to gas supply pipe using a new flexible stainless steel connector.
4. Tighten all connections securely. Turn on gas and check all pipe connections (internal & external) for gas leaks with a non-corrosive leak detection fluid.
5. For L.P. (Liquefied Petroleum) gas connection, refer to section on Gas Requirements.

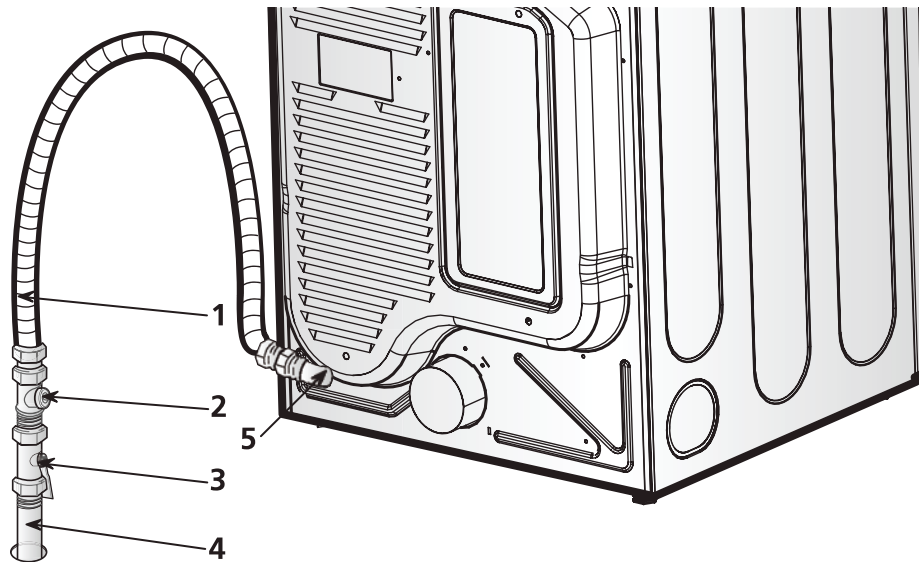

- 1 New Stainless Steel Flexible Connector - Use only if allowed by local codes (Use Design A.G.A. Certified Connector)
- 2 1/8" N.P.T. Pipe Plug (for checking inlet gas pressure)
- 3 Equipment Shut-Off Valve-Installed within 6' (1.8 m) of dryer

- 4 Black Iron Pipe  
Shorter than 20' (6.1 m) - Use 3/8" pipe  
Longer than 20' (6.1 m) - Use 1/2" pipe
- 5 3/8" N.P.T. Gas Connection

## CONNECTING ELECTRIC DRYERS

**⚠ WARNING:** To help prevent fire, electric shock, serious injury or death, the wiring and grounding must conform to the latest edition of the National Electrical Code, ANSI/NFPA 70 and all applicable local regulations. Please contact a qualified electrician to check your home's wiring and fuses to ensure that your home has adequate electrical power to operate the dryer.

*Electrical Requirements for Electric Models Only*

**⚠ WARNING:** To reduce the risk of fire, electric shock, or injury to persons when using this appliance, follow basic precautions, including the following:

- **This dryer must be connected to a grounded metal, permanent wiring system, or an equipment-grounding conductor must be run with the circuit conductors and connected to the equipment-grounding terminal or lead on the dryer.** Failure to do so can result in fire, explosion, or death.
- **The dryer has its own terminal block that must be connected to a separate 240 VAC, 60-Hertz, single-phase circuit, fused at 30 amperes (the circuit must be fused on both sides of the line). ELECTRICAL SERVICE FOR THE DRYER SHOULD BE OF THE MAXIMUM RATE VOLTAGE LISTED ON THE NAMEPLATE. DO NOT CONNECT DRYER TO 110-, 115-, OR 120-VOLT CIRCUIT.** Heating elements are available for field installation in dryers which are to be connected to an electrical service of a different voltage than that listed on the rating plate. Failure to follow these instructions can result in fire, explosion, or death.
- **If branch circuit to dryer is 15 ft. (4.5 m) or less in length, use UL (Underwriters Laboratories) listed No.-10 AWG wire (copper wire only), or as required by local codes. If over 15 ft. (4.50 m), use UL-listed No.-8 AWG wire (copper wire only), or as required by local codes. Allow sufficient slack in wiring so dryer can be moved from its normal location when necessary.** Failure to do so can result in fire, explosion, or death.
- **The power cord (pigtail) connection between wall receptacle and dryer terminal block IS NOT supplied with dryer. Type of pigtail and gauge of wire must conform to local codes and with instructions on the following pages.** Failure to follow these instructions can result in fire, explosion, or death.
- **A 4-wire connection is required for all mobile and manufactured home installations, as well as all new construction after January 1, 1996. A 4-wire connection must be used where local codes do not permit grounding through the neutral wire.** Failure to do so can result in fire, explosion, or death.

*Special Electrical Requirements for Mobile or Manufactured Homes*

**⚠ WARNING:** To reduce the risk of fire, electric shock, or injury to persons when using this appliance, follow basic precautions, including the following:

- Any installation in a manufactured or mobile home must comply with the Manufactured Home Construction and Safety Standards Title 24 CFR, Part 32-80 or Standard CAN/CSA02240 MH and local codes and ordinances.
- **A 4-wire connection is required for all mobile and manufactured home installations, as well as all new construction after January 1, 1996.** Failure to do so can result in fire, explosion, or death.

## CONNECTING ELECTRIC DRYERS

### **⚠ WARNING:**

- Connect the power cord to the terminal block. Each colored wire should be connected to same color screw. Wire color indicated on manual is connected to the same color screw in block. Failure to follow these instructions may result in a short or overload.
- Grounding through the neutral conductor is prohibited for: (1) new branch-circuit installations, (2) mobile homes, (3) recreational vehicles, and (4) areas where local codes prohibit grounding through the neutral conductor.



#### *Four-Wire Connection for Electric Dryers: Power Cord*

- A 4-wire connection is required for all mobile and manufactured home installations, as well as all new construction after January 1, 1996.
- A UL-listed strain relief is required.
- Use a 30-amp, 240V, UL-listed power cord with #10 AWG-minimum copper conductor and closed loop or forked terminals with upturned ends.

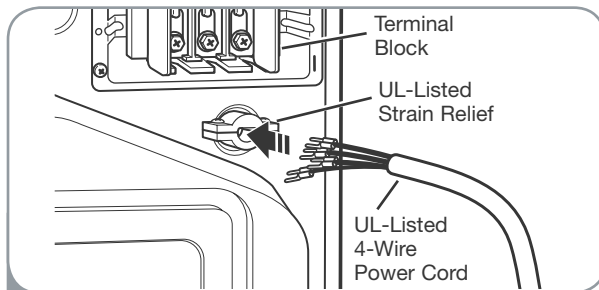

- 1 Remove the terminal block access cover on the upper back of the dryer. Install a UL-listed strain relief into the power cord through-hole; then thread a UL-listed, 30A, 240V, 4-wire, #10 AWG-minimum copper conductor power cord through the strain relief.

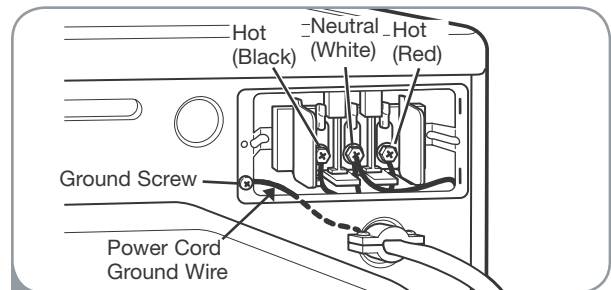

- 2 Transfer the dryer's ground wire from behind the green ground screw to the center screw of the terminal block. Attach the two hot leads of the power cord to the outer terminal block screws. Attach the white neutral wire to the center terminal block screw. Attach the power cord ground wire to the green ground screw. **TIGHTEN ALL SCREWS SECURELY.** Reinstall the terminal block access cover.

## CONNECTING ELECTRIC DRYERS (cont.)

### **⚠ WARNING:**

- Connect the power cord to the terminal block. Each colored wire should be connected to same color screw. Wire color indicated on manual is connected to the same color screw in block. Failure to follow these instructions may result in a short or overload.
- Grounding through the neutral conductor is prohibited for: (1) new branch-circuit installations, (2) mobile homes, (3) recreational vehicles, and (4) areas where local codes prohibit grounding through the neutral conductor.

### *Four-Wire Connection for Electric Dryers: Direct Wire*

- A 4-wire connection is required for all mobile and manufactured home installations, as well as all new construction after January 1, 1996.
- A UL-listed strain relief is required.
- Use UL-listed 4-wire #10 AWG-minimum copper conductor cable.
- Allow at least 5 ft (1.5 m) length to allow for removal and reinstallation of the dryer.

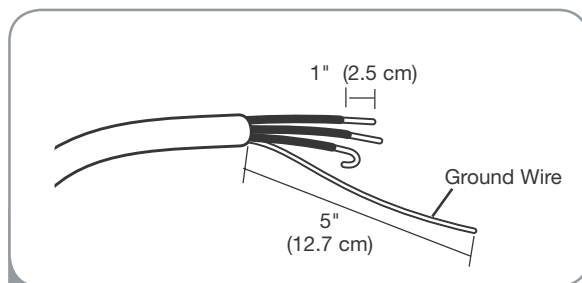

- 1 Remove 5 inches (12.7 cm) of the outer covering from the wire. Remove 5 inches of insulation from the ground wire. Cut off approximately 1½ inches (3.8 cm) from the the other three wires and strip 1 inch (2.5 cm) insulation from each wire. Bend the ends of the three shorter wires into a hook shape.

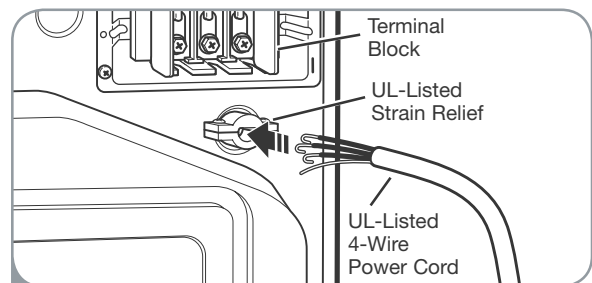

- 2 Remove the terminal block access cover on the upper back of the dryer. Install a UL-listed strain relief into the power cord through-hole; then thread the power cable prepared in Step 1 through the strain relief.

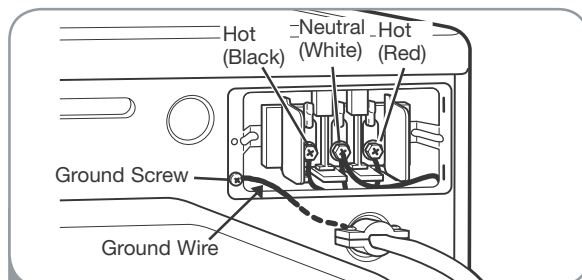

- 3 Transfer the dryer's ground wire from behind the green ground screw to the center screw of the terminal block. Attach the two hot leads of the power cable to the outer terminal block screws. Attach the white neutral wire to the center terminal block screw. Attach the power cable ground wire to the green ground screw. **TIGHTEN ALL SCREWS SECURELY.** Reinstall the terminal block access cover.

## CONNECTING ELECTRIC DRYERS (cont.)

### **⚠️WARNING:**

- Connect the power cord to the terminal block. Each colored wire should be connected to same color screw. Wire color indicated on manual is connected to the same color screw in block. Failure to follow these instructions may result in a short or overload.
- Grounding through the neutral conductor is prohibited for: (1) new branch-circuit installations, (2) mobile homes, (3) recreational vehicles, and (4) areas where local codes prohibit grounding through the neutral conductor.



#### *Three-Wire Connection for Electric Dryers: Power Cord*

- A 3-wire connection is NOT permitted on new construction after January 1, 1996.
- A UL-listed strain relief is required.
- Use a 30-amp, 240V, UL-listed power cord with #10 AWG-minimum copper conductor and closed loop or forked terminals with upturned ends.

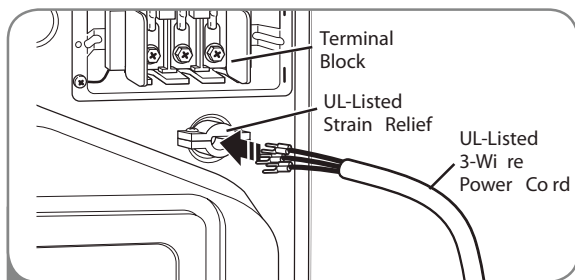

- 1 Remove the terminal block access cover on the upper back of the dryer. Install a UL-listed strain relief into the power cord through-hole; then thread a UL-listed, 30A, 240V, 3-wire, #10 AWG-minimum copper conductor power cord through the strain relief.

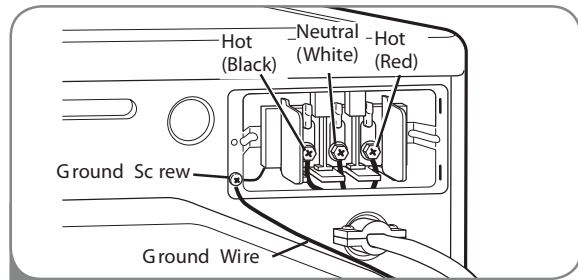

- 2 Attach the two hot leads of the power cord to the outer terminal block screws. Attach the neutral wire to the center terminal block screw. Connect the external ground (if required by local codes) to the green ground screw. **TIGHTEN ALL SCREWS SECURELY.** Reinstall the terminal block access cover.

## CONNECTING ELECTRIC DRYERS (cont.)

### **⚠ WARNING:**

- Connect the power cord to the terminal block. Each colored wire should be connected to same color screw. Wire color indicated on manual is connected to the same color screw in block. Failure to follow these instructions may result in a short or overload.
- Grounding through the neutral conductor is prohibited for: (1) new branch-circuit installations, (2) mobile homes, (3) recreational vehicles and (4) areas where local codes prohibit grounding through the neutral conductor.

#### *Three-Wire Connection for Electric Dryers: Direct Wire*

- A 3-wire connection is NOT permitted on new construction after January 1, 1996.
- A UL-listed strain relief is required.
- Use UL-listed 3-wire #10 AWG–minimum copper conductor cable.
- Allow at least 5 ft (1.5 m) length to allow for removal and reinstallation of the dryer.

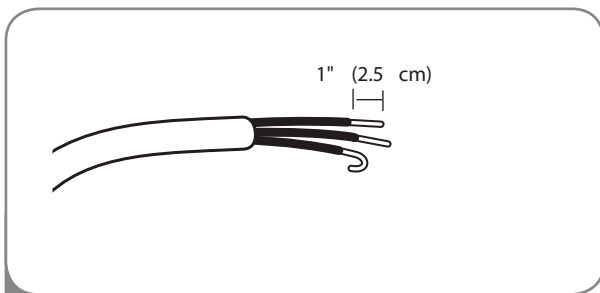

- 1 Remove 3½ inches (8.9cm) of the outer covering from the wire. Strip 1 inch (2.5cm) insulation from each wire. Bend the ends of the three wires into a hook shape.

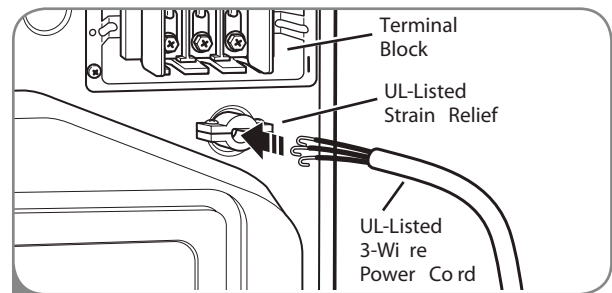

- 2 Remove the terminal block access cover on the upper back of the dryer. Install a UL-listed strain relief into the power cord through-hole; then thread the power cable prepared in Step 1 through the strain relief.

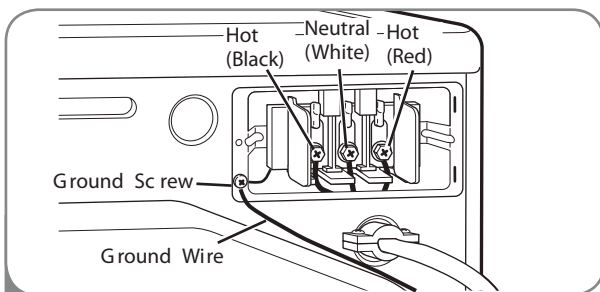

- 3 Attach the two hot leads of the power cord to the outer terminal block screws. Attach the neutral wire to the center terminal block screw. Connect the external ground (If required by local codes) to the green ground screw. **TIGHTEN ALL SCREWS SEVURELY.** Reinstall the terminal block access cover.

# ELECTRICAL REQUIREMENTS FOR GAS DRYERS

## 120 Volt, 60 Hertz, with 3-Prong Grounding Plug

Following are additional instructions regarding electrical connections and requirements for gas dryers.

**⚠ WARNING:** The wiring and grounding must conform to the latest edition of the National Electrical Code, ANSI/NFPA 70, or the Canadian Electrical Code, CSA C22.1, and all applicable local regulations. Please contact a qualified electrician to check your home's wiring and fuses to ensure that your home has adequate electrical power to operate the dryer. Failure to do so can result in fire or electric shock.

### Electrical Requirements for Your Dryer:

- Please note that the wiring diagram is provided inside the dryer control hood. Label all wires prior to disconnection when servicing the dryer, because wiring errors can cause serious injury to you and your dryer.
- Your dryer is designed to be used on a separate branch, polarized, three-wire, effectively grounded, 120 Volt, 60 Hertz, AC (alternating current) circuit protected by a 15 Ampere fuse, equivalent fuse or circuit breaker.
- Use separately fused circuits for washers and dryers, and DO NOT operate a washer and a dryer on the same circuit.

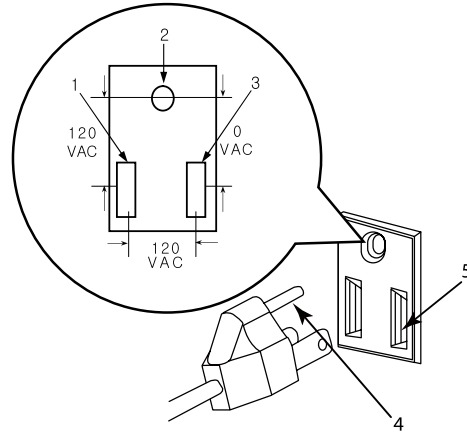

**STANDARD 120 VOLT, 60 HERTZ, 3-WIRE EFFECTIVELY GROUNDED CIRCUIT**

- |   |                 |
|---|-----------------|
| 1 | L1              |
| 2 | Ground          |
| 3 | Neutral Side    |
| 4 | Grounding Prong |
| 5 | Neutral         |

- The dryer has a three-prong plug to help guard against shock. The plug should be plugged directed into a properly grounded three-prong receptacle that is rated 120 Volts AC (alternating current) 15 Amps. This plug, in order to be properly and fully effective, must be plugged into a properly installed outlet that is grounded in accordance with all local codes and ordinances.
- The dryer must be grounded in order to reduce the risk of electric shock, including a malfunction or breakdown.
- If your laundry room does not meet the specifications required by this manual, or if you are uncertain whether or not your laundry room meets these specifications, please have a qualified service person or company. Review your laundry room's electrical supply for any problems.

### ⚠ WARNING

- Do not overload the circuit by operating other appliances on the same circuit when this appliance is operating, by using an extension cord to connect the dryer to the power source, or by using any adapter to allow additional cords to connect to the same outlet.
- Failure to do so can result in fire or electric shock.

### ⚠ WARNING

- Do not modify the plug provided with the dryer. If it does not fit the outlet in your laundry room, a proper outlet will need to be installed in your laundry room by a qualified service person or company.
- Failure to do so can result in fire or electric shock.

Following are important instructions and information concerning the requirements for the gas supply and service for gas dryers. **⚠ IMPORTANT WARNING: The gas supply and service for a gas dryer must comply with all local codes and ordinances. In the absence of any local codes or ordinances in your area, the gas supply and service for your gas dryer must comply with the latest edition of the National Fuel Gas Code, ANSI Z223.1/ NFPA 54(USA) or Canadian gas installation code CAS B149.1(Canada).**

1. Gas supply requirements: Liquefied Petroleum (L.P.) Gas (2,500 Btu/ft<sup>3</sup> (93.1 MJ/m<sup>3</sup>)) service must be provided at 10 + 1.5 in. water column pressure.
2. Do not attempt to connect the dryer to Liquefied Petroleum (LP Gas) Gas service without a qualified professional.
3. Isolate the dryer from the gas supply piping system by closing its individual manual shut-off valve during any pressure testing of the gas supply system at test pressure equal to or less than 1/2 psi (3.45 kPa).
4. Supply Line Requirements. Your laundry room must have a rigid gas supply line to your dryer. In the United States, an individual manual shutoff valve **MUST** be installed within at least 6 feet (1.8 m) of the dryer, in accordance with the National Fuel Gas Code ANSI Z223.1 or Canadian gas installation code CSA B149.1.  
A 1/8 in. N.P.T. pipe plug must be installed as shown.
5. If using a rigid pipe, the rigid pipe should be 1/2 inch IPS. If acceptable under local codes and ordinances and when acceptable to your gas supplier, 3/8 inch approved tubing may be used where lengths are less than 20 feet (6.1 m). Larger tubing should be used for lengths in excess of 20 feet (6.1 m). It is also important that you use pipe joint compound that is insoluble in LP gas.
6. To reduce the danger of gas leaks, explosion, and fire, please follow and observe the following **instructions and WARNINGS**.
  - Connect the dryer to the type of gas shown on the nameplate.
  - Use new flexible stainless steel connectors.
  - Use Teflon tape and pipe joint compound insoluble in LP gas on all pipe threads.
  - Purge gas supply of air and sediment before connecting the gas supply to the dryer in order to prevent gas valve contamination. Before tightening connection between gas supply and dryer, purge remaining air until odor of gas is identified.
  - **DO NOT** use an open flame to inspect for gas leaks; instead use a non-corrosive leak detection fluid.

### **⚠ WARNING**

- **Do not attempt any disassembly of the dryer. Any disassembly requires the attention and tools of an authorized and qualified service person or company.**
- Failure to do so can result in death, explosion, or fire.

### **⚠ WARNING**

- **Use a new AGA or CSA approved gas supply line.**
- **Install a shut-off valve.**
- **Securely tighten all gas connections.**
- **If connected to LP, have a qualified person make sure gas pressure does not exceed 13 in. water column.**
- **Examples of a qualified person include licensed heating personnel, authorized gas company personnel, and authorized service personnel.**
- Failure to do so can result in death, explosion, or fire.

Following are important instructions and information concerning the exhaust requirements for your dryer.

**⚠ WARNING:** Do not exhaust dryer air into an enclosed and unventilated area, such as an attic, wall, ceiling, crawl space, chimney, gas vent, or concealed space of a building. To reduce the risk of fire, Do not exhaust the dryer with plastic or thin foil Ducting. Failure to do so can result in death, explosion, or fire.

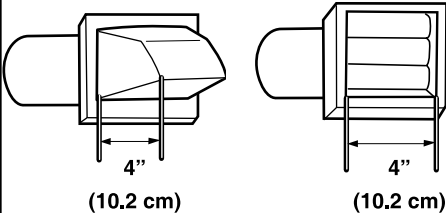
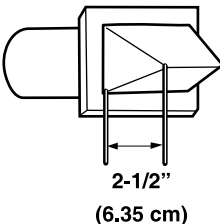
Weather Hood Type	Number of 90° Elbows	Maximum length of 4" (10.2 cm) diameter rigid metal duct	Maximum length of 4" (10.2 cm) diameter flexible metal duct
<b>Recommended</b> 	0	65 feet (19.8 m)	45 feet (13.7 m)
	1	55 feet (16.8 m)	35 feet (10.7 m)
	2	47 feet (14.3 m)	30 feet (9.1 m)
	3	36 feet (11.0 m)	25 feet (7.6 m)
	4	28 feet (8.5 m)	20 feet (6.1 m)
<b>Use Only for Short Run Installations</b> 	0	55 feet (16.8 m)	35 feet (10.7 m)
	1	47 feet (14.3 m)	27 feet (8.2 m)
	2	41 feet (12.5 m)	21 feet (6.4 m)
	3	30 feet (9.1 m)	17 feet (5.2 m)
	4	22 feet (6.7 m)	15 feet (4.5 m)

**NOTE :** Deduct 6 feet (1.8 m) for each additional elbow.

It is not recommended to use more than 4 90° elbows.

### Exhaust Requirements and Instructions:

1. Venting materials are not provided with the dryer and you should obtain the necessary venting materials locally. For example, the outer end of exhaust pipe must have a weather hood with hinged dampers to prevent back-draft when the dryer is not in use.
2. The exhaust duct must be four inches (10.2 cm) in diameter with no obstructions. The exhaust duct should be kept as short as possible. Make sure to clean any old ducts before installing your new dryer.
3. Rigid or semi-rigid metal ducting is recommended for use as transition ducting between the dryer and the wall. In special installations when it is impossible to make a connection with the above recommendations, then a UL-listed flexible metal transition duct may be used between the dryer and wall connection only. The use of this ducting will affect dry time.
4. DO NOT use sheet metal screws on exhaust pipe joints or other fastening means which extend into the duct that could catch lint and reduce the efficiency of the exhaust system. Secure all joints with duct tape.
5. To maximize operating results, please observe the duct length limitations noted in the chart above.

---

## NATURAL MULTIPLE VENTING SYSTEM

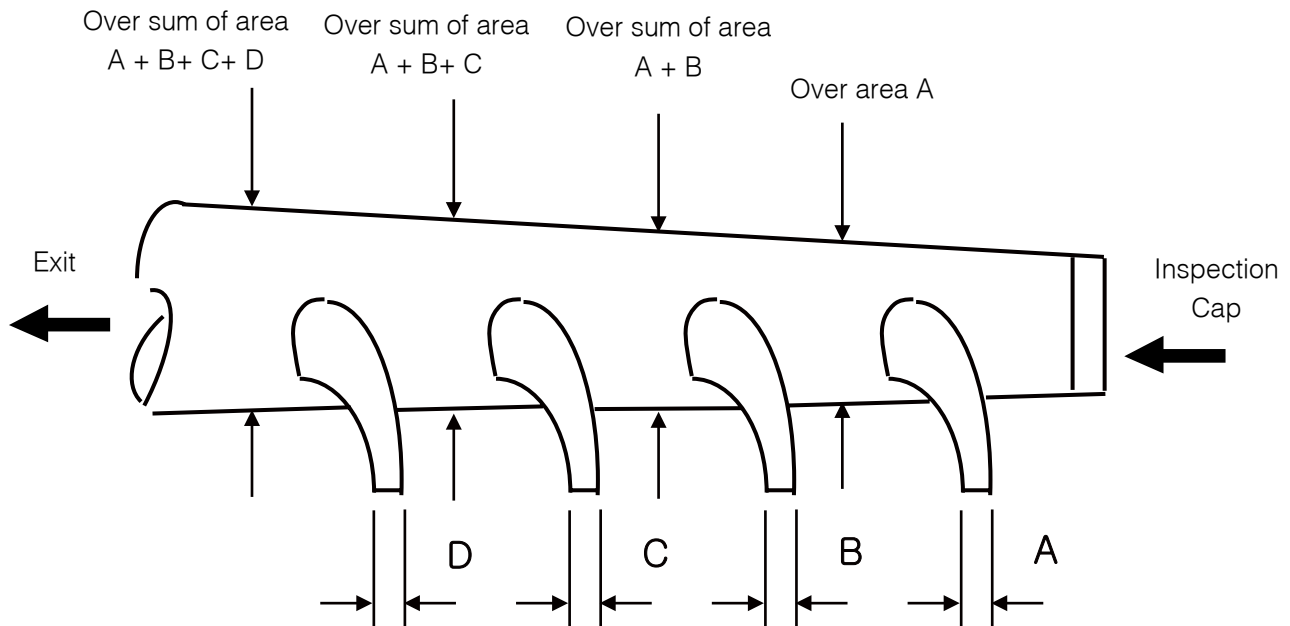

**\* Lg exhaust Duct Diameter: ①100mm**

- Use the exhaust duct over the inner diameter of exhaust pipe.
- Do not use too small inner diameter of exhaust pipe or too long exhaust duct, Because it makes bad ventilation and low drying performance and it will be cause of trouble.
- Follow the below guide in case of using gathering exhaust duct installed with over 2 duct.
- Incline the exhaust duct toward exit about an 45 angle when exhaust duct from dryer is connected to main exhaust duct. ( If you don't make perpendicular connection, airflow is disturbed.)

# FORCED MULTIPLE VENTING SYSTEM

Use adjust damper to fit airflow velocity 5m/s at exit

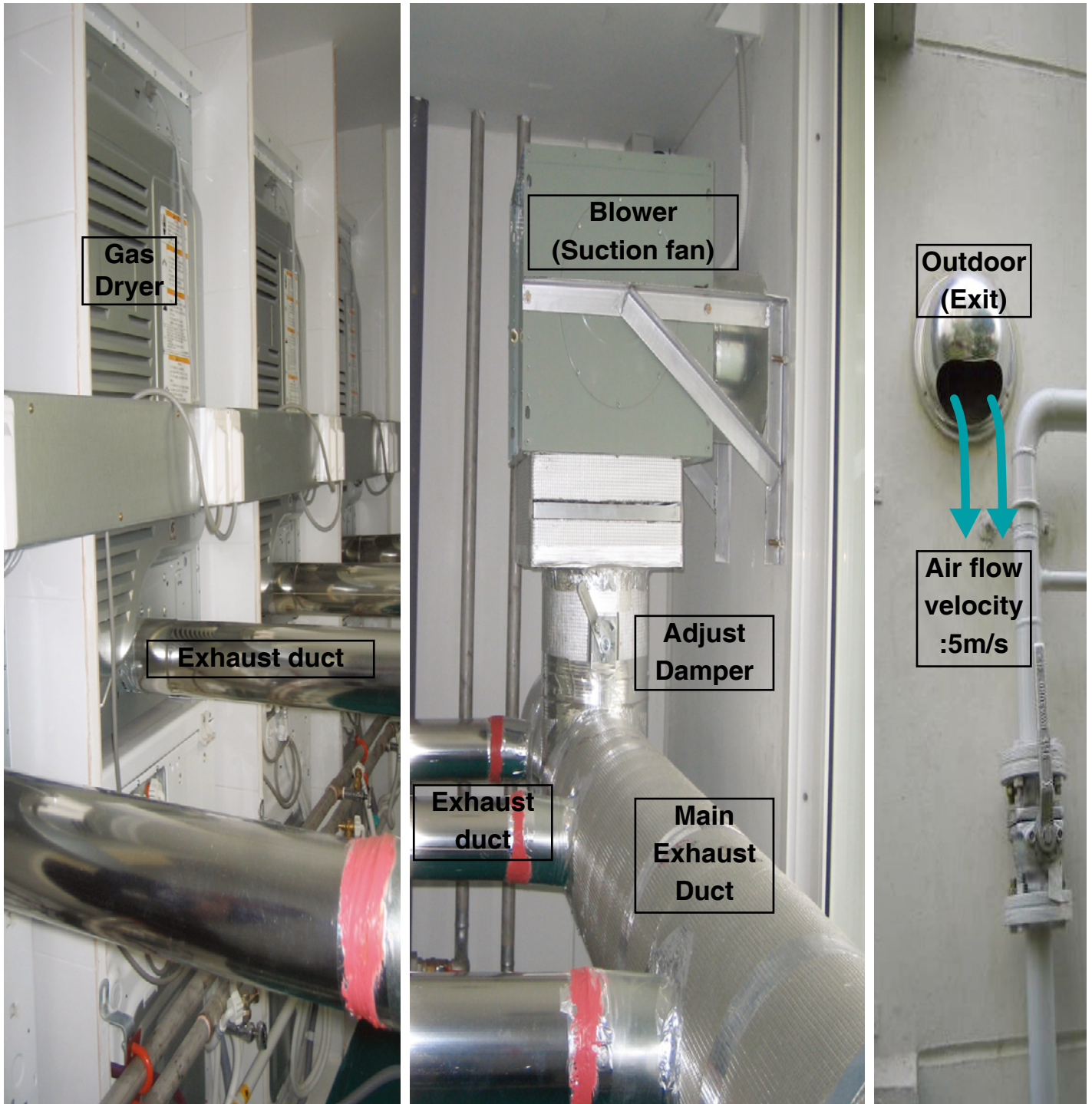

---

## Exhaust and Dryer Maintenance

### **WARNING**

- **Disconnect the dryer's electric power prior to any cleaning or maintenance.**

- Failure to do so can result in fire or electric shock.



1. After one year of use, the interior and complete exhaust system of the dryer should be examined and cleaned if necessary.
2. Before one year of use, when drying performance has become unsatisfactory, please examine and clean the exhaust duct for better drying performance.
3. Check the weather hoods frequently to ensure the dampers are moving freely, that the dampers are not pushed in and that nothing has been set against the dampers.
4. A qualified service person or company should be used to perform this maintenance.
5. A Flexible Metal Vent Kit, available at extra cost, can be used to exhaust the dryer when it is placed in hard to reach places. This Kit comes in two pieces, one of which is attached to the dryer and the other is attached to the wall exhaust outlet. Following attachment of the two separate pieces to the dryer and the wall, the dryer may be returned to its final position, after which the two pieces themselves can be connected.
7. Ordinarily, the dryer drum will need no care. Wipe the exterior of the dryer as required, and always wipe the exterior of the dryer in the event any detergent, bleach, or other washing products is spilled on the dryer.
8. Clean the control panel with a damp cloth as necessary. Warning: spray pre-wash products may damage the finish of the control panel.
9. Please clean the lint filter either before drying each load or after drying each load.
10. Always make sure the lint filter is clean before starting a new load, because a clogged lint filter may increase drying times.
11. Annually remove the lint filter and attach it to the vacuum duct. See item #2 above.
12. Please note that the wiring diagram is provided inside the dryer control hood. Label all wires prior to disconnection when servicing the dryer, because wiring errors can cause serious injury to you and your dryer.

## Cleaning the Lint Screen

1. Clean the lint filter either before drying each load or after drying each load. Always make sure the lint filter is clean before starting a new load, because a clogged lint filter may increase drying times.
2. To clean, pull the lint screen straight up and roll any lint off the screen with your fingers.  
Do not rinse or wash screen to remove lint. Push the lint screen firmly back into place.
3. Always ensure the lint screen is firmly secured before running the dryer. Running the dryer with a loose lint screen may cause overheating and damage to the dryer and articles being dried.
4. Some articles of clothing may shed more lint than others (towels for example), causing the lint screen to fill rapidly. Remove lint from the lint screen before and after drying these articles, such as new towels.
5. In the event lint falls off of the lint screen and into the dryer during removal, inspect the exhaust hood and remove any lint.
6. Laundry detergent and fabric softener residue can build up on the lint screen, causing longer drying times. The screen is likely blocked if lint falls off the screen. In order to prevent this type of build up, and help ensure proper operation of your dryer, clean the lint screen with a nylon brush every six months or, if necessary, more frequently. The lint filter can also be washed as follows:
  - a) After rolling the lint off of the screen with your fingers, wet both sides of the screen with hot or warm water.
  - b) Wet a nylon brush with hot water and liquid detergent and scrub the lint screen with the brush to remove the buildup of detergent and fabric softener.
  - c) After the residue has been removed, rinse screen with hot water.
  - d) After drying the lint screen with a clean towel, firmly replace the lint screen in your dryer.

# 10

## DRYER CYCLE PROCESS

Cycle		Default			Conditions of operation and termination			
		Temperature	Dry Level	Display time	Drying		Cooling	
					Electro-sensor	Temp-Control	Default time	Temp-Control**
Time Dry	High Temp.	HIGH	More Dry	45 min	Saturation	68±4°C	2 min.	47±5°C
	Med Temp.	MEDIUM	More Dry	45 min	Saturation	60±4°C	2 min.	47±5°C
	Low Temp.	LOW	More Dry	45 min	Saturation	52±3°C	2 min.	38±5°C
LOAD		MOTOR			Temperature Control for each cycle 			
		HEATER						

## ⚠ WARNING

- When checking the Component, be sure to turn the power off, and do voltage discharge sufficiently.
- Failure to follow these instructions can result in death or electric shock.

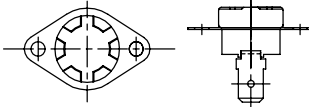
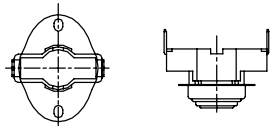
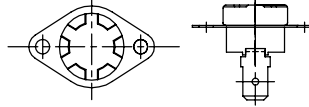
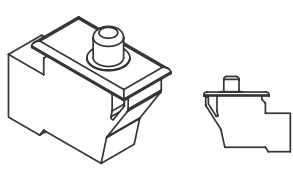
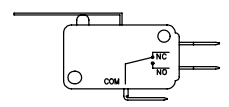
Component	Test Procedure	Check result	Remark
<p>1. Thermal cut off</p>  <p>• Check Top Marking: N130</p>	<p>Measure resistance of terminal to terminal</p> <p>① Open at <math>266 \pm 12^\circ\text{F}</math> (<math>130 \pm 7^\circ\text{C}</math>)</p> <p>② Auto reset <math>31^\circ\text{F}</math> (<math>35^\circ\text{C}</math>)</p> <p>Same shape as Outlet Thermostat.</p>	<p>If thermal fuse is open must be replaced</p> <p>① Resistance value <math>\approx \infty</math></p> <p>② Continuity (<math>250^\circ\text{F} \downarrow</math>) <math>&lt; 1\Omega</math></p>	<ul style="list-style-type: none"> <li>• Heater case-Safety</li> <li>• Electric type</li> </ul>
<p>2. Hi limit Thermostat (Auto reset)</p> 	<p>Measure resistance of terminal to terminal</p> <p>① Open at <math>257 \pm 9^\circ\text{F}</math> (<math>125 \pm 5^\circ\text{C}</math>)</p> <p>② Close at <math>221 \pm 9^\circ\text{F}</math> (<math>105 \pm 5^\circ\text{C}</math>)</p>	<p>① Resistance value <math>\approx \infty</math></p> <p>② Resistance value <math>&lt; 5\Omega</math></p>	<ul style="list-style-type: none"> <li>• Heater case - Hi limit</li> <li>• Electric type</li> </ul>
<p>3. Outlet Thermostat (Auto reset)</p>  <p>• Check Top Marking: N85</p>	<p>Measure resistance of terminal to terminal</p> <p>① Open at <math>185 \pm 9^\circ\text{F}</math> (<math>85 \pm 5^\circ\text{C}</math>)</p> <p>② Close at <math>149 \pm 9^\circ\text{F}</math> (<math>65 \pm 5^\circ\text{C}</math>)</p> <p>Same shape as Thermal cut off.</p>	<p>① Resistance value <math>\approx \infty</math></p> <p>② Resistance value <math>&lt; 5\Omega</math></p>	<ul style="list-style-type: none"> <li>• Blow housing - Safety</li> <li>• Electric type</li> </ul>
<p>5. Door switch</p> 	<p>Measure resistance of the following terminal</p> <p>1) Door switch knob: open</p> <p>① Terminal: COM - NC (1-3)</p> <p>② Terminal: COM - NO (1-2)</p> <p>2) Door switch push: push</p> <p>① Terminal: COM - NC (1-3)</p> <p>② Terminal: COM - NO (1-2)</p>	<p>① Resistance value <math>&lt; 1\Omega</math></p> <p>② Resistance value <math>\approx \infty</math></p> <p>① Resistance value <math>\approx \infty</math></p> <p>② Resistance value <math>&lt; 1\Omega</math></p>	<p>If the knob is pressed, the state is the opposite of what is on the chart.</p>
<p>6. Idler switch</p> 	<p>Measure resistance of the following terminal: COM - NC</p>	<p>1. lever open</p> <p>① Resistance value <math>&lt; 1\Omega</math></p> <p>2. Lever push (close)</p> <p>② Resistance value <math>\approx \infty</math></p>	

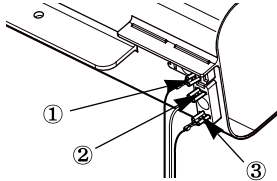
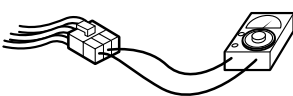
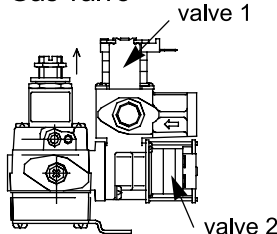
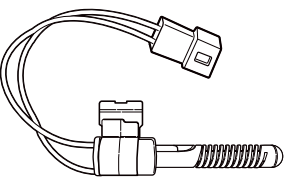
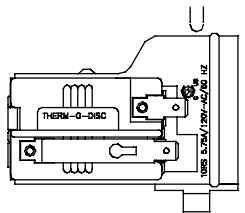
Component	Test Procedure	Check result	Remark
7. Heater 	Measure resistance of the following terminal ① Terminal: 1 (COM) - 2 ② Terminal: 1 (COM) - 3 ③ Terminal: 2 - 3	5400W ① Resistance value 19.2Ω (17.2~21.2Ω) ② Resistance value 19.2Ω (17.2~21.2Ω) ③ Resistance value 38.4Ω (34.4~42.4Ω) 4500W ① Resistance value 24.05Ω (22.05~26.05Ω) ② Resistance value 24.05Ω (22.05~26.05Ω) ③ Resistance value 48.1Ω (44.1~52.1Ω)	<ul style="list-style-type: none"> <li>• Electric type</li> </ul>
8. Thermistor 	Measure resistance of terminal to terminal Temperature condition: 58°F ~ (10~40°C) 58°F ~ 104F (10~40°C)	Resistance value 10Ω	<ul style="list-style-type: none"> <li>• Heater case - Hi limit</li> <li>• Electric type</li> </ul>
9. Motor			<ul style="list-style-type: none"> <li>• See Page 44</li> </ul>
10. Gas valve 	Measure resistance of the following terminal ① Valve 1 terminal ② Valve 2 terminal	① Resistance value > 1.5 kΩ ② Resistance value > 1.5~2.5 kΩ	<ul style="list-style-type: none"> <li>• Gas type</li> </ul>
11. Igniter 	Measure resistance of terminal to terminal	Resistance value 100~800Ω	<ul style="list-style-type: none"> <li>• Gas type</li> </ul>
12. Frame Detect 	Measure resistance of terminal to terminal ① Open at 370°F ((Maximum) ② Close at 320°F	① Resistance value ≒ ∞ ② Resistance value < 1Ω	<ul style="list-style-type: none"> <li>• Gas type</li> </ul>

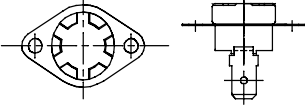
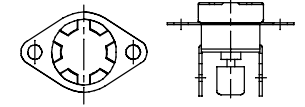
Component	Test Procedure	Check result	Remark
<p>13. Outlet Thermostat (Auto reset)</p>  <ul style="list-style-type: none"> <li>• Check Top Marking: N95</li> </ul>	<p>Measure resistance of terminal to terminal</p> <p>① Open at <math>203 \pm 7^{\circ}\text{F}</math> (<math>95 \pm 5^{\circ}\text{C}</math>)</p> <p>② Close at <math>158 \pm 9^{\circ}\text{F}</math> (<math>70 \pm 5^{\circ}\text{C}</math>)</p>	<p>① Resistance value <math>\neq \infty</math></p> <p>② Continuity <math>&lt; 1\Omega</math></p>	<ul style="list-style-type: none"> <li>• Gas type</li> <li>• Gas funnel</li> </ul>
<p>13. Outlet Thermostat (Manual reset)</p>  <ul style="list-style-type: none"> <li>• Check Top Marking: N100</li> </ul>	<p>Measure resistance of terminal to terminal</p> <p>① Open at <math>212 \pm 12^{\circ}\text{F}</math> (<math>100 \pm 7^{\circ}\text{C}</math>)</p> <p>② Manual reset</p>	<p>If thermal fuse is open must be replaced</p> <p>① Resistance value <math>\neq \infty</math></p> <p>② Continuity <math>&lt; 1\Omega</math></p>	<ul style="list-style-type: none"> <li>• Gas type</li> <li>• Gas funnel</li> </ul>

## ⚠ WARNING

- When checking the component, be sure to turn the power off, and do discharge voltage sufficiently.
- Failure to follow these instructions can result in death or electric shock.

### ■ Contact On / Off by Centrifugal Switch

Terminal No		①	②	③	④	⑤	⑥	Remark
Mode	Resistance							
Motor STOP	2 ~ 3Ω				● — ●			Motor
	≒ ∞	● ..... ●						Heater (Electric Models)
	≒ ∞			● ..... ●				Gas Valve (Gas Models)
Motor RUN	3 ~ 5Ω				● — ●			Motor
	< 1Ω	● — ●						Heater (Electric Models)
	< 1Ω			● — ●				Gas Valve (Gas Models)

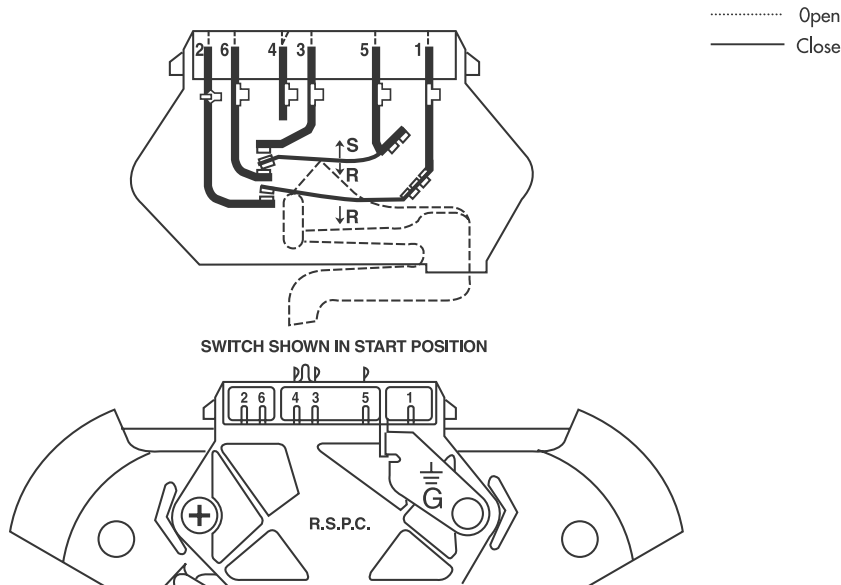

### ■ STOP MODE (When Motor does not operate)

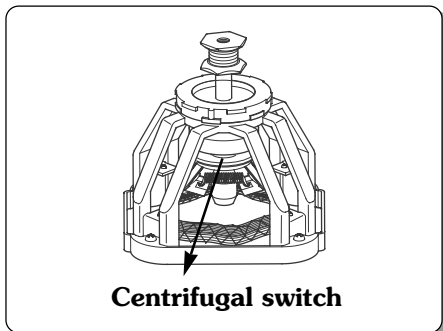

### ■ RUN MODE (Motor operates)

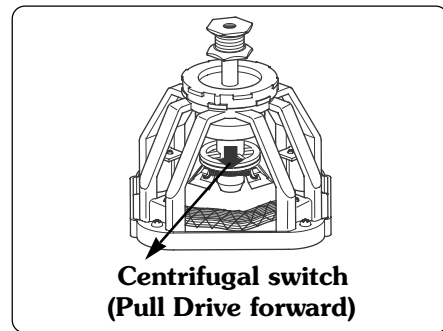

PWB ASSEMBLY DISPLAY LAY-OUT

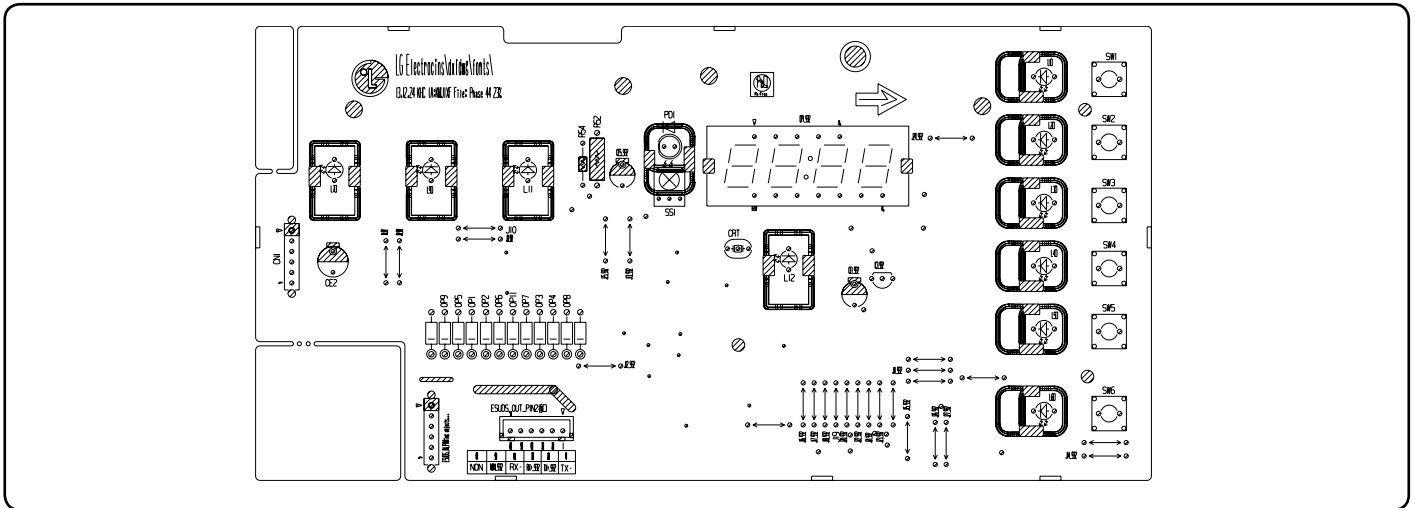

PWB ASSEMBLY LAY-OUT

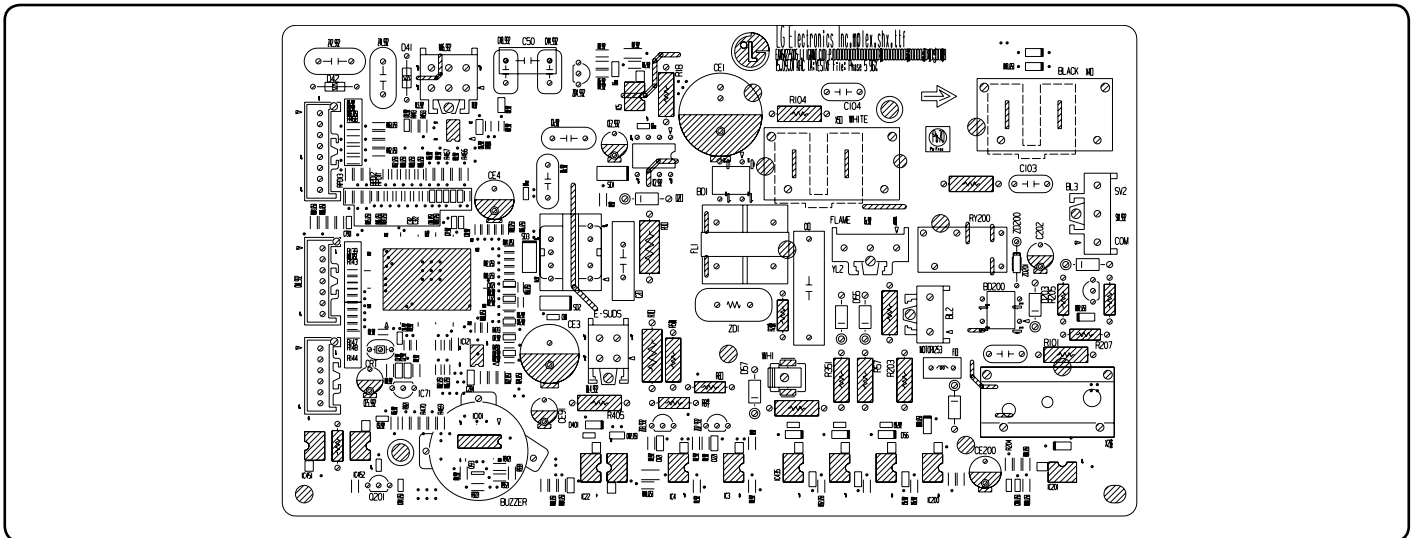

# SPECIFICATIONS

**CAUTION:** Label all wires prior to disconnection when servicing controls. Wiring errors can cause improper and dangerous operation. Verify proper Operation after servicing.

## ELECTRIC DRYER WIRING DIAGRAM

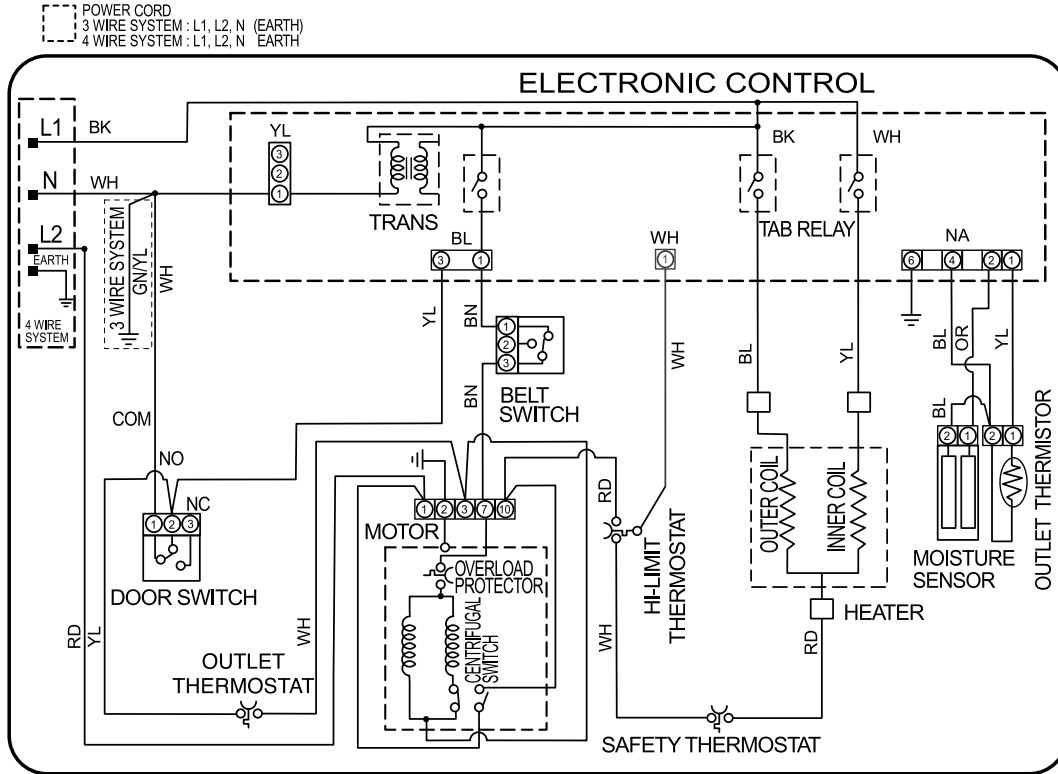

## GAS DRYER WIRING DIAGRAM

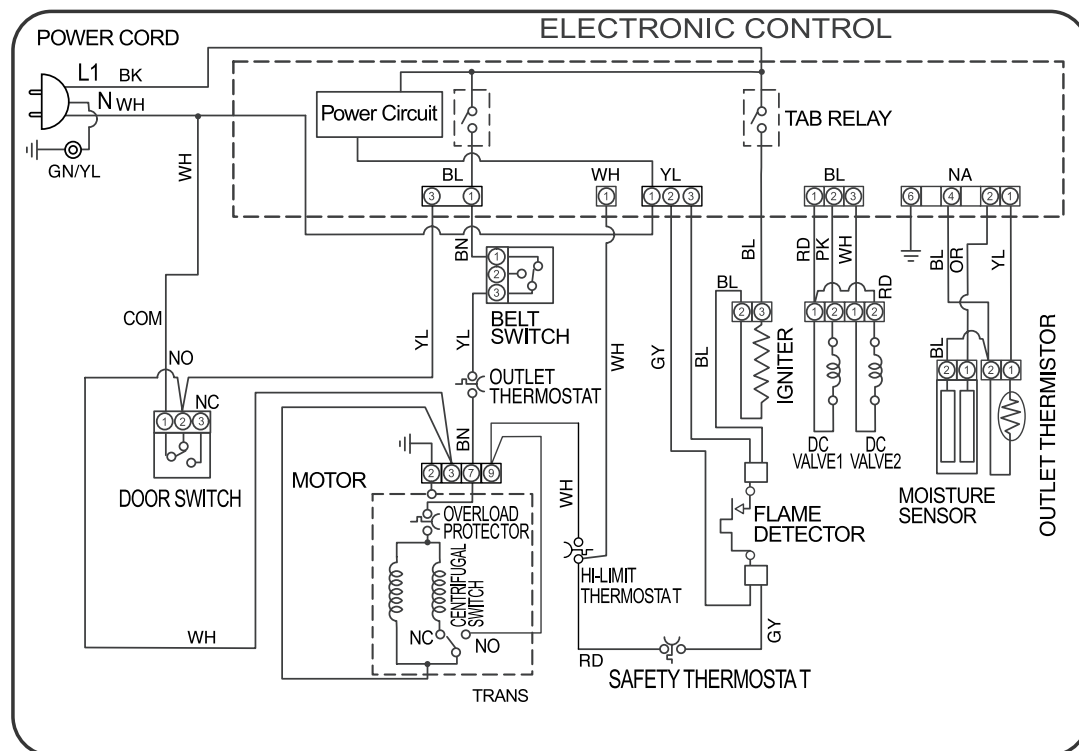

1. This TEST should be used for Factory test /Service test. Do not use this DIAGNOSTIC TEST other than specified.
2. Activating the heater manually with the door open may trip the thermostat attached to the heater, therefore do not activate it manually. (Do not press the door switch to operate the heater while the door is open).

### Diagnostic tests : **8888** (display)

This program has been added for testing the dryer and detecting errors.

#### How to enter Programming mode:

- **Coin type** – Turn on/off the toggle switch.
- **Card type** – Insert the service card.
- **All types** –

- 1) Press the 1st & 3rd button at the same time. **8888**
  - 2) Press the 2nd & 3rd buttons to toggle numbers.
- Then, press the 4th button to move to the next digit. **8888**
- 3) Press the Start button to finish password input. **8888**
- ※ Default Password : 3000

#### <Control Panel >

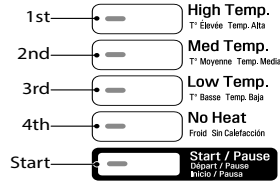

## 2. **8888** Diagnostic Test

Diagnostic Test can be used to check functionality of various machine parts. Press Start to move through the check points.

Number of times the Start button is pressed	Check point	Display
0	Enter SVC mode	<b>8888</b>
1	Check the version and code for machine. <ul style="list-style-type: none"> <li>• Electric Coin type : P2:OE</li> <li>• Electric Card type : P2:OE</li> <li>• Electric OPL type : P2:OE</li> <li>• Gas Coin type : P2:Og</li> <li>• Gas Card type : P2:Cg</li> <li>• Gas OPL type : P2:Pg</li> </ul>	Displays <b>8888</b> , P2:XX, gU:XX, gd:XX and gC:XX alternately (Version)
2	PDA Check	<b>8888</b>
3	Motor runs	Measured moisture value (70~239)
4	<ul style="list-style-type: none"> <li>• Electric type : Heater runs (Motor + Heater 1 (2700W))</li> <li>• Gas Type : Motor runs</li> </ul>	Current temperature (5~70) (Display shows the temperature inside the drum in Celsius)
5	<ul style="list-style-type: none"> <li>• Electric type : Heater runs (Motor + Heater 1+Heater 2 (5400W))</li> <li>• Gas Type : Gas valve runs (Motor +Valve)</li> </ul>	Current temperature (5~70) (Display shows the temperature inside the drum in Celsius)
6	LED&Button Check Press the whole course buttons.	Displays <b>8888</b> , P2:XX, gU:XX, gd:XX and gC:XX alternately (Version)
7	Test Ends	<b>8888</b>
8	Door switch (Motor&Heater Off, Buzzer beeps seven times)	dE (The door is open. Please close the door completely)
9	Test goes back at step 3. (Motor on & Heater Off)	Measured moisture value (70~239)

### ! NOTE

- Make sure the drum is empty when diagnostic test is being performed. Do not use **8888**.

## ■ Test 1 120V AC Electrical Supply

### ⚠ WARNING

- When measuring power, be sure to wear insulated gloves to avoid an electric shock.
- Failure to follow these instructions can result in death or electric shock.

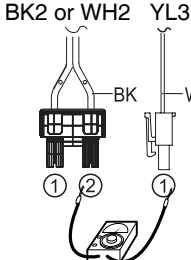
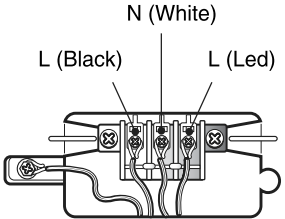
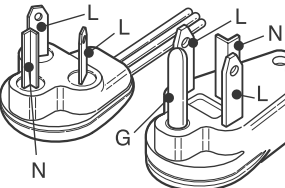
Trouble Symptom	No power was applied to controller. (LED, LCD Display off)	
Measurement Condition	With Dryer Power On; connector linked to controller.	
	<p>Check the outlet, is the voltage 110V ~ 125V AC?</p>	<p><b>NO</b></p> <p>¥Check the fuse or circuit breaker.</p>
<b>YES</b>		
	<p>Check if the voltage measured between Connector BK2 or WH2-② (Black Wire) Linked to the Controller and YL3-① (White Wire) Is 110~125V?</p>	<p><b>NO</b></p> <p>¥Check if power cord is properly connected.</p>
<b>YES</b>		
	<p>① Check if the controller wire is disconnected.                  ② Check if terminal block and power cord are connected (Check Plug).                  - Does Power Cord N (Natural) line match to Terminal Center N (Natural) line?</p>	<p><b>NO</b></p> <p>¥Reconnect the controller.</p>
<b>YES</b>		
	<p>Replace controller.</p>	

## ⚠ WARNING

- When measuring power, be sure to wear insulated gloves, to and avoid an electric shock.
- Failure to follow these instructions can result in death or electric shock.

Trouble Symptom	Check the Tab Relays Connection properly.
Measurement Condition	With Dryer Power On; Connector linked to Controller.

### 1. Power Connection

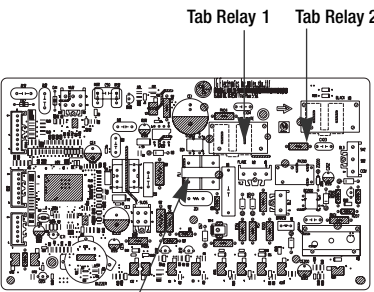

● PCB ASSEMBLY LAYOUT

**Table1 : Connection of the Tab Relay with Heater (Electric)**

	Tab Relay 1	Tab Relay 2	Heater 1	Heater 2	Remark
High Mid High Medium	on	on	on	on	Temperature Control below $68 \pm 4^\circ\text{C}$ . Turn on Heater1 and Heater2.
Low Extra Low	on	off	on	off	Temperature Control below $52 \pm 4^\circ\text{C}$ . Only Turn on Heater1.

**Table 2 : Connection of the Tab Relay with Burner (Gas)**

	Tab Relay 1	Burner	Remark
High Mid High Medium	○	○	Temperature Control below $70 \pm 4^\circ\text{C}$ . Turn on Burner
Low Extra Low	○	○	Temperature Control below $47 \pm 4^\circ\text{C}$ . Turn on Burner

### 2. Status Mode Of The Connection

**Table1 : Connection of Tab Relay with the Tab Relay of the PCB ASSEMBLY (Electric)**

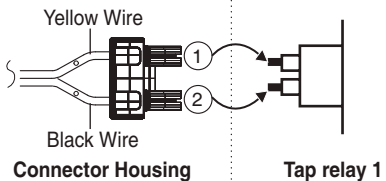
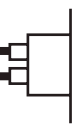
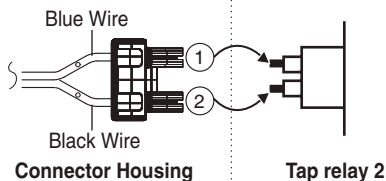
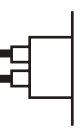
	Color	Connection		Remark
		Harness	PCB	
Connector Housing	Black			Check the matching color between harness wire and tab relay. (Black Housing – Black Tab Relay)
	White			Check the matching color between harness wire and tab relay. (White Housing – White Tab Relay)

**Table 2 : Connection of Tab Relay with PCB ASSEMBLY (Gas)**

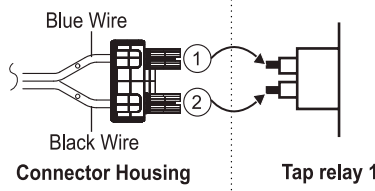
	Color	Harness	PCB	Remark
Connector Housing	Black			Check the matching color between harness wire and tab relay. (Black Housing – Black Tab Relay)

**3. Status Mode Of wrong Connection**

**Table1: Wrong Connection of the Tab Relay and Connector Housing (Electric)**

Items	Case	Heater1 operation (black)	Heater2 operation (white)	PCB condition of operation
1. Black and White Housing	Wire ①, ② CROSS	Off	Off	Power Off
2. Black Housing	Wire ①, ② CROSS	Off	Off	Power Off
3. White Housing	Wire ①, ② CROSS	Normal	Normal	Power On
4. Black and White Housing	Housing CROSS	Heater2	Heater1	Power On
5. Black and White Housing	Housing and Wire ①, ② CROSS	Off	Off	Power Off

**Table2 : Wrong Connection of the Tab Relay and Connector Housing (Gas)**

Items	Case	Heater1 operation(black)	Heater2 operation(White)	PCB condition of operation
1. Black and White Housing	Wire ①, ② CROSS	Off	Off	Power Off

**⚠ WARNING**

- In case of power failure(Table1-1,2,5,Table2-1), Please check the connection of 2. Status Table of Connection.
- In case of power failure(Table1-4), please check the Connection of 2. Status Table of Connection because improper connection of the equipment-dryer can be damaged of changing heater.

## ■ Test 2 Thermistor Test --- Measure with Power Off

### ▲ WARNING

- Before measuring resistance, be sure to turn power off, and do voltage discharge. (When discharging, contact the metal plug of power cord with the ground.)
- Failure to follow these instructions can result in death or electric shock.

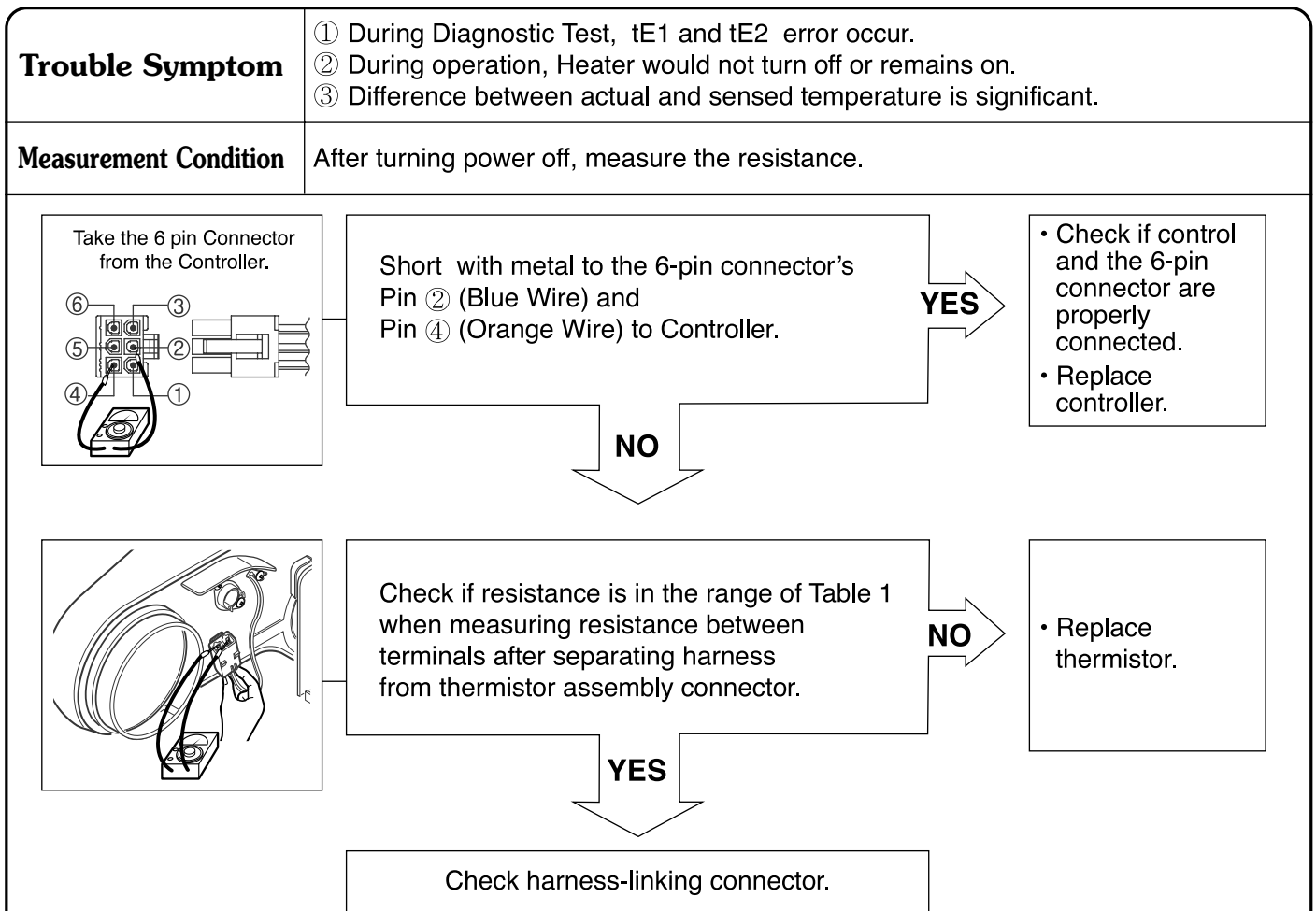

■ Table 1. Resistance for Thermistor Temperature.

Air TEMP. °F(°C)	RES. kΩ	Air TEMP. °F(°C)	RES. kΩ	Air TEMP. °F(°C)	RES. kΩ
50°F (10°C)	18.0	90°F (32°C)	7.7	130°F (54°C)	2.9
60°F (16°C)	14.2	100°F (38°C)	6.2	140°F (60°C)	3.0
70°F (21°C)	11.7	110°F (43°C)	5.2	150°F (66°C)	2.5
80°F (27°C)	9.3	120°F (49°C)	4.3	160°F (71°C)	2.2

## ■ Test 3 Motor Test

### ⚠ WARNING

- Before measuring resistance, be sure to turn power off, and do voltage discharge. (When discharging, contact the metal plug of power cord with the earth line.)
- Failure to follow these instructions can result in death or electric shock.

<b>Trouble Symptom</b>	Drum does not turn, fan does not blow, and heater does not operate.	
<b>Measurement Condition</b>	Turn the dryer's power off, then measure resistance.	
	Is resistance below 3% between connector YL3- ① (White wire) and BL2- ② (Brown wire)? ※ Measure while door is closed.	YES → • Replace control. (Relay check) • Check controller connector.
	Is resistance below 3% between Connector YL3- ① (White wire) and BL2- ② Measure while door is closed. (Yellow wire)?	NO → • Check if door frame presses door switch knob. • Check door switch. • Check harness connection.
	Is resistance below 3% between Connector BL2- ① (Yellow wire) and BL2- ② (Brown wire)?	YES → • Replace control. (Relay check) • Check controller connector.
	Is resistance below 1% between terminals of outlet thermostat attached to blower housing?	NO → • Replace outlet • Thermostat. (Refer to component)
	Does idler switch attached to motor bracket operate level by drum belt? (Not operating lever is normal.)	YES → • Check idler assembly • Drum belt cuts off • Drum belt takes off from motor pulley.
	Is resistance below 1% between idler switch terminals?	NO → • Replace idler switch.
	YES → ¥ Check motor. (Refer to Motor Diagram and Check) ¥ Check if control connector is contacted.	

## ■ Test 4 Moisture Sensor

### ⚠ WARNING

- Before measuring resistance, be sure to turn power off, and do voltage discharge. (When discharging, contact the metal plug of power cord with the earth line.)
- Failure to follow these instructions can result in death or electric shock.

#### Trouble Symptom

Degree of dryness does not match with dry level.

#### Measurement Condition

Turn the dryer's power off, then measure resistance.

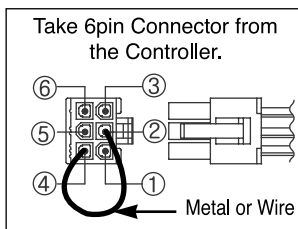

Short with metal to the 6 pin connector's pin ② (Blue Wire) and Pin ④ (Orange Wire) to controller.

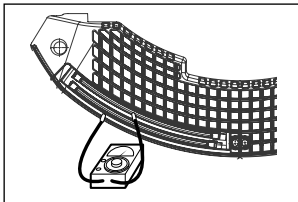

When measuring resistance in electrode load, is resistance below 1Ω?

NO

- Check electrode and harness connector.
- Check harness-linking connector.

YES

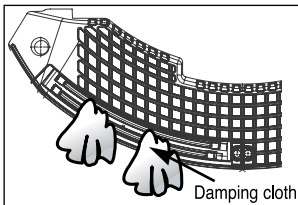

When contacting cloth to electrode:  
 1. Is the measurement within the range of Table 2 during diagnostic test?  
 2. Is the measurement within the range of Table 2 when measuring the voltage in the 6 pin connector's Pin ③ (BLUE wire) and Pin ⑤ (ORANGE wire)?

NO

- Replace control and check.

YES

Normal Condition

■ Table 2. IMC Ratio and Display Value / Voltage (IMC: Initial Moisture Content)

IMC	Display Value	Voltage (DC) (between 6 Pin terminal ③,⑤)	Remark
70% ~ 40%	50 ~ 130	2.5V	Weight after removing from washing machine
40% ~ 20%	130 ~ 20	2.0V ~ 4.0V	Damp Dry
10% ~ dried clothes	205 ~ 240	Over 4.0V	Completely-dried clothes

## ■ Test 5 Door switch test

### ⚠ WARNING

- Before measuring resistance, be sure to turn power off, and do voltage discharge. (When discharging, contact the metal plug of power cord with the earth line.)
- Failure to follow these instructions can result in death or electric shock.

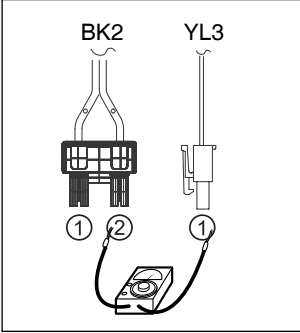
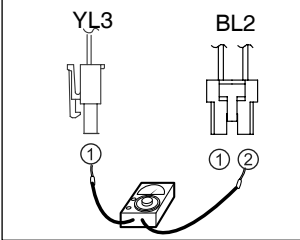
<b>Trouble Symptom</b>	Door opening is not sensed. (During operation, when opening door, drum motor and Heater run continuously) Door close is not sensed. (Drum motor will not operate. Display will flash at 1/	
<b>Measurement Condition</b>	Turn the dryer's power off, then measure resistance.	
	<p>Measure while door is closed. Check it resistance is below 2500 % between YL3-① (White wire) and BK2-② Connector YL3,BL2 after taking WH1,BL2 out from Controller.</p> <p style="text-align: right;"><b>YES</b> →</p> <p style="text-align: center;"><b>NO</b> ↓</p> <p>Measure while door is open. Check it resistance is 300~60 % between YL3-① (White wire) and BK2-② (Black wire). Connector YL3,BL2 after taking YL3,BL2 out from controller.</p> <p style="text-align: right;"><b>NO</b> →</p> <p style="text-align: center;"><b>YES</b> ↓</p>	<ul style="list-style-type: none"> <li>• Door switch check (Refer to component testing.)</li> <li>• Check lamp. (When opening lamp, replace then measure again.)</li> <li>• Door switch check (Refer to component testing.)</li> </ul>
	<p>Measure while door is open. Check it resistance is below 1 % between BL2-① (Yellow wire) and YL3-① (White wire) after taking connector YL3,BL2 out from controller.</p> <p style="text-align: right;"><b>YES</b> →</p> <p style="text-align: center;"><b>NO</b> ↓</p>	<ul style="list-style-type: none"> <li>• Door switch check (Refer to component testing.)</li> </ul>
	<p>Measure while door is closed. Check it resistance is below 1 % between BL2-① (Yellow wire) and YL3-① (White wire) after taking connector YL3,BL2 out from controller.</p> <p style="text-align: right;"><b>NO</b> →</p> <p style="text-align: center;"><b>YES</b> ↓</p> <p style="text-align: center;">Check hontroller. Check harness-linking connector.</p>	<ul style="list-style-type: none"> <li>• Door switch check (Refer to component testing.)</li> </ul>

## ■ Test 6 Heater switch test - Electric Type

### ▲ WARNING

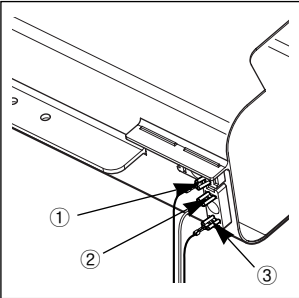
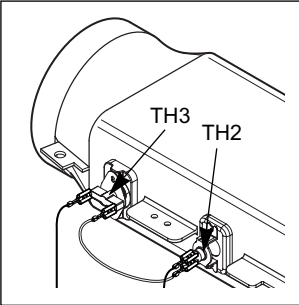

- Before measuring resistance, be sure to turn power off, and do voltage discharge. (When discharging, contact the metal plug of power cord with the ground)
- Failure to follow these instructions can result in death or electric shock.

Trouble Symptom	While operating, heating will not work. Drying time takes longer.	
Measurement Condition	After turning power off, measure the resistance.	
	<p>5400W</p> <p>① Resistance value 17.2~21.2Ω</p> <p>② Resistance value 17.2~21.2Ω</p> <p>③ Resistance value 34.4~42.4Ω</p> <p>4500W</p> <p>① Resistance value 22.05~26.05Ω</p> <p>② Resistance value 22.05~26.05Ω</p> <p>③ Resistance value 44.1~52.1Ω</p>	<p><b>NO</b></p> <p>• Replace heater.</p>
	<p>Check if the value of measured resistance is below 1Ω between terminal TH2 (Safety Thermostat).</p>	<p><b>NO</b></p> <p>• Replace TH2 (Safety Thermostat).</p>
	<p>Check if the value of measured resistance is below 1Ω between terminal TH3 (HI-Limit Thermostat).</p>	<p><b>NO</b></p> <p>• Replace TH3 (HI-Limit Thermostat).</p>
	<p>Check motor. Check if the value of measured resistance is below 1Ω between terminal ① and ⑩ at RUN condition.</p>	<p><b>NO</b></p> <p>• Check motor and replace it.</p>
<p>Check controller. Check harness-linking connector.</p>		

## ■ Test 7 GAS valve test - Gas Type

### ▲ WARNING

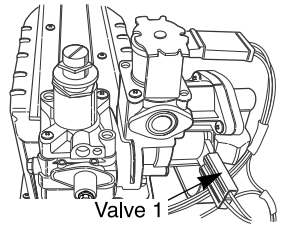
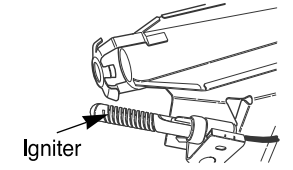
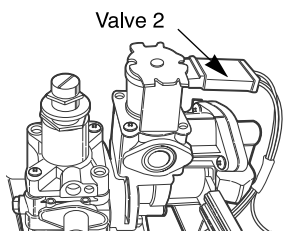
- When measuring power, be sure to wear insulated gloves to avoid an electric shock.
- Failure to follow these instructions can result in death or electric shock.

<b>Trouble Symptom</b>	While operating, heating will not work. Drying time takes longer.	
<b>Measurement Condition</b>	With dryer power on	
	<p>Power on &amp; start (Normal Cycle)</p> <p style="text-align: center;"><b>NO</b></p>	
	<p>When measuring Valve 1 voltage, More than DC 90V?</p> <p style="text-align: right;"><b>NO</b></p> <p style="text-align: center;"><b>YES</b></p>	<p>• Check thermostat Hi limit Safety</p>
	<p>Igniter operates? (after 1 minute, igniter becomes reddish)</p> <p style="text-align: right;"><b>NO</b></p> <p style="text-align: center;"><b>YES</b></p>	<p>• Check igniter &amp; flame detect</p>
	<p>When measuring Valve 2 voltage, Value is more than DC 90V? (10 sec after Igniter off)</p> <p style="text-align: right;"><b>YES</b></p> <p style="text-align: center;"><b>NO</b></p>	<p>• Check gas connection or gas supply</p>
	<p>When measuring terminal resistance on Valve 1 and Valve 2, valves are more than 1.5 ~ 2.5kΩ? (Measure after off)</p> <p style="text-align: right;"><b>YES</b></p> <p style="text-align: center;"><b>NO</b></p>	<p>• Change valve</p>
	<p>If valve 1 and Valve 2 are under DC 10V, valves are off?</p> <p style="text-align: right;"><b>NO</b></p> <p style="text-align: center;"><b>YES</b></p>	<p>• Change valve</p>
	<p>• Harness check • Controller change</p>	

## Dryer error code

PROBLEM	POSSIBLE CAUSE	SOLUTION
<i>EE1</i>	It is displayed when thermistor is opened or shorted	Thermistor should be replaced.
<i>EE2</i>	ELECTRIC TYPE It is displayed when thermistor temperature have increased about 5 degrees for 3 seconds GAS TYPE It is displayed when thermistor temperature have increased about 17 degrees for 10 seconds	Thermistor should be replaced.
<i>CAE</i>	Disconnection of card reader wire.	Check the card reader wire.
<i>nE</i>	Wi-Fi module is disconnected or broken.	Check the Wi-Fi module or replace it.
<i>nF</i>	No Wi-Fi signal or is not registered with machine.	Check the Wi-Fi signal.

## LG Laundry Lounge (Smart Solution)

### Checking and choosing the proper location

This is the remote monitoring and control system.  
There are three components as follows.

- 1) LG Laundry Lounge Installer(App) : This is a registration app for installers used to register the product on the server. Only available for authorized users.  
\* Search for LG Laundry Lounge Installer in Google Play Store or Apple App Store.
- 2) LG Laundry Lounge(App) : This is an end-user app used to check real-time status of registered stores and products.  
\*Search for LG Laundry Lounge in Google PlayStore or Apple App Store.
- 3) LG Laundry Lounge(Web) : This is an administrator website where you can remotely monitor and control registered locations and products. Please access the website address below.  
<https://cls.lgthing.com>

### How to register the product

- 1) Run the LG Laundry Lounge Installer application on a smartphone.
- 2) Create an account and Sign-in.
- 3) Add Location  
(Input information : Location Name, Address, E-mail, Phone Number)
- 3) Add Location  
(Input information : Location Name, Address, E-mail, Phone Number)
  - A unique Location PIN number is generated after 'Add Location.' This is used when the end-user registers the location. Share the Location PIN Number for the end-user.
  - You can check the Location PIN number under the location name (Six-digit number).
- 4) Add a Device
  - Shift the product to Soft Access Point (AP) mode.  
Press and hold the top three course buttons (see image below).



You will see **2.E9** on the machine display.  
The device functions as an AP and sends out a wireless signal.

- Pairing the product to the App :
  - a) Android : Product will automatically pair with the App.  
Skip to the next step.
  - b) iOS : Turn on Wi-Fi settings, then connect to the product's network (shown below),  
If required, enter the following :

Network name	Password
Washer : LG_Smart_Laundry2_XXXX	Enter XXXX twice (Case - sensitive)
Dryer :LG_Smart_Dryer2_XXXX	

After connecting, return to the LG Laundry Lounge Installer App.

- The application shows the Wi-Fi network list.  
Select the Wi-Fi network you wish to use.  
If your network requires a key, enter the password and press the Connect button.
- ※ 5GHz networks may not be supported.
- ※ Make sure the Wi-Fi network name does not contain non-English or special characters.
- The application now works to connect the product and register it as a Wi-Fi product.
- When the connection is completed, the product goes to standby mode automatically.
- When the product registration is completed, you can see the product for the installation location.
- ※ If you see Error next to the nickname of the product, please delete and re-register. Also, check the router signal strength.

## Wireless LAN Module Specifications

<b>Model</b>	LCW-004
<b>Frequency Range</b>	2412 - 2462 MHz
<b>Output Power (Max)</b>	< 30 dBm

### FCC Notice

This equipment has been tested and found to comply with the limits for a Class B digital device, pursuant to Part 15 of the FCC Rules. These limits are designed to provide reasonable protection against harmful interference in a residential installation. This equipment generates, uses, and can radiate radio frequency energy and, if not installed and used in accordance with the instructions, may cause harmful interference to radio communications. However, there is no guarantee that interference will not occur in a particular installation. If this equipment does cause harmful interference to radio or television reception, which can be determined by turning the equipment off and on, the user is encouraged to try to correct the interference by one or more of the following measures:

- Reorient or relocate the receiving antenna.
- Increase the separation between the equipment and the receiver.
- Connect the equipment to an outlet on a circuit different from that to which the receiver is connected.
- Consult the dealer or an experienced radio/TV technician for help.

This device complies with part 15 of the FCC Rules. Operation is subject to the following two conditions:

- 1) This device may not cause harmful interference and
- 2) This device must accept any interference received, including interference that may cause undesired operation of the device.

Any changes or modifications in construction of this device which are not expressly approved by the party responsible for compliance could void the user's authority to operate the equipment.

### FCC RF Radiation Exposure Statement

This equipment complies with FCC radiation exposure limits set forth for an uncontrolled environment. This transmitter must not be co-located or operating in conjunction with any other antenna or transmitter.

This equipment should be installed and operated with a minimum distance of 20 cm (7.8 inches) between the antenna and your body. Users must follow the specific operating instructions for satisfying RF exposure compliance.

### Industry Canada Statement (For transmitter module contained in this product)

This device contains licence-exempt transmitter(s)/ receiver(s) that comply with Innovation, Science and Economic Development Canada's licence-exempt RSS(s).

Operation is subject to the following two conditions:

- 1) This device may not cause interference.
- 2) This device must accept any interference, including interference that may cause undesired operation of the device.

### IC Radiation Exposure Statement

This equipment complies with IC radiation exposure limits set forth for an uncontrolled environment.

This equipment should be installed and operated with a minimum distance of 20 cm (7.8 inches) between the antenna and your body.

### ! NOTE

THE MANUFACTURER IS NOT RESPONSIBLE FOR ANY RADIO OR TV INTERFERENCE CAUSED BY UNAUTHORIZED MODIFICATIONS TO THIS EQUIPMENT. SUCH MODIFICATIONS COULD VOID THE USER'S AUTHORITY TO OPERATE THE EQUIPMENT.

### Open Source Software Notice Information

To obtain the source code under GPL, LGPL, MPL, and other open source licenses, that is contained in this product, please visit <http://opensource.lge.com>. In addition to the source code, all referred license terms, warranty disclaimers and copyright notices are available for download.

LG Electronics will also provide open source code to you on CD-ROM for a charge covering the cost of performing such distribution (such as the cost of media, shipping, and handling) upon email request to [opensource@lge.com](mailto:opensource@lge.com). This offer is valid for three (3) years from the date on which you purchased the product.

## ▲ WARNING

- Conversion must be made by a qualified technician.
- Changing orifices and gas valve adjustments improperly can result in an explosion and/or fire.

### Note

The dryer is shipped from the factory set up and adjusted to operate on natural gas. It can be converted to operate on propane (LPG). The conversion kit may be sold only to a licensed gasfitter, and must be performed ONLY by a licensed gasfitter. This is not a do-it-yourself.

## STEP 1 : VALVE SETTING

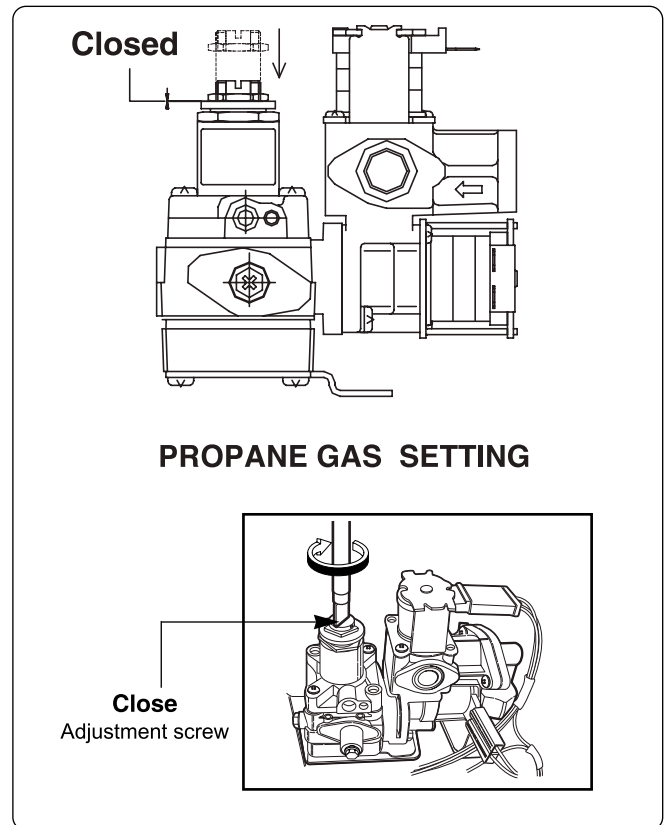
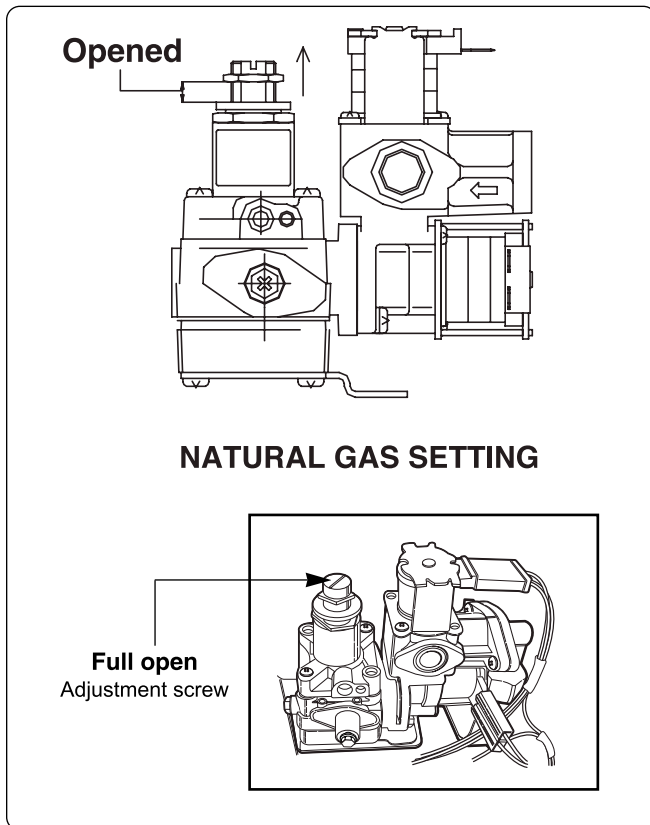

## STEP 2 : ORIFICE CHANGE

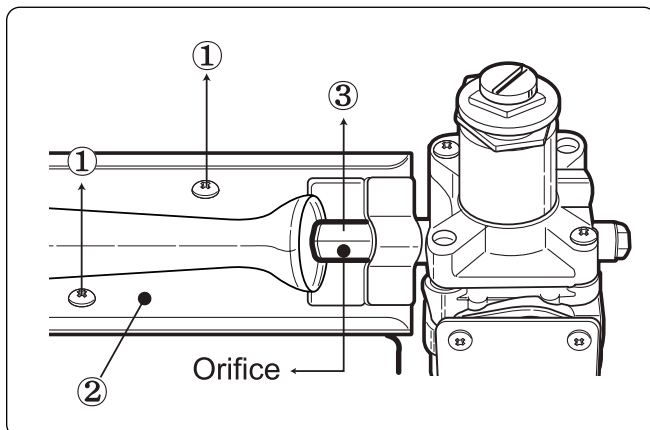

- ① Remove 2 screws.
- ② Disassemble the pipe assembly.
- ③ Replace natural gas orifice with propane gas orifice.

Gas type	Orifice P/No	Marking	Shape
<b>Natural Gas</b>	4948EL4001B	NCU	
<b>Propane Gas</b>	4948EL4002B	PCU	

※ **Kit contents:** Orifice (Dia. = 1.613mm, for Propane Gas)  
Replace Label  
Instruction Sheet

## ■ GAS VALVE FLOW

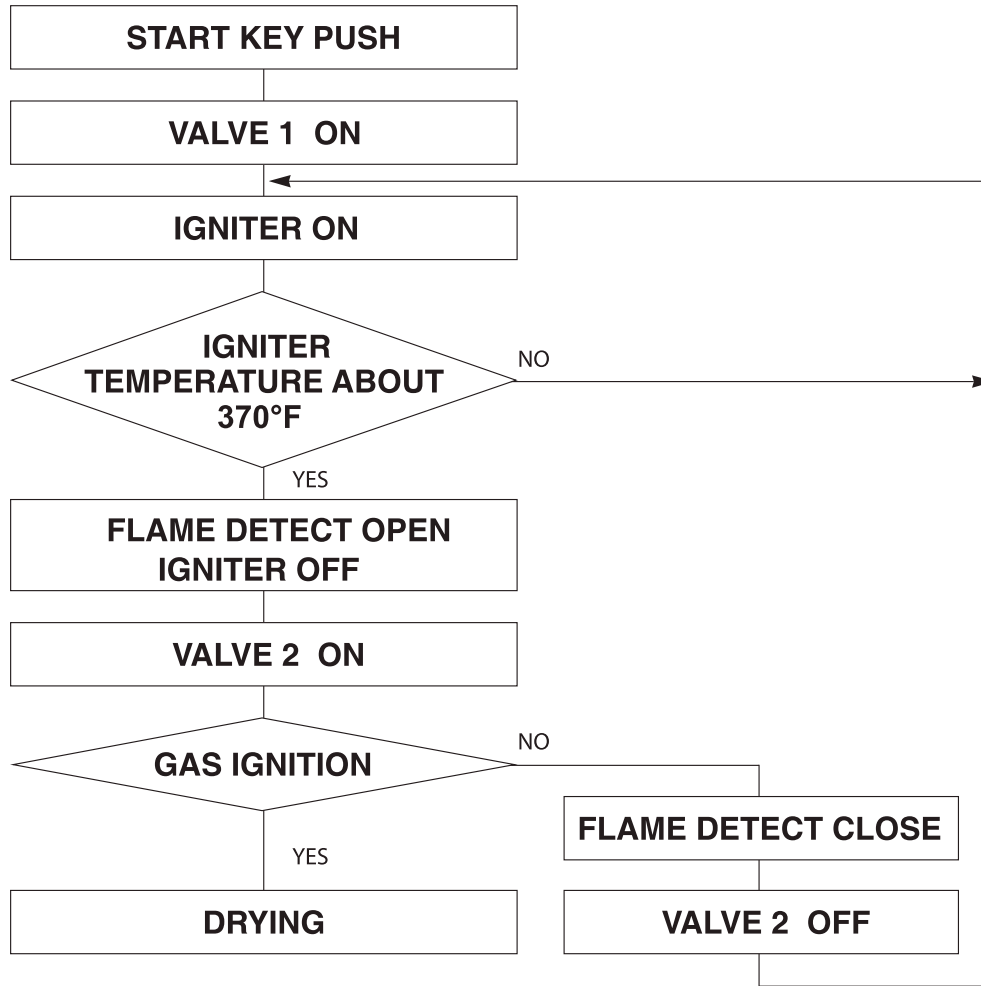

### GAS IGNITION

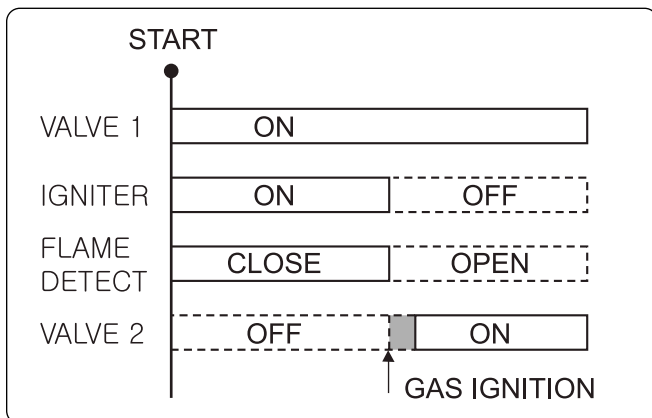

### GAS VALVE STRUCTURE

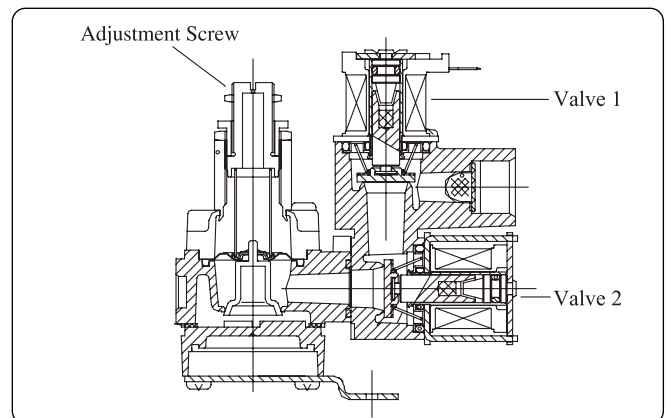

**⚠ WARNING**

- Disassemble and repair the unit only after pulling out power plug from the outlet.
- Failure to follow these instructions can result in death or electric shock.

## CONTROL PANEL ASSEMBLY

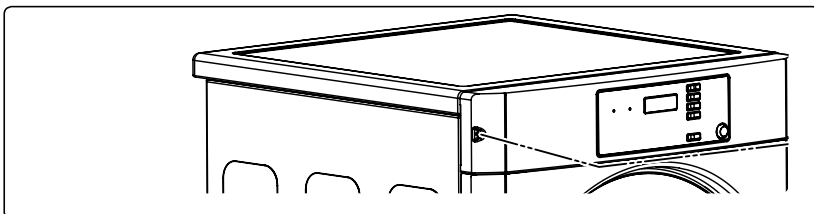
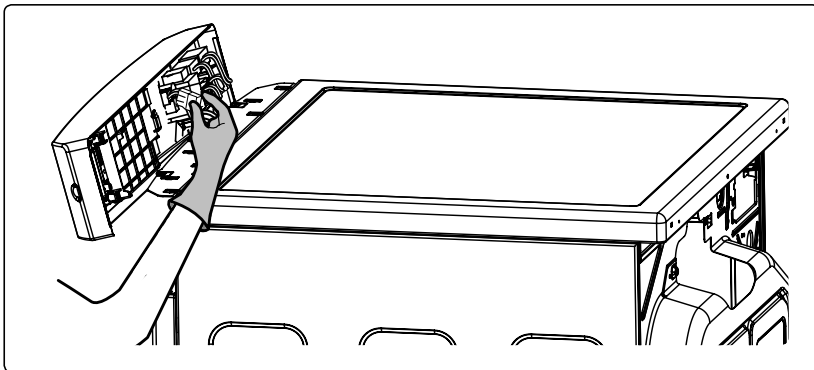
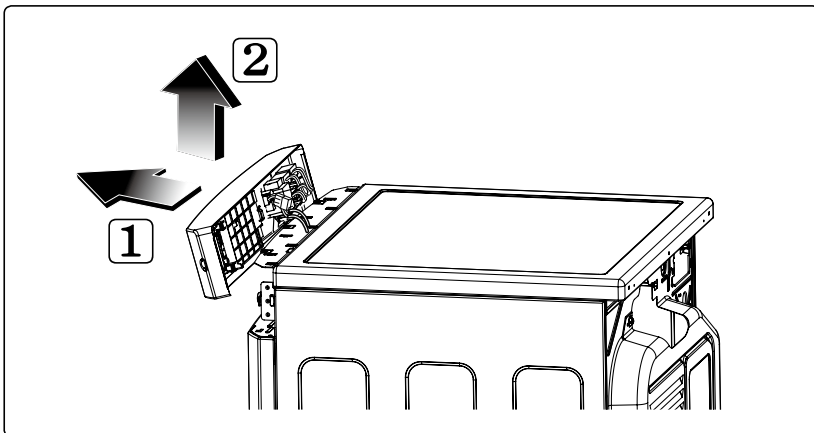
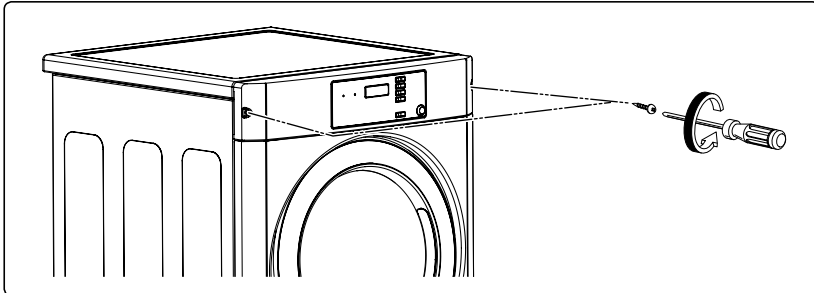
**⚠ WARNING**

- When you disassemble the control panel, be sure to take gloves and careful panel frame's edge. Failure to do so can cause serious injury.

1. Remove 2 screws on the control panel assembly.

2. Pull the control panel assembly upward and then forward.

3. Disconnect the connectors.

## TOP PLATE

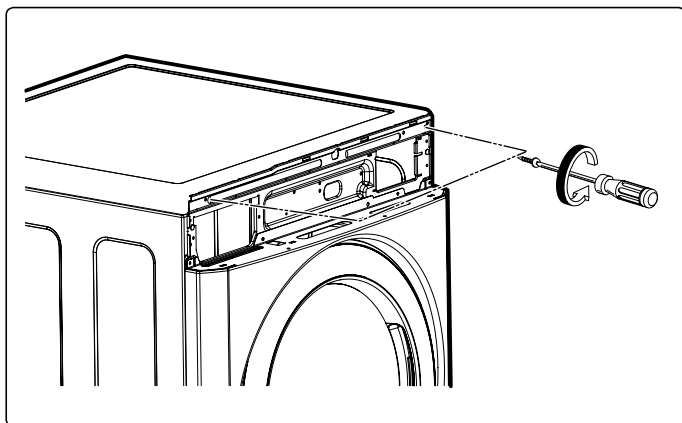

### **⚠ WARNING**

- When you disassemble the top plate, be sure to take gloves and careful plate's edge. Failure to do so can cause serious injury.

1. Remove 2 screws on the control panel frame.

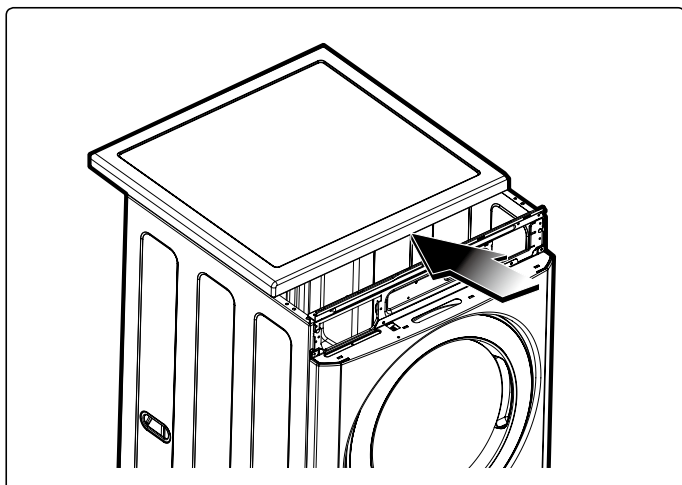

2. Push the top plate backward forcefully.

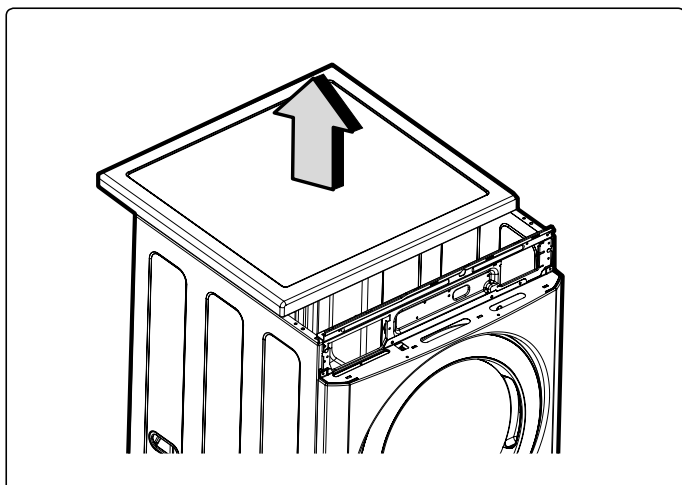

3. Lift the plate.

## LOWER COVER

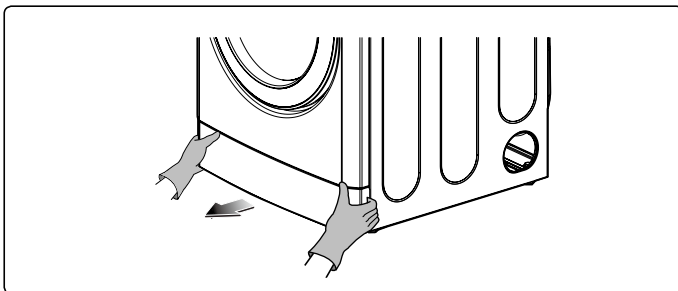
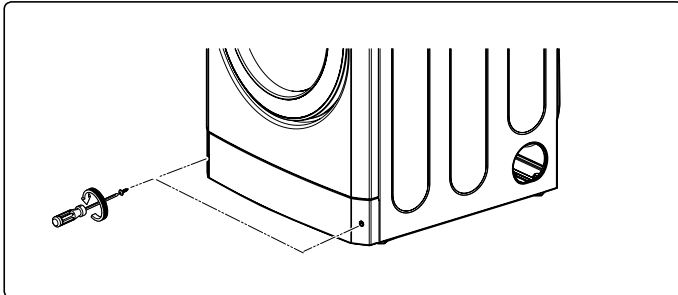

1. Remove 2 screw on the lower cover.
2. Take out of the lower cover.

## COVER CABINET

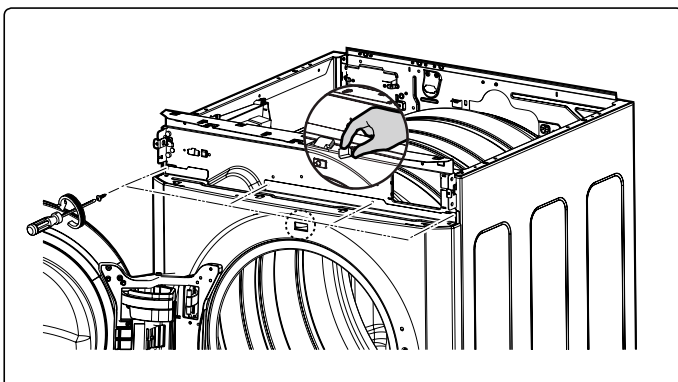
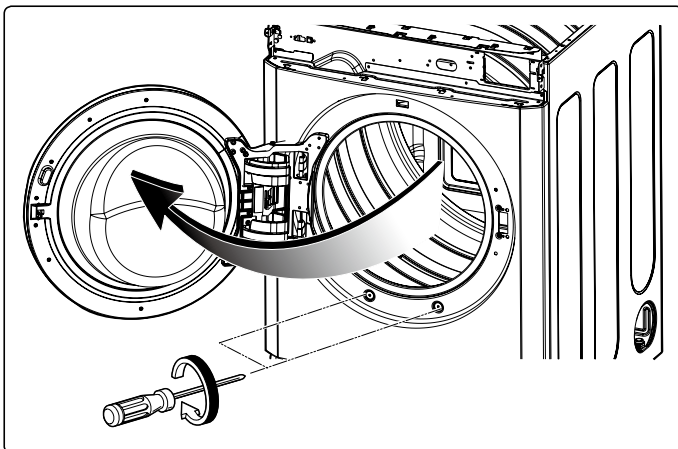

### **⚠ WARNING**

- When you disassemble the door switch connector, be sure to take gloves and careful cabinet edge. Failure to do so can cause serious injury.

1. Open the door assembly.
2. Remove 2 screws.
3. Remove 4 screws from the top of cabinet cover.
4. Disconnect the harness of door switch.
5. Disassemble the cover cabinet.

## PANEL FRAME

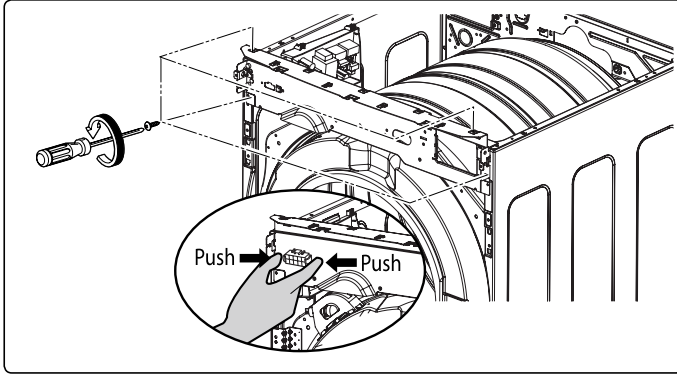

1. Disconnect the housing of the panel frame.
2. Remove 4 screws on the panel frame.
3. Disassemble panel frame from pulling upside.

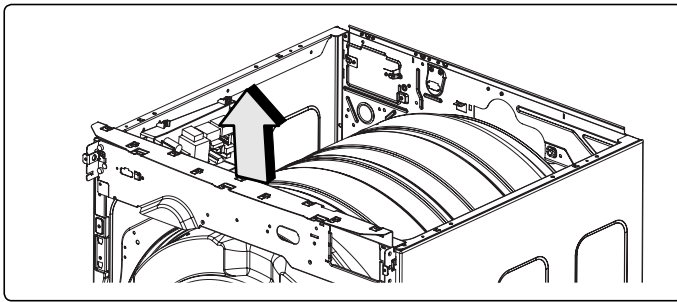

## LOWER FRAME

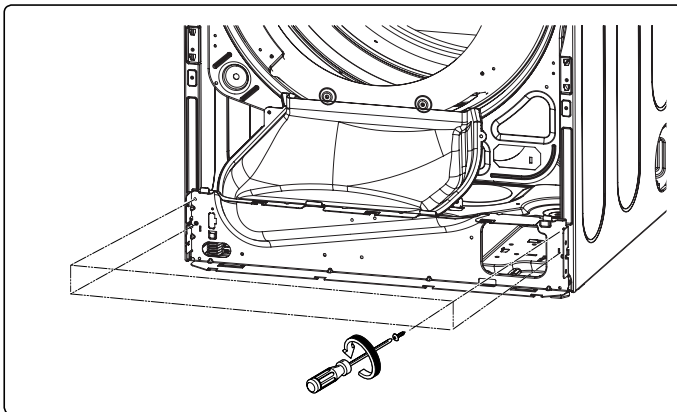

1. Disconnect the housing of the panel frame.
2. Remove 4 screw on the panel frame.
3. Disassemble lower frame from pulling forward with pushing down.

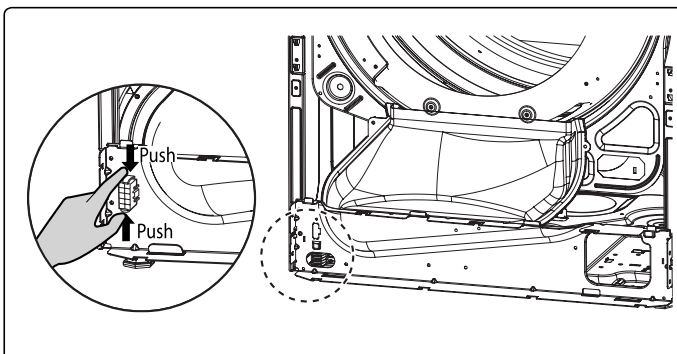

## TUB DRUM [FRONT]

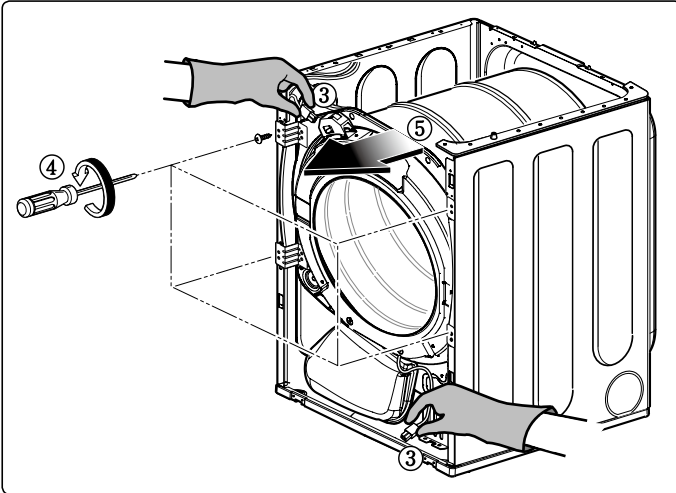

1. Disassemble the top plate.
2. Remove cover cabinet.
3. Disconnect the door lamp and electrode sensor connector.
4. Remove 4 screws.
5. Disassemble the tub drum front.

## DRUM ASSEMBLY

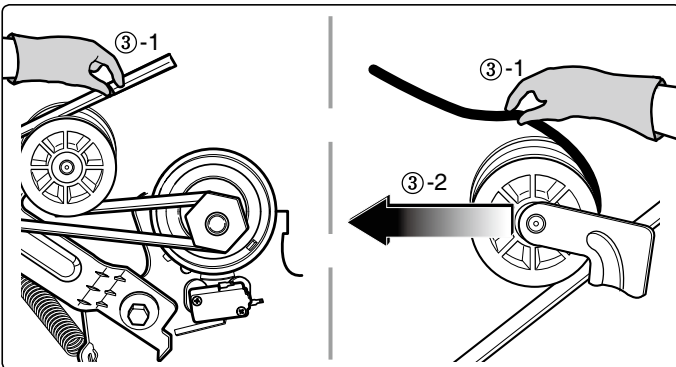

1. Disassemble the top plate.
2. Remove the cabinet cover and drum front.
3. Loosen belt from motor and idler pulleys.
4. Carefully remove the drum.

## DRYER EXHAUST CHANGE

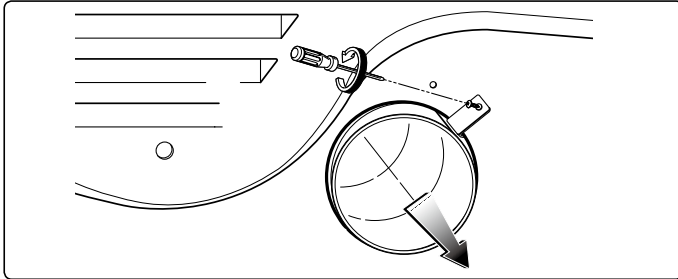

1. Remove the screw.

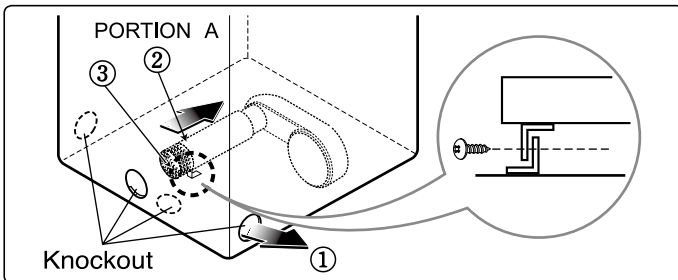

2-1. Detach and remove a knockout at the bottom, left or right side as desired. (Right side vent not available on gas dryer)  
①, ②, ③ the order of work.

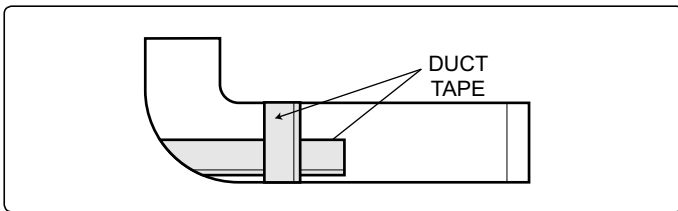

2-2. Replace it with an 11-inch (28 cm) duct connected to the blower housing, and attach the duct to the base. (The side vent kit is available as a service part, # 383EEL9001B.)

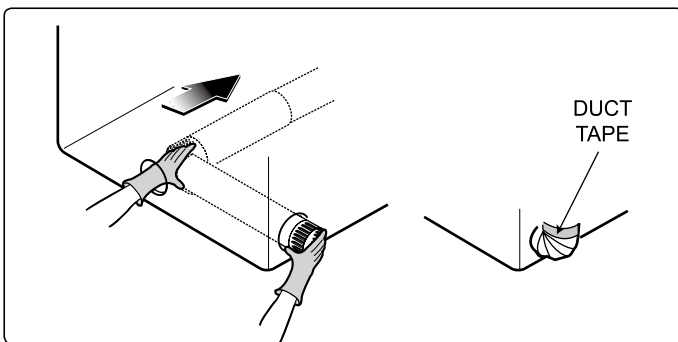

3-1. Pre-assemble a 4-inch elbow to a piece of duct.  
Wrap duct tape around the joint.

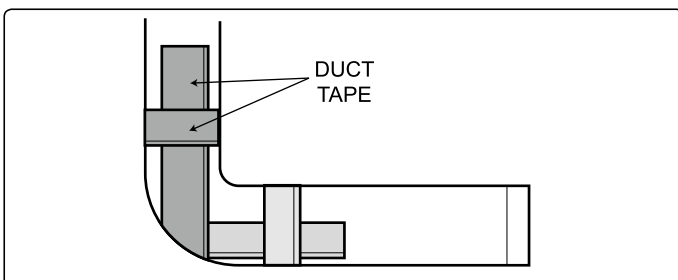

3-2. Insert the elbow duct assembly through the side opening and connect the elbow to the internal duct.

## FILTER ASSEMBLY

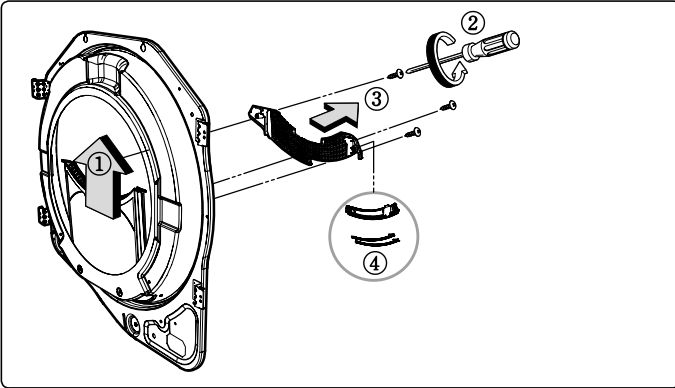

1. Remove the filter.
2. Remove 3 screws.
3. Remove the cover grid.
4. Disconnect the electrode sensor.

## BLOWER HOUSING

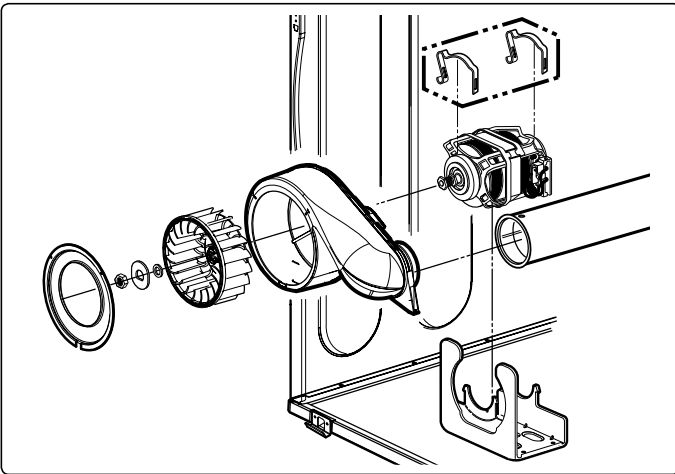

1. Disassemble the top plate.
2. Remove the cabinet cover and drum front.
3. Remove the Drum assembly.
4. Remove 2 screws and cover (air guide).
5. Remove the bolt and washer.
6. Remove the fan.
7. Disconnect the motor clamp and motor.

## BACK COVER

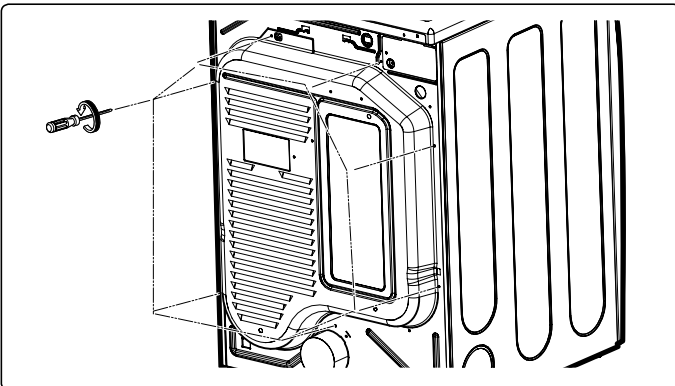

1. Disassemble the top plate.
2. Remove the cabinet cover and drum front.
3. Remove the drum assembly.
4. Remove 7 screws.
5. Remove the back cover.

## AIR DUCT

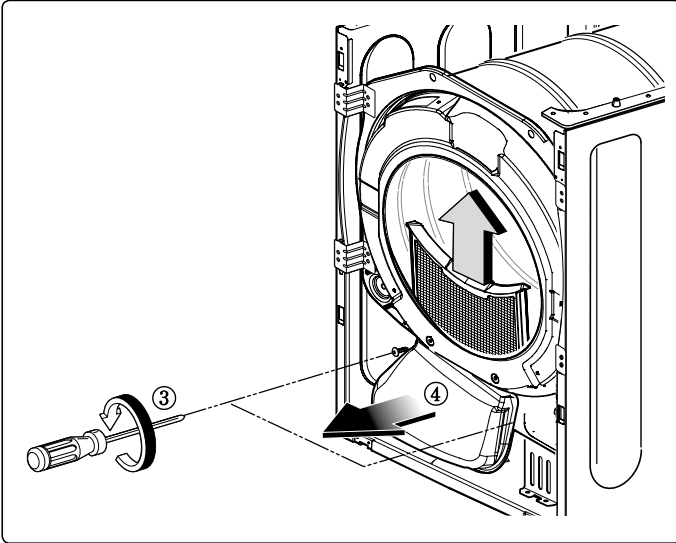

1. Disassemble the top plate.
2. Remove the cover cabinet.
3. Remove the filter and 2 screws.
4. Remove the air duct.

## Rollers

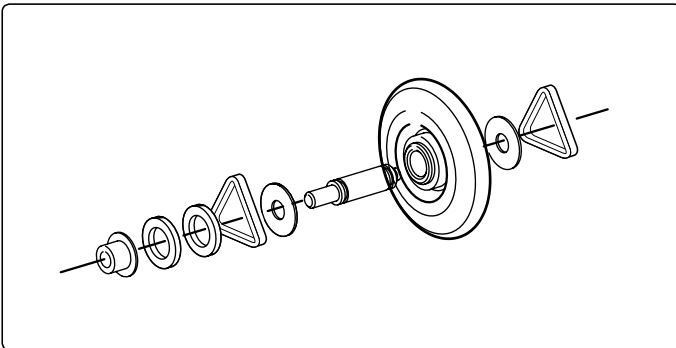

1. Disassemble the top plate.
2. Remove the cover cabinet and tub drum [front].
3. Remove the drum assembly and tub drum [rear].
4. Disconnect the air duct from the tub drum [front].
5. Remove the roller from the tub drum [front] and tub drum [rear].

20

EXPLODED VIEW

20-1-1. Control Panel & Plate Assembly - Coin / OPL Type

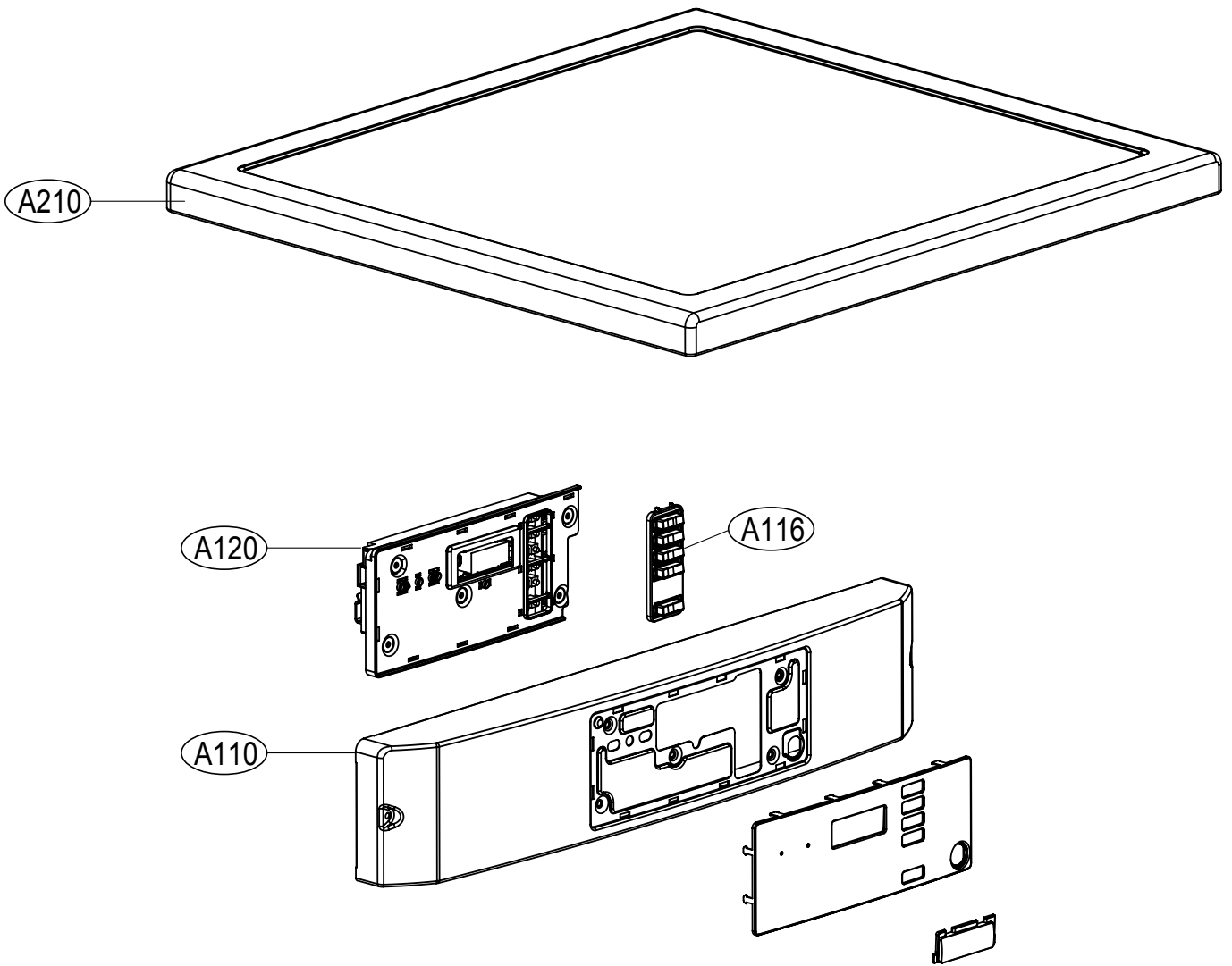

---

## 20-1-2. Control Panel & Plate Assembly - Card Type

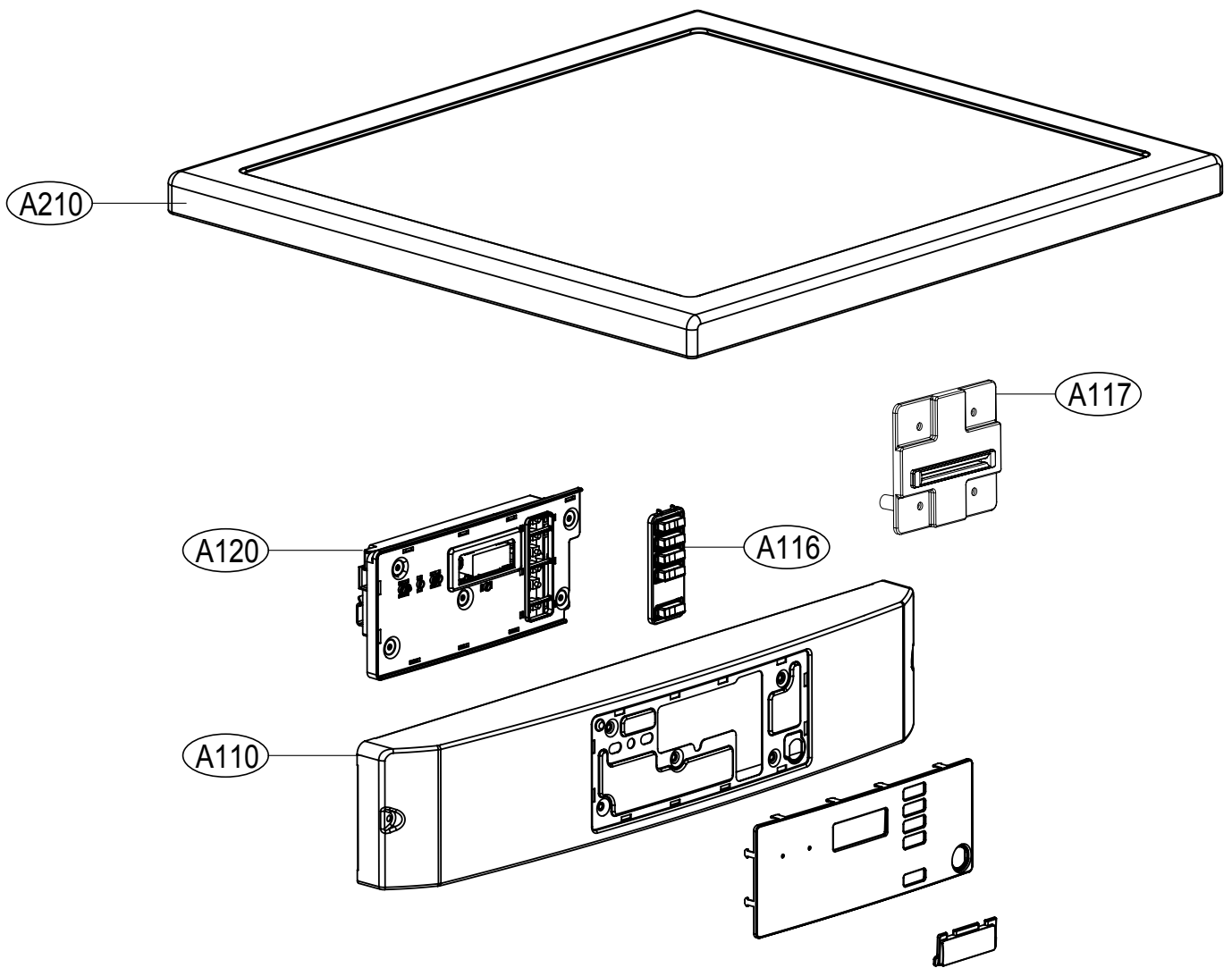

# 20-2-1. Cabinet & Door Assembly - Electric Stack Upper Type

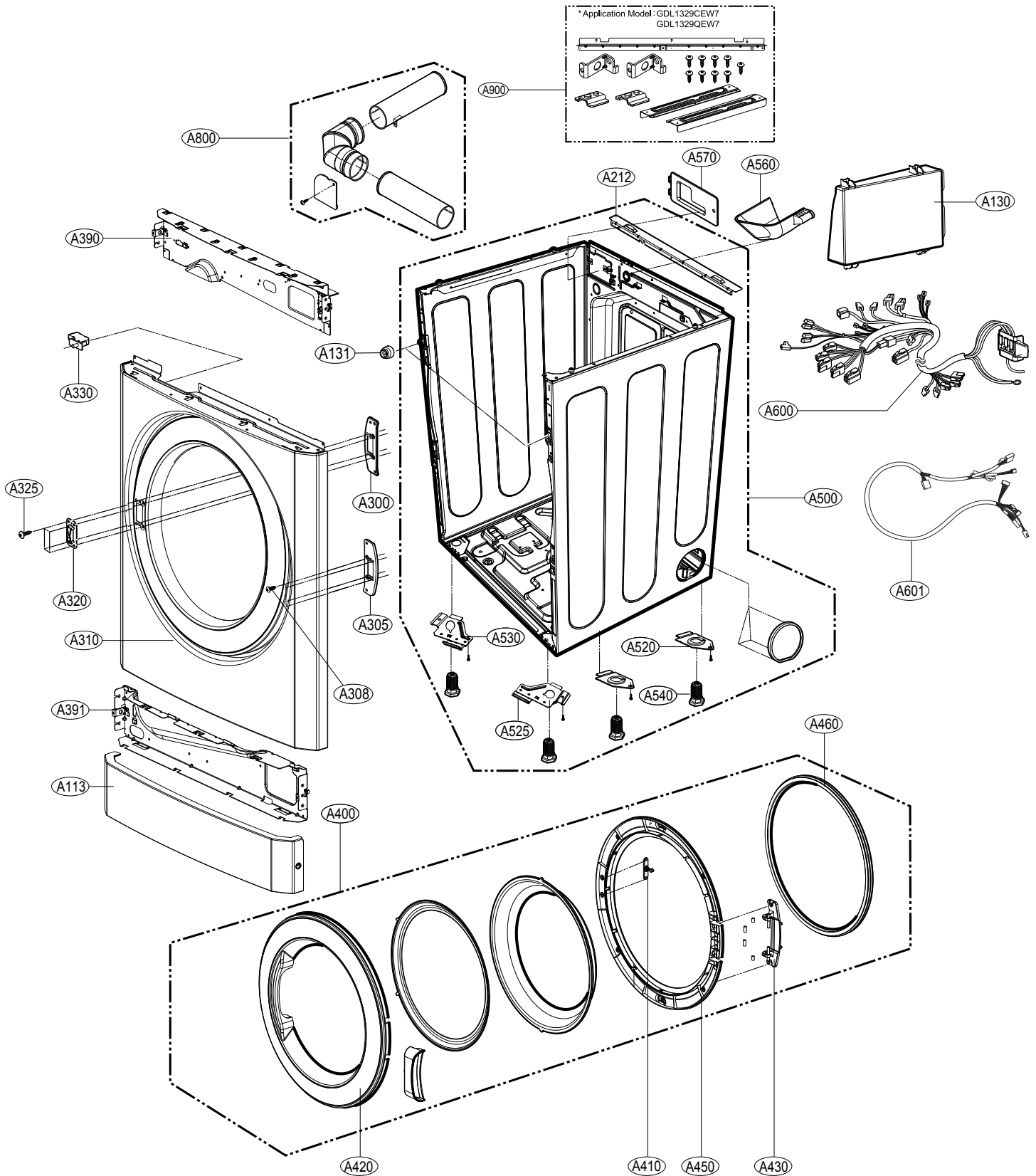

## 20-2-2. Cabinet & Door Assembly - Electric Stack Lower Type

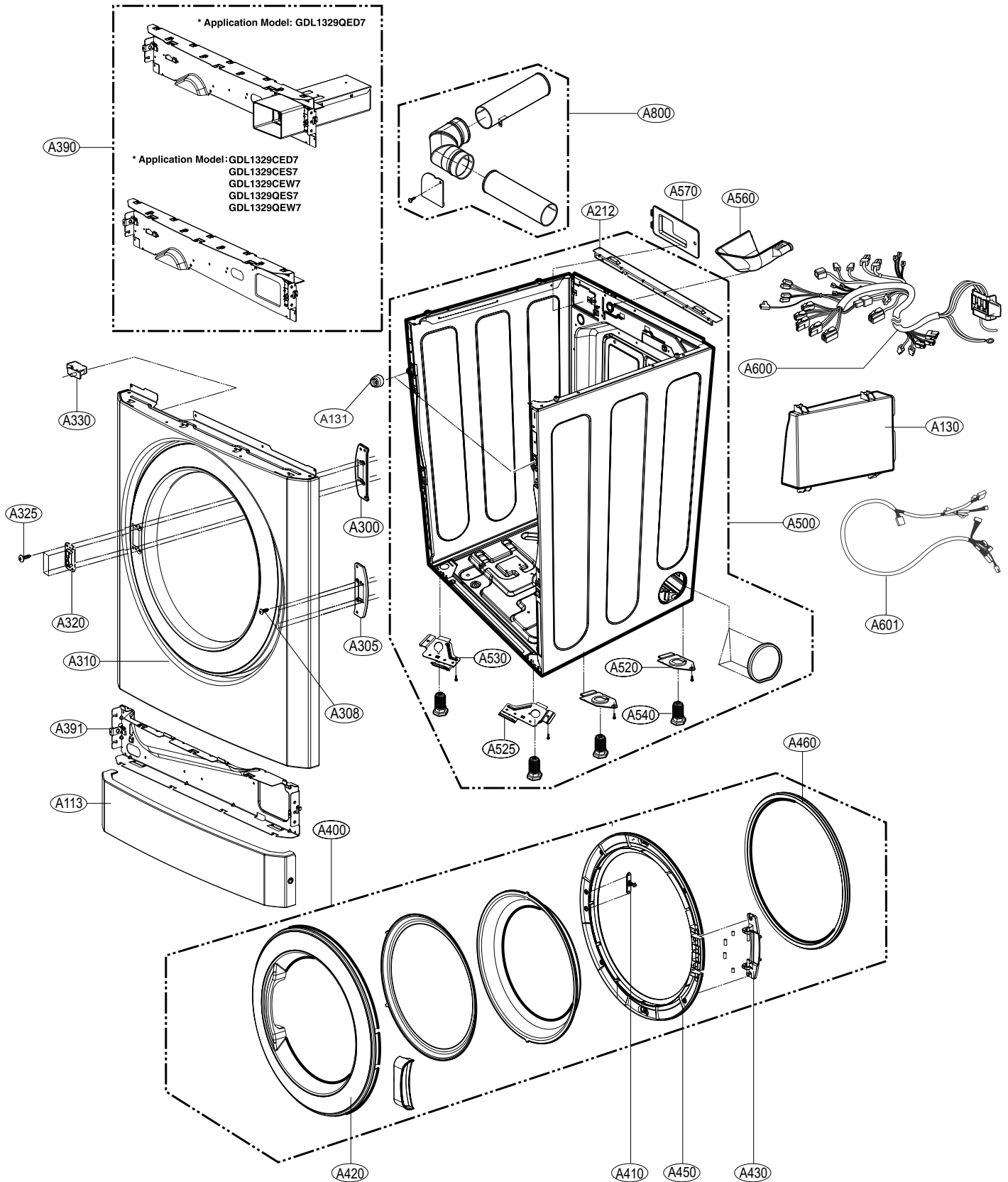

## 20-2-3. Cabinet & Door Assembly - Gas Stack Upper Type

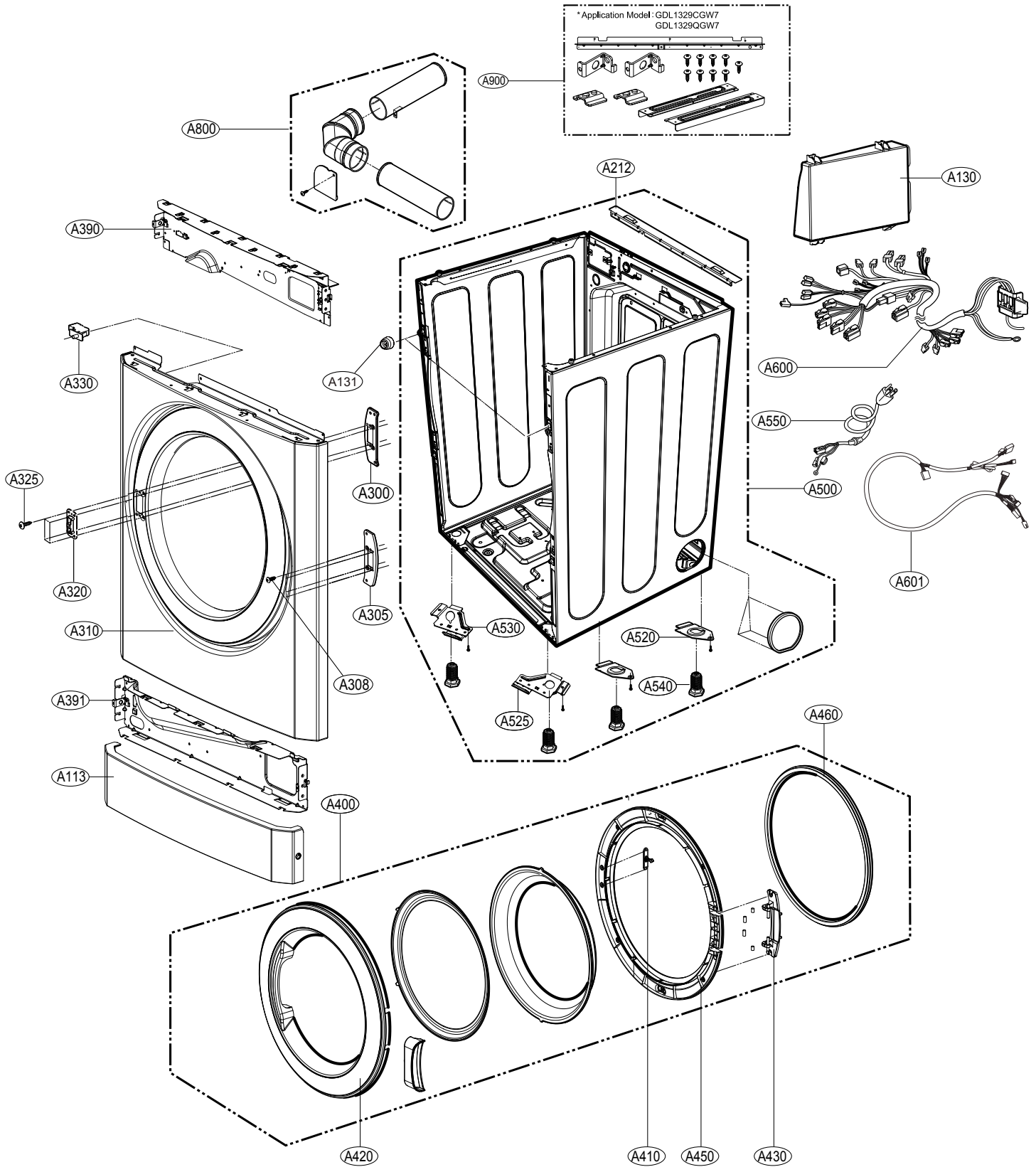

## 20-2-4. Cabinet & Door Assembly - Gas Stack Lower Type

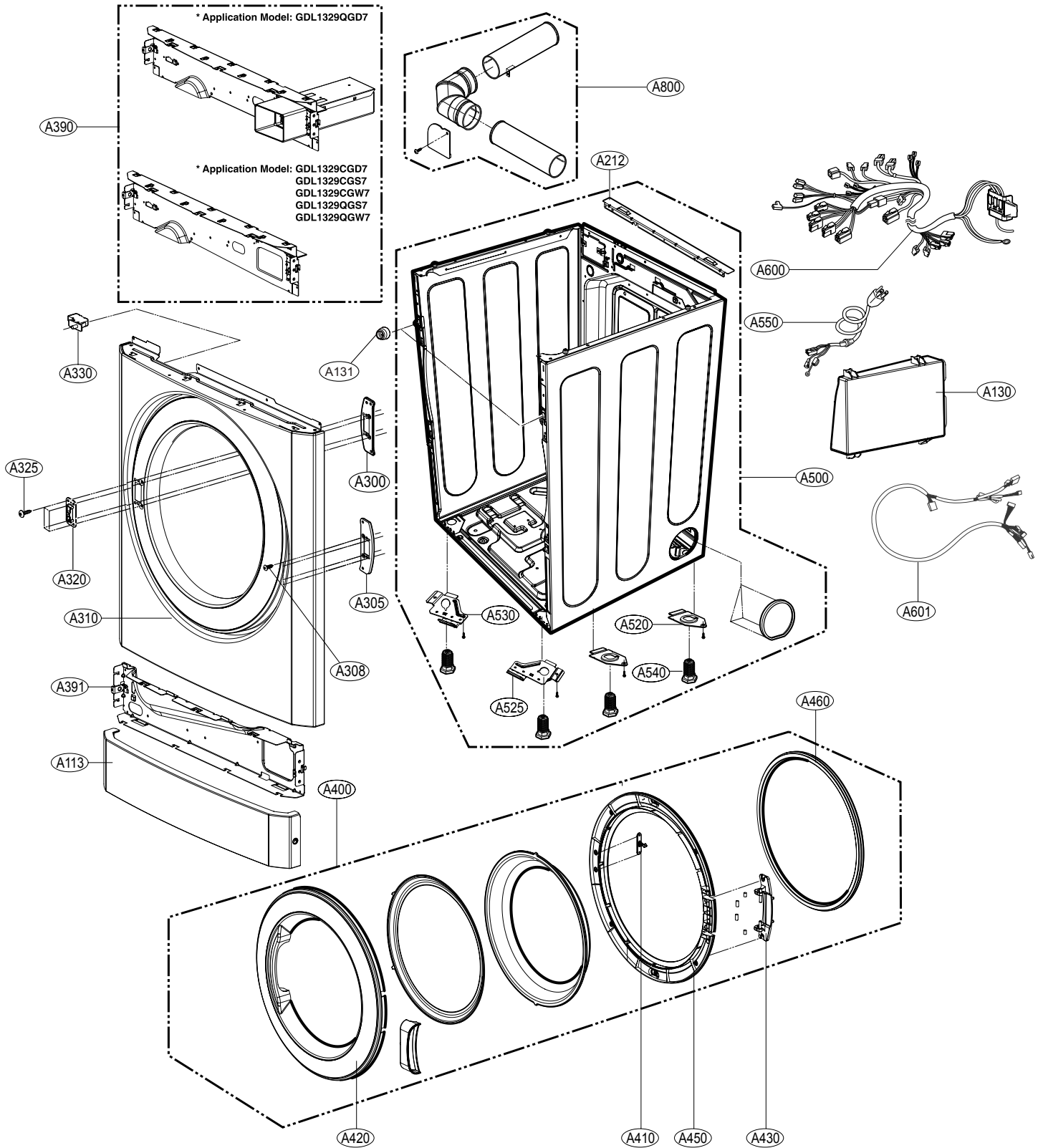



## 20-3-2. Drum & Motor Assembly: Gas Type

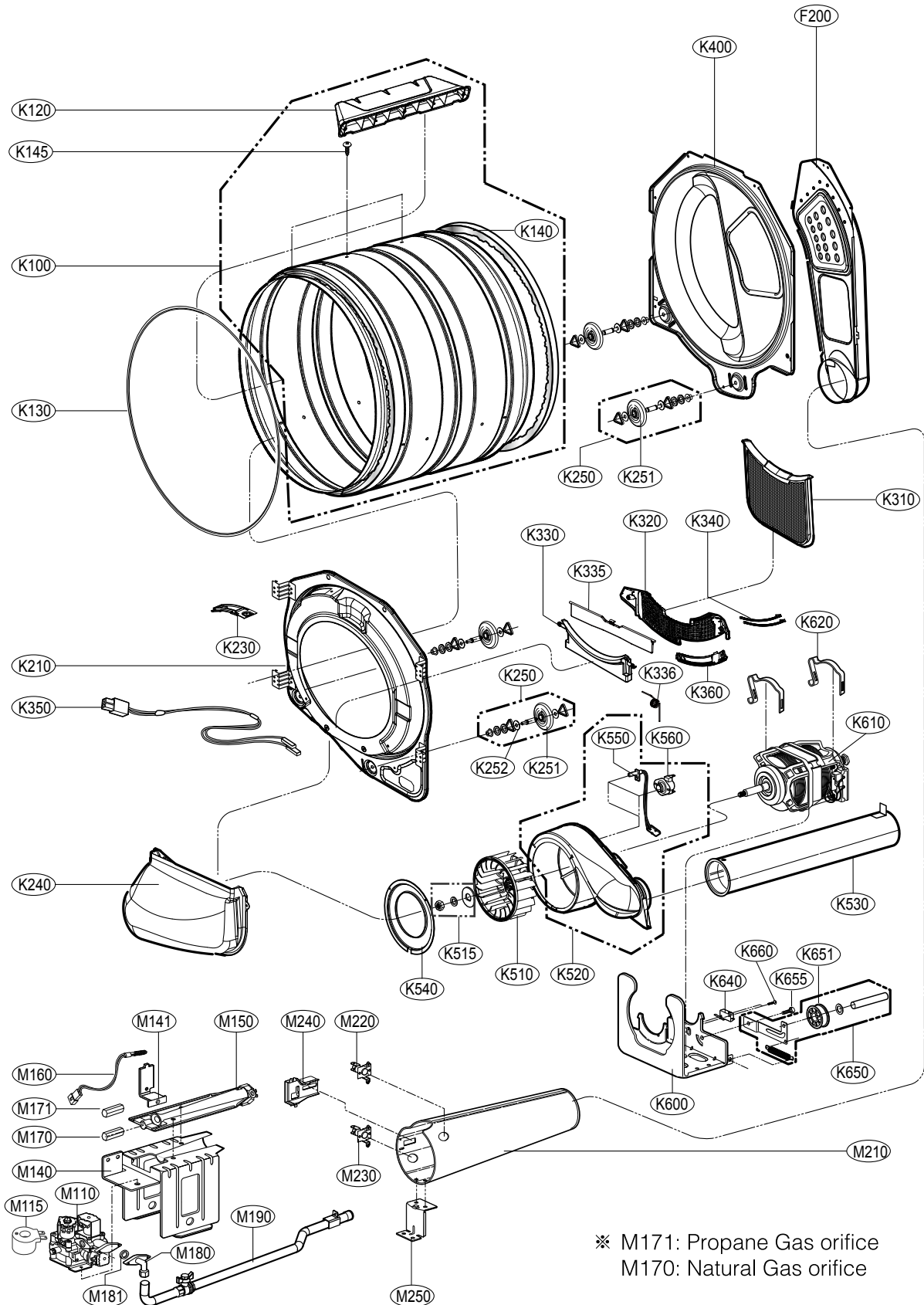

※ M171: Propane Gas orifice  
M170: Natural Gas orifice



P/No. : MFL71829011