

INSTALL/OWNER'S MANUAL

AIR CONDITIONER

Please read this installation manual completely before installing the product.
Installation work must be performed in accordance with the national wiring standards by authorized personnel only.
Please retain this installation manual for future reference after reading it thoroughly.

AC Smart IV
PACS4B000



P/NO : MFL69150602



[Representative] Ltd. LG Electronics RUS,
125047, Russia, Moscow, 4th Forest Lane, 4
[Manufacturer] LG Electronics Inc. Changwon 2nd
factory 84, Wanam-ro, Seongsan-gu,
Changwon-si, Gyeongsangnam-do, KOREA

www.lg.com

ENGLISH

РУССКИЙ ЯЗЫК

УКРАЇНСЬКА

ҚАЗАҚ ТІЛІ

БЕЛІН ПУСКАЛНОВА

ЎЗБЕК ТИЛИ

SAFETY PRECAUTIONS

- This product must be installed by an installation professional from an LG authorized service center.
- Any issues stemming from an installation by an unauthorized person is the responsibility of the user and will not be covered by warranty.
- The following safety precautions are to prevent any unforeseen dangers or damage.
- This product has been designed for business use, or for areas outside the home, and has passed the Electromagnetic Interference Test.

WARNING

It can result in serious injury or death when the directions are ignored.

CAUTION

It can result in minor injury or product damage when the directions are ignored.

WARNING

Installation

- To reinstall the product, please contact the dealer from where you purchased the product, or a service center for reinstallation service.
 - Installation of the product by an unauthorized person may result in fire, electric shock, explosion, injury, or a malfunctioning of the product.
- Do not twist or damage the power cord.
 - It may cause fire or electric shock.
- For electrical work, please contact the dealer from where you purchased the product, or a service center.
 - Disassembly or repair by an unauthorized person may result in fire or electric shock.
- Install the product in an area shielded from rain.
 - If water gets into the product, it may malfunction.
- Do not install the product in a humid area.
 - If the product is damp, it may malfunction.
- For installation of the product, please contact the dealer from where you purchased the product, or a service center.
 - Installation of the product by an unauthorized person may result in fire, electric shock, explosion, injury, or a malfunctioning of the product.
- For electrical work, please have an electrician do the work based on the installation manual and specified circuit diagram.
 - Using an unsuitable cord, or having a non-professional work on the electricals may result in fire or electrical shock.
- Do not place the product near a fire source.
 - It may result in the product catching fire.
- If the product is installed in a hospital or a communication base station, provide sufficient protective equipment against electrical noise.
 - The product may malfunction or other products may work abnormally.
- Securely install the product.
 - If the product is not secured during installation, it may fall or malfunction.
- Read the manual thoroughly to correctly install the product.
 - If not, an incorrect installation may cause fire or electric shock.

- When wiring the product, do not use a non-standard cable, nor extend the cable excessively.
 - It may cause a fire or electric shock.
- Securely install the power cord and communication cable.
 - An unsecure installation may result in a fire or electric shock.
- Do not connect the power cord to the communication terminal.
 - It may cause a fire, electric shock, or a product malfunction.
- Do not install the product in an area near combustible gas.
 - It may result in fire, electric shock, explosion, injury, or a malfunctioning of the product.

Use

- Do not place a heavy object on the power cord.
 - It may cause a fire or electric shock.
- Do not change or extend the power cord arbitrarily.
 - It may cause a fire or electric shock.
- Use the cord specific to the product.
 - Using an unauthorized non-standard cord may result in a fire or electric shock.
- Do not use a heat device near the power cord.
 - It may cause a fire or electric shock.
- Ensure that water never gets into the product.
 - It can result in an electric shock, or the product may malfunction.
- Do not place any container with liquid on the product.
 - The product may malfunction.
- Do not touch the product with wet hands.
 - It may cause a fire or electric shock.
- Use standard components.
 - Use of an unauthorized product may result in fire, electric shock, explosion, injury, or a malfunctioning of the product.
- If the product has been submerged in water, you should contact a service center.
 - It may cause a fire or electric shock.
- Do not shock the product.
 - The product may malfunction.
- Do not store or use any combustible gas or flammable substances near the product.
 - It may cause a fire, or a product malfunction.
- Do not disassemble, repair, or revamp the product arbitrarily.
 - It may cause a fire or electric shock.
- Children and the elderly should use the product under the supervision of a guardian.
 - Carelessness may cause an accident, or the product to malfunction.
- The guardian should prevent children from accessing the product.
 - The product may be damaged or it may fall, causing injury to children.
- Keep in mind the operating temperature range specified in the manual. If there is no operating temperature range in the manual, use the product between 0 and 40 °C (32 and 104 °F).
 - If the product is used outside this range, the product may be severely damaged.
- Do not press the switch or button with a sharp object.
 - It can result in an electric shock, or the product may malfunction.
- Do not wire the product while it is turned on.
 - It may cause a fire or electric shock.
- If the product sounds or smells different, stop using the product.
 - It may cause a fire or electric shock.

4 SAFETY PRECAUTIONS

- Do not place a heavy object on the product.
 - The product may malfunction.
- Do not spray water on the product, or clean it with a water-soaked cloth.
 - It may cause a fire or electric shock.
- Do not use the product for the preservation of animals and plants, precision instruments, art pieces, or for other special purposes.
 - It may cause property damage.
- Dispose the packing material safely.
 - The packing material may result in personal injuries.



CAUTION

Installation

- Securely install the product in an area where the weight of the product can be supported.
 - The product may fall and be destroyed.
- Do not use the product where there is oil, steam, or sulfuric gas.
 - It may effect the product's performance, or damage it.
- Check the rated power capacity.
 - It may cause a fire, or a product malfunction.
- Use the adapter provided with the product or power from a class 2 24 V~ transformer, depending on model.
 - If a non-standard adapter is used, the product may malfunction. The adaptor is not provided with the AC Smart package sold in the U.S.
- Be careful not to drop or damage the product when moving it.
 - The product may malfunction or the person may sustain an injury.
- Ensure that the cord is connected securely to prevent dew, water, or insects from getting into the product.
 - If a foreign substance gets inside, it may cause an electric shock or the product may malfunction.

Use

- Clean the product with a soft cloth, but not with a solvent-based detergent.
 - The use of a solvent-based detergent may cause a fire or deform the product.
- Do not touch the panel using a pointy or sharp object.
 - It can result in an electric shock, or the product may malfunction.
- Do not let the product come into contact with a metal substance.
 - The product may malfunction.
- When sterilizing or disinfecting, stop using the product.
 - The product may work abnormally.
- Do not touch inside the product.
 - The product may malfunction.
- Check the condition of the product after using the product for an extended period of time.
 - If the product is used for an extended period of time, the product's condition may be worsen, causing injury to the user.
- Do not leave the product near a flower base, water bottle, or any other liquids.
 - It may cause a fire or electric shock.
- If the liquid crystal of the product is broken, please do not let your skin such as face or hands contact with.
 - Personal injury or property damage may occur.

- Transformer selection:
 - Select an insulating product that complies with IEC61558-2-6 and NEC Class 2.
 - In addition, consider the combined power consumption of the modules, accessories, and field devices installed for the selection of an appropriate transformer.
Main module current: 24 V~, 850 mA
 - Use the provided adaptor when using DC 12 V. The adaptor is not provided with the AC Smart package sold in the U.S.

Class A device

NOTE

This equipment has been tested and found to comply with the limits for a Class A digital device, pursuant to part 15 of the FCC Rules.

These limits are designed to provide reasonable protection against harmful interference when the equipment is operated in a commercial environment.

This equipment generates, uses, and can radiate radio frequency energy and, if not installed and used in accordance with the instruction manual, may cause harmful interference to radio communications. Operation of this equipment in a residential area is likely to cause harmful interference in which case the user will be required to correct the interference at his own expense.

CAUTION

Changes or modifications not expressly approved by the manufacturer responsible for compliance could void the user's authority to operate the equipment.

PREPARATION

AC Smart IV Overview

AC Smart IV is a central controller installed in the management office of a building, or in the administration office of a school, to monitor and operate, via touch screen or Web access, the indoor units, ERV (ERV: Energy Recovery Ventilator, ERV DX: Direct Expansion Energy Recovery Ventilator), DI/DOs, DOKITs, AWHPs, AHUs and I/O Modules installed inside the building. AC Smart IV can manage, collectively or individually, the indoor units, ERV, DI/DOs, DOKITs, AWHPs and AHUs for up to 128 devices. (Or the indoor units, ERV, DI/DOs, DOKITs, AWHPs and AHUs for up to 64 devices and 9 I/O Modules)

Components

The following components are included in the package box. Open the box and verify that all components are included.



AC Smart IV



AC Smart IV
User's Manual

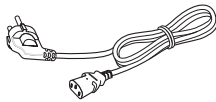

Power Cord



Power Adapter



INSTALL/OWNER'S
MANUAL

Power Cord, Power Adaptor and Quick Guide are not provided with the AC Smart IV package sold in the U.S.

! NOTE

The figures of the components and optionally purchased products shown may differ from the actual components and products.

Features and Functions

The features and functions of AC Smart IV Premium are as follows.

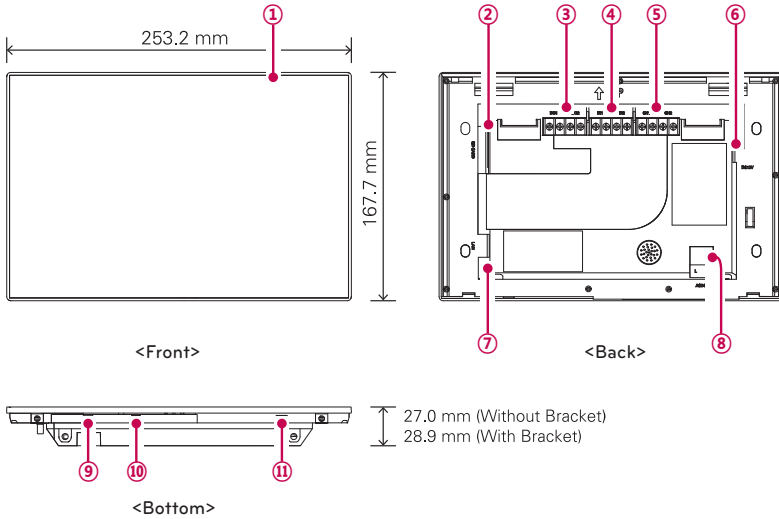

Number	Item	Description
①	Touch Screen	<ul style="list-style-type: none"> • 10.2 inch LCD control panel • AC Smart IV Premium control and information display
②	SD Memory Slot (for service)	SD card memory slot for software upgrade
③	DO Port	2CH DO port
④	DI Port	2CH DI port
⑤	485 Port	2CH 485 port (CH1: AHU, CH2: devices other than AHU)
⑥	DC 12 V Input Port	DC 12 V power input port
⑦	LAN Port	LAN cable port for Ethernet connection (100Mbps/10Mbps)
⑧	24 V~ Input Port	24 V~ power input port
⑨	Micro USB Port	USB 2.0 to connect USB memory sticks storing floor plans, reports, statistics, etc.
⑩	Mini USB Port (for service)	PC port for software upgrade
⑪	Power ON/OFF	<ul style="list-style-type: none"> • Push less than 10 seconds to control AC Smart IV LCD backlight. • Push 10 seconds or more to reset AC Smart IV. • If you are not going to use AC Smart IV for a long time, it is recommended that the product be turned off to prolong the LCD backlight's life.

Installation

To use AC Smart IV, build an environment for which AC Smart IV can communicate with devices like the indoor unit, ERV, DI/DO, DOKIT, AWHP, AHU and I/O Module. Use AC Smart IV to register those devices.

AC Smart IV should be installed in the following order:

STEP 1. Check the installation environment and configure the device address.

Check the network configuration against the interfaced devices before installing AC Smart IV and allocate a unique central control address for each connected device.

STEP 2. Connect V-Net devices with AC Smart IV.

Use an RS485 cable to connect V-Net devices with AC Smart IV.

STEP 3. Login and register the devices.

Login to AC Smart IV and register those devices that have their address set.



CAUTION

The installation of AC Smart IV must be done by a professional. Be sure to contact a qualified engineer for the installation. If you have a question or request regarding the installation, contact an installation professional at an authorized LG service center or LG Electronics.



NOTE

Maximum node numbers which can be connected to RS485 communication line.

- **Multi V**
Maximum of 16 nodes can be connected to 1 RS485 line.
- **Multi/Single**
Maximum of 32 nodes can be connected to 1 RS485 line.
- **ERV**
Maximum of 32 nodes can be connected to 1 RS485 line.

Check the installation environment and configure the device address

AC Smart IV can connect up to 128 devices (including indoor units, ERV, DI/DOs, DOKITs, AWHPs, AHUs) or 64 devices (including indoor units, ERV, DI/DOs, DOKITs, AWHPs and AHUs) and 9 I/O Modules.

The following shows an example of connecting AC Smart IV with such devices.

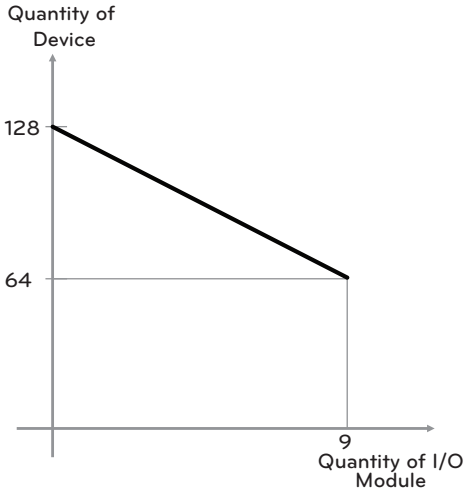

Quantity of I/O Module	Quantity of Device
0	128
1	121
2	114
3	107
4	100
5	93
6	86
7	79
8	72
9	64

* Devices : Indoor units, ERV, DI/DOs, DOKITs, AWHPs, AHUs

AC Smart IV connects with PI485 and uses RS485 to communicate and exchange information. Allocate unique addresses to those devices (internal units, ERV, DI/DOs, DOKITs, AWHPs, AHUs, I/O Modules) that will connect with AC Smart IV. The addresses are hexadecimal numbers that can be chosen from 00 to FF.

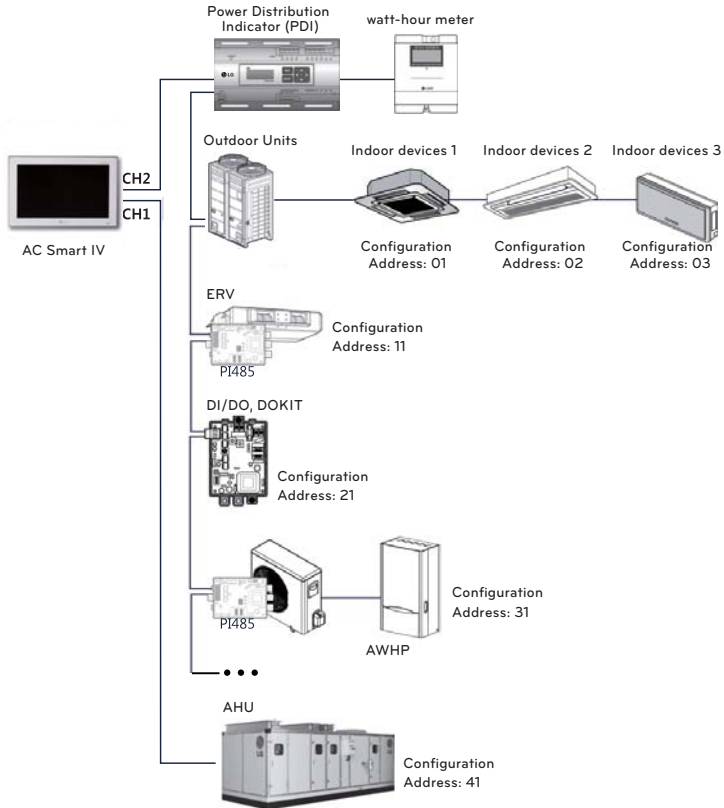

NOTE

- The maximum allowed communication distance guaranteed by LG Electronics is 1 000 m. It means that the distance between AC Smart IV and the farthest device should not exceed 1 000 m. It is recommended that the communication cable use 0.75 mm square or more.
- For indoor units, ERV, DI/DOs, DOKITs, AWHPs, AHUs and I/O Modules, you cannot allocate identical addresses among devices of the same type. Allocate different addresses for devices of the same type. (the indoor unit and DOKIT cannot use the same address.)
- Each device which can be used with PDI must be set to a unique address when connected with PDI. For further information about the devices can be used with PDI, please refer to the PDI manual.
- Connecting I/O Module, address setting should not be 00 because 00 is used to Broadcast in MODBUS communication.

Connect AC Smart IV

You can install AC Smart IV and its cables as follows.

- 1 Choose a space for AC Smart IV.
 - Prior to securing AC Smart IV, check if the space is suitable for installing AC Smart IV, an RS485 cable, power cord, and an Ethernet cable.
- 2 Secure the back panel of AC Smart IV to the wall under which the RS485 cable is located.

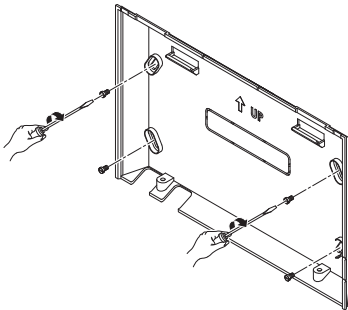

- 3 Extend the RS485 cable through the top opening of the back panel.

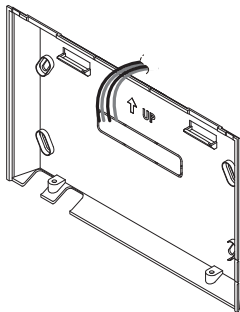

- 4 Connect the RS485 cable, which is located behind the AC Smart IV, to the RS485 terminal.

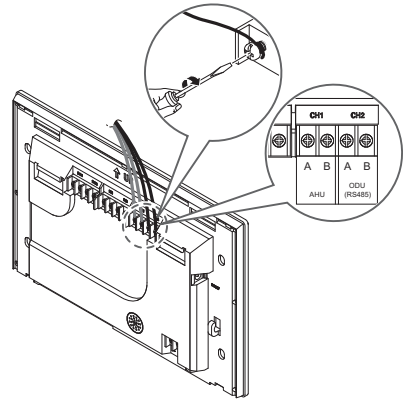

CAUTION

The RS485 cable has polarity, so be careful about keeping polarity when connecting the cables.

- 5 To use the network functions (email transmission and web control) provided by AC Smart IV, connect an Ethernet cable to the LAN port on the back of AC Smart IV.

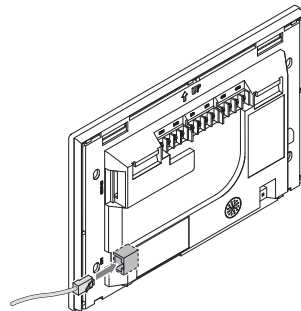

12 PREPARATION

6 Connect the power.

• For global models

- On the back of AC Smart IV, connect the power adapter to the power port.

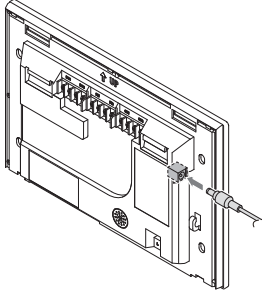

The adaptor is not provided with the AC Smart IV package sold in the U.S.

! NOTE

You can hang the power cord on the power cord hanger located below the power port.

• For US models

- At the bottom of AC Smart IV, connect the power cord to the power port.

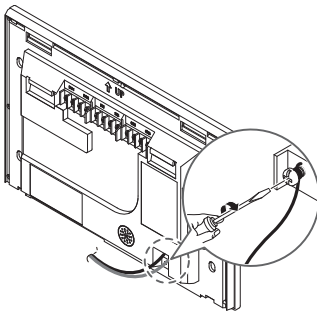

! NOTE

In some countries, except for the U.S, you can connect the DC 12 V power to the AC Smart IV by using the provided adapter. If necessary, connect the 24 V~ power to the AC Smart IV.

- After attaching the hook on the top of the main body to the top of the rear panel installed on the wall, please push the top of the main body unit forward for firm attachment.

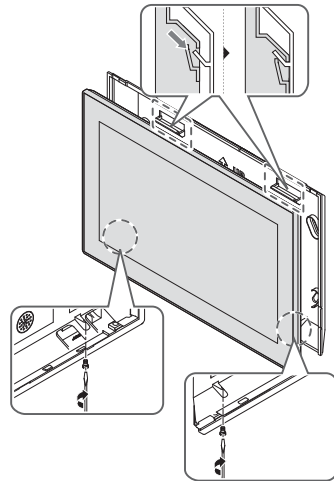

! CAUTION

Please screws 2 points from the bottom of the unit to prevent from falling.

! NOTE

Product removal

After removing 2 screws from the bottom of the body, slightly pull the body using the flatblade screwdriver and lift up the body to remove the product.

STARTING

Login and logout

The following explains how to log in and out of AC Smart IV.

AC Smart IV is, can be controlled not only equipment, but also Web. If you enter the IP address of the AC Smart IV in the address bar of the Internet without the installation of another program, the central control program AC Smart IV, Web server has is executed automatically, to use the functionality of the various content I can.

The manual will explain AC Smart IV standard equipment.

NOTE

- You will need the Adobe Flash Player be installed for the Web control.
(Recommended specification : Adobe Flash Player 11)
- The special character (^), (!) and (,) are not available.

Login

You can login as follows.

- 1 Run Central Controller.
- 2 After entering your ID and password in the login window, click(touch) [Confirm].
- You are now logged in.

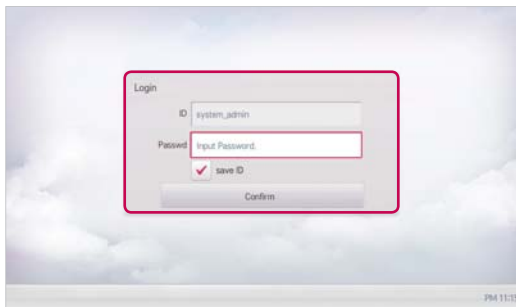

Logout

You can logout as follows.

- 1 On the top right of the Central Controller home screen, click(touch) the [Logout] button.
- You are now logged out.

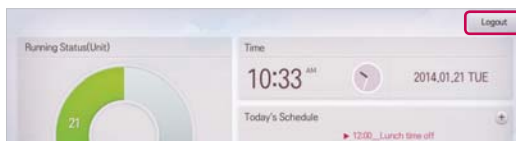

HINT

Pre-Tech Support Checklist

If the product malfunctions, please check the following before calling the service center.

Symptom	Check	Actions
The alarm sound does not stop.	<ul style="list-style-type: none"> • Is the demand controller working normally? • Is the LAN cable connected to the product? 	<ul style="list-style-type: none"> • Check if the demand controller is normal. • Check if the LAN cable is connected correctly to the device.
All products continue to turn off.	Is DI1 CH short-circuited?	Check if DI1 CH is open or short circuited. (DI1 CH should be always open except when an emergency occurs.)
The product was reset at midnight.	The product is automatically reset every morning at 02:05 am.	
The device is not controlled.	Is the device you want to control not locked?	Check if the lock is on and if so, disable the lock.
The device icon has an error mark.	Is the device with errors connected correctly?	If devices are not correctly connected, the error sign is displayed. Check the connection status of the devices.

