

**Languages in this manual:**

English

Bosanski

Catalán

Dansk

Deutsch

ελληνικά

Espanol

Eesti

Français

Gaelach

Hrvat

SAFETY INFORMATION  
O&M INFORMATION  
INSTALLATION MANUAL  
TDS - TECHNICAL DATA SHEET



# CONTENTS

<b>1. Safety instructions</b> .....	3
1.1 General information .....	3
1.2 Safety instructions for users.....	4
1.3 Safety instructions for installers .....	4
<b>2. Product description</b> .....	5
2.1 Product identification.....	5
2.2 Intended use.....	5
2.3 CE marking .....	5
2.4 Technical data.....	5
2.5 ErP data.....	5
<b>3. Installation instructions</b> .....	6
3.1 Products covered by these instructions.....	6
3.2 Included in delivery.....	6
3.3 Product dimensions.....	6
3.4 Requirements for installation location .....	7
3.5 Pipe installation.....	9
<b>4. Initial commissioning</b> .....	10
4.1 Filling with water.....	10
4.2 Control points.....	10
4.3 Draining.....	10
4.4 Handover to end-user .....	10
<b>5. Warranty conditions</b> .....	11
5.1 Customer service.....	11
<b>6. Removing the product</b> .....	11
6.1 Removal.....	11
6.2 Returns scheme.....	11



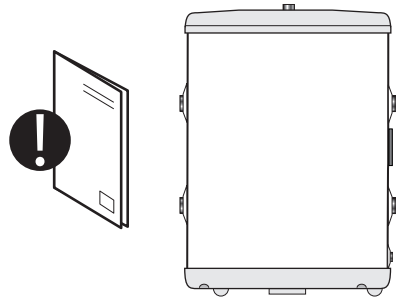

# 1. SAFETY INSTRUCTIONS

## 1.1 General information











- Read the following safety instructions carefully before installing, maintaining or adjusting the buffer tank.
- Personal injury or material damage may result if the product is not installed or used in the intended manner.
- Keep this manual and other relevant documents where they are accessible for future reference.
- The manufacturer presupposes compliancy (by the end-user) with the safety, operating and maintenance instructions supplied and with the installation manual and relevant standards and regulations in effect at the date of installation.



Symbols used in this manual:

 WARNING	Could cause serious injury or death
 CAUTION	Could cause minor or moderate injury or damage to property
	DO NOT
	MUST BE DONE

## 1.2 Safety instructions for users

 WARNING	
	This appliance is not intended for use by persons (including children) with reduced physical, sensory or mental capabilities or lack of experience and knowledge, unless they have been given supervision or instruction concerning use of the appliance by a person responsible for their safety. Children should be supervised to ensure that they do not play with the appliance.
	This appliance can be used by children aged from 8 years and above and persons with reduced physical, sensory or mental capabilities or lack of experience and knowledge if they have been given supervision or instruction concerning use of the appliance in a safe way and understand the hazards involved. Children shall not play with the appliance.
	Cleaning and user maintenance shall not be made by children without supervision.
	Installation must be carried out in accordance with the valid regulations and according to the instructions of the manufacturer and by qualified staff.
	In a closed, pressurised system of installation, it is obligatory to install a safety valve (not included) on the system with a rated pressure of max. 0.3 MPa (3 bar) (see the label), which prevents the elevation of pressure in the buffer by more than 0.1 MPa (1 bar) above the rated pressure.
	The outlet of the safety valve must be installed facing downwards and in a non-freezing area.
	To ensure proper functioning of the safety valve, the user must perform regular controls (min. annually) to remove any limescale and make sure the safety valve is not blocked.
	Do not install a stop valve between the buffer and the safety valve.
	If the system has to be switched off, please drain any water from the buffer to prevent freezing.
	Please do not try to fix any defects of the buffer on your own. Call the nearest authorized service provider.

## 2. PRODUCT DESCRIPTION

### 2.1 Product identification

Identification details for your product can be found on the type plate fixed to the product. The type plate contains details of the product in accordance with EN 12897:2016 as well as other useful data. See Declaration of Conformity at the manufacturers' for more information.

The product is designed and manufactured in accordance with:

Pressure vessel standard - EN 12897:2016

The manufacturer is certified according to the following standards:

Quality - ISO 9001

Environment - ISO 14001

Work environment - ISO 45001

### 2.2 Intended use

The product is designed for use as a buffer tank for both heating and cooling systems, and is designed for fitting in a closed circuit system.

### 2.3 CE marking

The CE mark shows that the product complies with the relevant Directives. See Declaration of Conformity at the manufacturers' website for more information.

The Product complies with the following directive(s):  
Pressure Equipment Directive PED 2014/68/EU

The safety valve(s) used must be CE marked and conform to PED 2014/68/EU.

### 2.4 Technical data

LG Model no.	Product code:	Capacity, persons	Weight (Net), kg.	Dia. x Height mm.	Freight vol. m <sup>3</sup>	Volume 40°C water	Thermostat setting °C
11015372	SB006SAANO EPWXLEU	-	15	ø434x741	0,15	-	-
11015373	SB010SAANO EPWXLEU	-	22	ø434x1168	0,25	-	-

The products are classified as IP21.

### 2.5 ErP data - Technical Data Sheet

Brand	LG Model no.	Model name	Actual volume L	Heat loss W	ErP Rating
LG Electronics	11015372	SB006SAANO EPWXLEU	57	44	C
LG Electronics	11015373	SB010SAANO EPWXLEU	100	49	B
Regulation: 2017/1369/EU - Regulation: EU 812/2013			Directive: 2009/125/EC - Regulation: EU 814/2013		
Heat loss tested acc. to standard EN 12897:2016					

### 3. INSTALLATION INSTRUCTIONS

#### 3.1 Products covered by these instructions

SB006SAANO EPWXLEU

SB010SAANO EPWXLEU

#### 3.2 Included in delivery

Ref no.	Pcs.	Description
1	1	Buffer tank with sensor bracket
2	1	Manual (this document)
3	1	Stainless steel wall bracket - included

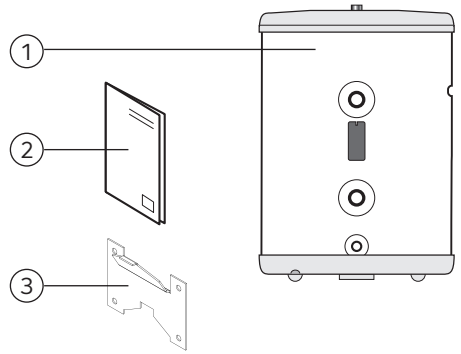

#### 3.3 Product dimensions

All dimensions in mm.

Product	A	B	C	D	∅
SB006SAANO	741	528	198	102	430
SB010SAANO	1175	962	192	96	430

Tolerance +/- 5 mm

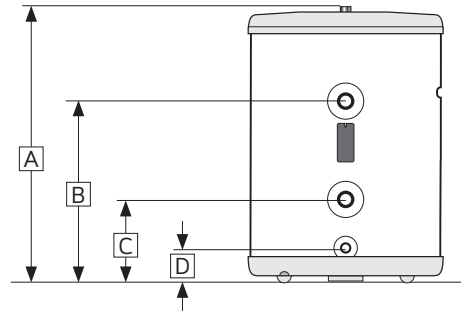

#### 3.3.1 Delivery

The product should be transported carefully as shown, with packaging. Use the handles in the box (X).

#### ⚠ CAUTION

Pipe stubs, valves etc. must not be used to lift the product as this could cause malfunctions.

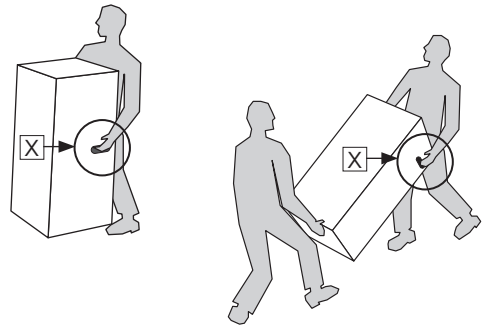

### 3.4 Requirements for installation location and positioning

⚠ CAUTION

❗	The product must be placed in a room with a drain to prevent any damages in case of water escaping from the product..
❗	The product must be placed in a dry and permanently frost-free position.
❗	The product must be placed on a floor or wall suitable for the total weight of the product when in operation. See table in page 5. Wall bracket is supplied.
❗	The product must have a clearance for servicing of 40 cm in front of the unit / 10 cm over the top connection.
❗	The product must be easily accessible for servicing and maintenance.

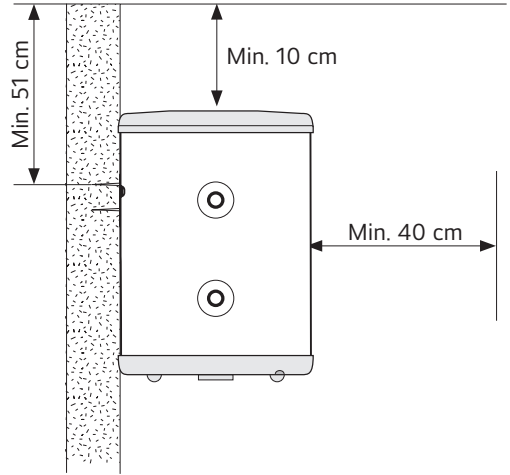

### 3.4.1 Temperature sensor installation

The product is equipped with a temperature sensor bracket which allows installation of a 6 or 8 mm. temperature sensor. To install the temperature sensor follow the instructions below.

1. Remove temperature sensor bracket (A) from tank body by gripping it and pulling straight out.
2. Insert temperature sensor (B) firmly into the appropriate grooves in the sensor bracket and place the temperature sensor cable in the cable slot (D). An 8 mm. sensor (shown) fits in the upper grooves (C) while a 6 mm. sensor fits in the lower groove (E).
3. Refit the sensor bracket into the tank body, ensuring the bracket is inserted fully to establish proper contact between the sensor and the stainless steel inner tank surface. Make sure the sensor cable is positioned properly in the cable slot (D) to avoid potential damage to the cable.

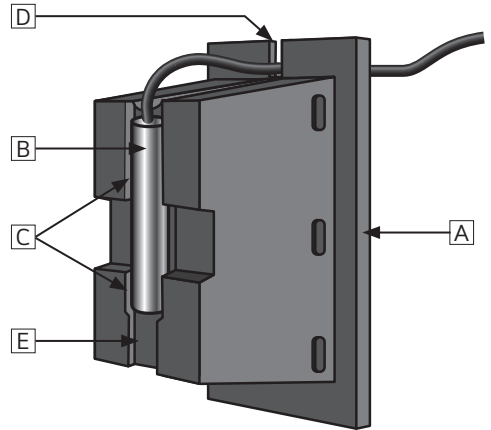
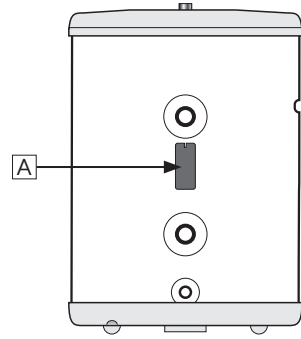

### 3.5 Pipe installation

The product is designed to be permanently connected to the heating system, max. pressure 3 bar / 0,3 MPa. Approved pipes of the correct size should be used for installation. The relevant standards and regulations must be followed.

#### 3.5.1 Pipe and plug fitting

- A) Run pipes of suitable size to the connections shown (2 and 3), and affix with suitable sealant.  
 B) Unused connections must be plugged securely. Use 1" brass plugs (not supplied).  
 C) The venting connection (1) must be plugged when the product is filled with water, see pt. 4.1.

#### 3.5.2 Torque settings

Component	Torque
Air vent - 1/2" (A60-100)	5 Nm (+/- 1 - hand force)
Drain - 1/4" (A60-100)	5 Nm (+/- 1 - hand force)
Air vent - 3/4" (A200)	30 Nm (+/- 3)
Drain - 3/4" (A200)	30 Nm (+/- 3)
Brass plug - 1"	40 Nm (+/- 5)

No.	Dimension	Connection description
1	G 1/2" F	Venting (plugged)
2	G 1" F	Flow/ret. connection upper
3	G 1" F	Flow/ret. connection lower
4	G 1/4" F	Drain (plugged)

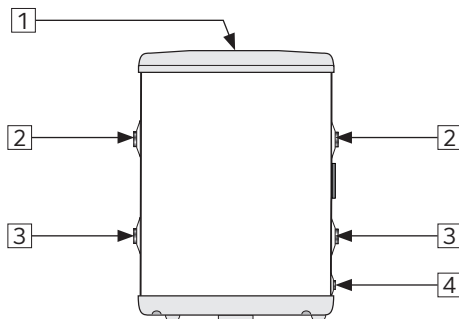

#### 3.5.3 Fitting instructions

⚠ CAUTION	
❗	The product must be placed in a room with a drain to prevent any damages in case of water escaping from the product. The product must be placed in a permanently frost-free environment.
❗	The product must be properly aligned vertically and horizontally, on a floor or wall suitable for the total weight of the product when in operation. See type plate.
❗	The product must have a clearance for servicing of 40 cm in front of the unit / 10 cm over the top connection.

## 4. INITIAL COMMISSIONING

### 4.1 Filling with water

First check that all pipes are connected correctly.  
Then do the following:

- A) Vent the system, preferably at its highest point.
- B) Open water supply to the product. When water flows out of the vent the system is full.

### 4.2 Control points

- A) Check that all pipe connections to/from the product are tight and not leaking.
- B) Check that the product is standing/hanging level vertically and horizontally.

### 4.3 Draining

#### WARNING

**The water temperature in the product is high and could cause scalding. Special care should therefore be taken when emptying the product.**

- A) Disconnect the power supply.
- B) Shut off incoming water supply.
- C) Open the air vent connection (1). Leave open while emptying (prevents vacuum).
- D) The product is emptied via the drain (2).
- E) Close air vent connection (1)..

### 4.4 Handover to end-user

THE INSTALLER MUST:

- Brief the end-user on safety and maintenance instructions.
- Brief the end-user on settings and emptying the product.
- Hand this installation manual over to the end-user.
- Enter contact details on the type plate on the product.

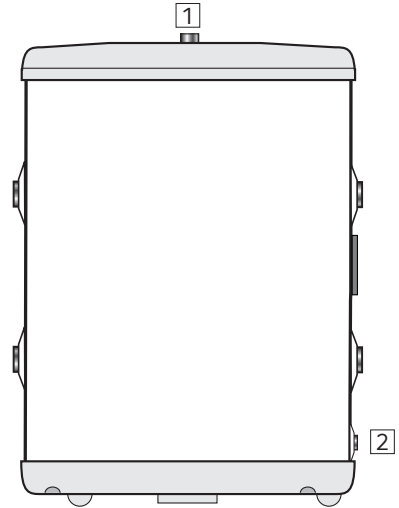

## 5. WARRANTY CONDITIONS

### 1. Scope

LG Electronics (hereinafter called LG) warrants that the Product will: i) conform to LG specification, ii) be free from defects in materials and workmanship, subject to conditions below.

All components carry a warranty. See local warranty conditions for further information. The conditions and limitations set out below must apply.

### 2. Coverage

If a defect arises and a valid claim is received within the statutory warranty period, at its option and to the extent permitted by law, LG must either; i) repair the defect, or; ii) replace the product with a product that is identical or similar in function, or; iii) refund the purchase price.

If a defect arises and a valid claim is received after the statutory warranty period has expired, but within the extended warranty period, LG will supply a product that is identical or similar in function. LG will in such cases not cover any other associated costs. Any exchanged Product or component will become the legal property of LG.

Any valid claim or service does not extend the original warranty. The replacement Product or part does not carry a new warranty.

### 3. Conditions

The Product is manufactured to suit most public water supplies. However, there are certain water chemistries (outlined below) that can have a detrimental effect on the Product and its life expectancy. If there are uncertainties regarding water quality, the local water supply authority can supply the necessary data.

The warranty applies only if the conditions set out below are met in full:

The Product has been installed by a professional installer, in accordance with the instructions in the installation manual and all relevant Codes of Practice and Regulations in force at the time of installation.

The Product has not been modified in any way, tampered with or subjected to misuse and no factory fitted parts have been removed for unauthorized repair or replacement. The product has been connected to the public power grid and it has not been connected to an external power supply control unit not approved by LG. The Product has only been connected to a domestic mains water supply in compliance with the European Drinking Water Directive EN 98/83 EC, or latest version.

The water should not be aggressive, i.e. the water chemistry must comply with the following:

- Chloride < 250 mg / L

- Electric Conductivity (EC) @25°C < 750 uS / cm

- Saturation Index (LSI) @80°C > - 1,0 / < 0,8 pH level > 6,0 / < 9,5

The immersion heater has not been exposed to hardness levels exceeding 10°dH (180 ppm CaCO<sub>3</sub>). A water softener is recommended in such cases.

Any disinfection has been carried out without affecting the Product in any way whatsoever. The Product must be isolated from any system chemical disinfecting.

The Product has been in regular use from the date of installation. If the Product is not intended to be used for 60 days or more, it must be drained.

Service and/or repair must be done according to the installation manual and all relevant codes of practice.

Any replacement parts used must be original LG spare parts.

Any third-party costs associated with any claim has been authorized in advance by LG in writing. The purchase invoice and/or installation invoice, a water sample as well as the defective product is made available to LG upon request. Failure to follow these instructions and conditions may result in product failure, and water escaping from the Product.

### 4. Limitations

The warranty does not cover:

Any fault or costs arising from incorrect installation, incorrect application, lack of regular maintenance in accordance with the installation manual, neglect, accidental or malicious damage, misuse, any alteration, tampering or repair carried out by a non-professional, any fault arising from the tampering with or removal of any factory fitted safety components or measures.

Any consequential damage or any indirect loss caused by any failure or malfunction of the Product whatsoever.

Any pipework or any equipment connected to the Product.

The effects of frost, lightning, voltage variation, lack of water, connecting to a non approved external power supply control unit, dry boiling, excess pressure or chlorination procedures.

The effects of stagnant (de-aerated) water if the Product has been left unused for more than 60 days consecutively.

Damage caused during transportation.

Buyer must give the carrier notice of such damage. Costs arising if the Product is not immediately accessible for servicing.

These warranties do not affect the Buyer's statutory rights.

## 5.1 Customer service

In case of problems that cannot be resolved with the aid of the troubleshooting guide in this installation manual, contact either:

- A) The installer who supplied the product.
- B) OSO Hotwater AS: Tel.: +47 32 25 00 00  
oso@oso.no / www.oso.no

## 6. REMOVING THE PRODUCT

### 6.1 Removal

- A) Disconnect the power supply.
- B) Shut off incoming cold water supply.
- C) Empty the product of water – see section 4.4.
- D) Disconnect all pipes.
- E) The product can now be removed.

### 6.2 Returns scheme

This product is recyclable and should be taken to the environmental recycling centre. If the product is to be replaced with a new one, the installer can take the old cylinder away for recycling.



Factory: OSO Hotwater AS  
Industriveien 1, 3300 Hokksund - Norway  
Tel: +47 32 25 00 00  
oso@oso.no  
www.osohotwater.com

**LG Electronics Inc. Single Contact Point (EU):**  
LG Electronics Deutschland GmbH  
Alfred-Herrhausen-Allee 3-5, 65760 Echborn, Germany

**LG Electronics Inc.**  
LG Twin Towers 128 Yeoui-daero, Yeongdeungpo-gu Seoul, 07336, Korea

#### **Eco design requirement**

The information for Eco design is available on the following free access website: <https://www.lg.com/global/support/cedoc/cedoc>