

⊕ : Depending on model / В зависимости от модели / Залежно від моделі / Үлгіге байланысты / Rusumiga qarab / Загвараас хамаарна



www.lg.com

P/No: MFL69649143 (1701-REV00)
Printed in Korea



English

- Read **Safety and Reference**.
- For the power supply and power consumption, refer to the label attached to the product.

Русский

- Прочтите **Руководство по технике безопасности**.
- Требования параметров электропитания и значения потребляемой мощности указаны на информационном лейбле на задней крышке изделия.

Українська

- Прочитайте "**Правила безпеки та довідкова інформація**".
- Відомості щодо подачі живлення і споживання електроенергії дивіться на наліпці на виробі.

Қазақша

- **Қауіпсіздік нұсқаулығын** оқыңыз.
- Электр энергия және тұтыну параметр мәліметтерін өнімдегі жапсырмадан қараңыз.

Ў'zbekcha

- **Xavfsizlik bo'yicha ko'rsatmalar va havolalar** o'qib chiqing.
- Quvvat ta'minoti va quvvat iste'moli uchun mahsulotga yopishtirilgan yorliqqa qarang.

Монгол

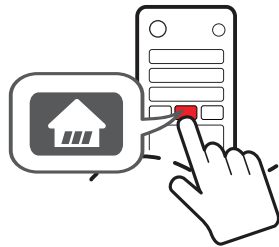

- **Аюулгүй ажиллагааны зааварчилгаа** унш.
- Тэжээл, цахилгаан зарцуулалтын талаарх мэдээллийг бүтээгдэхүүний шошгоос харна уу.

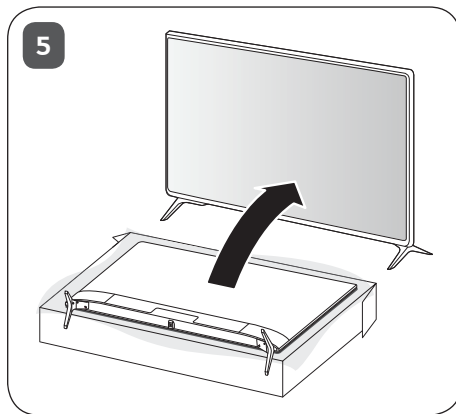
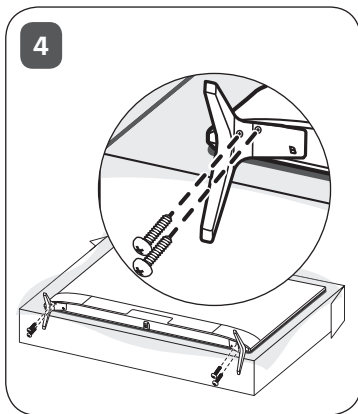
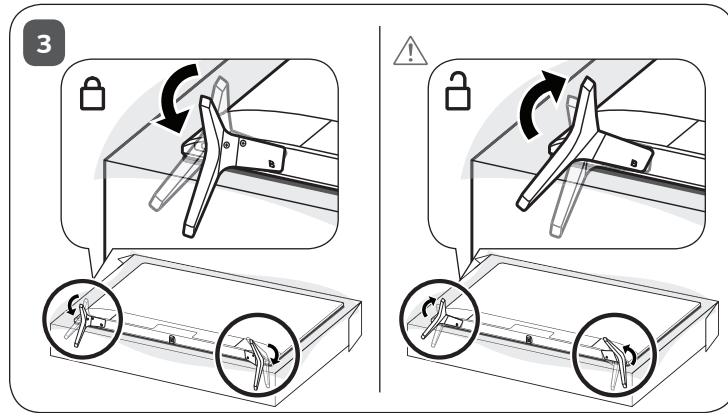
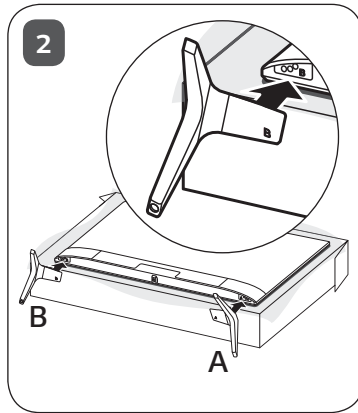

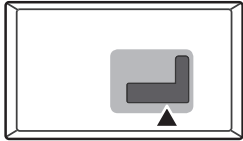



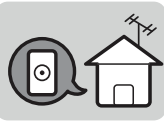
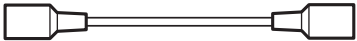



ANTENNA/
CABLE IN

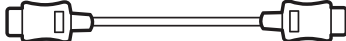



HDMI IN

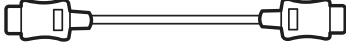



HDMI IN/ARC

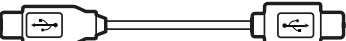

USB IN



LAN

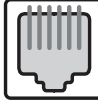

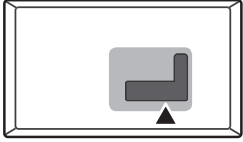

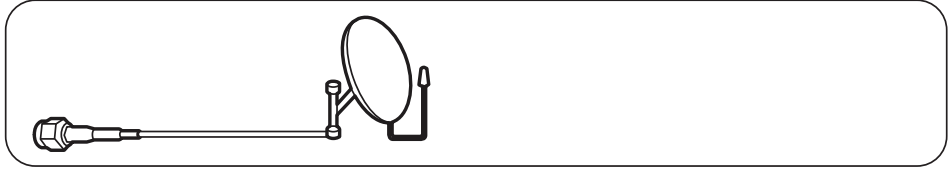

Satellite IN

A circular port with a central hole, representing the Satellite IN port.

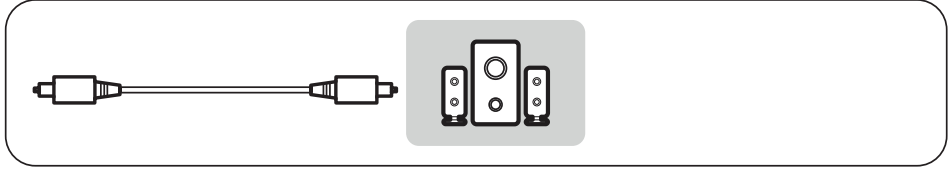
OPTICAL DIGITAL AUDIO OUT

A square port with a small black square in the center, representing the Optical Digital Audio Out port.

PCMCIA CARD SLOT

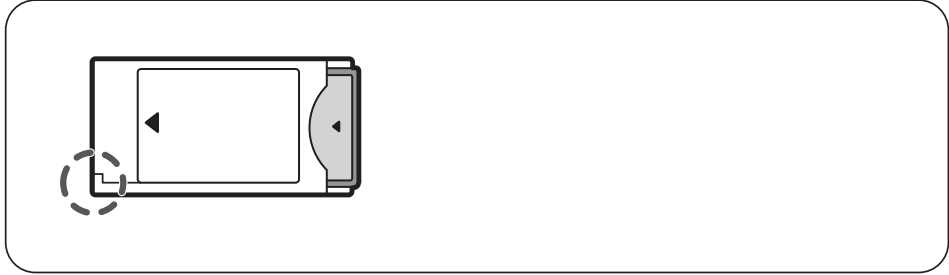
A vertical rectangular slot representing the PCMCIA card slot.

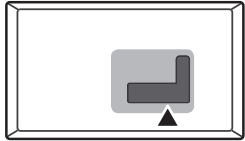

COMPONENT IN

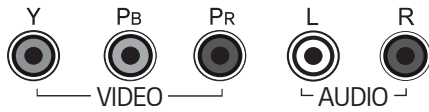
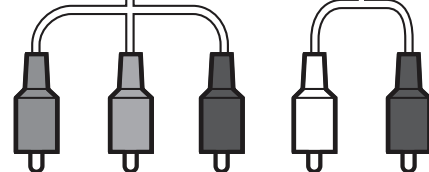
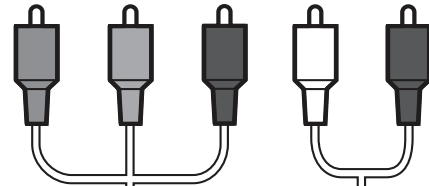
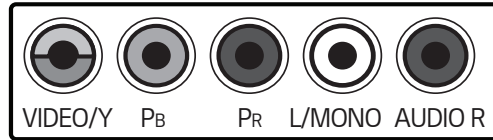

AV IN

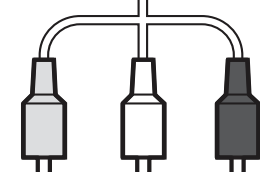
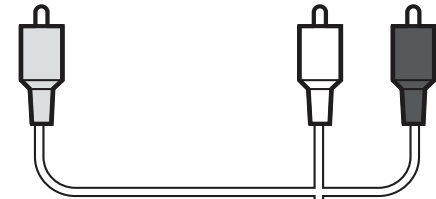
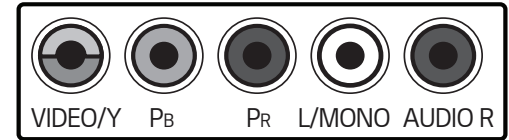

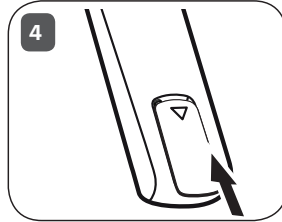
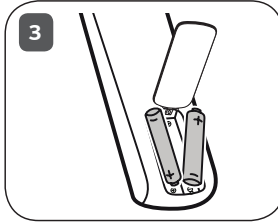
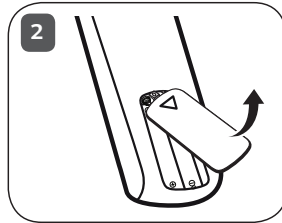
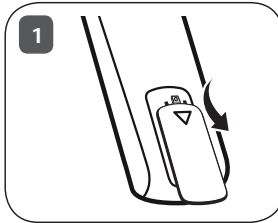
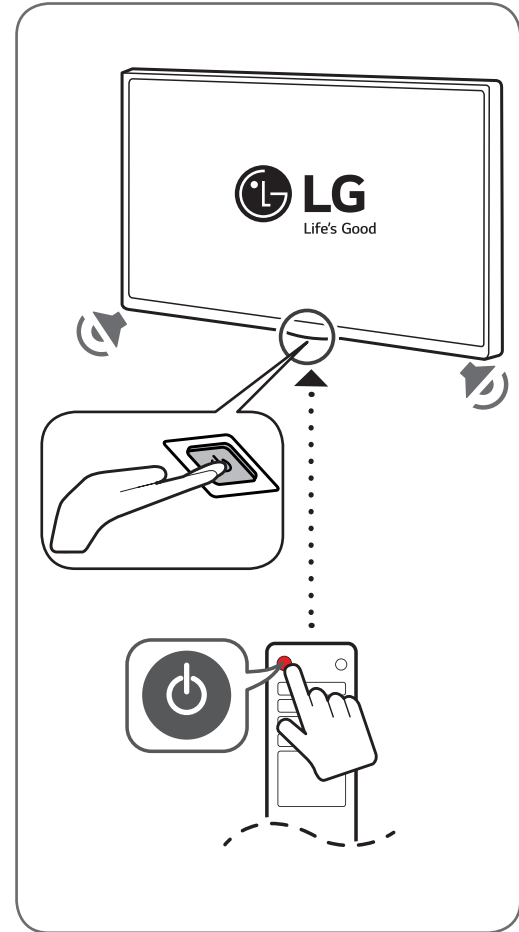
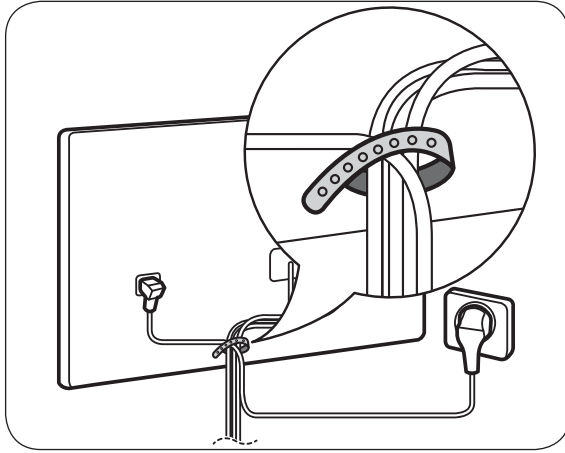

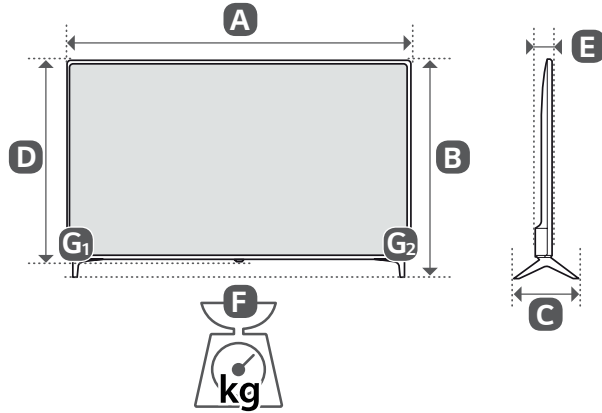

	A (mm)	B (mm)	C (mm)	D (mm)	E (mm)	F (kg)	F - (G ₁ + G ₂) (kg)
43LJ614V-ZA 43LJ610V-ZA	974	625	220	571	79.4	9.3	9.2
49LJ614V-ZA 49LJ610V-ZA	1107	701	235	645	79.4	11.42	11.30
Power requirement				AC 100-240 V ~ 50 / 60 Hz			

(Только для России)

Данные по энергоэффективности для моделей телевизоров LG

* Указанные модели телевизоров не имеют «выключенного режима». Для полного отключения телевизора - отсоедините его от сети питания.

* **Потребляемая мощность изделием в режиме ожидания:** распространяется на заводской режим по умолчанию, только когда функция сетевого режима ожидания отключена.

#: 0~9, A~Z

Модель	Удельная мощность рабочего режима: Вт/см ²	Потребляемая мощность изделием в режиме ожидания: Вт	Потребляемая мощность изделием в выключенном режиме
43LJ61#V-ZA	0.018	0.3	отсутствует
49LJ61#V-ZA	0.015	0.3	отсутствует





MFL69649143