



INSTALLATION MANUAL

AIR CONDITIONER

Please read this installation manual completely before installing the product. Installation work must be performed in accordance with the national wiring standards by authorized personnel only. Please retain this installation manual for future reference after reading it thoroughly.

MULTI V[™] i

For Heat Pump / Heat Recovery system

Original instruction



MFL71987502
Rev.04_112025



www.lg.com

Copyright © 2023 - 2025 LG Electronics Inc. All Rights Reserved.

UKPAЙHCBKA	PORTUGUÊS	ENGLISH
ҚАЗАҚ ТІЛІ	MAGYAR	ITALIANO
БЕЛАРУСКАЯ МОВА	БЪЛГАРСКИ	ESPAÑOL
ЎЗБЕК ТИЛИ	SRPSKI	FRANÇAIS
	HRVATSKI	DEUTSCH
	SVENSKA	EAHNIKA
	NORSK	ČEŠTINA
	SUOMI	NEDERLANDS
	DANSK	POLSKI
	РУССКИЙ ЯЗЫК	LIMBA ROMÂNĂ

TIPS FOR SAVING ENERGY

Here are some tips that will help you minimize the power consumption when you use the air conditioner. You can use your air conditioner more efficiently by referring to the instructions below:

- Do not cool excessively indoors. This may be harmful for your health and may consume more electricity.
- Block sunlight with blinds or curtains while you are operating the air conditioner.
- Keep doors or windows closed tightly while you are operating the air conditioner.
- Adjust the direction of the air flow vertically or horizontally to circulate indoor air.
- Speed up the fan to cool or warm indoor air quickly, in a short period of time.
- Open windows regularly for ventilation as the indoor air quality may deteriorate if the air conditioner is used for many hours.
- Clean the air filter once every 2 weeks. Dust and impurities collected in the air filter may block the air flow or weaken the cooling / dehumidifying functions.

For your records

Staple your receipt to this page in case you need it to prove the date of purchase or for warranty purposes.

Write the model number and the serial number here:

Model number : _____

Serial number : _____

You can find them on a label on the side of each unit.

Dealer's name : _____

Date of purchase : _____

IMPORTANT SAFETY INSTRUCTIONS

READ ALL INSTRUCTIONS BEFORE USING THE APPLIANCE.

Always comply with the following precautions to avoid dangerous situations and ensure peak performance of your product.

⚠ WARNING

It can result in serious injury or death when the directions are ignored.

⚠ CAUTION

It can result in minor injury or product damage when the directions are ignored.

⚠ WARNING

- Installation or repairs made by unqualified persons can result in hazards to you and others.
- The information contained in the manual is intended for use by a qualified service technician familiar with safety procedures and equipped with the proper tools and test instruments.
- Failure to carefully read and follow all instructions in this manual can result in equipment malfunction, property damage, personal injury and/or death.
- If the supply cord is damaged, it must be replaced by the manufacturer, its service agent or similarly qualified persons in order to avoid a hazard.

Installation

- Have all electric work done by a licensed electrician according to "Electric Facility Engineering Standard" and "Interior Wire Regulations" and the instructions given in this manual and always use a special circuit.
 - If the power source capacity is inadequate or electric work is performed improperly, electric shock or fire may result.
- Ask the dealer or an authorized technician to install the air conditioner.
 - Improper installation by the user may result in water leakage, electric shock, or fire.
- Always ground the product.
 - There is risk of fire or electric shock.
- Always install a dedicated circuit and breaker.
 - Improper wiring or installation may cause fire or electric shock.
- For re-installation of the installed product, always contact a dealer or an Authorized Service Center.
 - There is risk of fire, electric shock, explosion, or injury.
- Do not install, remove, or re-install the unit by yourself (customer).
 - There is risk of fire, electric shock, explosion, or injury.

- Do not store or use flammable gas or combustibles near the air conditioner.
 - There is risk of fire or failure of product.
- Use the correctly rated breaker or fuse.
 - There is risk of fire or electric shock.
- Prepare for strong wind or earthquake and install the unit at the specified place.
 - Improper installation may cause the unit to topple and result in injury.
- Do not install the product on a defective installation stand.
 - It may cause injury, accident, or damage to the product.
- Use a vacuum pump or Inert(nitrogen) gas when doing leakage test or air purge. Do not compress air or Oxygen and do not use Flammable gases. Otherwise, it may cause fire or explosion.
 - There is the risk of death, injury, fire or explosion.
- When installing and moving the air conditioner to another site, do not charge it with a different refrigerant from the refrigerant specified on the unit.
 - If a different refrigerant or air is mixed with the original refrigerant, the refrigerant cycle may malfunction and the unit may be damaged.
- Do not reconstruct to change the settings of the protection devices.
 - If the pressure switch, thermal switch, or other protection device is shorted and operated forcibly, or parts other than those specified by LGE are used, fire or explosion may result.
- Ventilate before operating air conditioner when gas leaked out.
 - It may cause explosion, fire, and burn.
- Securely install the cover of control box and the panel.
 - If the cover and panel are not installed securely, dust or water may enter the outdoor unit and fire or electric shock may result.

- If the air conditioner is installed in a small room, measures must be taken to prevent the refrigerant concentration from exceeding the safety limit when the refrigerant leaks.
 - Consult the dealer regarding the appropriate measures to prevent the safety limit from being exceeded. Should the refrigerant leak and cause the safety limit to be exceeded, hazards due to lack of oxygen in the room could result.

Operation

- Do not damage or use an unspecified power cord.
 - There is risk of fire, electric shock, explosion, or injury.
- Use a dedicated outlet for this appliance.
 - There is risk of fire or electrical shock.
- Be cautious that water could not enter the product.
 - There is risk of fire, electric shock, or product damage.
- Do not touch the power switch with wet hands.
 - There is risk of fire, electric shock, explosion, or injury.
- When the product is soaked (flooded or submerged), contact an Authorized Service Center.
 - There is risk of fire or electric shock.
- Be cautious not to touch the sharp edges when installing.
 - It may cause injury.
- Take care to ensure that nobody could step on or fall onto the outdoor unit.
 - This could result in personal injury and product damage.
- Do not open the inlet grille of the product during operation. (Do not touch the electrostatic filter, if the unit is so equipped.)
 - There is risk of physical injury, electric shock, or product failure.

⚠ CAUTION**Installation**

- Always check for gas (refrigerant) leakage after installation or repair of product.
 - Low refrigerant levels may cause failure of product.
- Do not install the product where the noise or hot air from the outdoor unit could damage the neighborhoods.
 - It may cause a problem for your neighbors.
- Keep level even when installing the product.
 - To avoid vibration or water leakage.
- Do not install the unit where combustible gas may leak.
 - If the gas leaks and accumulates around the unit, an explosion may result.
- Use power cables of sufficient current carrying capacity and rating.
 - Cables that are too small may leak, generate heat, and cause a fire.
- Do not use the product for special purposes, such as preserving foods, works of art, etc. It is a consumer air conditioner, not a precision refrigeration system.
 - There is risk of damage or loss of property.
- Keep the unit away from children. The heat exchanger is very sharp.
 - It can cause the injury, such as cutting the finger. Also the damaged fin may result in degradation of capacity.
- When installing the unit in a hospital, communication station, or similar place, provide sufficient protection against noise.
 - The inverter equipment, private power generator, high-frequency medical equipment, or radio communication equipment may cause the air conditioner to operate erroneously, or fail to operate. On the other hand, the air conditioner may affect such equipment by creating noise that disturbs medical treatment or image broadcasting.

- Do not install the product where it is exposed to sea wind (salt spray) directly.
 - It may cause corrosion on the product. Corrosion, particularly on the condenser and evaporator fins, could cause product malfunction or inefficient operation.
- Do not install the unit in potentially explosive atmospheres.

Operation





- Do not use the air conditioner in special environments.
 - Oil, steam, sulfuric smoke, etc. can significantly reduce the performance of the air conditioner or damage its parts.
- Do not block the inlet or outlet.
 - It may cause failure of appliance or accident.
- Make the connections securely so that the outside force of the cable may not be applied to the terminals.
 - Inadequate connection and fastening may generate heat and cause a fire.
- Be sure the installation area does not deteriorate with age.
 - If the base collapses, the air conditioner could fall with it, causing property damage, product failure, or personal injury.
- Install and insulate the drain hose to ensure that water is drained away properly based on the installation manual.
 - A bad connection may cause water leakage.
- Be very careful about product transportation.
 - Only one person should not carry the product if it weighs more than 20 kg.
 - Some products use PP bands for packaging. Do not use any PP bands for a means of transportation. It is dangerous.
 - Do not touch the heat exchanger fins. Doing so may cut your fingers.
 - When transporting the outdoor unit, suspending it at the specified positions on the unit base. Also support the outdoor unit at four points so that it cannot slip sideways.

- Safely dispose of the packing materials.
 - Packing materials, such as nails and other metal or wooden parts, may cause stabs or other injuries.
 - Tear apart and throw away plastic packaging bags so that children may not play with them. If children play with a plastic bag which was not torn apart, they face the risk of suffocation.
- Turn on the power at least 6 hours before starting operation.
 - Starting operation immediately after turning on the main power switch can result in severe damage to internal parts. Keep the power switch turned on during the operational season.
- Do not touch any of the refrigerant piping during and after operation.
 - It can cause a burn or frostbite.
- Do not operate the air conditioner with the panels or guards removed.
 - Rotating, hot, or high-voltage parts can cause injuries.
- Do not directly turn off the main power switch after stopping operation.
 - Wait at least 5 minutes before turning off the main power switch. Otherwise it may result in water leakage or other problems.
- Auto-addressing should be done in condition of connecting the power of all indoor and outdoor units. Auto-addressing should also be done in case of changing the indoor unit PCB.
- Use a firm stool or ladder when cleaning or maintaining the air conditioner.
 - Be careful and avoid personal injury.
- Do not insert hands or other objects through the air inlet or outlet while the air conditioner is plugged in.
 - There are sharp and moving parts that could cause personal injury.
- Means for disconnection must be incorporated in the fixed wiring in accordance with the wiring rules.
- Mechanical connections (mechanical connectors or flared joints) shall be accessible for maintenance purposes. Pipe-work shall be protected from physical damage.

When mechanical connectors are reused indoors, sealing parts shall be renewed. When flared joints are reused indoors, the flare part shall be re-fabricated. The appliance shall be installed in accordance with national wiring regulations. For installations with field applied mechanical joints which are exposed in the occupied space, the instructions shall state that a sensor shall be located
- Remote located within 2 m horizontal distance in line of sight of the unit and on a wall within the room in which the unit is installed; and
 - 100 mm above the floor where h_0 is not more than 300 mm from the floor: or
 - 300 mm above the floor where h_0 is greater than 300 mm from the floor.

The supply and return air shall be directly ducted to the space. Open areas such as false ceilings shall not be used as a return air duct. servicing shall be performed only as recommended by the manufacturer.

Safety precautions for R32 model

	This appliance is filled with flammable refrigerant (for R32)
	This symbol indicates that the Operation Manual should be read carefully.
	This symbol indicates that a service personnel should be handling this equipment with reference to the Installation Manual.
	Read the precautions in this manual carefully before operating the unit.

- Do not use means to accelerate the defrosting process or to clean, other than those recommended by the manufacturer.
- The appliance shall be stored in a room without continuously operating ignition sources (for example: open flames, an operating gas appliance or an operating electric heater.)
- Do not pierce or burn.
- Be aware that refrigerants may not contain an odour.
- Keep any required ventilation openings clear of obstruction
- Auxiliary devices which may be a potential ignition source shall not be installed in the duct work. Examples of such potential ignition sources are hot surfaces with a temperature exceeding X°C and electric switching devices.
- Only auxiliary devices approved by the appliance manufacturer or declared suitable with the refrigerant shall be installed in connecting ductwork.
- The appliance shall be stored so as to prevent mechanical damage from occurring. The manufacturer should specify other potential continuously operating sources known to cause ignition of the refrigerant used.
- Compliance with national gas regulations shall be observed
- Refrigerant tubing shall be protected or enclosed to avoid damage.
- The installation of pipe-work shall be kept to a minimum
- A brazed, welded, or mechanical connection shall be made before opening the valves to permit refrigerant to flow between the refrigerating system parts.
- Any person who is involved with working on or breaking into a refrigerant circuit should hold a current valid certificate from an industry-accredited assessment authority, which authorises their competence to handle refrigerants safely in accordance with an industry recognised assessment specification.
- Servicing shall only be performed as recommended by the equipment manufacturer. Maintenance and repair requiring the assistance of other skilled personnel shall be carried out under the supervision of the person competent in the use of flammable refrigerants.
- Periodic cleaning of the dust of salt particles stuck on the heat exchanger by using water.
- Dismantling the unit, treatment of the refrigerant oil and eventual parts should be done in accordance with local and national standards.
- **Checks to the area**
Prior to beginning work on systems containing flammable refrigerants, safety checks are necessary to ensure that the risk of ignition is minimised. For repair to the refrigerating system, the following precautions shall be complied with prior to conducting work on the system.
- **Work procedure**
Work shall be undertaken under a controlled procedure so as to minimise the risk of a flammable gas or vapour being present while the work is being performed.

- **General work area**

All maintenance staff and others working in the local area shall be instructed on the nature of work being carried out. Work in confined spaces shall be avoided.

- **Checking for presence of refrigerant**

The area shall be checked with an appropriate refrigerant detector prior to and during work, to ensure the technician is aware of potentially flammable atmospheres. Ensure that the leak detection equipment being used is suitable for use with flammable refrigerants, i.e. non-sparking, adequately sealed or intrinsically safe.

- **Presence of fire extinguisher**

If any hot work is to be conducted on the refrigerating equipment or any associated parts, appropriate fire extinguishing equipment shall be available to hand. Have a dry powder or CO₂ fire extinguisher adjacent to the charging area.

- **No ignition sources**

No person carrying out work in relation to a refrigerating system which involves exposing any pipe work that contains or has contained flammable refrigerant shall use any sources of ignition in such a manner that it may lead to the risk of fire or explosion.

All possible ignition sources, including cigarette smoking, should be kept sufficiently far away from the site of installation, repairing, removing and disposal, during which flammable refrigerant can possibly be released to the surrounding space.

Prior to work taking place, the area around the equipment is to be surveyed to make sure that there are no flammable hazards or ignition risks. "No Smoking" signs shall be displayed.

- **Checks to the refrigerating equipment**

Where electrical components are being changed, they shall be fit for the purpose and to the correct specification. At all times the manufacturer's maintenance and service guidelines shall be followed. If in doubt consult the manufacturer's technical department for assistance.

The following checks shall be applied to installations using flammable refrigerants:

- The actual refrigerant charge is in accordance with the room size within which the refrigerant containing parts are installed
- The ventilation machinery and outlets are operating adequately and are not obstructed
- If an indirect refrigerating circuit is being used, the secondary circuit shall be checked for the presence of refrigerant
- Marking to the equipment continues to be visible and legible. Markings and signs that are illegible shall be corrected
- Refrigerating pipe or components are installed in a position where they are unlikely to be exposed to any substance which may corrode refrigerant containing components, unless the components are constructed of materials which are inherently resistant to being corroded or are suitably protected against being so corroded.

- **Checks to electrical devices**

Repair and maintenance to electrical components shall include initial safety checks and component inspection procedures. If a fault exists that could compromise safety, then no electrical supply shall be connected to the circuit until it is satisfactorily dealt with. If the fault cannot be corrected immediately but it is necessary to continue operation, an adequate temporary solution shall be used. This shall be reported to the owner of the equipment so all parties are advised.

Initial safety checks shall include:

- Capacitors are discharged: this shall be done in a safe manner to avoid possibility of sparking.
- No live electrical components and wiring are exposed while charging, recovering or purging the system.
- Continuity of earth bonding

- **Repairs to sealed components**

During repairs to sealed components, all electrical supplies shall be disconnected from the equipment being worked upon prior to any removal of sealed covers, etc.

If it is absolutely necessary to have an electrical supply to equipment during servicing, then a permanently operating form of leak detection shall be located at the most critical point to warn of a potentially hazardous situation.

Particular attention shall be paid to the following to ensure that by working on electrical components, the casing is not altered in such a way that the level of protection is affected.

This shall include damage to cables, excessive number of connections, terminals not made to original specification, damage to seals, incorrect fitting of glands, etc.

Ensure that apparatus is mounted securely.

Ensure that seals or sealing materials have not degraded such that they no longer serve the purpose of preventing the ingress of flammable atmospheres.

Replacement parts shall be in accordance with the manufacturer's specifications.

- **Repair to intrinsically safe components**

Do not apply any permanent inductive or capacitance loads to the circuit without ensuring that this will not exceed the permissible voltage and current permitted for the equipment in use.

Intrinsically safe components are the only types that can be worked on while live in the presence of a flammable atmosphere.

The test apparatus shall be at the correct rating. Replace components only with parts specified by the manufacturer.

Other parts may result in the ignition of refrigerant in the atmosphere from a leak.

NOTE: The use of silicon sealant can inhibit the effectiveness of some types of leak detection equipment. Intrinsically safe components do not have to be isolated prior to working on them.

- **Decommissioning**

Before carrying out this procedure, it is essential that the technician is completely familiar with the equipment and all its detail. It is recommended good practice that all refrigerants are recovered safely.

Prior to the task being carried out, an oil and refrigerant sample shall be taken in case analysis is required prior to re-use of recovered refrigerant. It is essential that electrical power is available before the task is commenced.

- a) Become familiar with the equipment and its operation.
- b) Isolate system electrically.
- c) Before attempting the procedure ensure that:
 - Mechanical handling equipment is available, if required, for handling refrigerant cylinders
 - All personal protective equipment is available and being used correctly
 - The recovery process is supervised at all times by a competent person
 - Recovery equipment and cylinders conform to the appropriate standards.
- d) Pump down refrigerant system, if possible.
- e) If a vacuum is not possible, make a manifold so that refrigerant can be removed from various parts of the system.
- f) Make sure that cylinder is situated on the scales before recovery takes place.
- g) Start the recovery machine and operate in accordance with manufacturer's instructions.
- h) Do not overfill cylinders. (No more than 80 % volume liquid charge).
- i) Do not exceed the maximum working pressure of the cylinder, even temporarily.
- j) When the cylinders have been filled correctly and the process completed, make sure that the cylinders and the equipment are removed from site promptly and all isolation valves on the equipment are closed off.
- k) Recovered refrigerant shall not be charged into another refrigerating system unless it has been cleaned and checked.

- **Labelling**

Equipment shall be labelled stating that it has been de-commissioned and emptied of refrigerant. The label shall be dated and signed. Ensure that there are labels on the equipment stating the equipment contains flammable refrigerant.

- **Ventilated area**

Ensure that the area is in the open or that it is adequately ventilated before breaking into the system or conducting any hot work. A degree of ventilation shall continue during the period that the work is carried out. The ventilation should safely disperse any released refrigerant and preferably expel it externally into the atmosphere.

- **Cablling**

Cablling will not be subject to wear, corrosion, excessive pressure, vibration, sharp edges or any other adverse environmental effects. The check shall also take into account the effects of ageing or continual vibration from sources such as compressors or fans.

- **Detection of flammable refrigerants**

Under no circumstances shall potential sources of ignition be used in the searching for or detection of refrigerant leaks. A halide torch (or any other detector using a naked flame) shall not be used.

- **Leak detection methods**

The following leak detection methods are deemed acceptable for systems containing flammable refrigerants.

Electronic leak detectors shall be used to detect flammable refrigerants, but the sensitivity may not be adequate, or may need re-calibration. (Detection equipment shall be calibrated in a refrigerant-free area.)

Ensure that the detector is not a potential source of ignition and is suitable for the refrigerant used.

Leak detection equipment shall be set at a percentage of the LFL of the refrigerant and shall be calibrated to the refrigerant employed and the appropriate percentage of gas (25 % maximum) is confirmed.

Leak detection fluids are also suitable for use with most refrigerants but the use of detergents containing chlorine shall be avoided as the chlorine may react with the refrigerant and corrode the copper pipe-work.

NOTE: Examples of leak detection fluids are

- bubble method
- fluorescent method agents

If a leak is suspected, all naked flames shall be removed/extinguished.

If a leakage of refrigerant is found which requires brazing, all of the refrigerant shall be recovered from the system, or isolated (by means of shut off valves) in a part of the system remote from the leak. Removal of refrigerant shall be according to removal and evacuation procedure.

- **Removal and evacuation**

When breaking into the refrigerant circuit to make repairs - or for any other purpose – conventional procedures shall be used. However, for flammable refrigerants it is important that best practice is followed since flammability is a consideration.

The following procedure shall be adhered to:

- Remove refrigerant;
- Purge the circuit with inert gas (optional for A2L);
- Evacuate (optional for A2L);
- Purge with inert gas (optional for A2L);
- Open the circuit by cutting or brazing

The refrigerant charge shall be recovered into the correct recovery cylinders. For appliances containing flammable refrigerants other than A2L refrigerants, the system shall be purged with oxygen-free nitrogen to render the appliance safe for flammable refrigerants. This process may need to be repeated several times.

Compressed air or oxygen shall not be used for purging refrigerant systems.

For appliances containing flammable refrigerants, other than A2L refrigerants, refrigerants purging shall be achieved by breaking the vacuum in the system with oxygen-free nitrogen and continuing to fill until the working pressure is achieved, then venting to atmosphere, and finally pulling down to a vacuum. This process shall be repeated until no refrigerant is within the system. When the final oxygen-free nitrogen charge is used, the system shall be vented down to atmospheric pressure to enable work to take place. This operation is absolutely vital if brazing operations on the pipe-work are to take place.

Ensure that the outlet for the vacuum pump is not close to any potential ignition sources and that ventilation is available.

• Charging procedures

In addition to conventional charging procedures, the following requirements shall be followed.

- Ensure that contamination of different refrigerants does not occur when using charging equipment. Hoses or lines shall be as short as possible to minimise the amount of refrigerant contained in them.
- Cylinders shall be kept in an appropriate position according to the instruction.
- Ensure that the refrigerating system is earthed prior to charging the system with refrigerant.
- Label the system when charging is complete (if not already).
- Extreme care shall be taken not to overfill the refrigerating system.

Prior to recharging the system, it shall be pressure tested with the appropriate purging gas. The system shall be leak-tested on completion of charging but prior to commissioning. A follow up leak test shall be carried out prior to leaving the site.

• Recovery

When removing refrigerant from a system, either for servicing or decommissioning, it is recommended good practice that all refrigerants are removed safely.

When transferring refrigerant into cylinders, ensure that only appropriate refrigerant recovery cylinders are employed.

Ensure that the correct number of cylinders for holding the total system charge are available. All cylinders to be used are designated for the recovered refrigerant and labelled for that refrigerant (i.e. special cylinders for the recovery of refrigerant).

Cylinders shall be complete with pressure relief valve and associated shut-off valves in good working order.

Empty recovery cylinders are evacuated and, if possible, cooled before recovery occurs.

The recovery equipment shall be in good working order with a set of instructions concerning the equipment that is at hand and shall be suitable for the recovery of flammable refrigerants. In addition, a set of calibrated weighing scales shall be available and in good working order.

Hoses shall be complete with leak-free disconnect couplings and in good condition. Before using the recovery machine, check that it is in satisfactory working order, has been properly maintained and that any associated electrical components are sealed to prevent ignition in the event of a refrigerant release.

Consult manufacturer if in doubt. The recovered refrigerant shall be returned to the refrigerant supplier in the correct recovery cylinder, and the relevant Waste Transfer Note arranged.

Do not mix refrigerants in recovery units and especially not in cylinders. If compressors or compressor oils are to be removed, ensure that they have been evacuated to an acceptable level to make certain that flammable refrigerant does not remain within the lubricant.

The evacuation process shall be carried out prior to returning the compressor to the suppliers. Only electric heating to the compressor body shall be employed to accelerate this process. When oil is drained from a system, it shall be carried out safely.

- **Qualification of workers**

The manual shall contain specific information about the required qualification of the working personnel for maintenance, service and repair operations. Every working procedure that affects safety means shall only be carried out by competent persons according to Annex HH.

Examples for such working procedures are:

- breaking into the refrigerating circuit;
- opening of sealed components;
- opening of ventilated enclosures.

TABLE OF CONTENTS

2 TIPS FOR SAVING ENERGY

2 IMPORTANT SAFETY INSTRUCTIONS

13 INSTALLATION PROCESS

13 OUTDOOR UNITS INFORMATION

13 SELECT THE BEST LOCATION

15 INSTALLATION SPACE

15 Individual Installation

15 LIFTING METHOD

16 INSTALLATION

16 The location of the Anchor bolts

16 Foundation for Installation

17 Preparation of Piping

18 Plumbing materials and storage methods

19 REFRIGERANT PIPING INSTALLATION

<For Heat Pump System Installation>

19 Precautions on Pipe connection / Valve operation

19 Caution

<For Heat Recovery System Installation>

20 Precautions on Pipe connection / Valve operation

20 Installation procedure for HR unit

21 Installation of Outdoor Unit, HR Unit, Indoor Unit Refrigerant Pipe

21 Type of HR Unit

21 Installation of Zoning Control

22 Caution

23 PIPE CONNECTIONS BETWEEN INDOOR AND OUTDOOR UNIT

<For Heat Pump System Installation>

23 Preparation Work

23 Pipe Drawing Out during Single / Series connection

24 Refrigerant piping system

<For Heat Recovery System Installation>

24 Preparation Work

25 Pipe Drawing Out during Single / Series connection

25 Refrigerant piping system

<For Heat Pump And Heat Recovery System Installation>

28 Pipe Connection Method between outdoor unit/indoor unit

29 Branch pipe Fitting

31 Distribution Method

31 Vacuum Mode

32 Leak Test and Vacuum drying

33 Refrigerant charging

34 Thermal insulation of refrigerant piping

35 ELECTRICAL WIRING

35 Caution

36 Control box and connecting position of wiring

36 Communication and Power Cables

36 Separation of communication and power cables

37 Wiring of main power supply and equipment capacity

37 Field Wiring

39 Checking the setting of outdoor units

40 Setting For Heat Recovery Unit

40 Switch for setup of HR Unit

42 Automatic Addressing

43 The Procedure of Automatic Addressing

44 Flow chart of auto pipe detection process

44 Flow chart of manual addressing for pipe detection

44 Group Number setting

45 Cool & Heat selector

46 High Static Pressure Compensation mode

46 Night Low Noise Function

46 Overall defrost mode

46 Setting the ODU address

47 Snow removal & rapid defrost

47 Setting Capacity Up Airflow Adjusting for IDU (Heating)

47 Target pressure adjusting

48 Low Ambient Kit

48 Auto Dust Removal Mode

48 Compressor Max. Frequency Limit

49 ODU Fan Max. RPM Limit

49 SLC (Smart Load Control)

49 Humidity Reference

49 Central Control Connection at Indoor Unit side

50 Compressor Input Current Limit

50 Power Consumption Display on wired remote controller

50 Overall Defrost Operating in Low temperature (Heating)

51 Base pan Heater operation

51 Target Noise Control

51 Comfort Cooling operation

52 LG AI engine connection information setting option

52 LG AI engine function

60 Self-Diagnosis Function

63 SPECIAL REQUIREMENTS

63 Flow chart

66 INSTALLATION GUIDE AT THE SEASIDE

66 Model Designation

66 Airborne Noise Emission

INSTALLATION PROCESS

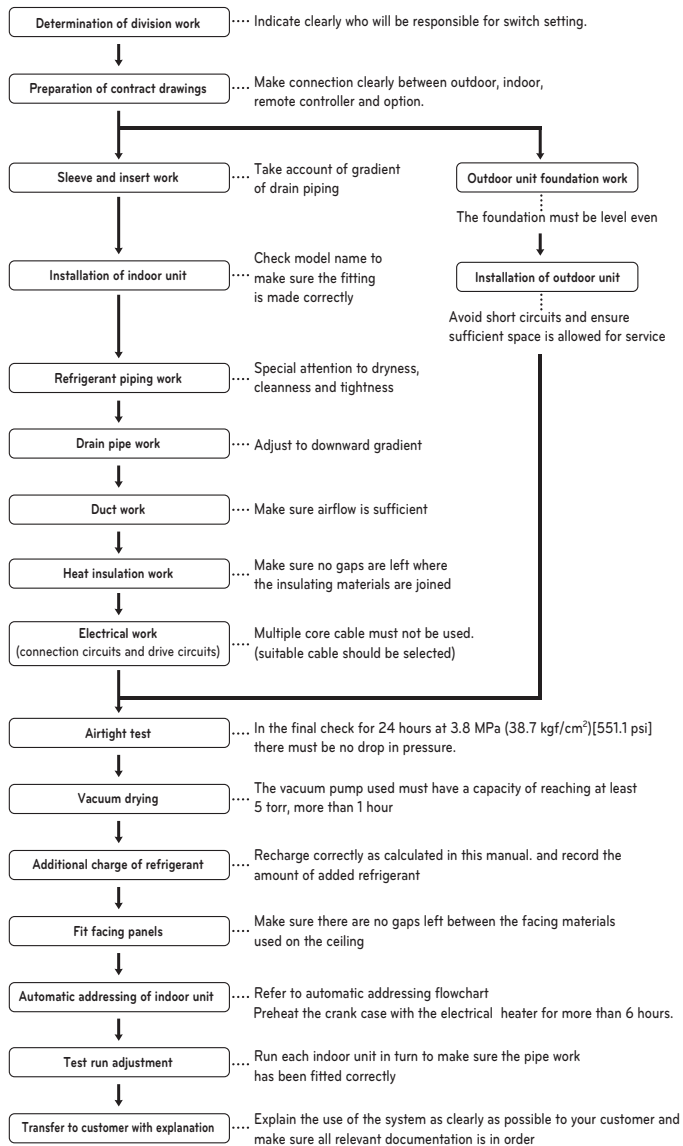

CAUTION

- The above list indicates the order in which the individual work operations are normally carried out but this order may be varied where local conditions warrants such change.
- The thickness of the piping should comply with the relevant local and national regulations for the designed pressure 3.8 MPa (551.1 psi).

OUTDOOR UNITS INFORMATION

CAUTION

Combination Ratio(50~200 %)

Outdoor Number	Connection Ratio
Single outdoor units	200 %

Notes : * We can guarantee the operation only within 130 % combination. If you want to connect more than 130 % combination, please contact us and discuss the requirement like below.

- If the operation of indoor unit is more than 130 %, the airflow is operated as low in the all indoor units.

CAUTION

- The wall thickness of the piping should comply with the relevant local and national regulations for the designed pressure 3.8 MPa [551.1 psi]
- Do not place the refrigerant container under the direct rays of the sun to prevent it from exploding.
- For high-pressure refrigerant, any unapproved pipe must not be used.
- Do not heat pipes more than necessary to prevent them from softening.

SELECT THE BEST LOCATION

Select space for installing outdoor unit, which will meet the following conditions:

- No direct thermal radiation from other heat sources
- No possibility of annoying neighbors due to noise of unit
- No exposition to strong wind
- With strength which bears weight of unit
- Note that drain flows out of unit when heating
- Because of the possibility of fire, do not install unit to the space where generation, inflow, stagnation, and leakage of combustible gas is expected.
- Avoid unit installation in a place where acidic solution and spray (sulfur) are often used.
- Do not use unit under any special environment where oil, steam and sulfuric gas exist.
- It is recommended to fence round the outdoor unit in order to prevent any person or animal from accessing the outdoor unit.
- If installation site is area of heavy snowfall, then the following directions should be observed.
 - Make the foundation as high as possible.
 - Fit a snow protection hood.
- Select installation location considering following conditions to avoid bad condition when additionally performing defrost operation.
 - Install the outdoor unit at a place well ventilated and having a lot of sunshine in case of installing the product at a place With a high humidity in winter (near beach, coast, lake, etc.) (Ex : Rooftop where there is always sunshine.)

For Heat Recovery Installation

Select installation location of the HR unit suitable for following conditions

- Avoid a place where rain may enter since the HR unit is for indoor.
- Sufficient service space must be obtained.
- Refrigerant pipe must not exceed limited length.
- Avoid a place subject to a strong radiation heat from other heat source.
- Avoid a place where oil spattering, vapor spray or high frequency electric noise is expected.
- Install the unit at a place in which it is not affected by operation noise. (Installation within cell such as meeting room etc. may disturb business due to noise.)
- Place where refrigerant piping, drain piping and electrical wiring works are easy.

2 port / 3port / 4 port HR unit

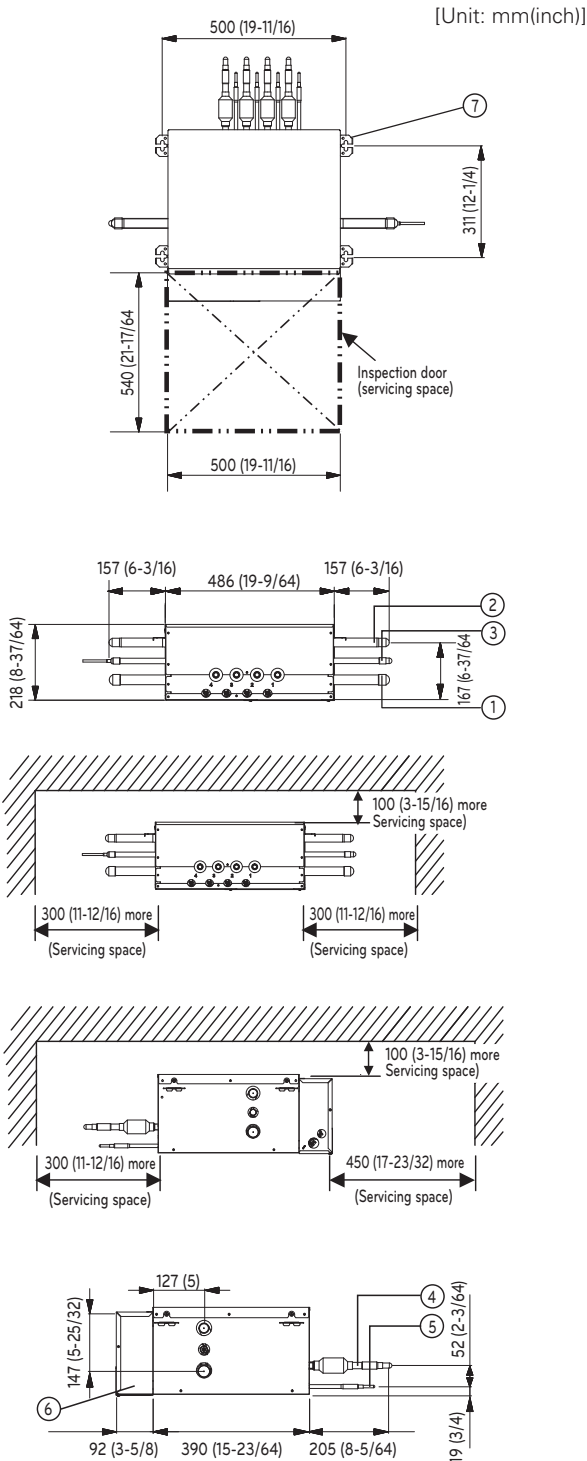

6 port / 8 port HR unit

[Unit: mm(inch)]

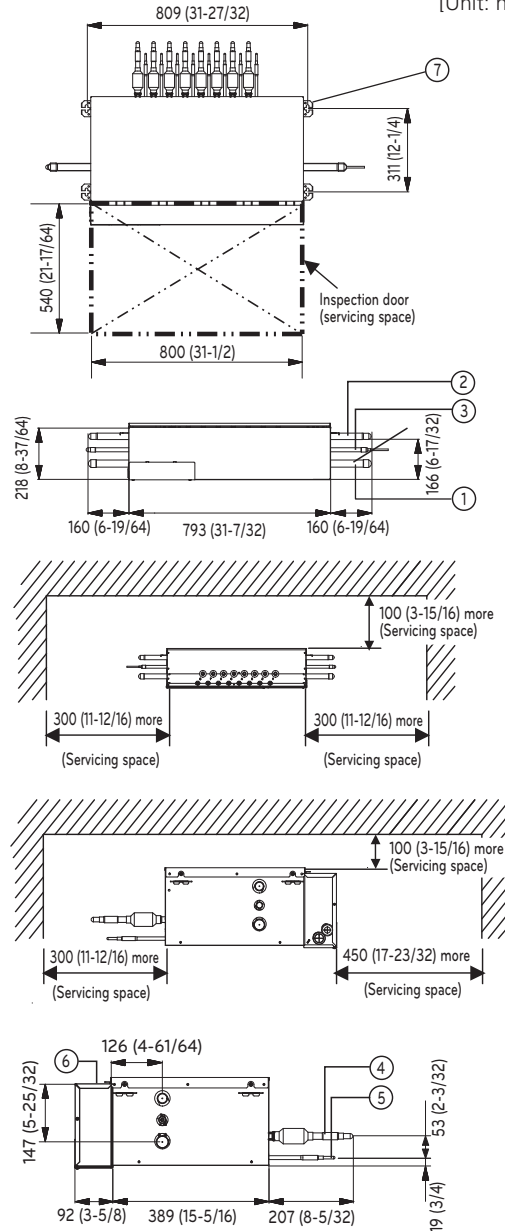

[Unit: mm(inch)]

No.	Part Name	Type of HR unit	
		3 port / 4 port 6 port / 8 port	2 port
Description			
1	Low pressure Gas pipe connection port	Ø 28.58 (1-1/8) Brazing connection	Ø 22.2 (7/8) Brazing connection
2	High pressure Gas pipe connection port	Ø 22.2 (7/8) Brazing connection	Ø 19.05 (3/4) Brazing connection
3	Liquid pipe connection port	Ø 15.88 (5/8) Brazing connection (In a type of 3 port HR unit, use Ø12.7 (1/2))	Ø 9.52 (3/8) Brazing connection
4	Indoor unit Gas pipe connection port	Ø 15.88 (5/8) - Ø 12.7 (1/2) Brazing connection	Ø 15.88 (5/8) - Ø 12.7 (1/2) Brazing connection
5	Indoor unit Liquid pipe connection port	Ø 9.52 (3/8) - Ø 6.35 (1/4) Brazing connection	Ø 9.52 (3/8) - Ø 6.35 (1/4) Brazing connection
6	Control box	-	-
7	Hanger metal	Suspension bolt M10 or M8	Suspension bolt M10 or M8

NOTE

- Be sure to install the inspection door at the control box side.
- If reducers are used, servicing space must be increased equal to reducer's dimension.

INSTALLATION SPACE

Individual Installation

During the installation of the unit, consider service, inlet, and outlet acquire the minimum space as shown in the figures below.

[Unit : mm (inch)]

Category	Installation Space	Case 1 (10(13/32)≤Side Space≤49(13/14))	Case 2 (Side Space ≥49(13/14))
4 sides are walls		A ≥ 10 (13/32) B ≥ 300 (11-13/16) C ≥ 10 (13/32) D ≥ 500 (19-11/16)	A ≥ 50 (1-31/32) B ≥ 100 (3-15/16) C ≥ 50 (1-31/32) D ≥ 500 (19-11/16)
		A ≥ 10 (13/32) B ≥ 300 (11-13/16) C ≥ 10 (13/32) D ≥ 500 (19-11/16) E ≥ 20 (25/32)	A ≥ 50 (1-31/32) B ≥ 100 (3-15/16) C ≥ 50 (1-31/32) D ≥ 500 (19-11/16) E ≥ 100 (3-15/16)
		A ≥ 10 (13/32) B ≥ 300 (11-13/16) C ≥ 10 (13/32) D ≥ 500 (19-11/16) E ≥ 20 (25/32) F ≥ 600 (23-5/8)	A ≥ 50 (1-31/32) B ≥ 100 (3-15/16) C ≥ 50 (1-31/32) D ≥ 500 (19-11/16) E ≥ 100 (3-15/16) F ≥ 500 (19-11/16)
		A ≥ 10 (13/32) B ≥ 300 (11-13/16) C ≥ 10 (13/32) D ≥ 300 (11-13/16) E ≥ 20 (25/32) F ≥ 500 (19-11/16)	A ≥ 50 (1-31/32) B ≥ 100 (3-15/16) C ≥ 50 (1-31/32) D ≥ 100 (3-15/16) E ≥ 100 (3-15/16) F ≥ 500 (19-11/16)
Rear to Rear		A ≥ 10 (13/32) B ≥ 500 (19-11/16) C ≥ 10 (13/32) D ≥ 500 (19-11/16) F ≥ 900 (35-7/16)	A ≥ 50 (1-31/32) B ≥ 500 (19-11/16) C ≥ 50 (1-31/32) D ≥ 500 (19-11/16) F ≥ 600 (23-5/8)
		A ≥ 10 (13/32) B ≥ 500 (19-11/16) C ≥ 10 (13/32) D ≥ 500 (19-11/16) E ≥ 20 (25/32) F ≥ 1 200 (47-1/4)	A ≥ 50 (1-31/32) B ≥ 500 (19-11/16) C ≥ 50 (1-31/32) D ≥ 500 (19-11/16) E ≥ 100 (3-15/16) F ≥ 900 (35-7/16)
		A ≥ 10 (13/32) B ≥ 500 (19-11/16) C ≥ 10 (13/32) D ≥ 500 (19-11/16) E ≥ 20 (25/32) F ≥ 1 800 (70-7/8)	A ≥ 50 (1-31/32) B ≥ 500 (19-11/16) C ≥ 50 (1-31/32) D ≥ 500 (19-11/16) E ≥ 100 (3-15/16) F ≥ 1 200 (47-1/4)
Only 2 sides are walls		A ≥ 10 (13/32) B ≥ 300 (11-13/16)	
		A ≥ 200 (7-7/8) B ≥ 300 (11-13/16) E ≥ 400 (15-3/4)	
Limitations on the height of the wall (Refer to 4 side walls)	<ul style="list-style-type: none"> The height of the wall on the front side must be 1500 mm (59 inch) or less. The height of the wall on the inlet side must be 500 mm (19-11/16 inch) or less. There is no limit to the wall on the side. If the height of the walls on the front and the side are higher than the limit, there must be additional space on the front and the side. <ul style="list-style-type: none"> - Additional Space on the front side by 1/2 of h1 - Additional Space on the inlet side by 1/2 of h2 - h1 = A(Actual height) - 1 500 mm (59 inch) - h2 = B(Actual height) - 500 mm (19-11/16 inch) 		

Seasonal wind and cautions in winter

- Sufficient measures are required in a snow areas or severe cold areas in winter so that product can be operated well.
- Get ready for seasonal wind or snow in winter even in other areas.
- Install a suction and discharge duct not to let in snow or rain.
- Install the outdoor unit In such a way that it should not come in contact with snow directly. If snow piles up and freezes on the air suction hole, the system may malfunction. If it is installed at snowy area, attach the hood to the system.
- The raised support platform must be high enough to allow the unit to remain above possible snow drifts, and must be higher than the maximum anticipated snowfall for the location.
- Where snow accumulated on the upper part of the Outdoor Unit by more than 10 cm (3.9 inch), always remove snow for operation.

- Don't install the suction hole and discharge hole of the Outdoor Unit facing the seasonal wind.

Remove the Rear Grille

- Remove the rear grille in snowy area.
- Make sure that heat exchanger should not be damaged.

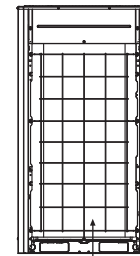

Rear Grille

LIFTING METHOD

- When carrying the suspended, unit pass the ropes under the unit and use the two suspension points each at the front and rear.
- Always lift the unit with ropes attached at four points so that impact is not applied to the unit.
- Attach the ropes to the unit at an angle of 40° or less.

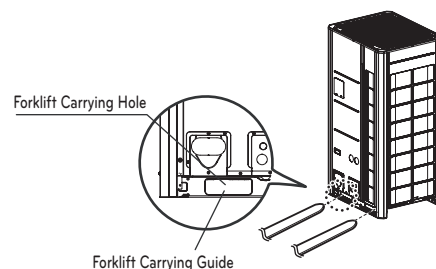
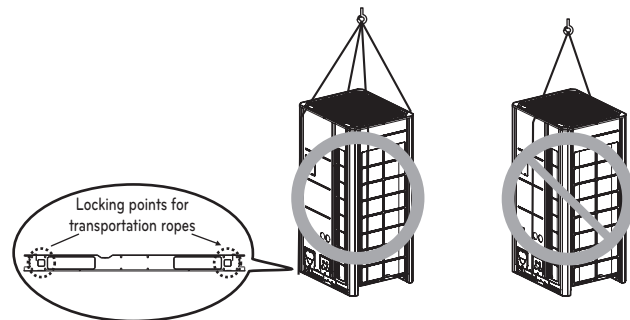

CAUTION

Be very careful while carrying the product.

- Do not have only one person carry product if it is more than 20 kg (44 lbs).
- PP bands are used to pack some products. Do not use them as a mean for transportation because they are dangerous.
- Do not touch heat exchanger fins with your bare hands. Otherwise you may get a cut in your hands.
- Tear plastic packaging bag and scrap it so that children cannot play with it. Otherwise plastic packaging bag may suffocate children to death.
- When carrying in Outdoor Unit, be sure to support it at four points. Carrying in and lifting with 3-point support may make Outdoor Unit unstable, resulting in a fall.
- Use 2 belts of at least 8 m (26.2 ft) long.
- Place extra cloth or boards in the locations where the casing comes in contact with the sling to prevent damage.
- Hoist the unit making sure it is being lifted at its center of gravity.

INSTALLATION

- Install at places where it can endure the weight and vibration/noise of the outdoor unit.
- The outdoor unit support blocks at the bottom shall have width of at least 100 mm (3-15/16 inch) under the Unit's legs before being fixed.
- The outdoor unit support blocks should have minimum height of 200 mm (7-7/8 inch).
- Anchor bolts must be inserted at least 75 mm (2-15/16 inch).

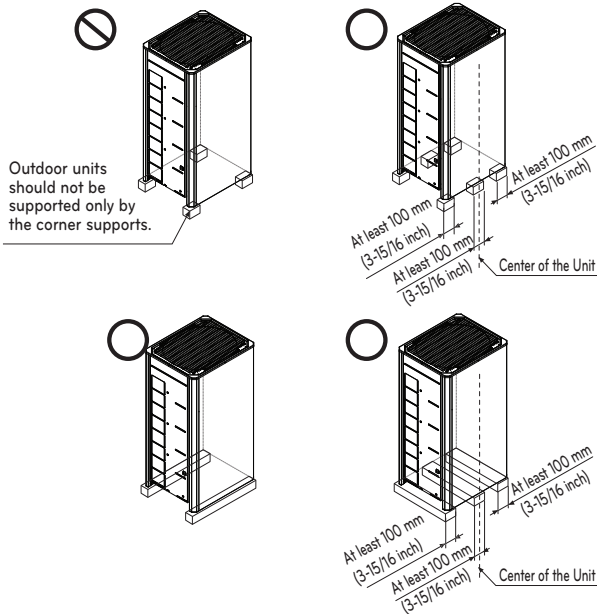

The location of the Anchor bolts

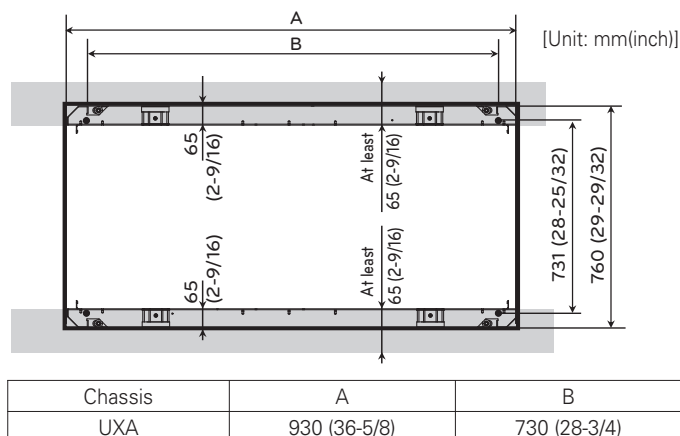

Foundation for Installation

- Fix the unit tightly with bolts as shown below so that unit will not fall down due to earthquake or gust.
- Use the H-beam support as a base support
- Noise and vibration may occur from the floor or wall since vibration is transferred through the installation part depending on installation status. Thus, use anti-vibration materials (cushion pad) fully (The base pad shall be more than 200 mm (7-7/8 inch)).

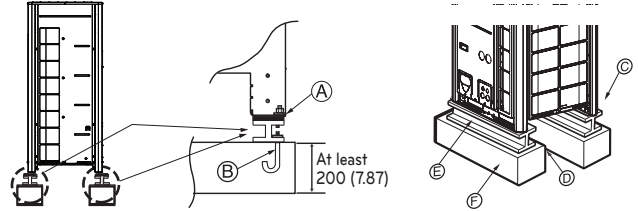

- (A) The corner part must be fixed firmly. Otherwise, the support for the installation may be bent.
- (B) Get and use M10 Anchor bolt.
- (C) Put Cushion Pad between the outdoor unit and ground support for the vibration protection in wide area.
- (D) Space for pipes and wiring (Pipes and wirings for bottom side)
- (E) H-beam support
- (F) Concrete support

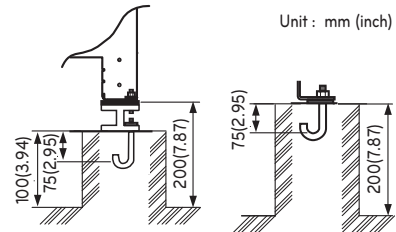

WARNING

- Install where it can sufficiently support the weight of the outdoor unit. If the support strength is not enough, the outdoor unit may drop and hurt people.
- Install where the outdoor unit may not fall in strong wind or earthquake. If there is a fault in the supporting conditions, the outdoor unit may fall and hurt people.
- Please take extra cautions on the supporting strength of the ground, water outlet treatment (treatment of the water flowing out of the outdoor unit in operation), and the passages of the pipe and wiring, when making the ground support.
- Do not use tube or pipe for water outlet in the Base panel. Use drainage instead for water outlet. The tube or pipe may freeze and the water may not be drained.

CAUTION

- Be sure to remove the Pallet (Wood Support) of the bottom side of the outdoor unit Base panel before fixing the bolt. It may cause the unstable state of the outdoor settlement, and may cause freezing of the heat exchanger resulting in abnormal operations.
- Be sure to remove the Pallet (Wood Support) of the bottom side of the outdoor unit before welding. Not removing Pallet (Wood Support) causes hazard of fire during welding.

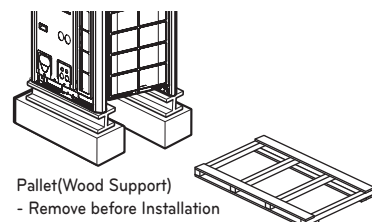

Preparation of Piping

Main cause of gas leakage is defect in flaring work. Carry out correct flaring work in the following procedure.

Cut the pipes and the cable

- Use the accessory piping kit or the pipes purchased locally.
- Measure the distance between the indoor and the outdoor unit.
- Cut the pipes a little longer than measured distance.
- Cut the cable 1.5 m (4.92 ft) longer than the pipe length.

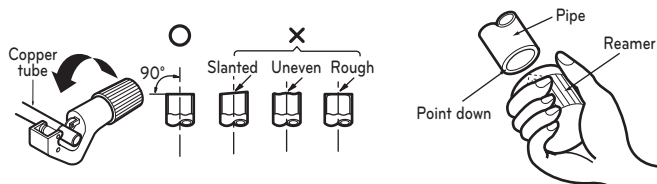

Burrs removal

- Completely remove all burrs from the cut cross section of pipe/tube.
- Put the end of the copper tube/pipe to downward direction as you remove burrs in order to avoid to let burrs drop in the tubing.

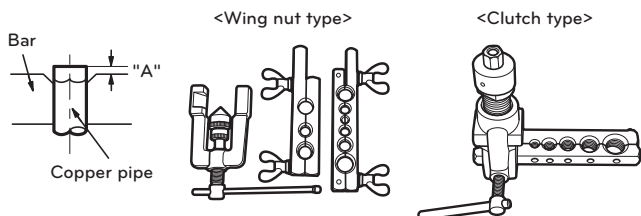

Flaring work

- Carry out flaring work using flaring tool as shown below.

Pipe diameter Inch (mm)	A inch (mm)	
	Wing nut type	Clutch type
Ø 1/4 (Ø 6.35)	0.04~0.05(1.1~1.3)	0~0.02 (0~0.5)
Ø 3/8 (Ø 9.52)	0.06~0.07(1.5~1.7)	
Ø 1/2 (Ø 12.7)	0.06~0.07(1.6~1.8)	
Ø 5/8 (Ø 15.88)	0.06~0.07(1.6~1.8)	
Ø 3/4 (Ø 19.05)	0.07~0.08(1.9~2.1)	

Firmly hold copper tube in a bar(or die) as indicated dimension in the table above.

Check

- Compare the flared work with figure below.
- If flare is noted to be defective, cut off the flared section and do flaring work again.

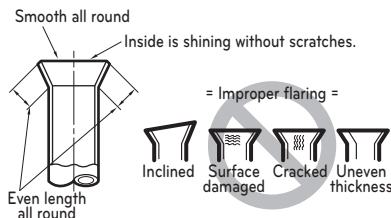

Flare shape and flare nut tightening torque

Precautions when connecting pipes

- See the following table for flare part machining dimensions.
- When connecting the flare nuts, apply refrigerant oil to the inside and outside of the flares and turn them three or four times at first. (Use ester oil or ether oil.)
- See the following table for tightening torque. (Applying too much torque may cause the flares to crack.)
- After all the piping has been connected, use nitrogen to perform a gas leak check.
- Only Annealed pipe should be used for flared joint.
- The outside diameter of pipe should be smaller than 20 mm.

Pipe size [mm (inch)]	Tightening Torque N·m (lbs·ft)	A [mm (inch)]	Flare shape
Ø 9.52 (3/8)	38±4 (28±3.0)	12.8 (0.5)~13.2 (0.52)	
Ø 12.7 (1/2)	55±6 (41±4.4)	16.2 (0.64)~16.6 (0.65)	
Ø 15.88 (5/8)	75±7 (55±5.2)	19.3 (0.76)~19.7 (0.78)	

CAUTION

- Always use a charge hose for service port connection.
- After tightening the cap, check that no refrigerant leaks are present.
- When loosening a flare nut, always use two wrenches in combination. When connecting the piping, always use a spanner and torque wrench in combination to tighten the flare nut.
- When connecting a flare nut, coat the flare (inner and outer faces) with oil for R32 and hand tighten the nut 3 to 4 turns as the initial tightening.

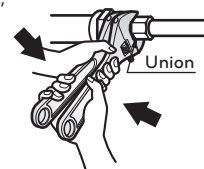

Opening shutoff valve

- 1 Remove the cap and turn the valve counter clockwise with the hexagon wrench.
- 2 Turn it until the shaft stops.
Do not apply excessive force to the shutoff valve. Doing so may break the valve body, as the valve is not a backseat type. Always use the special tool.
- 3 Make sure to tighten the cap securely.

Closing shutoff valve

- 1 Remove the cap and turn the valve clockwise with the hexagon wrench.
- 2 Securely tighten the valve until the shaft contacts the main body seal.
- 3 Make sure to tighten the cap securely.
* For the tightening torque, refer to the table on the below.

Tightening torque

Shut off valve size (mm (inch))	Tightening torque N·m (lbs·ft) (Turn clockwise to close)					
	Shaft (valve body)		Hexagonal wrench	Cap (Valve lid)	Service port	Flare nut
Closed	Opened					
Ø 6.35 (1/4)	6.0±0.6 (4.4±0.4)	4 mm (0.16 inch)	17.6±2.0 (13.0±1.5)	12.7±2 (9.4±1.5)	16±2 (12±1.5)	
Ø 9.52 (3/8)					38±4 (28±3.0)	
Ø 12.7 (1/2)	10.0±1.0 (7.4±0.7)	5 mm (0.24 inch)	20.0±2.0 (14.8±1.5)		55±6 (41±4.4)	
Ø 15.88 (5/8)	12.0±1.2 (8.9±0.9)		5.0±0.0 (3.7±0.4)		25.0±2.5 (18.4±1.8)	
Ø 19.05 (3/4)	14.0±1.4 (10.3±1.0)	8 mm (0.31 inch)			110±10 (81.1±7.4)	
Ø 22.2 (7/8)	30.0±3.0 (22.1±2.2)					
Ø 25.4 (1)					25±3 (18.5±2.2)	

Insulation of shutoff valve

- 1 Use the heat insulation material for the refrigerant piping which has an excellent heat-resistance (over 120 °C [248 °F]).
- 2 Precautions in high humidity circumstance:
This air conditioner has been tested according to the "ISO Conditions with Mist" and confirmed that there is not any default. However, if it is operated for a long time in high humid atmosphere (dew point temperature: More than 23 °C [73.4 °F]), water drops are liable to fall. In this case, add heat insulation material according to the following procedure:
 - Heat insulation material to be prepared: EPDM (Ethylene Propylene Diene Methylene)-over 120 °C [248 °F] the heat-resistance temperature.
 - Add the insulation over 10 mm [0.39 inch] thickness at high humidity environment.

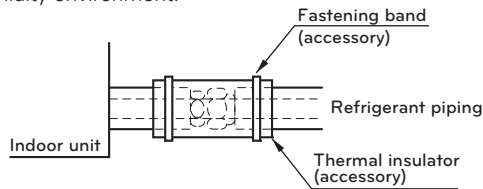

Plumbing materials and storage methods

Pipe must be able to obtain the specified thickness and should be used with low impurities.
Also when handling storage, pipe must be careful to prevent a fracture, deformity and wound.
Should not be mixed with contaminations such as dust, moisture.

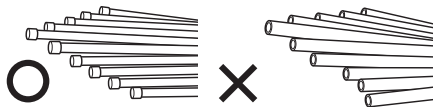

Refrigerant piping on three principles

	Drying	Cleanliness	Airtight
	Should be no moisture inside	No dust inside.	There is no refrigerant leakage
Items			
Cause failure	<ul style="list-style-type: none"> - Significant hydrolysis of refrigerant oil - Degradation of refrigerant oil - Poor insulation of the compressor - Do not cold and warm - Clogging of EEV, Capillary 	<ul style="list-style-type: none"> - Degradation of refrigerant oil - Poor insulation of the compressor - Do not cold and warm - Clogging of EEV, Capillary 	<ul style="list-style-type: none"> - Gas shortages - Degradation of refrigerant oil - Poor insulation of the compressor - Do not cold and warm
Countermeasure	<ul style="list-style-type: none"> - No moisture in the pipe - Until the connection is completed, the plumbing pipe entrance should be strictly controlled. - Stop plumbing at rainy day. - Pipe entrance should be taken side or bottom. - When removal burr after cutting pipe, pipe entrance should be taken down. - Pipe entrance should be fitted cap when pass through the walls. 	<ul style="list-style-type: none"> - No dust in the pipe. - Until the connection is completed, the plumbing pipe entrance should be strictly controlled. - Pipe entrance should be taken side or bottom. - When removal burr after cutting pipe, pipe entrance should be taken down. - Pipe entrance should be fitted cap when pass through the walls. 	<ul style="list-style-type: none"> - Airtightness test should be. - Brazing operations to comply with standards. - Flare to comply with standards. - Flange connections to comply with standards.

Nitrogen substitution method

Welding, as when heating without nitrogen substitution a large amount of the oxide film is formed on the internal piping.
The oxide film is a caused by clogging EEV, Capillary, oil hole of accumulator and suction hole of oil pump in compressor.
It prevents normal operation of the compressor.
In order to avoid this problem, Welding should be done after replacing air by nitrogen gas.
When welding plumbing pipe, the work is required.

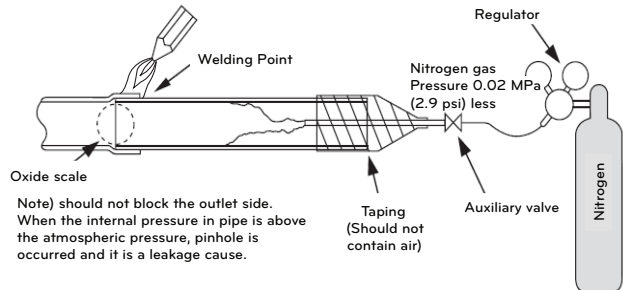

CAUTION

- Always use the nitrogen. (not use oxygen, carbon dioxide, and a Chevron gas)
Please use the following nitrogen pressure 0.02 MPa (2.9 psi)
 - **Oxygen:** Promotes oxidative degradation of refrigerant oil. Because it is flammable, it is strictly prohibited to use.
 - **Carbon dioxide:** Degrade the drying characteristics of gas
 - **Chevron Gas:** Toxic gas occurs when exposed to direct flame
- Always use a pressure reducing valve.
- Please do not use commercially available antioxidant. The residual material seems to be the oxide scale is observed. In fact, due to the organic acids generated by oxidation of the alcohol contained in the anti-oxidants, ants nest corrosion occurs. (Causes of organic acid → alcohol + copper + water + temperature)

REFRIGERANT PIPING INSTALLATION

For Heat Pump System Installation

Precautions on Pipe connection / Valve operation

Pipe connection is done by connecting from the end of the pipe to the branching pipes, and the refrigerant pipe coming out of the outdoor unit is divided at the end to connect to each indoor unit. Flare connection for the indoor unit, and welding connection for the outdoor pipe and the branching parts.

- Use hexagonal wrench to open/close the valve.

* In case of the heat pump system installation, be sure to maintain to close no use pipe like below picture.

* Refer to the accessory installation manual provided.

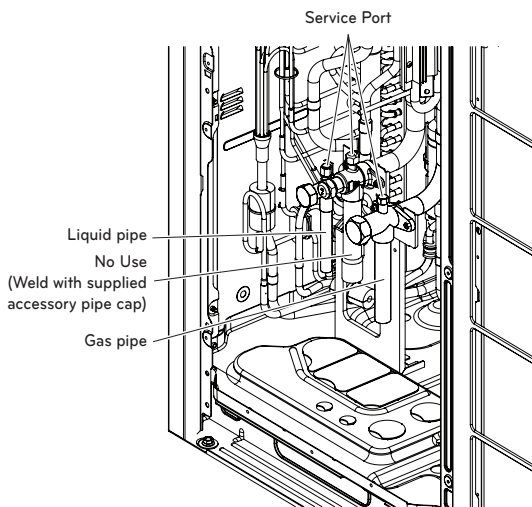

WARNING

- Always careful not to leak the refrigerant during welding.
- The refrigerant generates poisonous gas harmful to human body if combusted.
- Do not perform welding in a closed space.
- Be sure to close the cap of the service port to prevent gas leakage after the work.

CAUTION

Please block the pipe knock outs of the front and side panels after installing the pipes.
(Animals or foreign objects may be brought in to damage wires.)

Caution

- 1 Use the following materials for refrigerant piping.
 - Material: Seamless phosphorous deoxidized copper pipe
 - Wall thickness : Comply with the relevant local and national regulations for the designed pressure 3.8 MPa (551 psi). We recommend the following table as the minimum wall thickness.

Outer diameter [mm(inch)]	6.35 (1/4)	9.52 (3/8)	12.7 (1/2)	15.88 (5/8)	19.05 (3/4)	22.2 (7/8)	25.4 (1)
Minimum thickness [mm(inch)]	0.8 (0.03)	0.8 (0.03)	0.8 (0.03)	0.99 (0.04)	0.99 (0.04)	0.99 (0.04)	0.99 (0.04)
Outer diameter [mm(inch)]	28.58 (1-1/8)	31.8 (1-1/4)	34.9 (1-3/8)	38.1 (1-1/2)	41.3 (1-5/8)	44.45 (1-3/4)	53.98 (2-1/8)
Minimum thickness [mm(inch)]	0.99 (0.04)	1.1 (0.04)	1.21 (0.05)	1.35 (0.05)	1.43 (0.06)	1.55 (0.06)	2.1 (0.08)

- 2 Commercially available piping often contains dust and other materials. Always blow it clean with a dry inert gas.
- 3 Use care to prevent dust, water or other contaminants from entering the piping during installation.
- 4 Reduce the number of bending portions as much as possible, and make bending radius as big as possible.
- 5 Always use the branch piping set shown below, which are sold separately.

Y branch	Header		
	4 branches	7 branches	10 branches
ARBLB01621, ARBLB03321, ARBLB07121, ARBLB14521, ARBLB23220	ARBL054	ARBL057	ARBL1010
	ARBL104	ARBL107	ARBL2010

- 6 If the diameters of the branch piping of the designated refrigerant piping differs, use a pipe cutter to cut the connecting section and then use an adapter for connecting different diameters to connect the piping.
- 7 Always observe the restrictions on the refrigerant piping (such as rated length, difference in height, and piping diameter). Failure to do so can result in equipment failure or a decline in heating/cooling performance.
- 8 A second branch cannot be made after a header. (These are shown by ⊘.)

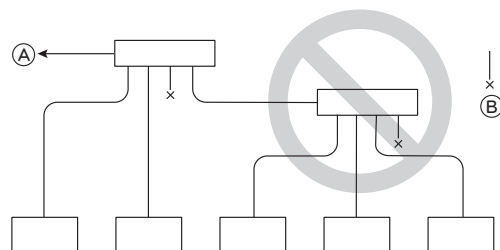
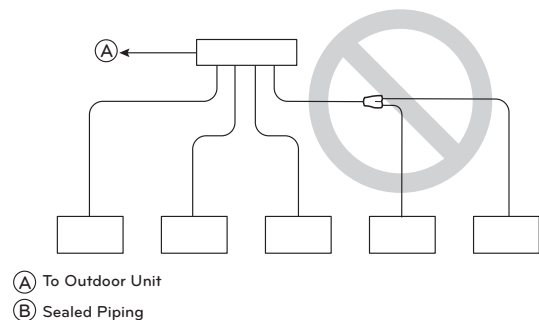

- 9 The Multi V will stop due to an abnormality like excessive or insufficient refrigerant. At such a time, always properly charge the unit. When servicing, always check the notes concerning both the piping length and the amount of additional refrigerant.
- 10 Never perform a pump down. This will not only damage the compressor but also deteriorate the performance.
- 11 Never use refrigerant to perform an air purge. Always evacuate air by using a vacuum pump.
- 12 Always insulate the piping properly. Insufficient insulation will result in a decline in heating/cooling performance, drip of condensate and other such problems.
- 13 When connecting the refrigerant piping, make sure the service valves of the Outdoor Unit is completely closed (the factory setting) and do not operate it until the refrigerant piping for the Outdoor and Indoor Units has been connected, a refrigerant leakage test has been performed and the evacuation process has been completed.
- 14 Always use a non-oxidizing brazing material for brazing the parts and do not use flux. If not, oxidized film can cause clogging or damage to the compressor unit and flux can harm the copper piping or refrigerant oil.

⚠ WARNING

When installing and moving the air conditioner to another site, be sure to make recharge refrigerant after perfect evacuation.

- If a different refrigerant or air is mixed with the original refrigerant, the refrigerant cycle may malfunction and the unit may be damaged.
- After selecting diameter of the refrigerant pipe to suit total capacity of the indoor unit connected after branching, use an appropriate branch pipe set according to the pipe diameter of the indoor unit and the installation pipe drawing.

For Heat Recovery System Installation

Precautions on Pipe connection / Valve operation

Pipe connection is done by connecting from the end of the pipe to the branching pipes, and the refrigerant pipe coming out of the outdoor unit is divided at the end to connect to each indoor unit. Flare connection for the indoor unit, and welding connection for the outdoor pipe and the branching parts.

- Use hexagonal wrench to open/close the valve.

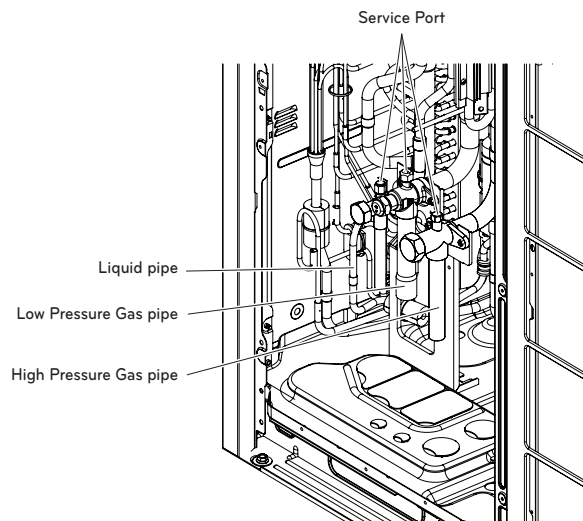

⚠ WARNING

- Always careful not to leak the refrigerant during welding.
- The refrigerant generates poisonous gas harmful to human body if combusted.
- Do not perform welding in a closed space.
- Be sure to close the cap of the service port to prevent gas leakage after the work.

⚠ CAUTION

Please block the pipe knock outs of the front and side panels after installing the pipes.
(Animals or foreign objects may be brought in to damage wires.)

Installation procedure for HR unit

- 1 Using an insert-hole-in- anchor, hang the hanging bolt.
- 2 Install a hexagon nut and a flat washer (locally-procured) to the hanging bolt as shown in the figure in the bottom, and fit the main unit to hang on the hanger metal.
- 3 After checking with a level that the unit is level, tighten the hexagon nut.
* The tilt of the unit should be within $\pm 5^\circ$ in front/back and left/right.
- 4 This unit should be installed suspended from ceiling and side A should always be facing up.
- 5 Insulate not used pipes completely as shown in the figure.

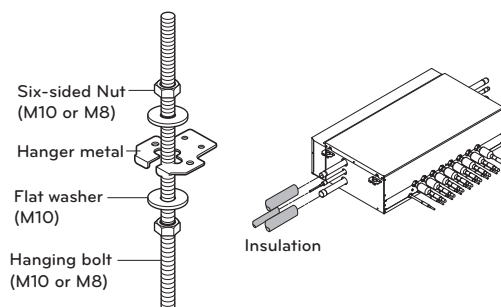

Installation of Outdoor Unit, HR Unit, Indoor Unit Refrigerant Pipe

3 pipes are connected to the HR unit from the outdoor unit, classified into liquid pipe, low pressure gas pipe and high pressure gas pipe depending on status of refrigerant passing through the pipe.

You must connect 3 pipes from outdoor unit to HR unit.

For connection between indoor unit and HR unit, you must connect both liquid pipe and gas pipe from the HR unit to the indoor unit. In this case, connect them to the indoor unit starting from No.1 connection port of the HR unit (the port number is displayed on ports of the HR unit). Use auxiliary flare as annexed parts in connection to the indoor unit.

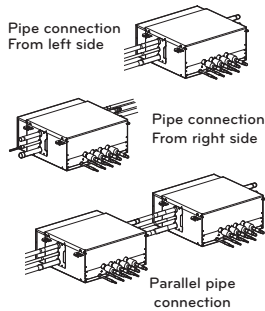
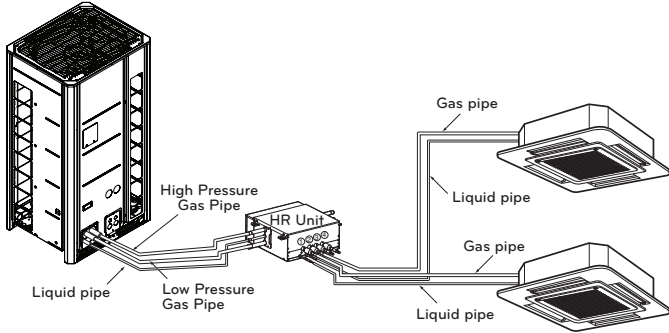

CAUTION

Whenever connecting the indoor units with the HR unit, install the indoor units in numerical order from No.1.

Ex) In case of installing 3 indoor units : No. 1, 2, 3 (O), No. 1, 2, 4 (X), No.1, 3, 4 (X), No.2, 3, 4 (X).

Type of HR Unit

Select an HR unit according to the number of the indoor units to be installed. HR units are classified into 5 types by the number of connectable indoor units.

PRHR023 (2 branches), PRHR033 (3 branches), PRHR043 (4 branches), PRHR063 (6 branches), PRHR083 (8 branches)

Joint Method of HR Unit (Big Duct : ARNU76GB8-, ARNU763B8-, ARNU96GB8-, ARNU963B8-)

Joint Method is required when the big duct chassis is installed. In Joint Method, two neighboring outlets of one HR unit are linked by Y branch pipe and connected to one indoor unit.

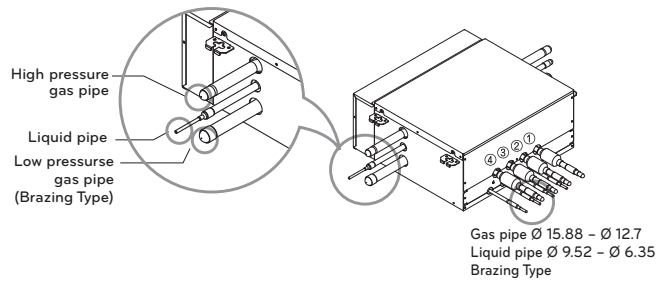
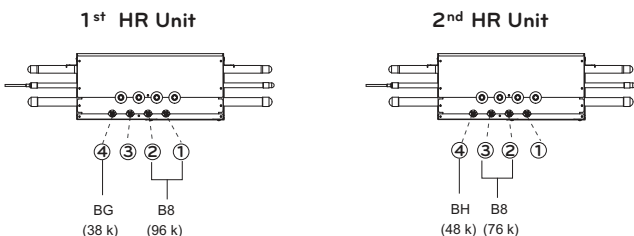

[Unit : mm (inch)]

HR unit	PRHR023	PRHR033	PRHR043 PRHR063 PRHR083
Low pressure gas pipe	\varnothing 22.2 (7/8)	\varnothing 28.58 (1-1/8)	\varnothing 28.58 (1-1/8)
High pressure gas pipe	\varnothing 19.05 (3/4)	\varnothing 22.2 (7/8)	\varnothing 22.2 (7/8)
Liquid pipe	\varnothing 9.52 (3/8)	\varnothing 12.7 (1/2)	\varnothing 15.88 (5/8)

Installation of Zoning Control

Some indoor unit can be connected to one port of HR unit.

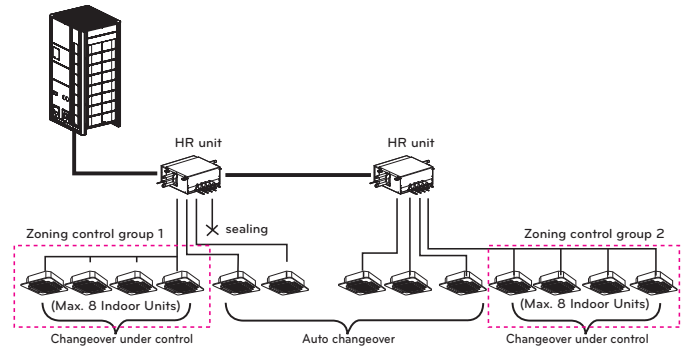

WARNING

- A branch pipe of HR unit allows up to 17.6 kW (60 kBTu/h) based on cooling capacity of the indoor unit. (up to 17.6 kW (60 kBTu/h) for max installation)
- The maximum total capacity of indoor units connected to a PRHR083 HR unit is 67.4 kW (230 kBTu/h).
- The maximum number of indoor units connected to a PRHR083 HR unit are 64 indoor units. (The Maximum indoor units per a branch pipe of HR unit are 8 indoor units)
- There is not operate "Auto-changeover" & "Mode override" function in the zoning group.
- When there are operating indoor units on cooling(heating) mode, another indoor units aren't changed on heating(cooling) mode in the zoning group.

[Reducers for HR unit]

[Unit : mm (inch)]

Type of HR unit	Liquid pipe	Gas pipe	
		High pressure	Low pressure
HR unit reducer	2 port	\varnothing 9.52(3/8) \varnothing 6.35(1/4)	\varnothing 19.05(3/4) \varnothing 15.88(5/8) \varnothing 12.7(1/2)
		\varnothing 12.7(1/2) \varnothing 9.52(3/8)	\varnothing 22.2(7/8) \varnothing 19.05(3/4) \varnothing 15.88(5/8)
	3 port	\varnothing 15.88(5/8) \varnothing 12.7(1/2) \varnothing 9.52(3/8)	\varnothing 22.2(7/8) \varnothing 19.05(3/4) \varnothing 15.88(5/8)
		\varnothing 12.7(1/2) \varnothing 9.52(3/8)	\varnothing 28.58(1-1/8) \varnothing 22.2(7/8) \varnothing 19.05(3/4)
	4 port	\varnothing 12.7(1/2) \varnothing 9.52(3/8)	\varnothing 15.88(5/8) \varnothing 12.7(1/2)
		\varnothing 12.7(1/2) \varnothing 9.52(3/8)	\varnothing 19.05(3/4) \varnothing 15.88(5/8)
6 port	\varnothing 12.7(1/2) \varnothing 9.52(3/8)	\varnothing 15.88(5/8) \varnothing 12.7(1/2)	
8 port	\varnothing 12.7(1/2) \varnothing 9.52(3/8)	\varnothing 19.05(3/4) \varnothing 15.88(5/8)	

Caution

- Use the following materials for refrigerant piping.
 - Material: Seamless phosphorous deoxidized copper pipe
 - Wall thickness : Comply with the relevant local and national regulations for the designed pressure 3.8 MPa (551 psi). We recommend the following table as the minimum wall thickness.

Outer diameter [mm(inch)]	6.35 (1/4)	9.52 (3/8)	12.7 (1/2)	15.88 (5/8)	19.05 (3/4)	22.2 (7/8)	25.4 (1)
Minimum thickness [mm(inch)]	0.8 (0.03)	0.8 (0.03)	0.8 (0.03)	0.99 (0.04)	0.99 (0.04)	0.99 (0.04)	0.99 (0.04)
Outer diameter [mm(inch)]	28.58 (1-1/8)	31.8 (1-1/4)	34.9 (1-3/8)	38.1 (1-1/2)	41.3 (1-5/8)	44.45 (1-3/4)	53.98 (2-1/8)
Minimum thickness [mm(inch)]	0.99 (0.04)	1.1 (0.04)	1.21 (0.05)	1.35 (0.05)	1.43 (0.06)	1.55 (0.06)	2.1 (0.08)

- Commercially available piping often contains dust and other materials. Always blow it clean with a dry inert gas.
- Use care to prevent dust, water or other contaminants from entering the piping during installation.
- Reduce the number of bending portions as much as possible, and make bending radius as big as possible.
- Always use the branch piping set shown below, which are sold separately.

Y branch	Header		
	4 branches	7 branches	10 branches
ARBLB01621, ARBLB03321, ARBLB07121, ARBLB14521, ARBLB23220	ARBL054	ARBL057	ARBL1010
	ARBL104	ARBL107	ARBL2010

- If the diameters of the branch piping of the designated refrigerant piping differs, use a pipe cutter to cut the connecting section and then use an adapter for connecting different diameters to connect the piping.
- Always observe the restrictions on the refrigerant piping (such as rated length, difference in height, and piping diameter). Failure to do so can result in equipment failure or a decline in heating/cooling performance.
- A second branch cannot be made after a header. (These are shown by ⊗.)

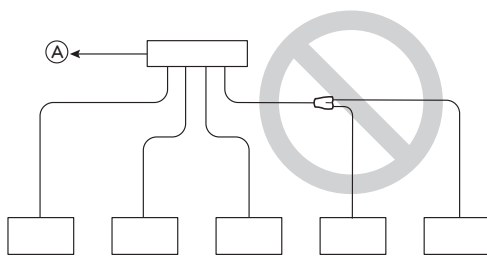

- (A) To Outdoor Unit
- (B) Sealed Piping

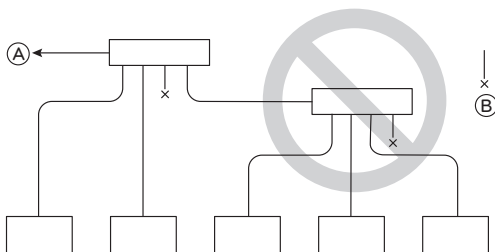

- The Multi V will stop due to an abnormality like excessive or insufficient refrigerant. At such a time, always properly charge the unit. When servicing, always check the notes concerning both the piping length and the amount of additional refrigerant.
- Never perform a pump down. This will not only damage the compressor but also deteriorate the performance.
- Never use refrigerant to perform an air purge. Always evacuate air by using a vacuum pump.
- Always insulate the piping properly. Insufficient insulation will result in a decline in heating/cooling performance, drip of condensate and other such problems.
- When connecting the refrigerant piping, make sure the service valves of the Outdoor Unit is completely closed (the factory setting) and do not operate it until the refrigerant piping for the Outdoor and Indoor Units has been connected, a refrigerant leakage test has been performed and the evacuation process has been completed.
- Always use a non-oxidizing brazing material for brazing the parts and do not use flux. If not, oxidized film can cause clogging or damage to the compressor unit and flux can harm the copper piping or refrigerant oil.

! WARNING

When installing and moving the air conditioner to another site, be sure to make recharge refrigerant after perfect evacuation.

- If a different refrigerant or air is mixed with the original refrigerant, the refrigerant cycle may malfunction and the unit may be damaged.
- After selecting diameter of the refrigerant pipe to suit total capacity of the indoor unit connected after branching, use an appropriate branch pipe set according to the pipe diameter of the indoor unit and the installation pipe drawing.

PIPE CONNECTIONS BETWEEN INDOOR AND OUTDOOR UNIT

- Pipe connections can be done on the front side or on the side according to the installation environments.
- Be sure to let 0.2 kgf/cm² (2.8 psi) Nitrogen flow in the pipe when welding.
- If Nitrogen was not flown during welding, many oxidized membranes may form inside the pipe and disturb the normal operations of valves and condensers.

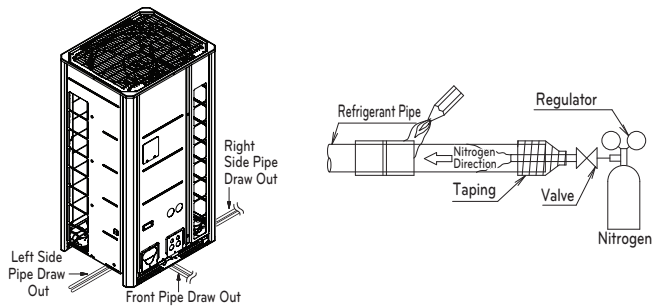

Remove leakage prevention cap

- Remove the leakage prevention cap attached to the outdoor unit service valve before pipe work.
- Proceed the leakage prevention cap removal as follows:
 - Verify whether all the pipes are locked.
 - Extract remaining refrigerant or air inside using the service port.
 - Remove the leakage prevention cap

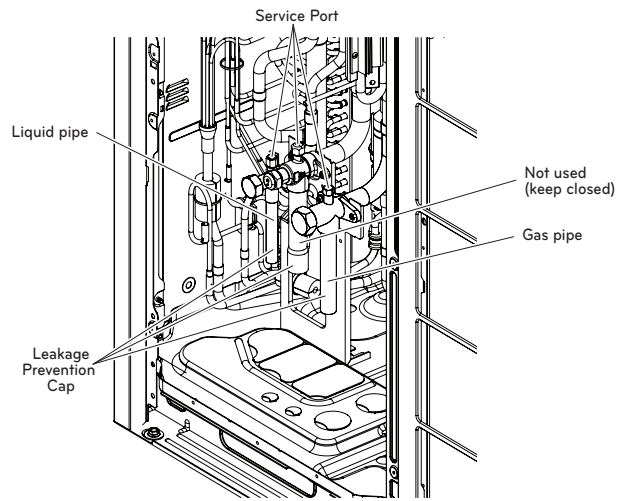

For Heat Pump System Installation

Preparation Work

- Use Knock Outs of Base Pan of the outdoor unit for Left/Right or Bottom pipe drawing outs.

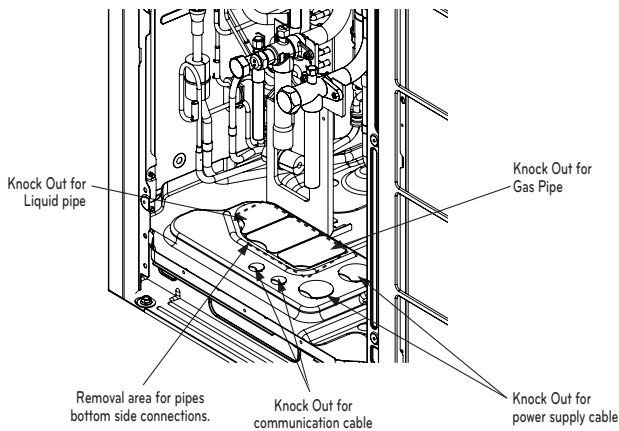

Pipe Drawing Out during Single / Series connection

Method of drawing out pipes on the front side

- Proceed with the pipe work as shown in the below figure for front side pipe drawing out.

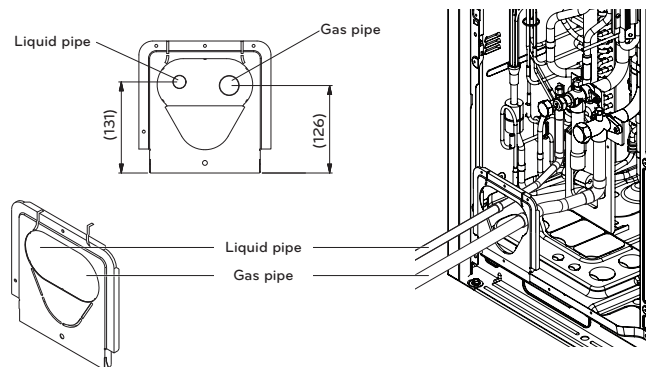

CAUTION

- Do not give damage to the pipe/base during the Knock Out work.
- Proceed to pipe work after removing burr after Knock Out work.
- Perform sleeve work to prevent damage to the wire when connecting wires using Knock Outs.

	Chassis	A	B	C
UXA				

Chassis	A(mm)	B(mm)	C(mm)
8HP	9.52(3/8)	-	19.05(3/4)
10HP	9.52(3/8)	-	19.05(3/4)
12HP	12.7(1/2)	-	22.2 (7/8)

* Elbow is Field supplied
 * Elbow size are same as Pipe 'A', 'C'.

Method of drawing out pipes on the bottom side

- Drawing out common pipe through side panel

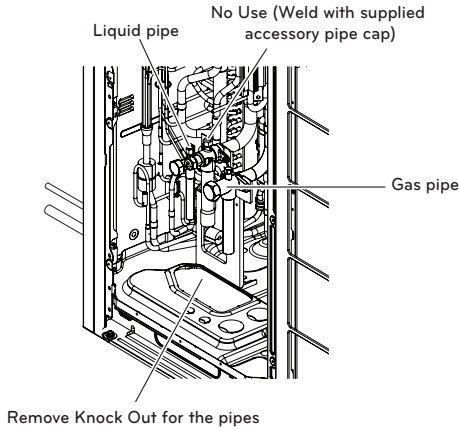

* Please weld with the proper Low pressure Gas pipe included with product.

For Heat Recovery System Installation

Preparation Work

- Use Knock Outs of Base Pan of the outdoor unit for Left/Right or Bottom pipe drawing outs.

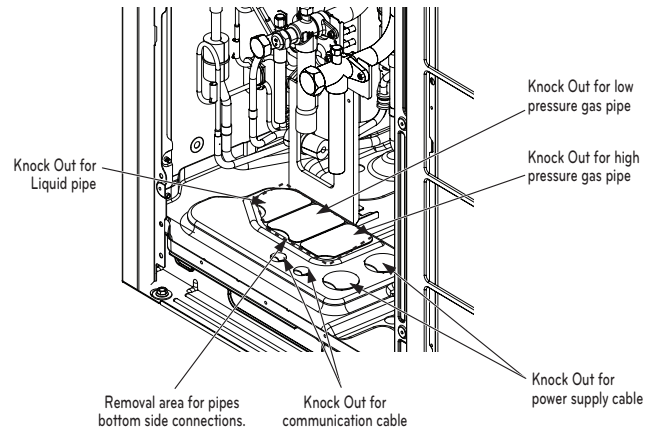

Refrigerant piping system

Y branch method

- Ⓐ : Outdoor Unit
- Ⓑ : 1st branch (Y branch)
- Ⓒ : Indoor Units

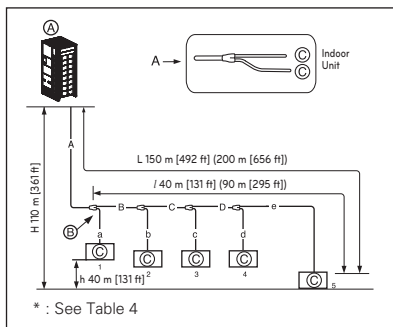

* : See Table 4

Combination of Y branch/header Method

- Ⓐ : Outdoor Unit
- Ⓑ : 1st branch (Y branch)
- Ⓒ : Y branch
- Ⓓ : Indoor Unit
- Ⓔ : Header
- Ⓕ : Sealed piping

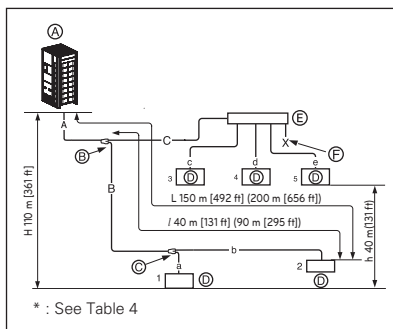

* : See Table 4

Header Method

- Ⓐ : Outdoor Unit
- Ⓒ : Indoor Units
- Ⓓ : Sealed piping
- Ⓔ : Header

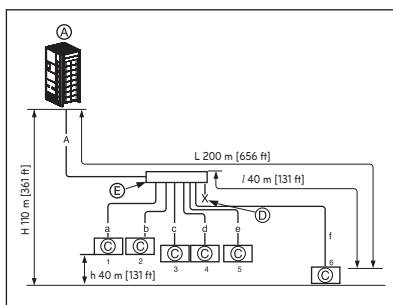

CAUTION

- Do not give damage to the pipe/base during the Knock Out work.
- Proceed to pipe work after removing burr after Knock Out work.
- Perform sleeve work to prevent damage to the wire when connecting wires using Knock Outs.

Remove leakage prevention cap

- Remove the leakage prevention cap attached to the outdoor unit service valve before pipe work.
- Proceed the leakage prevention cap removal as follows:
 - Verify whether the liquid/gas pipes are locked.
 - Extract remaining refrigerant or air inside using the service port.
 - Remove the leakage prevention cap

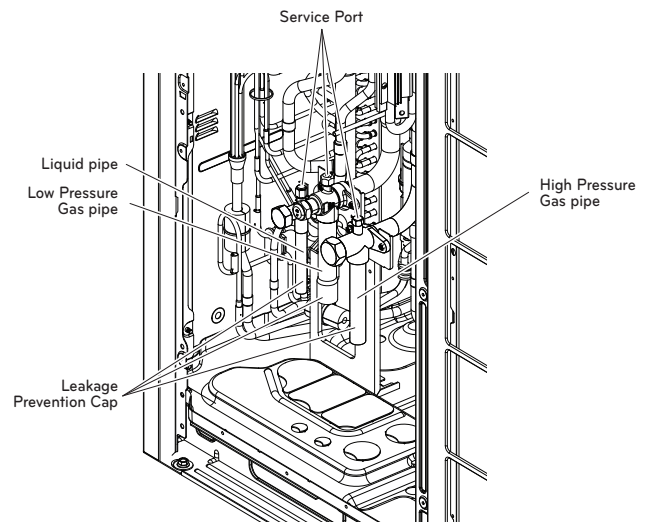

Pipe Drawing Out during Single / Series connection

Method of drawing out pipes on the front side

- Proceed with the pipe work as shown in the below figure for front side pipe drawing out.

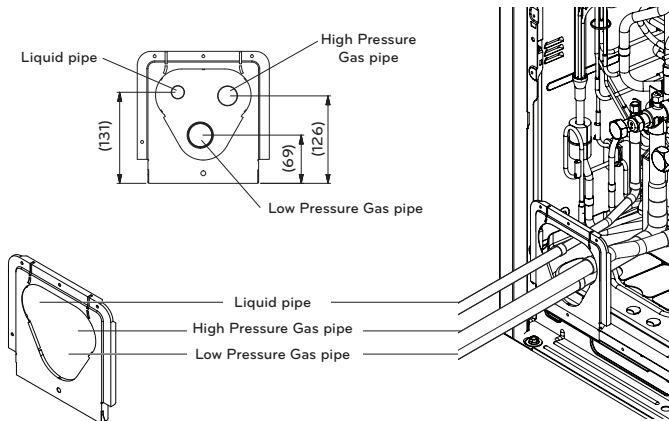

Chassis		A	B	C
UXA				
	8HP	9.52(3/8)	19.05(3/4)	15.88 (5/8)
	10HP	9.52(3/8)	19.05 (3/4)	15.88 (5/8)
	12HP	12.7(1/2)	22.2 (7/8)	19.05(3/4)

* Elbow is Field supplied
 * Elbow size are same as Pipe 'A', 'B', 'C'.

Method of drawing out pipes on the bottom side

- Drawing out common pipe through side panel

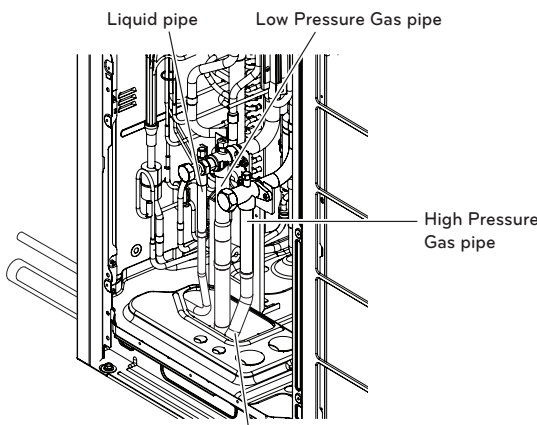

Remove Knock Out for the bottom side of Liquid / Gas pipe

Refrigerant piping system

Example : 12 Indoor Units connected

- Ⓐ : Outdoor Unit
- Ⓑ : Y branch
- Ⓓ : Indoor Unit
- Ⓔ : Connection branch pipe between Outdoor units : ARCNB41
- Ⓕ : Connection branch pipe between Outdoor units : ARCNB31
- Ⓖ : Connection branch pipe between Outdoor units : ARCNB21
- Ⓗ : Header
- Ⓘ : HR Unit

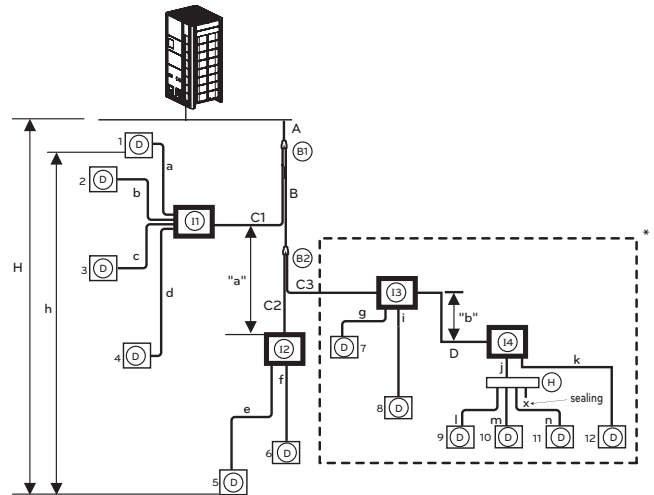

- Case 1 ("a") : Maximum height is 15 m (49.2 ft) if you install with Y branch.
- Case 2 ("b") : Maximum height is 5 m (16.4 ft) in serial connection of HR units.

(**) Conditional Application (In case of D12 is the farthest in door)

Below condition must be satisfied for 40~90 m (131~295 ft) piping length after first branch.

- 1 Diameter of pipes between first branch and the last branch should be increased by one step, except if the pipe diameter B, C3 is same as diameter A (main pipe diameter)
 $\varnothing 6.35 (1/4), \varnothing 9.52 (3/8), \varnothing 12.7 (1/2), \varnothing 15.88 (5/8), \varnothing 19.05 (3/4), \varnothing 22.2 (7/8), \varnothing 25.4^* (1), \varnothing 28.58 (1-1/8), \varnothing 31.8^* (1-1/4), \varnothing 34.9 (1-3/8), \varnothing 38.1^* (1-1/2)$
 * : If available on site, select this pipe size.
 Otherwise it doesn't need to be increased
- 2 While calculating total refrigerant piping length, pipe B, C3, D length should be calculated twice.
 $A + B \times 2 + C3 \times 2 + D \times 2 + C1 + C2 + a + b + c + d + e + f + g + i + j + k + l + m + n \leq 1000 \text{ m (3,281 ft)}$
- 3 Length of pipe from each indoor unit to the closest HR unit (a, b, c, d, e, f, g, i, j, k, l, m, n) $\leq 40 \text{ m (131 ft)}$
- 4 [Length of pipe from outdoor unit to the farthest indoor unit D12 (B+C3+D+K)] - [Length of pipe from outdoor unit to the closest indoor unit D1 (C1+a)] $\leq 40 \text{ m (131 ft)}$

Refrigerant pipe diameter from branch to branch (B,C,D)

! WARNING

- * : Serial connection of HR units : Capacity sum of indoor units ≤ 192.4 kBtu/hr
- Refer to the HR unit PCB part for the valve group control setting.
- It is recommended that difference in pipe lengths between an HR unit and indoor units, for example difference in length of a, b, c, and d, be minimized. The larger difference in pipe lengths, the more different performance between indoor units.
- Piping length from outdoor branch to outdoor unit ≤ 10 m (33 ft), equivalent length : max 13 m (43 ft)
- * If the large capacity indoor units (Over 5 HP; using over Ø 15.88 (5/8) / Ø 9.52 (3/8)), are installed, it should be used the Valve Group setting

Refrigerant pipe diameter from branch to branch (B,C)

Downward indoor unit total capacity [kW(Btu/h)]	Liquid pipe [mm(inch)]	Gas pipe [mm(inch)]	
		Low pressure	High pressure
≤ 5.6(19 100)	Ø 6.35(1/4)	Ø 12.7(1/2)	Ø 9.52(3/8)
< 16.0 (54 600)	Ø 9.52(3/8)	Ø 15.88(5/8)	Ø 12.7(1/2)
< 22.4 (76 400)	Ø 9.52(3/8)	Ø 19.05(3/4)	Ø 15.88(5/8)
< 33.6(114 700)	Ø 9.52(3/8)	Ø 22.2(7/8)	Ø 19.05(3/4)
< 50.4(172 000)	Ø 12.7(1/2)	Ø 28.58(1-1/8)	Ø 22.2(7/8)
< 67.2(229 400)	Ø 15.88(5/8)	Ø 28.58(1-1/8)	Ø 22.2(7/8)

Total pipe length = A + B + C1 + C2 + C3 + D + a + b + c + d + e + f + g + i + j + k + l + m + n ≤ 1,000 m (3,280 ft)

L	Longest pipe length	* Equivalent pipe length
	A+B+C3+D+k ≤ 150 m (200 m**) [(492 ft)(656 ft**)]	A+B+C3+D+k ≤ 175 m (225 m**) [(574 ft)(738 ft**)]
I	Longest pipe length after 1st branch	
	B+C3+D+k ≤ 40 m(90 m**) [131 ft (295 ft)]	
H	Difference in height(Outdoor Unit ↔ Indoor Unit)	
	H ≤ 110 m (361 ft)	
h	Difference in height (Indoor Unit ↔ Indoor Unit)	
	h ≤ 40 m (131 ft)	
h1	Difference in height (Outdoor Unit ↔ Outdoor Unit)	
	h1 ≤ 5 m (16.4 ft)	
"a", "b"	Difference in height(HR unit ↔ HR unit)	
	a ≤ 15 m (49 ft), b ≤ 5 m (16 ft)	

- * : Assume equivalent pipe length of Y branch to be 0.5 m (1.64 ft), that of header to be 1 m (3.3 ft), calculation purpose
- It is recommended that indoor unit is installed at lower position than the header.
- ** : To apply conditional application.

! WARNING

When the equivalent length between a outdoor and the farthest indoor unit is 90 m (295 ft) or more, main pipe(A) must be increased one grade.

Refrigerant pipe diameter from outdoor unit to first branch. (A)

ODU. Capacity (HP)	Standard Pipe Diameter			Pipe diameter when pipe length is ≥ 90 m (295 ft) or when height differential (ODU↔IDU) is > 50 m (164 ft)		
	Liquid Pipe mm (inch)	Low pressure gas pipe mm (inch)	High pressure gas pipe mm (inch)	Liquid Pipe mm (inch)	Low pressure gas pipe mm (inch)	High pressure gas pipe mm (inch)
8	Ø 9.52 (3/8)	Ø 19.05 (3/4)	Ø 15.88 (5/8)	Ø 12.7 (1/2)	Not increased	Not increased
10	Ø 9.52 (3/8)	Ø 19.05(3/4)	Ø 15.88(5/8)	Ø 12.7 (1/2)	Not increased	Not increased
12	Ø 12.7 (1/2)	Ø 22.2(7/8)	Ø 19.05(3/4)	Ø 15.88 (5/8)	Not increased	Not increased

Y branch, Header and HR unit connection pattern

Pattern 1

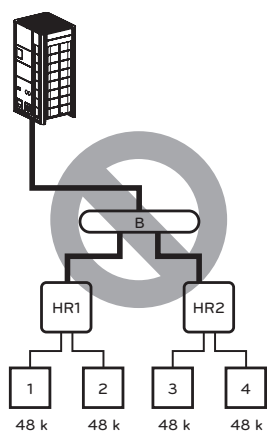

- Impossible installation : Head branch pipe → HR unit

Pattern 2

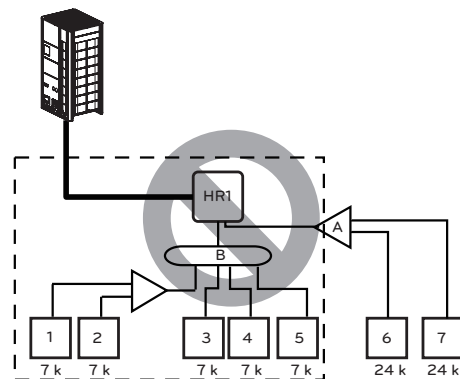

- Impossible installation : HR unit → Head branch pipe → Y and Head branch pipe.

Pattern 3

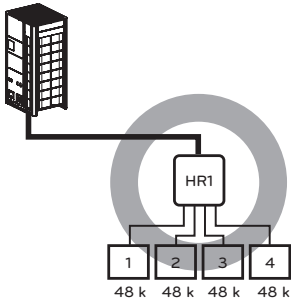

- The maximum total capacity of indoor units is 56.4 kW (192 kBtu/h).

Pattern 7

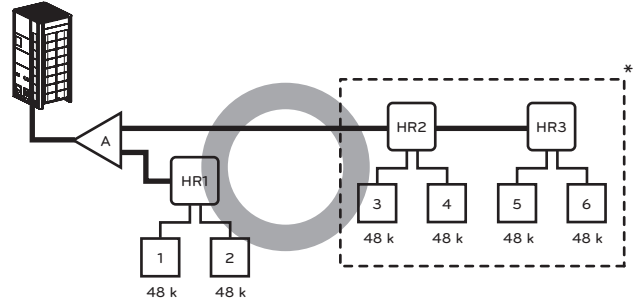

- * : Serial connection of HR units :
Capacity sum of indoor units ≤ 56.4 kW (192 kBtu/h)

Pattern 4

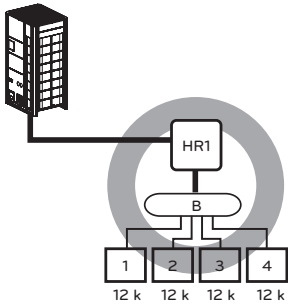

- The maximum total capacity of a branch pipe of HR unit is 14.1 kW (48 kBtu/h).

Pattern 8

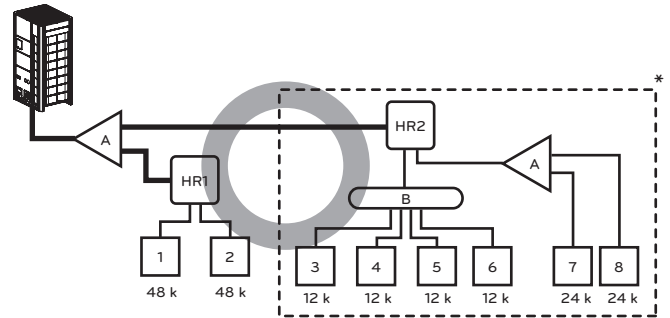

- * : Maximum indoor units per a branch are 8 indoor units

Pattern 5

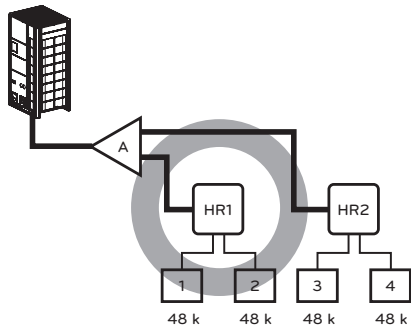

Indoor Unit	Y Branch pipe	Head Branch pipe

Outdoor Unit Low pressure Gas pipe High pressure Gas pipe Liquid pipe HR1 Gas pipe Liquid pipe Indoor Unit

- Pipe installation from outdoor units to HR units
——— : 3 pipes (Low pressure Gas pipe, High pressure Gas pipe, Liquid pipe)
- Pipe installation from HR units to indoor units
——— : 2 pipes (Gas pipe, Liquid pipe)

Keep the 40 m (131 ft) distance from the first branch to the farthest indoor.

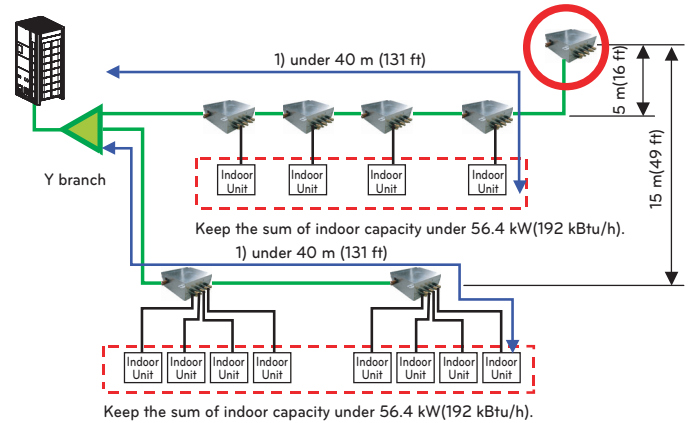

Pattern 6

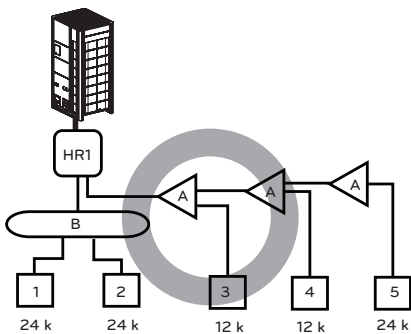

For Heat Pump And Heat Recovery System Installation

Pipe Connection Method between outdoor unit/indoor unit

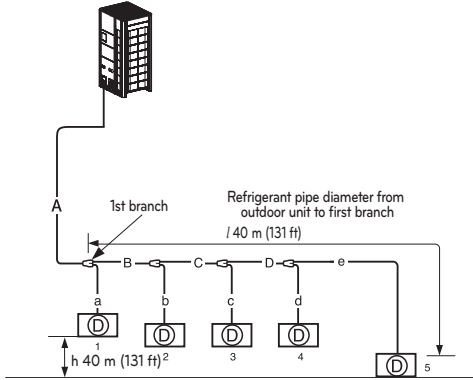

* See Table 2

A : Refrigerant pipe diameter from outdoor unit to first branch

(Table 1) Limit Pipe length

			Y branch Method	Combination of Y branch/header Method	Header Method
Max pipe length	Outdoor Unit ↔ Indoor Unit	Longest pipe length(L)	A+B+C+D+e ≤ 150 m [492 ft] (200 m [656 ft] : Conditional application)*	A+B+b ≤ 150 m [492 ft] A+C+e ≤ 150 m [492 ft] (200 m [656 ft] : Conditional application)*	A+f ≤ 200 m [656 ft]
		Equivalent pipe length	175 m [574 ft] (225 m [738 ft] : Conditional application)*	175 m [574 ft] (225 m [738 ft] : Conditional application)*	225 m [738 ft]
		Total pipe length	1 000 m [3 281 ft]	1 000 m [3 281 ft]	1 000 m [3 281 ft]
Max difference in height	Outdoor Unit ↔ Indoor Unit	Difference in height(H)	110 m [361 ft]	110 m [361 ft]	110 m [361 ft]
	Indoor Unit ↔ Indoor Unit	Difference in height(h)	40 m [131 ft]	40 m [131 ft]	40 m [131 ft]
Longest pipe length after 1st branch		Pipe length(l)	40 m [131 ft] (90 m [295 ft] : Conditional application)*	40 m [131 ft] (90 m [295 ft] : Conditional application)*	40 m [131 ft]

* See Table 4

! WARNING

Increased Pipe Diameter(table 2)

- When pipe length is 90 m [295 ft] or more from ODU to 1st branch
- When level difference is 50 m [164 ft] or more

(Table 2) Refrigerant pipe diameter from outdoor unit to first branch. (A)

ODU capacity (HP)	Pipe diameter when pipe length is < 90 m (295 ft) (Standard)		Pipe diameter when pipe length is ≥ 90 m (295 ft)		Pipe diameter when height differential (ODU↔IDU) is > 50 m (164 ft)	
	Liquid Pipe mm (inch)	Gas Pipe mm (inch)	Liquid Pipe mm (inch)	Gas Pipe mm (inch)	Liquid Pipe mm (inch)	Gas Pipe mm (inch)
8	Ø 9.52 (3/8)	Ø 19.05 (3/4)	Ø 12.7 (1/2)	Ø 22.2 (7/8)	Ø 12.7 (1/2)	Not increased
10	Ø 9.52 (3/8)	Ø 19.05(3/4)	Ø 12.7 (1/2)	Ø 22.2(7/8) *	Ø 12.7 (1/2)	Not increased
12	Ø 12.7 (1/2)	Ø 22.2(7/8)	Ø 15.88 (5/8)	Ø 25.4(1)	Ø 15.88 (5/8)	Not increased

* If available on site, select pipe size according to upper table. Otherwise it doesn't need to be increased.

(Table 3) Refrigerant pipe diameter from first branch to last branch (B,C,D)

Downward indoor unit total capacity [kW(Btu/h)]	Liquid pipe [mm(inch)]	Gas pipe [mm(inch)]
≤ 5.6(19 100)	Ø 6.35(1/4)	Ø 12.7(1/2)
< 16.0 (54 600)	Ø 9.52(3/8)	Ø 15.88(5/8)
≤ 22.4 (76 400)	Ø 9.52(3/8)	Ø 19.05(3/4)
< 33.6 (114 700)	Ø 9.52(3/8)	Ø 22.2(7/8)
< 50.4 (172 000)	Ø 12.7(1/2)	Ø 28.58(1-1/8)
< 67.2 (229 400)	Ø 15.88(5/8)	Ø 28.58(1-1/8)

(Table 4) Conditional Application

• To satisfy below condition to make 40 m ~ 90 m of pipe length after first branch.

Condition	Example
1 Diameter of pipes between first branch and the last branch should be increased by one step, except pipe diameter B,C,D is same as Diameter A	40 m [131 ft] < B+C+D+e 90 m [295 ft] → B, C, D Change a diameter Ø 6.35(1/4) → Ø 9.52(3/8), Ø 9.52(3/8) → Ø 12.7(1/2), Ø 12.7(1/2) → Ø 15.88(5/8), Ø 15.88(5/8) → Ø 19.05(3/4), Ø 19.05(3/4) → Ø 22.2(7/8), Ø 22.2(7/8) → Ø 25.4(1), Ø 25.4(1) → Ø 28.58(1-1/8), Ø 28.58(1-1/8) → Ø 31.8(1-1/4), Ø 31.8(1-1/4) → Ø 34.9(1-3/8), Ø 34.9(1-3/8) → Ø 38.1(1-1/2)
2 While calculating whole refrigerant pipe length, pipe B,C,D length should be calculated twice.	A+Bx2+Cx2+Dx2 +a+b+c+d+e ≤ 1 000 m [3 281 ft]
3 Length of pipe from each indoor unit to the closest branch	a,b,c,d,e ≤ 40 m [131 ft]
4 Length of pipe from outdoor unit to the farthest indoor unit 5 (A+B+C+D+e) - [Length of pipe outdoor unit to the closest indoor unit 1 (A+a)] ≤ 40 m [131 ft]	(A+B+C+D+e) - (A+a) ≤ 40 m [131 ft]

! WARNING

- In case of pipe diameter B connected after first branch is bigger than the main pipe diameter A, B should be of the same size with A.
- Ex) In case indoor unit combination ratio 120 % is connected to 24 HP(67.2 kW) outdoor unit.
 - 1) Outdoor unit main pipe diameter A : Ø 34.9(1-3/8)(Gas pipe), Ø 15.88(5/8)(liquid pipe)
 - 2) Pipe diameter B after first branch according to 120 % indoor unit combination(80.6kW) : Ø 34.9(1-3/8)(gas pipe), Ø 19.05(3/4)(liquid pipe)
 Therefore, pipe diameter B connected after first branch would be Ø 34.9(1-3/8)(gas pipe) / Ø 15.88(5/8)(liquid pipe) which is same with main pipe diameter.

Outdoor unit Connection

! WARNING

- In case of pipe diameter B connected after first branch is bigger than the main pipe diameter A, B should be of the same size with A.
- Ex) In case indoor unit combination ratio 120 % is connected to 70 kW outdoor unit.
 - 1) Outdoor unit main pipe diameter A : \varnothing 34.9(1-3/8)(Low pressure gas pipe), \varnothing 15.88(5/8)(liquid pipe), \varnothing 28.58(1-1/8)(High Pressure liquid pipe)
 - 2) Pipe diameter B after first branch according to 120 % indoor unit combination(84 kW) : \varnothing 34.9(1-3/8)(Low pressure gas pipe), \varnothing 19.05(3/4)(liquid pipe), \varnothing 28.58(1-1/8)(High Pressure liquid pipe)
 Therefore, pipe diameter B connected after first branch would be \varnothing 34.9(1-3/8)(Low pressure gas pipe), \varnothing 15.88(5/8)(liquid pipe), \varnothing 28.58(1-1/8)(High Pressure liquid pipe) which is same with main pipe diameter.

[Example]

Do not choose the main pipe diameter by downward indoor unit total capacity but its outdoor unit model name.
 Do not let the connection pipe from branch to branch exceed the main pipe diameter chosen by outdoor unit model name.
 EX) Where connecting the indoor units to the 22 HP (61.5 kW) outdoor unit to 120 % of its system capacity (73.8 kW) and branching 7 k (2.1 kW) indoor unit at the 1st branch
 Main pipe diameter(22 HP outdoor unit): \varnothing 28.58(1-1/8)(Low pressure gas pipe), \varnothing 15.88(5/8)(Liquid pipe), \varnothing 22.2(7/8)(High pressure gas pipe)
 Pipe diameter between 1st and 2nd branch (71.7 kW indoor units): \varnothing 34.9(1-3/8)(Gas pipe) \varnothing 19.05(3/4)(Liquid pipe) in conformity with Downward indoor units.
 Since the main pipe diameter of 22 HP outdoor unit is \varnothing 28.58(1-1/8)(Low pressure gas pipe), \varnothing 15.88(5/8)(Liquid pipe), \varnothing 22.2(7/8)(High pressure gas pipe) is used as the main pipe and the connection pipe between 1st and 2nd branch.

Indoor Unit Connection

Indoor Unit connecting pipe from branch (a,b,c,d,e,f)

Indoor Unit capacity [kW(Btu/h)]	Liquid pipe [mm(inch)]	Gas pipe [mm(inch)]
\leq 5.6(19 100)	\varnothing 6.35(1/4)	\varnothing 12.7(1/2)
$<$ 16.0(54 600)	\varnothing 9.52(3/8)	\varnothing 15.88(5/8)
$<$ 22.4(76 400)	\varnothing 9.52(3/8)	\varnothing 19.05(3/4)
$<$ 28.0(95 900)	\varnothing 9.52(3/8)	\varnothing 22.2(7/8)

! CAUTION

- Bending radius should be at least twice the diameter of the pipe.
- Bend pipe after 500 mm [19.7 inch] or more from branch(or header). Do not bend U type. It may affect performance or result in noise. If U type bending is required the R should be more than 200 mm [7.9 inch]

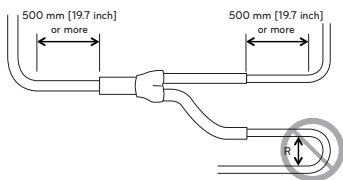

Branch pipe Fitting

Y branch

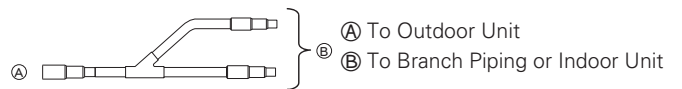

- Ensure that the branch pipes are attached horizontally or vertically (see the diagram below.)

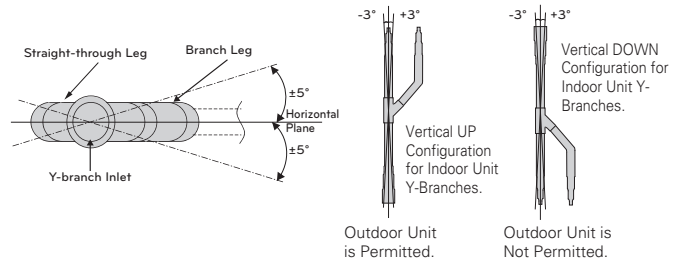

Outdoor unit Y-branches can only be installed in a horizontal or vertical UP configuration. The vertical DOWN configuration is not permitted. Fail to follow above procedures, there is a risk of product failure.

- There is no limitation on the joint mounting configuration.
- If the diameter of the refrigerant piping selected by the procedures described is different from the size of the joint, the connecting section should be cut with a pipe cutter.
- Branch pipe should be insulated with the insulator in each kit.

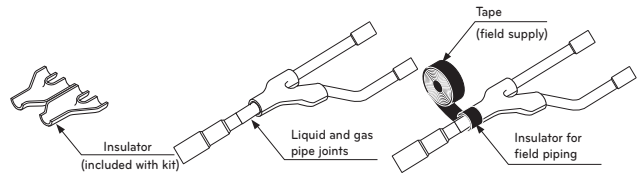

Header

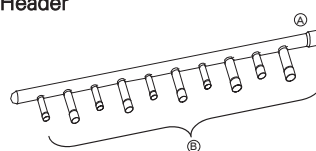

- The indoor unit having larger capacity must be installed closer to A than smaller one.
- If the diameter of the refrigerant piping selected by the procedures described is different from the size of the joint, the connecting section should be cut with a pipe cutter.

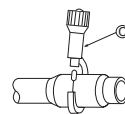

- © Pipe cutter
- When the number of pipes to be connected is smaller than the number of header branches, install a cap to the unconnected branches.

- When the number of indoor units to be connected to the branch pipes is less than the number of branch pipes available for connection then cap pipes should be fitted to the surplus branches.

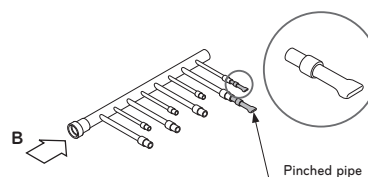

- Fit branch pipe lie in a horizontal plane.

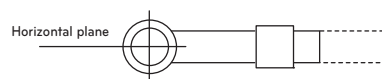

View from point B in the direction of the arrow

Distribution Method

Horizontal Distribution

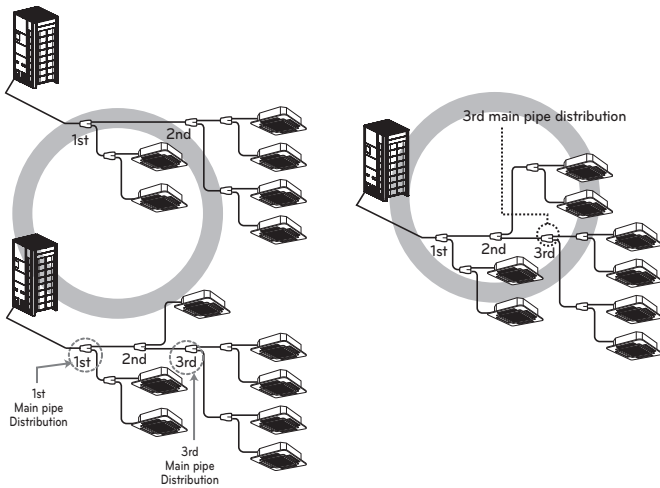

Vertical Distribution

- Ensure that the branch pipes are attached vertically.

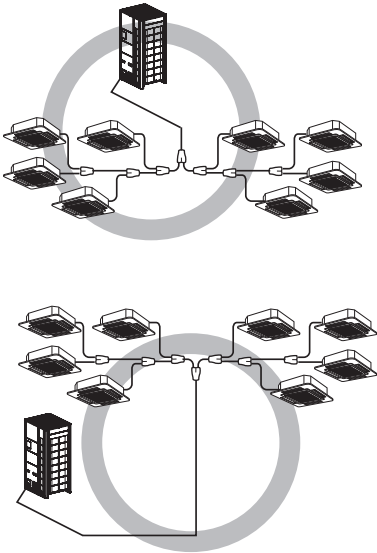

The others

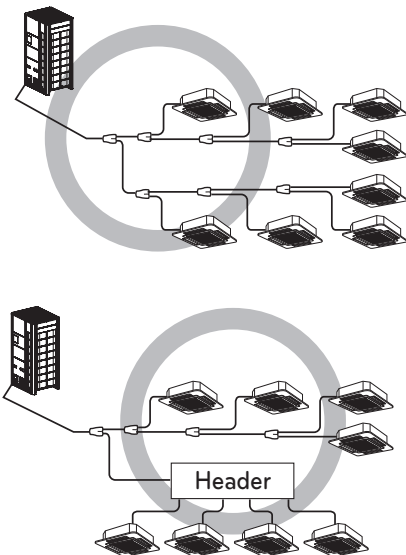

Vacuum Mode

This function is used for creating vacuum in the system after compressor replacement, ODU parts replacement or IDU addition/replacement.

Vacuum mode setting method

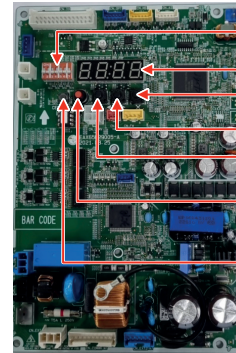
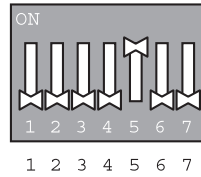

- DIP-SW01
- 7-Segment
- SW04C (X : cancel)
- SW03C (▶: forward)
- SW02C (◀: backward)
- SW01C (●: Confirm / Automatic Addressing)
- SW01D (reset)

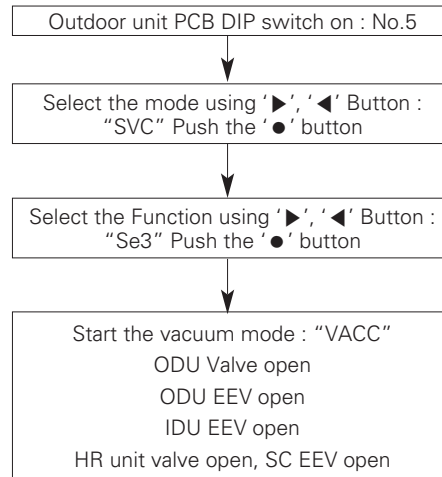

Vacuum mode off method

DIP switch off and push the reset button on Outdoor unit PCB

CAUTION

ODU operation stops during vacuum mode. Compressor can't operate.

Leak Test and Vacuum drying

Leak test

Leak test should be made by pressurizing nitrogen gas to 3.8 MPa(38.7 kgf/cm²). If the pressure does not drop for 24 hours, the system passes the test. If the pressure drops, check where the nitrogen leaks. For the test method, refer to the following figure. (Make a test with the service valves closed. Be also sure to pressurize liquid pipe, gas pipe and high pressure gas pipe)

The test result can be judged good if the pressure has not be reduced after leaving for about one day after completion of nitrogen gas pressurization.

Heat Pump

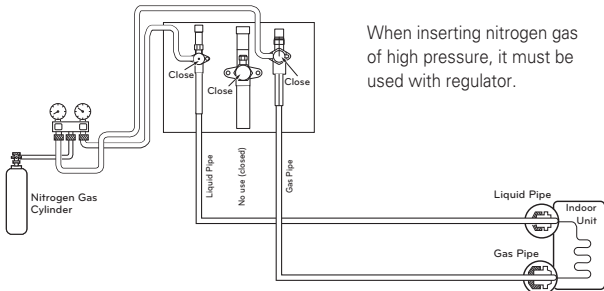

Heat Recovery

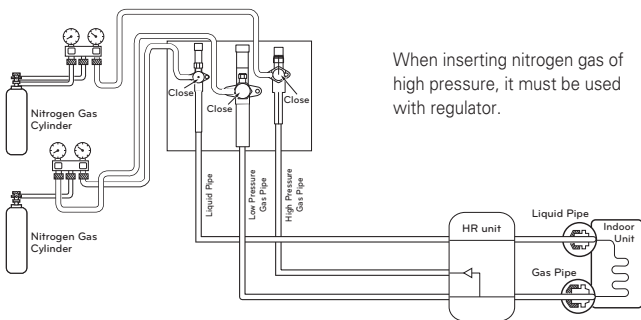

WARNING

Use a vacuum pump or Inert(nitrogen) gas when doing leakage test or air purge. Do not compress air or Oxygen and do not use Flammable gases. Otherwise, it may cause fire or explosion.

- There is the risk of death, injury, fire or explosion.

NOTE

If the ambient temperature differs between the time when pressure is applied and when the pressure drop is checked, apply the following correction factor

There is a pressure change of approximately 0.01 MPa(1.5 psi) for each 33.8 °F (1 °C) of temperature difference.

Correction= (Temp. at the time of pressurization – Temp. at the time of check) X 0.1

For example: Temperature at the time of pressurization 3.8 MPa(551 psi) is 80.6 °F (27 °C) 24 hour later: 3.73 MPa(541psi), 68 °F (20 °C) In this case the pressure drop of 0.07 MPa (10 psi) is because of temperature drop And hence there is no leakage in pipe occurred.

CAUTION

To prevent the nitrogen from entering the refrigeration system in the liquid state, the top of the cylinder must be at higher position than the bottom when you pressurize the system.

Usually the cylinder is used in a vertical standing position.

Vacuum

Vacuum drying should be made from the service port provided on the outdoor unit's service valve to the vacuum pump commonly used for liquid pipe, gas pipe and high/low pressure common pipe. (Make Vacuum from liquid pipe, gas pipe and high/low pressure common pipe with the service valve closed.)

* Never perform air purging using refrigerant.

- Vacuum drying: Use a vacuum pump that can evacuate to -100.7 kPa (-14.6 psi, 5 Torr, -755 mmHg).
 - Evacuate the system from the liquid and gas pipes with a vacuum pump for over 2 hrs and bring the system to -100.7 kPa(-14.6 psi). After maintaining system under that condition for over 1 hr, confirm the vacuum gauge rises. The system may contain moisture or leak.
 - Following should be executed if there is a possibility of moisture remaining inside the pipe. (Rainwater may enter the pipe during work in the rainy season or over a long period of time)
 - After evacuating the system for 2 hrs, give pressure to the system to 0.05 MPa(7.3 psi) (vacuum break) with nitrogen gas and then evacuate it again with the vacuum pump for 1hr to -100.7 kPa(-14.6 psi)(vacuum drying). If the system cannot be evacuated to -100.7 kPa(-14.6 psi) within 2 hrs, repeat the steps of vacuum break and its drying. Finally, check if the vacuum gauge does not rise or not, after maintaining the system in vacuum for 1 hr.

Heat Pump

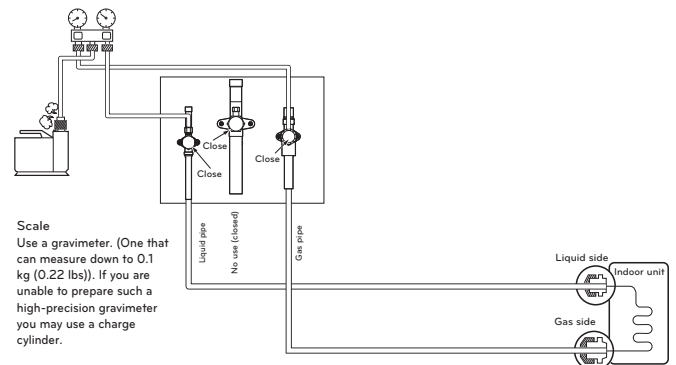

Heat Recovery

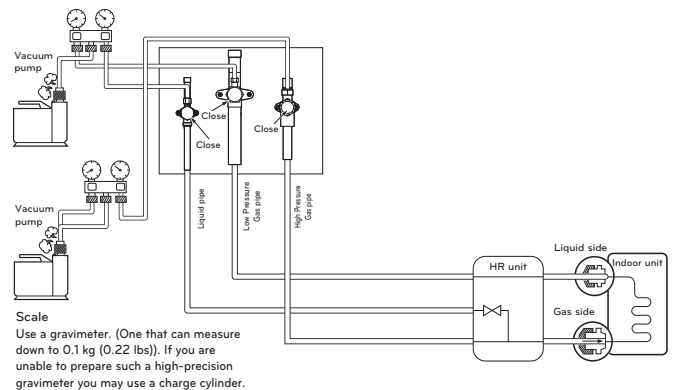

WARNING

Use a vacuum pump or Inert(nitrogen) gas when doing leakage test or air purge. Do not compress air or Oxygen and do not use Flammable gases. Otherwise, it may cause fire or explosion.

- There is the risk of death, injury, fire or explosion.

NOTE

Always add an appropriate amount of refrigerant. (For the refrigerant additional charge) Too much or too little refrigerant will cause trouble. To use the Vacuum Mode (If the Vacuum mode is set, all valves of Indoor units and Outdoor units will be opened.)

WARNING

When installing and moving the air conditioner to another site, recharge after perfect evacuation.

- If a different refrigerant or air is mixed with the original refrigerant, the refrigerant cycle may malfunction and the unit may be damaged.

Refrigerant charging

For Heat Pump System Installation

- Ⓐ Manifold Gauge
- Ⓑ Low Pressure Side Handle
- Ⓒ High Pressure Side Handle

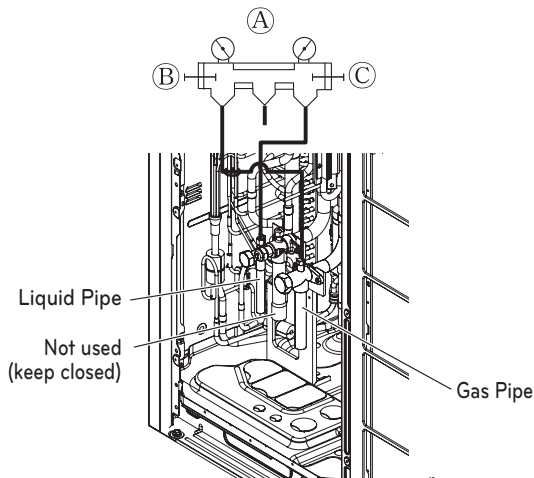

For Heat Recovery System Installation

- Ⓐ Manifold Gauge
- Ⓑ Low pressure side Handle
- Ⓒ High pressure side Handle

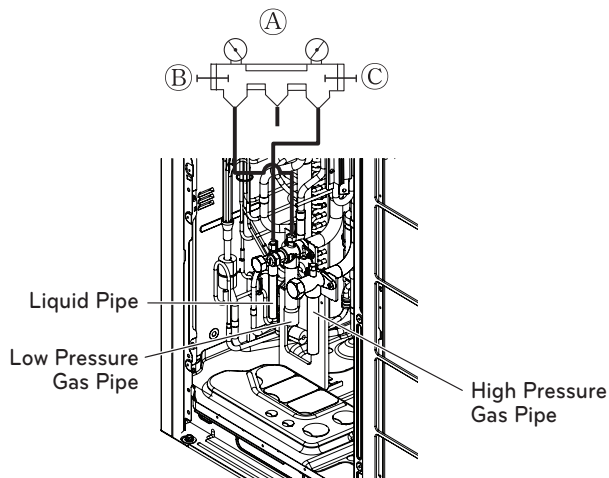

The amount of Refrigerant

The calculation of the additional charge should take into account the length of pipe and CF (correction Factor) value of indoor unit.

Additional charge(kg)	=	Total liquid pipe : Ø 25.4 mm	× 0.422 (kg/m)
	+	Total liquid pipe : Ø 22.2 mm	× 0.313 (kg/m)
	+	Total liquid pipe : Ø 19.05 mm	× 0.235 (kg/m)
	+	Total liquid pipe : Ø 15.88 mm	× 0.153 (kg/m)
	+	Total liquid pipe : Ø 12.7 mm	× 0.103 (kg/m)
	+	Total liquid pipe : Ø 9.52 mm	× 0.053 (kg/m)
	+	Total liquid pipe : Ø 6.35 mm	× 0.019 (kg/m)
	+	Number of installed HR units (2,3,4 port)	× 0.45 (kg)
	+	Number of installed HR units (6,8 port)	× 0.9 (kg)
	+	CF value of indoor unit	

Amount refrigerant of Indoor units

Example) 4 Way Ceiling Cassette 14.5 kW - 1ea,
Ceiling concealed Duct 7.3 kW - 2 ea,
Wall Mounted 2.3 kW - 4ea
CF = $0.41 \times 1 + 0.3 \times 2 + 0.2 \times 4 = 1.81$ kg

Attach the additional refrigerant table of IDU.

⚠ WARNING

- Pipe to be vacuumed : gas pipe, liquid pipe
(In case of Heat Recovery system, pipe to be vacuumed : High pressure gas pipe, Low pressure gas pipe, Liquid pipe)
- If the refrigerant amount is not exact, it may not operate properly.
- If additionally bottled refrigerant amount is over 10 %, condenser burst or insufficient indoor unit performance may be caused.

Thermal insulation of refrigerant piping

Be sure to give insulation work to refrigerant piping by covering liquid pipe and gas pipe separately with enough thickness heat-resistant polyethylene, so that no gap is observed in the joint between indoor unit and insulating material, and insulating materials themselves. When insulation work is insufficient, there is a possibility of condensation drip, etc. Pay special attention to insulation work to ceiling plenum.



Heat insulation material	Adhesive + Heat - resistant polyethylene foam + Adhesive tape	
Outer covering	Indoor	Vinyl tape
	Floor exposed	Water-proof hemp cloth + Bronze asphalt
	Outdoor	Water-proof hemp cloth + Zinc plate + Oily paint

- Ⓐ Heat insulation material
- Ⓑ Pipe
- Ⓒ Outer covering(Wind the connection part and cutting part of heat insulation material with a finishing tape.)

NOTE

When using polyethylene cover as covering material, asphalt roofing shall not be required.

Bad example

- Do not insulate gas or low pressure pipe and liquid or high pressure pipe together.

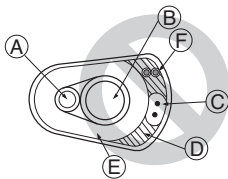

- Ⓐ Liquid pipe
- Ⓑ Gas pipe
- Ⓒ Power lines
- Ⓓ Finishing tape
- Ⓔ Insulating material
- Ⓕ Communication lines

- Be sure to fully insulate connecting portion.

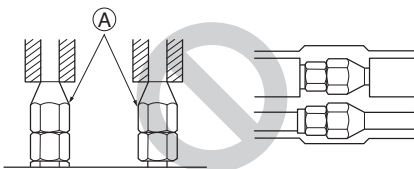

Ⓐ These parts are not insulated.

Good example

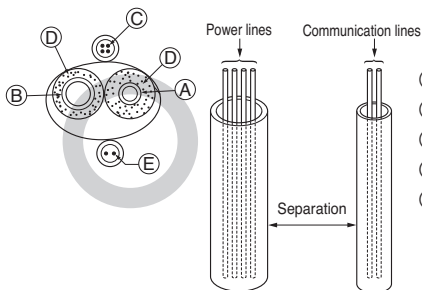

- Ⓐ Liquid pipe
- Ⓑ Gas pipe
- Ⓒ Power lines
- Ⓓ Insulating material
- Ⓔ Communication lines

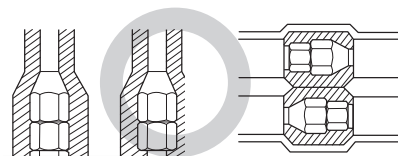

Penetrations

Inner wall (concealed)

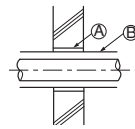

Outer wall

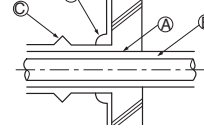

Outer wall (exposed)

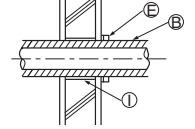

Floor (fireproofing)

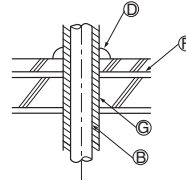

Roof pipe shaft

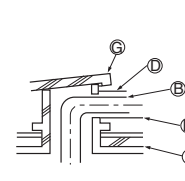

Penetrating portion on fire limit and boundary wall

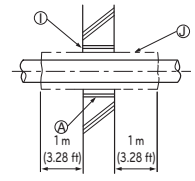

- Ⓐ Sleeve
- Ⓑ Heat insulating material
- Ⓒ Lagging
- Ⓓ Caulking material
- Ⓔ Band
- Ⓕ Waterproofing layer
- Ⓖ Sleeve with edge
- Ⓗ Lagging material
- Ⓙ Mortar or other incombustible caulking
- Ⓚ Incombustible heat insulation material

When filling a gap with mortar, cover the penetration part with steel plate so that the insulation material will not be caved in. For this part, use incombustible materials for both insulation and covering. (Vinyl covering should not be used.)

ELECTRICAL WIRING

Caution

- Follow ordinance of your governmental organization for technical standard related to electrical equipment, wiring regulations and guidance of each electric power company.

WARNING

Be sure to have authorized electrical engineers do the electric work using special circuits in accordance with regulations and this installation manual.
If power supply circuit has a lack of capacity or electric work deficiency, it may cause an electric shock or fire.

- Install the Outdoor Unit communication cable away from the power source wiring so that it is not affected by electric noise from the power source. (Do not run it through the same conduit.)
- Be sure to provide designated grounding work to Outdoor Unit.
- The installation of a residual current device(RCD) having a rated residual operating current not exceeding 30 mA is advisable.

CAUTION

Be sure to correct the outdoor unit to earth. Do not connect ground wire to any gas pipe, liquid pipe, lightning rod or telephone earth line. If earth is incomplete, it may cause an electric shock.

- Give some allowance to wiring for electrical part box of Indoor and Outdoor Units, because the box is sometimes removed at the time of service work.
- Never connect the main power source to terminal block of communication cable. If connected, electrical parts will be burnt out.
- Use the 2-core shielded wires for communication cable. (○ mark in the figure below)
If communication cable of different systems are wired with the same multiple core cable, the resultant poor transmitting and receiving will cause erroneous operations. (⊗ mark in the figure below)
- Only the communication cable specified should be connected to the terminal block for Outdoor Unit communication.

2-core shielded cables

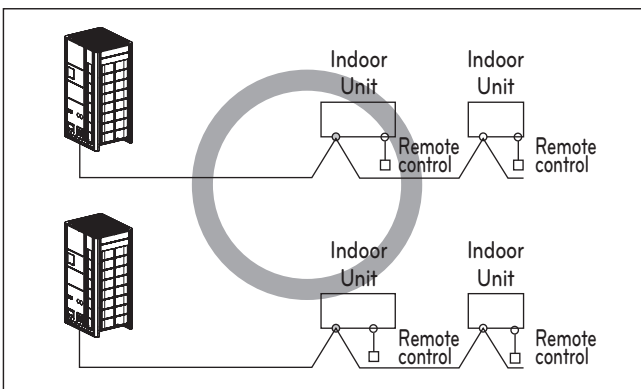

Multi-Core Cable

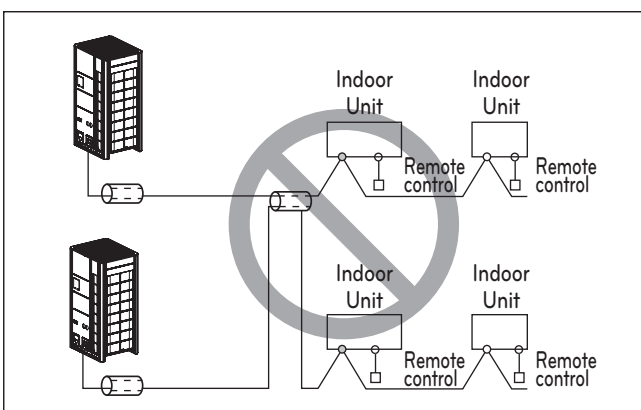

CAUTION

- Use the 2-core shielded wires for communication cables. Never use them together with power cables.
- The conductive shielding layer of cable should be grounded to the metal part of both units.
- Never use multi-core cable
- As this unit is equipped with an inverter, to install a phase leading capacitor not only will deteriorate power factor improvement effect, but also may cause capacitor abnormal heating. Therefore, never install a phase leading capacitor.
- Make sure that the power unbalance ratio is not greater than 2%. If it is greater the units lifespan will be reduced.

Precautions when laying power wiring

Use round pressure terminals for connections to the power terminal block.

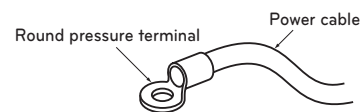

When none are available, follow the instructions below.

- Do not connect wiring of different thicknesses to the power terminal block. (Slack in the power wiring may cause abnormal heat.)
- When connecting cable which is the same thickness, do as shown in the figure below.

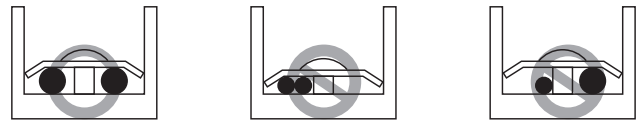

- For wiring, use the designated power cable and connect firmly, then secure to prevent outside pressure being exerted on the terminal block.
- Use an appropriate screwdriver for tightening the terminal screws. A screwdriver with a small head will strip the head and make proper tightening impossible.
- Over-tightening the terminal screws may break them.

CAUTION

When the 400 volt power supply is applied to "N" phase by mistake, check damaged parts in control box and replace them.

Control box and connecting position of wiring

- Remove all of the screws at front panel and remove the panel by pulling it forward.
- Connect communication cables between outdoor unit and indoor units through the terminal block.
- When the central control system is connected to the outdoor unit, a dedicated PCB must be connected between them.
- When connecting communication cable between outdoor unit and indoor units with shielded cable, connect the shield ground to the earth screw.



Front Panel

WARNING

The temperature sensor for outdoor air should not be exposed to direct sunlight.
- Provide an appropriate cover to intercept direct sunlight.

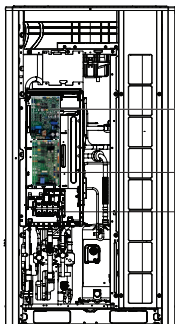

Main Board

External Board

Main power line terminal block
(Take care of the phase sequence of 3-phases 4-wires power system)

Communication and Power Cables

Communication cable

- Types : shielded wires
- Cross section : 1.0 ~ 1.5 mm² (1.55 × 10⁻³ ~ 2.32 × 10⁻³ in²)
- Maximum allowable temperature: 60 °C (140 °F)
- Maximum allowable cable length: under 1 000 m (3 281 ft)

Remote control cable

- Types : 3-core cables

Central control cable

Product type	Cable type	Diameter
ACP & AC Manager	2-core wires (shielded)	1.0 ~ 1.5 mm ² (1.55 × 10 ⁻³ ~ 2.32 × 10 ⁻³ in ²)
AC Smart	2-core wires (shielded)	1.0 ~ 1.5 mm ² (1.55 × 10 ⁻³ ~ 2.32 × 10 ⁻³ in ²)
Simple central controller	4-core wires (shielded)	1.0 ~ 1.5 mm ² (1.55 × 10 ⁻³ ~ 2.32 × 10 ⁻³ in ²)
AC Ez	4-core wires (shielded)	1.0 ~ 1.5 mm ² (1.55 × 10 ⁻³ ~ 2.32 × 10 ⁻³ in ²)

CAUTION

In case of using the shielded wires, it should be grounded.

Separation of communication and power cables

- If communication and power cables are installed alongside each other then there is a strong likelihood of operational faults developing due to interference in the signal wiring caused by electrostatic and electromagnetic coupling.

The tables below indicates our recommendation as to appropriate spacing of communication and power cables where these are to be run side by side

Current capacity of power cable		Spacing
100 V or more	10 A	300 mm (11-13/16 inch)
	50 A	500 mm (19-11/16 inch)
	100 A	1 000 mm (39-3/8 inch)
	Exceed 100 A	1 500 mm (59-1/16 inch)

NOTE

- The figures are based on assumed length of parallel cabling up to 100 m [328 ft]. For length in excess of 100 m [328 ft] the figures will have to be recalculated in direct proportion to the additional length of cable involved.
- If the power supply waveform continues to exhibit some distortion the recommended spacing in the table should be increased.
 - If the cable are laid inside conduits then the following point must also be taken into account when grouping various cable together for introduction into the conduits
 - Power cable(including power supply to air conditioner) and communication cables must not be laid inside the same
 - In the same way, when grouping the power wires and communication cables should not be bunched together.

CAUTION

If apparatus is not properly earthed then there is always a risk of electric shock, the grounding of the apparatus must be carried out by a qualified person.

Wiring of main power supply and equipment capacity

- Use a separate power supply for the Outdoor Unit and Indoor Unit.
- Bear in mind ambient conditions (ambient temperature, direct sunlight, rain water, etc.) when proceeding with the wiring and connections.
- The cable size is the minimum value for metal conduit wiring. The power cord size should be 1 rank thicker taking into account the line voltage drops. Make sure the power-supply voltage does not drop more than 10 %.
- Specific wiring requirements should adhere to the wiring regulations of the region.
- Power supply cords of parts of appliances for outdoor use should not be lighter than polychloroprene sheathed flexible cord.
- Don't install an individual switch or electrical outlet to disconnect each of indoor unit separately from the power supply.

The thickness of Minimum wire (mm ² [inch ²])			Leakage circuit breaker (4P ELCB)
Main power wire	Branch wire	Ground wire	
2.5~16 [3.875×10^{-3} ~ 2.48×10^{-2}]	-	2.5~4 [3.875×10^{-3} ~ 6.2×10^{-3}]	Below 20~60 A 100 mA 0.1 sec

* The above standard is CV wire standard.

* Please use the 3-phases 4-wires quadrupole Leakage circuit breaker of circuit breaker.

! WARNING

- Follow ordinance of your governmental organization for technical standard related to electrical equipment, wiring regulations and guidance of each electric power company.
- Make sure to use specified cables for connections so that no external force is imparted to terminal connections. If connections are not fixed firmly, it may cause heating or fire.
- Make sure to use the appropriate type of over current protection switch. Note that generated over current may include some amount of direct current.

! CAUTION

- Some installation site may require attachment of an earth leakage breaker. If no earth leakage breaker is installed, it may cause an electric shock.
- Do not use anything other than breaker and fuse with correct capacity. Using fuse and wire or copper wire with too large capacity may cause a malfunction of unit or fire.

Field Wiring

Single outdoor unit

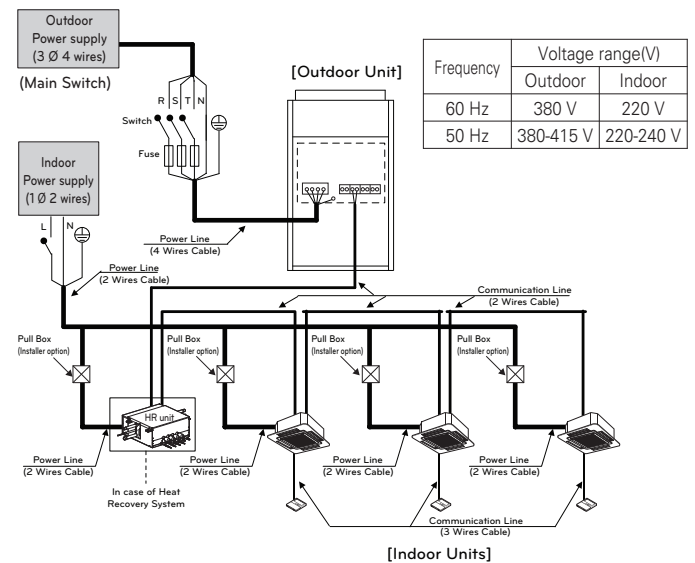

! WARNING

- Indoor Unit ground wires are required for preventing electrical shock accident during current leakage, Communication disorder by noise effect and motor current leakage (without connection to pipe).
- Don't install an individual switch or electrical outlet to disconnect each of indoor unit separately from the power supply.
- Install the main switch that can interrupt all the power sources in an integrated manner because this system consists of the equipment utilizing the multiple power sources.
- If there exists the possibility of reversed phase, lose phase, momentary blackout or the power goes on and off while the product is operating, attach a reversed phase protection circuit locally. Running the product in reversed phase may break the compressor and other parts.

Between Indoor and Outdoor unit

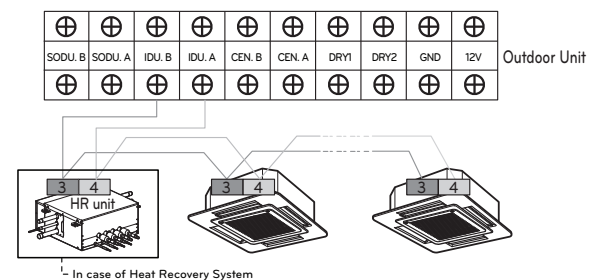

The GND terminal at the main PCB is a 'L' terminal for dry contact, it is not the point to make ground connection.

Example) Connection of transmission wire

[BUS type]

- Connection of communication cable must be installed like below figure between indoor unit to outdoor unit.

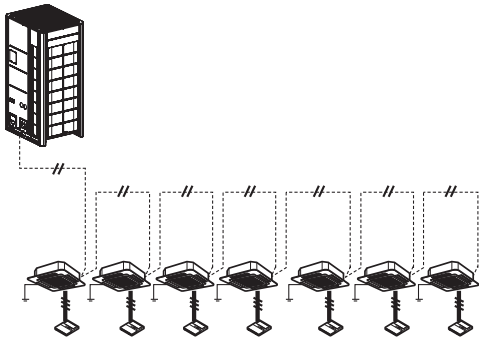

[STAR type]

- Abnormal operation can be caused by communication defect, when connection of communication cable is installed like below figure(STAR type).

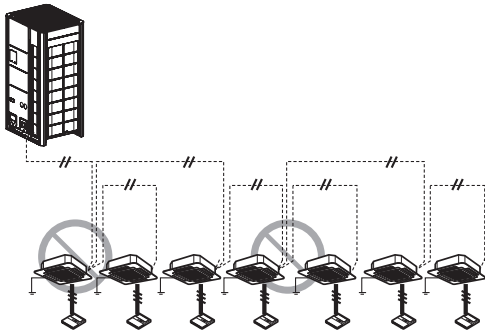

Example) Connection of power and communication cable

Bottom Side

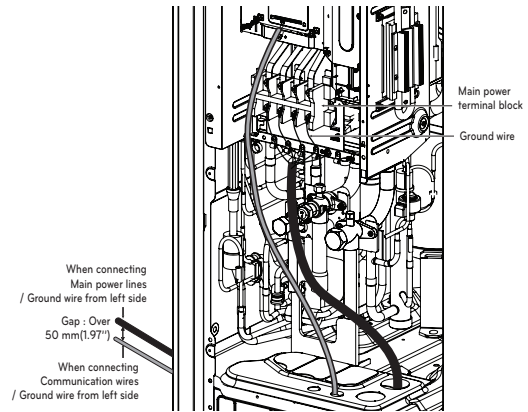

Front Side

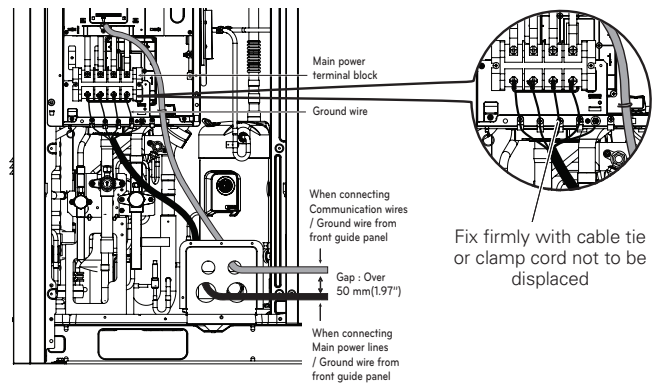

Main power line connection

Communication/ Ground wire connection

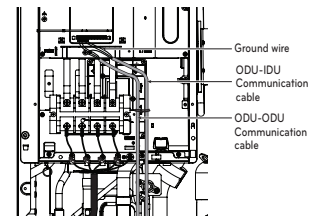
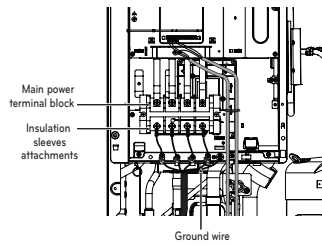

CAUTION

It should be wiring power cables or communication cables to avoid interference with the oil level sensor. Otherwise, That oil level sensor would be operated abnormally.

Checking the setting of outdoor units

Checking according to DIP switch setting

- You can check the setting values of the Master outdoor unit from the 7 segment LED.

The DIP switch setting should be changed when the power is OFF.

Checking the initial display

The number is sequentially appeared at the 7 segment in 5 seconds after applying the power. This number represents the setting condition.

[Main Board]

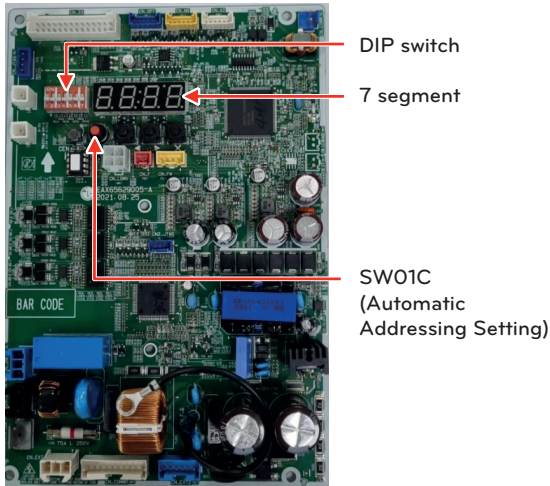

• Communication speed setting

The factory setting of DIP switch 3 differs depending on production date.

- Set the DIP switch 3 to "on" if all the indoor units are "ARN*****4".

- Set the DIP switch 3 to "oFF" if not all the indoor units are "ARN*****4".

DIP switch No. 3	Off	On
Comm. Speed	1200 bps	9600 bps

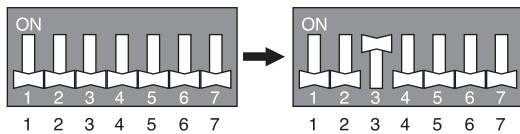
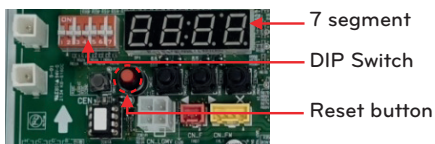

CAUTION

- Set the DIP switch No. 3 "on" and if not all the indoor units are "ARN*****4" connected, normal communication is impossible, so DIP switch No. 3 must be set to "oFF".
- When changing DIP switch, all power should be off and auto addressing must be executed.

• Initial display order

Order	No	Mean
①	8~12	Outdoor Unit capacity
②	8~12	Total capacity
③	3	Heat Pump (Factory Setting)
④	38	380 V model
	46	460 V model
	22	220 V model
⑤	1~255	Model Type (Only Factory)

Example) ZRUM120LTS6

12HP 380V Heat Pump System

①	②	③	④	⑤
12	12	3	38	40

DIP switch setting

Outdoor Unit

DIP switch setting	ODU Setting
	Heat Pump System (Factory Setting)

Heat Recovery installation

① Turn on the DIP s/w No 4.

DIP switch setting	ODU Setting
	Setting Heat pump system or Heat Recovery system (Installer Setting)

② The factory setting display is appeared "HP".

③ Change "HP" into "HR" display pushing ► button and then push confirm button.

④ Turn off the DIP s/w No 4. and Push reset button to restart the system. (If you turn on the DIP s/w No 4, you can make sure "HR" or "HP" display later.)

Setting For Heat Recovery Unit (Refer Only Heat Recovery Installation)

Heat Recovery (HR) Unit Board

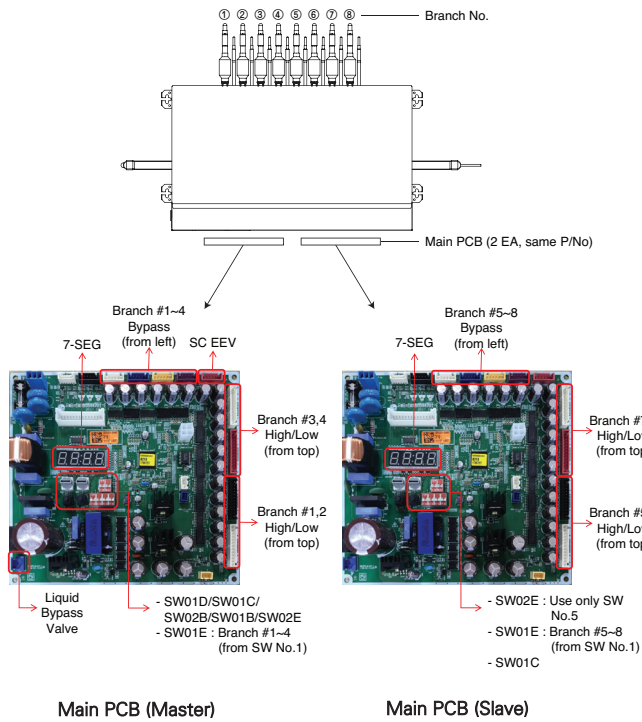

2 Selection of Master/Slave Main PCB

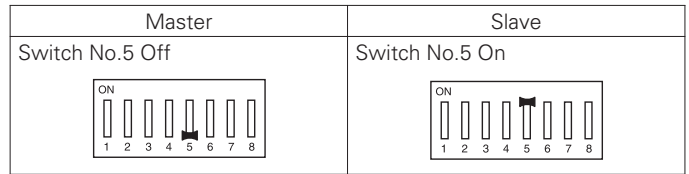

NOTE

Do not turn on any SW02E on Slave Main PCB except No.5.



3 Setting the zoning control

	SW02E setting	SW01E setting
Normal control		
Zoning control		 Turn the DIP switch of the zoning branch on. Ex) Branch 1, 2 are zoning control.

* Zoning control: This function is used to connect multiple indoor units to one pipe.

Switch for setup of HR Unit

Main function of SW02E

ON S/W	Selection
No.1	Method for addressing valves of an HR unit (Auto/Manual)
No.2	No. of connected branches
No.3	
No.4	
No.5	Master/Slave (Main PCB) Setting
No.6	EEPROM factory initialization (4,5,6)
No.7	Use only in factory production (preset to "OFF"), Zoning setting ("ON")
No.8	Use only in factory production (preset to "OFF"), Zoning setting ("ON")

1 Selection of the method for pipe detection of an HR unit (Auto/Manual)

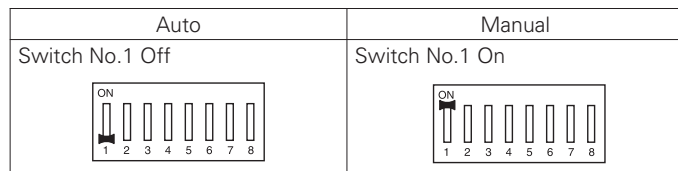

4 Selection of the No. of connected branches

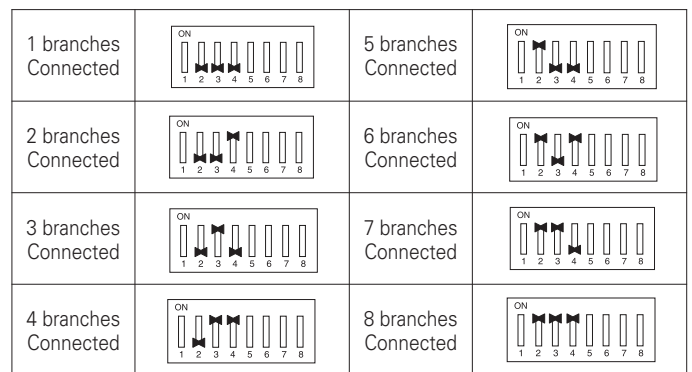

* Each model is shipped with the switches No.2, 3, 4 pre-adjusted as above in the factory.

WARNING

• If you want to use a "Model" for "No. of using branch(es)" HR Unit after closing the "Closing pipe No.", set the DIP switch for "No. of using branch(es)" HR Unit.

Ex) If you want to use a type of 8 port HR unit for 4 branches HR Unit after closing the 5~8th pipes, set the DIP switch for 4 branches HR Unit.

1 Normal setting (Non-Zoning setting)

Ex) Manual pipe detection of Valve #1, 6.

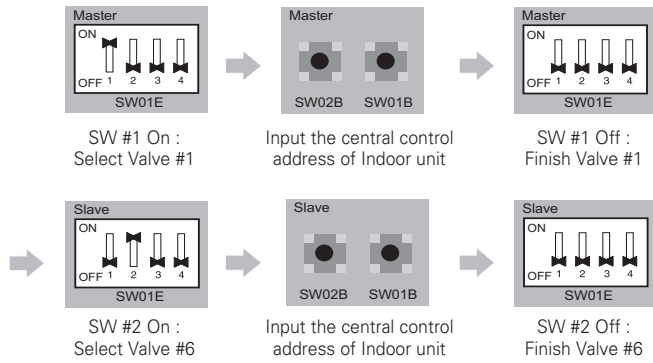

2 Zoning setting

NOTE

Use the Zoning Control when install two or more indoor units at 1 branch of HR Unit.

The indoor units controlled by Zoning Control can be selected collectively as the cooling/heating mode.

Ex) Manual pipe detection of Valve #5 with three zoning indoor units, #6 without zoning unit.

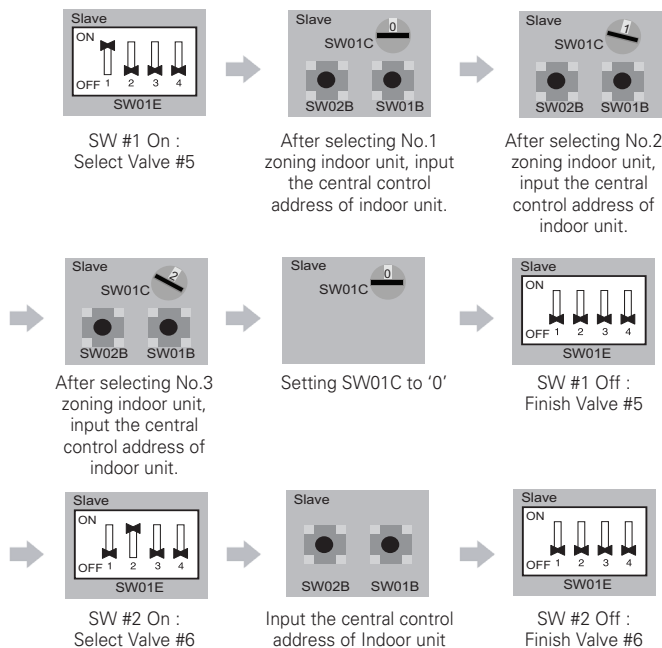

Automatic Addressing

The address of indoor units would be set by Automatic Addressing

- Wait for 3 minutes after supplying power. (Master and Slave outdoor units, indoor units)
- Press RED button of the outdoor units for 5 seconds. (SW01C)
- A "88" is indicated on 7-segment LED of the outdoor unit PCB.
- For completing addressing, 2~7 minutes are required depending on numbers of connected indoor units
- Numbers of connected indoor units whose addressing is completed are indicated for 30 seconds on 7-segment LED of the outdoor unit PCB
- After completing addressing, address of each indoor unit is indicated on the wired remote control display window. (CH01, CH02, CH03,, CH06 : Indicated as numbers of connected indoor units)

[Main Board]

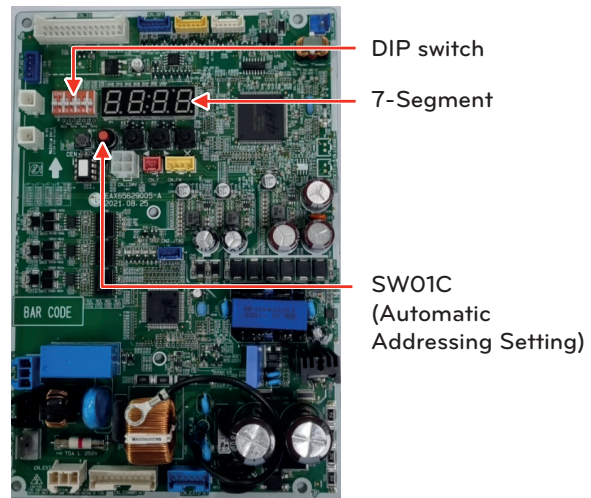

The Procedure of Automatic Addressing

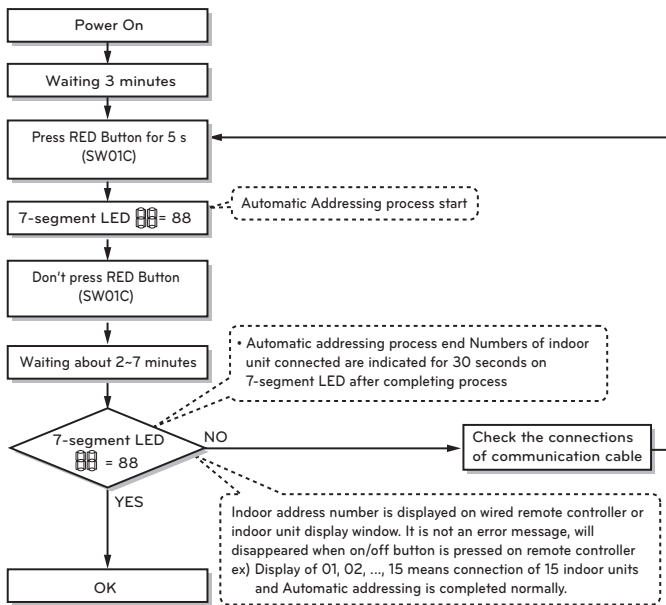

CAUTION

- In replacement of the indoor unit PCB, always perform Automatic addressing setting again (At that time, please check about using Independent power module to any indoor unit.)
- If power supply is not applied to the indoor unit, operation error occur.
- Automatic Addressing has to be performed after more than 3 minutes to improve indoor unit communication when initial power is supplied.
- Please be sure that all the DIP switch (except DIP switch 3) of master outdoor unit is OFF before Automatic Addressing setting
 - Set the DIP switch 3 to "on" if all the indoor units are "ARN*****4".
 - Set the DIP switch 3 to "off" if not all the indoor units are "ARN*****4".

Setting For Heat Recovery Unit (Refer Only Heat Recovery Installation)

Automatic pipe detection (For Heat Recovery System)

- 1 Turn No.1 DIP switch of SW02E of HR unit PCB off.
- 2 Confirm that the setting of No.2, 3, 4 of SW02E corresponds with the type of the valve connection.
- 3 Reset the power of HR unit PCB
- 4 Master outdoor unit PCB DIP switch on : No.5
- 5 Select the mode using '▶', '◀' Button : "Idu" Push the '●' button
- 6 Select the "Id 5" function using '▶', '◀' Button : "Ath" or "Atc" Push the '●' button.
Outdoor temperature is over 15 °C(59°F) : "Ath" Using (If it fail, use "Atc")
Outdoor temperature is below 15 °C(59°F) : "Atc" Using (If it fail, use "Ath")
- 7 Select the mode using '▶', '◀' Button : "Idu" Push the '●' button
- 8 Select the "Id 6" function using '▶', '◀' Button : "StA" Push the '●' button
- 9 System is operated after "88" is displayed on 7-SEG of the outdoor unit main PCB.
- 10 Pipe detection process is proceeded.
- 11 5~30 minutes are required depending on the number of the indoor units and outdoor temperature.

- 12 The number of the indoor units connected is displayed on 7-SEG of the outdoor unit main PCB for about 1 minute
 - For a HR unit, the number of the indoor units connected to each HR unit is displayed.
 - '200' is displayed in case of auto pipe detecting error, and auto pipe detection process is completed when after "88" is disappeared.

WARNING

- Execute auto addressing and auto pipe detection again whenever the indoor PDB and HR unit PCB is replaced.
 - Operation error occurs unless power is supplied to the indoor and HR units.
- Error No.200 occurs if the number of connected indoor units and that of scanned indoor units are different.
- If auto pipe detection process fails, complete it with manual pipe detection (see Manual pipe detection part).
- If auto pipe detection process is completed normally, manual pipe detection is not required.
- If you want to do auto pipe detection again after auto pipe detection fails, do after reset of outdoor unit by all means.
- During 5 minutes after pipe detection is completed, do not turn off the main unit PCB to save the result of pipe detection automatically.

Manual pipe detectio

- 1 Enter the central control address into each indoor unit using its wired remote controller.
- 2 Turn No.1 DIP switch of SW02E of HR unit PCB on.
- 3 Reset the power of HR unit PCB.
- 4 On the HR unit PCB, manually set address of each valve of the HR unit to the central control address of the indoor unit connected to the valve.
- 5 Reset the power of outdoor unit PCB.
- 6 The number of the indoor unit installed is displayed after about 5 minutes.
Ex) HR → The number of the indoor
- 7 Reset the power of outdoor unit PCB, HR unit.
- 8 Manual pipe detection is completed

WARNING

- In case that central controller is not installed, firstly set up central controller's setting to make address setting of indoor units.
- In case that central controller is installed, please set central control address of indoor units by using wired remote controller.
- HR units's manual pipe address is set by the central control address of indoor units.
- Address of valve which is not connected with indoor unit should be set differently with the address of a valve which is indoor unit connected. (If address is overlapped, valve will not work properly)
- If there occurs some error during pipe detection process, it means pipe detection process is not properly finished.
- During 5 minutes after pipe detection process is completed, do not turn off the main outdoor unit's PCB to save the result of pipe detection automatically.

Flow chart of auto pipe detection process

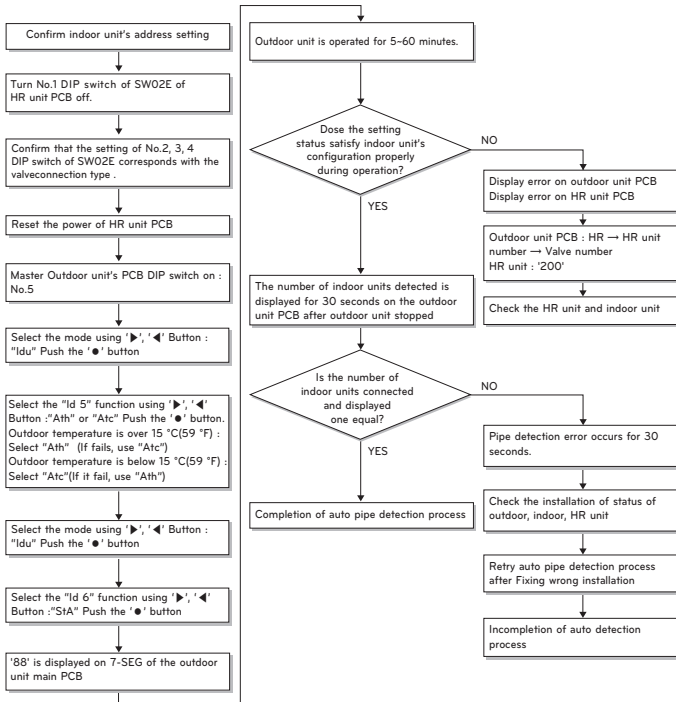

* It is possible to be generated mode changing noise of heating and cooling which is normal. There is no mode changing noise at normal operation.

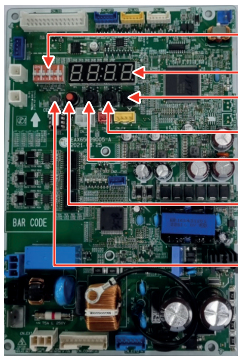

- DIP-SW01
- 7-Segment
- SW04C (X : cancel)
- SW03C (▶: forward)
- SW02C (◀: backward)
- SW01C (●: Confirm / Automatic Addressing)
- SW01D (reset)

Flow chart of manual addressing for pipe detection

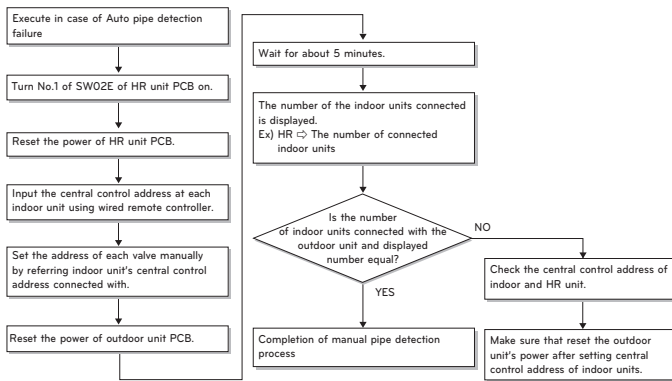

Group Number setting

Group Number setting for Indoor Units

- Confirm the power of whole system(Indoor Unit, Outdoor Unit) is OFF, otherwise turn off.
- The communication cables connected to CEN.A and CEN.B terminal should be connected to central control of Outdoor Unit with care for their polarity (A-A, B-B).
- Turn the whole system on.
- Set the group and Indoor Unit number with a wired remote control.
- To control several sets of Indoor Units into a group, set the group ID from 0 to F for this purpose.

Outdoor Units (External PCB)

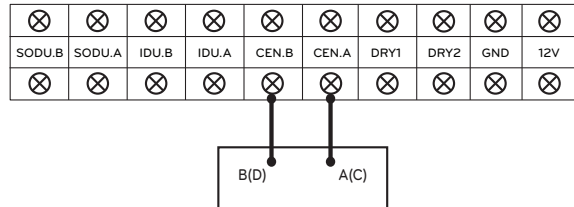

Example) Group number setting

1 E
Group Indoor unit

1st number indicate the group number
2nd number point out indoor unit number

Group recognizing the central controller	
No.0 group (00~0F)	
No.1 group (10~1F)	
No.2 group (20~2F)	
No.3 group (30~3F)	
No.4 group (40~4F)	
No.5 group (50~5F)	
No.6 group (60~6F)	
No.7 group (70~7F)	
No.8 group (80~8F)	
No.9 group (90~9F)	
No. A group (A0~AF)	
No. B group (B0~BF)	
No. C group (C0~CF)	
No. D group (D0~DF)	
No. E group (E0~EF)	
No. F group (F0~FF)	

WARNING

- Valve address and central control address of its corresponding indoor unit should be set identical in manual addressing.

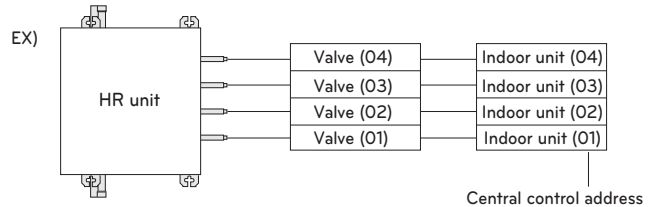

Setting the optional function

Select the mode/function/option/value using '▶', '◀' Button and confirm that using the '●' button after DIP switch No.5 is turned on.

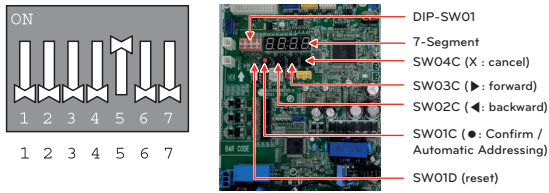

Optional Mode Selection		Function Selection		Option Selection		Remarks
Content	Display (●)	Content	Display (◀, ▶, ●)	Default	Optional (◀, ▶, ●)	
FDD	Fdd	Automatic Refrigerant Charging (Cooling)	Fd1	-	-	* Refer FDD guidance
		Automatic Refrigerant Charging (Heating)	Fd2	-	-	
		Refrigerant Amount Check (Cooling)	Fd3	-	-	
		Refrigerant Amount Check (Heating)	Fd4	-	-	
		ITR (Cooling, Heating)	Fd7	-	-	Compulsory Operation for 1 hour
		All IDU operation (Cooling)	Fd8	-	-	
		All IDU operation (Heating)	Fd9	-	-	
Installation	Func	Cool & Heat Selector	Fn1	oFF	oFF, oP1~oP2	Saving in EEPROM
		High Static Pressure Compensation mode	Fn2	oFF	oFF, oP1~oP3	
		Night Low Noise mode	Fn3	oFF	oFF, oP1~oP12	
		Overall Defrost mode	Fn4	North America: oFF Europe: oFF Tropical: oN	on, oFF	
		ODU address setting	Fn5	0	254	
		Snow Removal & Rapid Defrost	Fn6	oFF	oFF, oP1~oP3	
		Airflow Adjusting for IDU (Heating capacity up)	Fn7	oFF	on, oFF	
		Target Pressure Adjusting	Fn8	oFF	oFF, oP1~oP6	
		Low Ambient Kit	Fn9	oFF	on, oFF	
		Auto Dust Removal Mode	Fn11	oFF	oFF, oP1~oP5	
		Compressor Max. Frequency Limit	Fn12	oFF	oFF, oP1~oP9	
		ODU Fan Max. RPM Limit Mode setting	Fn13	oFF	oFF, oP1~oP7	
		Smart Load Control Mode setting	Fn14	oFF	oFF, oP1~oP3	
		Humidity Reference Mode setting	Fn16	on	on, oFF	
		Central Control Connection at Indoor Unit side	Fn19	oFF	oFF, on	
		Compressor Input Current Limit mode	Fn20	oFF	oFF, oP1~oP10	
		Power Consumption Display on wired remote controller	Fn21	SPL0	SPL0, SPL1 [Pd10~Pd11]	
		Overall Defrost Operating in Low temperature (Heating)	Fn22	oFF	on, oFF	
		Optional Base panel Heater	Fn23	oFF	on, oFF	
Target noise control	Fn45	oFF	oFF, oP1~oP12			
User	IdU	Comfort Cooling Mode setting	Id10	EACH	* Refer Comfort Cooling guidance	Saving in EEPROM
Service	SuL	Vacuum Mode	SE3	vACC	-	1 time / 1 Selection

* Functions save in EEPROM will be maintained continuously, though the system power was reset.

CAUTION

- To perform the optional function should be sure that All the IDU is off mode, unless the function will not be performed.

Cool & Heat selector

Mode setting method

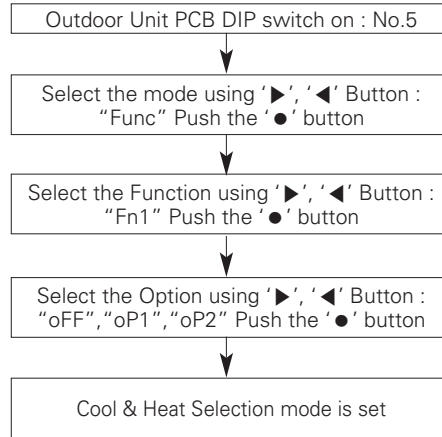

Function setting

Switch Control		Function		
Switch (Up)	Switch (Down)	oFF	oP1 (mode)	oP2 (mode)
Right side (On)	Left side (On)	Not operate	Cooling	Cooling
Right side (On)	Right side (On)	Not operate	Heating	Heating
Left side (Off)	-	Not operate	Fan mode	Off

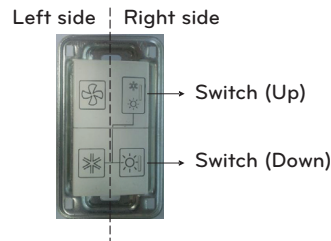

CAUTION

- Ask an authorized technician to setting a function.
- If do not use a function, set an off-mode.
- If use a function, first install a Cool & Heat selector.

High Static Pressure Compensation mode

This function secures the air flow rate of ODU, in case static pressure has been applied like using duct at fan discharge of ODU.

Static pressure compensation mode setting method

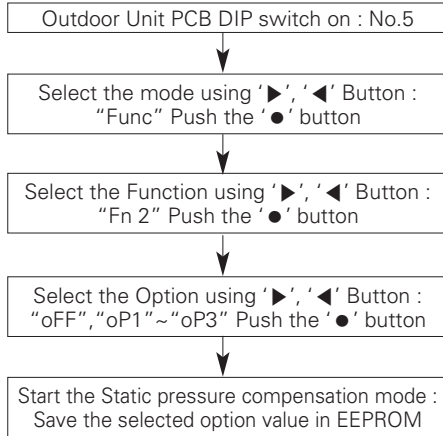

Settings

setting	Static pressure
oFF	0~20 Pa
oP1	21~40 Pa
oP2	41~60 Pa
oP3	61~80 Pa

Night Low Noise Function

In cooling mode, this function makes the ODU fan operate at low RPM to reduce the fan noise of ODU at night which has low cooling load.

Night low noise function setting method

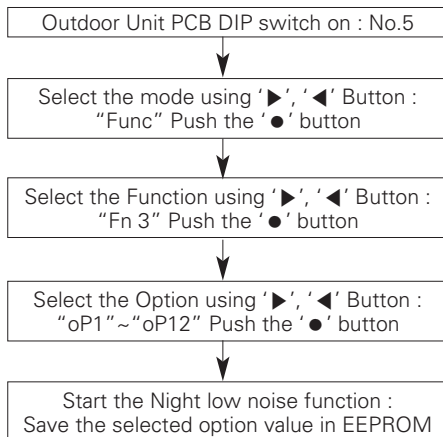

Time Settings

Step	Judgment Time(Hr)	Operation Time(Hr)
oP1	8	9
oP2	6.5	10.5
oP3	5	12
oP4	8	9
oP5	6.5	10.5
oP6	5	12
oP7	8	9
oP8	6.5	10
oP9	5	12
oP10	Continuous operation	
oP11	Continuous operation	
oP12	Continuous operation	

Noise

Step	Noise reduction (dB)
oP1~oP3, oP10	-3
oP4~oP6, oP11	-6
oP7~oP9, oP12	-9

CAUTION

- Request installer to set the function during installation.
- If ODU RPM changes, cooling capacity may go down.

Overall defrost mode

Mode setting method

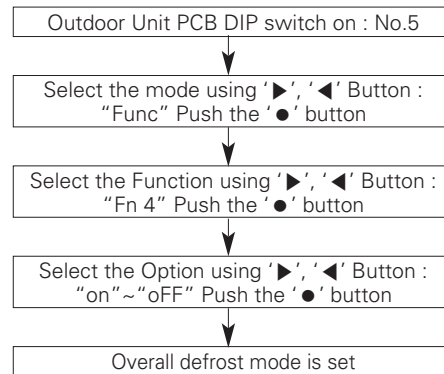

Mode setting

- on: Operate overall defrost
- oFF: Operate partial defrost

CAUTION

- Ask an authorized technician to setting a function.

Setting the ODU address

Mode setting method

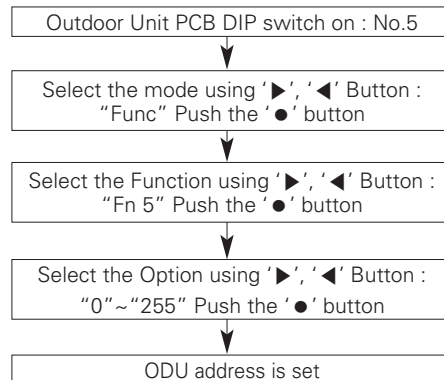

CAUTION

- Ask an authorized technician to setting a function.
- If use a function, first install a Central controller.

Snow removal & rapid defrost

Mode setting method

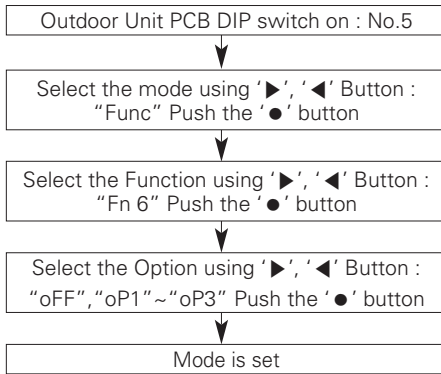

Mode setting

setting	Mode
oFF	Not setting
oP1	Snow removal mode
oP2	Rapid defrost mode
oP3	Snow removal mode. + Rapid defrost mode.

CAUTION

- Ask an authorized technician to setting a function.
- If do not use a function, set an off-mode.

Setting Capacity Up Airflow Adjusting for IDU (Heating)

If the operation of indoor unit is more than 130 %, the air flow is operated as low in the all indoor units.

Mode setting method

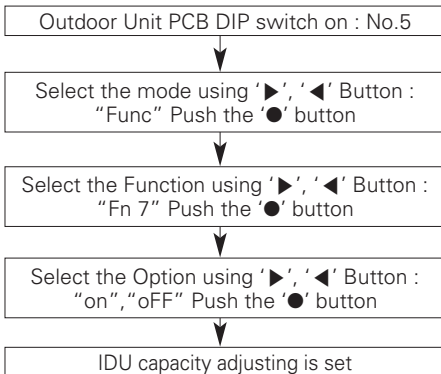

Step	Mode
OFF	Not setting
ON	Low capacity mode

CAUTION

- Ask an authorized technician to setting a function.

Target pressure adjusting

Mode setting method

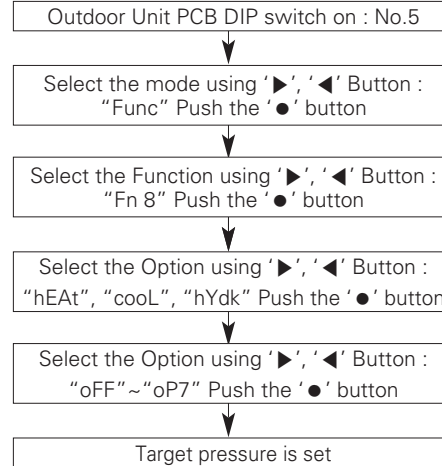

Setting

Mode	Purpose			Evaporating temperature variation	Condensing temperature variation	Condensing temperature variation (Only HDK Operate)
	Cool	Heat	Heat (Only HDK Operate)			
oFF	Equal	Increased Condensing temperature	Equal	-	+4.8 °C (+8.6 °F)	-
oP1	Decreased Evaporating temperature	Increased Condensing temperature	Increased Condensing temperature	-2.9 °C (-5.2 °F)	+6.6 °C (+11.9 °F)	+3.1 °C (+5.6 °F)
oP2	Decreased Evaporating temperature	Increased Condensing temperature	Increased Condensing temperature	-1.4 °C (-2.5 °F)	+5.7 °C (+10.3 °F)	+1.8 °C (+3.2 °F)
oP3	Increased Evaporating temperature	Increased Condensing temperature	Increased Condensing temperature	+2.2 °C (+4.0 °F)	+2.5 °C (+4.5 °F)	+0.9 °C (+1.6 °F)
oP4	Increased Evaporating temperature	Equal	Decreased Condensing temperature	+4.4 °C (+7.9 °F)	-	-2.3 °C (-4.1 °F)
oP5	Increased Evaporating temperature	Decreased Condensing temperature	Decreased Condensing temperature	+6.4 °C (+11.5 °F)	-2.5 °C (-4.5 °F)	-4.8 °C (-8.6 °F)
oP6	Increased Evaporating temperature	Decreased Condensing temperature	Decreased Condensing temperature	+8.4 °C (+15.1 °F)	-5.2 °C (-9.4 °F)	-7.3 °C (-13.1 °F)
oP7	Equal	Increased Condensing temperature	Decreased Condensing temperature	-	+4.8 °C (+8.6 °F)	-10.5 °C (-18.9 °F)

CAUTION

- Ask an authorized technician to setting a function.
- Power consumption is subject to change.

Low Ambient Kit

Mode setting method

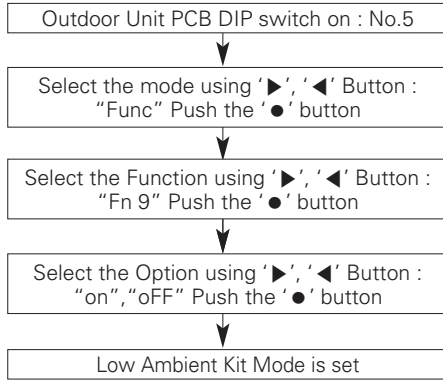

* Reference for functional logic of I/O Module

Auto Dust Removal Mode

The ability to set reverse run outdoor fan to remove dust, heat exchanger.

Mode setting method

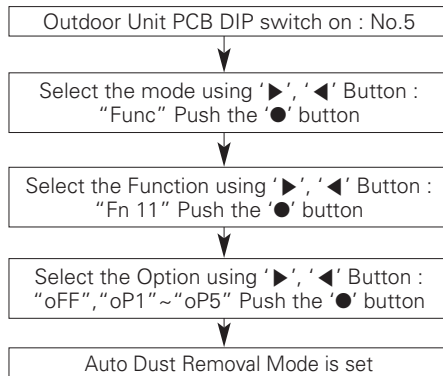

Mode Setting

Setting	Operation time	Operating time	Repeat cycle	Detail of function
oP1	Stop +2 hour	5 minutes	2 hour	After product stopped 2 hour, fan operating 5min(Repeated every 2 hours)
oP2	stop +5 minutes	3 minutes	Twice in 2 hour	After product stopped 5 minutes, fan operating 3 min (Limited to two times within 2 hours)
oP3	stop +5 minutes	3 minutes	1 time	After product stopped 2 hour, fan operating 5min(Repeated every 2 hours)
oP4	Stop +1 minutes	1 minutes	1 time	After product stopped 5 minutes, fan operating 3 min(when io module connection/one-time operation)
oP5	Stop +1 minutes	1 minutes	Low speed	After product stopped 1minutes, fan operating 1 min(every time the product stops)

Compressor Max. Frequency Limit

Mode setting method

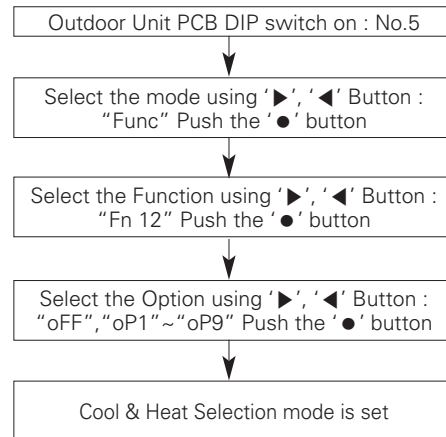

Function setting

Setting	Inverter (Hz)
oFF	-
oP1	143 Hz
oP2	135 Hz
oP3	128 Hz
oP4	120 Hz
oP5	113 Hz
oP6	105 Hz
oP7	98 Hz
oP8	90 Hz
oP9	83 Hz

CAUTION

- Ask an authorized technician to setting a function.
- If use a function, first install a Central controller.

ODU Fan Max. RPM Limit

Mode setting method

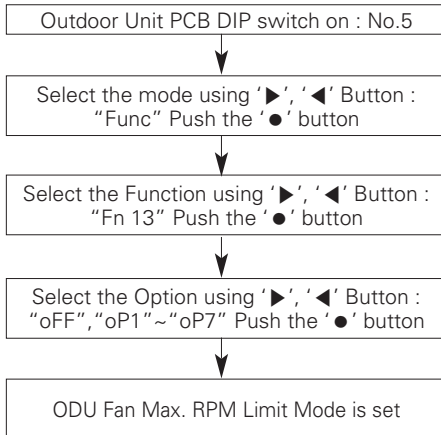

MAX. RPM Limit Setting

Chassis		UXA
Fan MAX. RPM Limit (RPM)	oFF	880
	oP1	-20
	oP2	-40
	oP3	-60
	oP4	-80
	oP5	-100
	oP6	-120
oP7	-140	

SLC (Smart Load Control)

Function for set the variable target pressure which for the high efficiency and comfort operation depend on ODU load.

Mode setting method

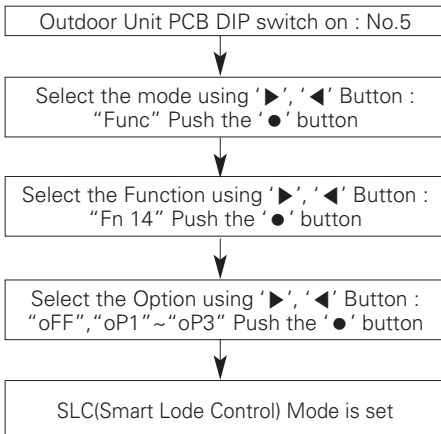

SLC(Smart Load Control) Mode

Setting	Mode	Detail of function
oFF	Not Setting	-
oP1	Smooth Mode	Slowly control, a target pressure value
oP2	Normal Mode	Normal control, a target pressure value
oP3	Peak Mode	Fast control, a target pressure value

Humidity Reference

Mode setting method

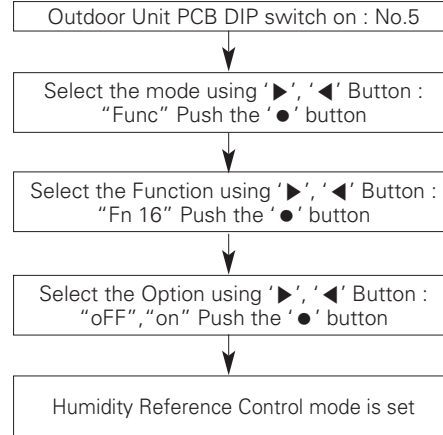

Mode setting

- on:using humidity sensor
- oFF:not setting

<Using of humidity sensor>

- When used cooling operation of SLC function, it will improve energy efficiency because evaporation temperature will be decreased
- When used heating operation in case of high humidity condition, defrost will be delayed because target high/low pressure will be changed.

Central Control Connection at Indoor Unit side

Mode setting method

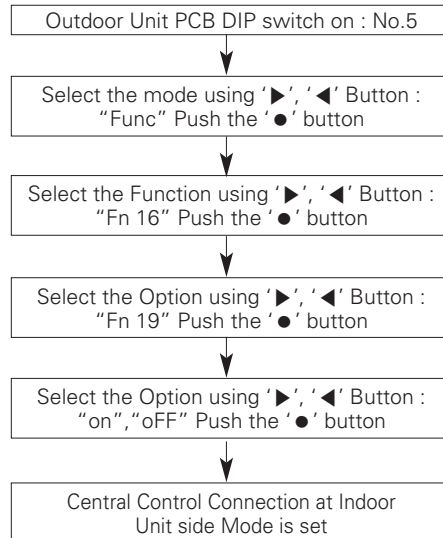

Compressor Input Current Limit

System Input Current Control

Mode setting method

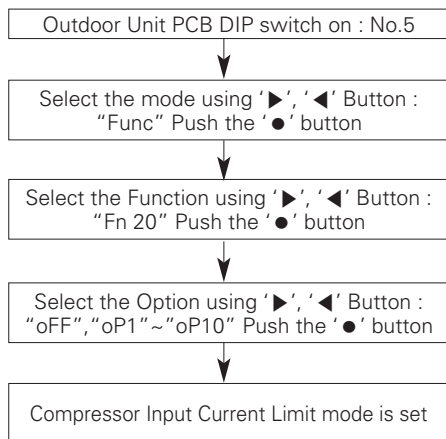

Compressor Input Current Limit

Mode	Compressor Input Current Limit
oP1	95 %
oP2	90 %
oP3	85 %
oP4	80 %
oP5	75 %
oP6	70 %
oP7	65 %
oP8	60 %
oP9	55 %
oP10	50 %

The current limits of each Compressor

Ex)16 A Set oP6 >11.2 A

CAUTION

- Ask an authorized technician to setting a function.
- If do not use a function, set an off-mode.
- If use a function, capacity may go down.

Power Consumption Display on wired remote controller

Mode setting method

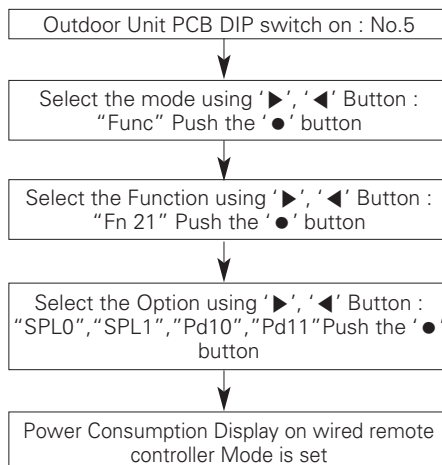

Setting	Detail of function
SPL0	Not used Smart plug logic
SPL1	Using smart plug logic
Pd10	Not installation
Pd11	PDI was installed

Overall Defrost Operating in Low temperature (Heating)

Mode setting method

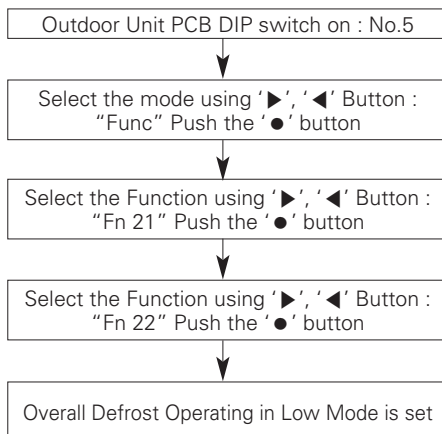

Setting	Detail of function
Default	OFF
Setting	ON/OFF Control

Base pan Heater operation

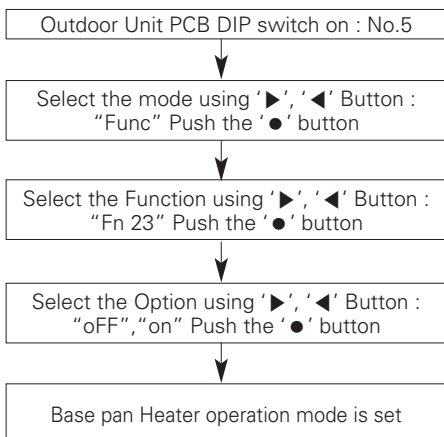

CAUTION

- Function to prevent freezing of ODU base pan in a cold area.
- Heater is accessory. (Sold separately)

Target Noise Control

Mode setting method

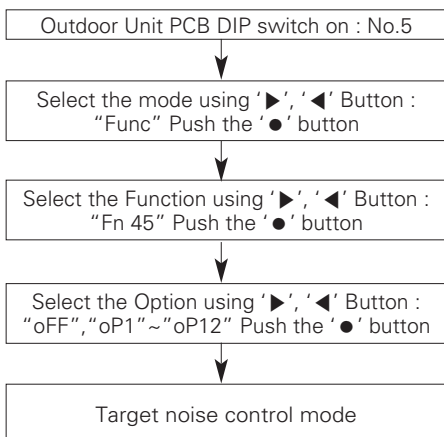

Setting of Maximum noise

Chassis	UXA
HP	8~12
Step	Maximum noise(dB)
oP1~oP3, oP10	59
oP4~oP6, oP11	58
oP7~oP9, oP12	55

Comfort Cooling operation

It is function to reduce the ODU energy consumption by the continuous operation without thermo off.

Mode setting method

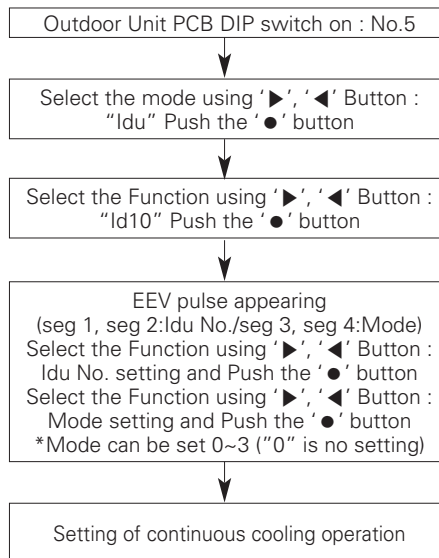

Setting of continuous cooling operation

Mode setting	Effect
0	No setting
1	Cooling capacity low, Power consumption low
2	Cooling capacity mid, Power consumption mid
3	Cooling capacity high, Power consumption high

LG AI engine connection information setting option

This function determines whether or not to use the LG AI engine. (It applies only when the LG AI engine is installed.)
For models equipped with the LG AI engine by default, the models are shipped in the Mode ON status.

Mode setting method

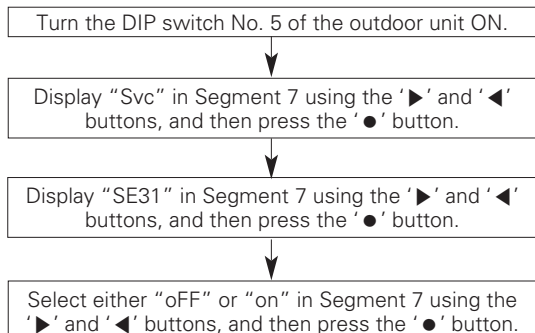

Mode setting

- on: Use when installing the LG AI engine (Default)
 - oFF: Do not use when installing the LG AI engine
- * If the LG AI engine is not installed, the settings won't work.

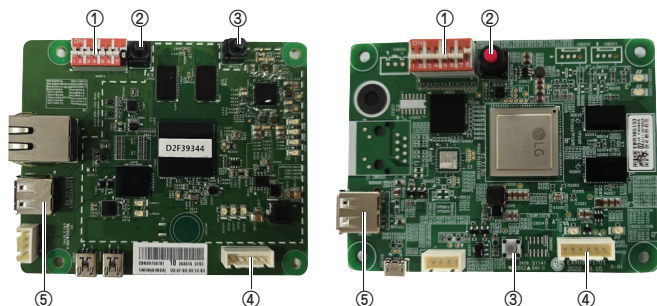

No.	Name	Function
①	DIP Switch	Function setting (when ON is set) 1. Save black box (saving period - 3 months) 2. Save black box (saving period - 6 months) 3. Save large-capacity black box data (USB memory) 4. Save event black box data (USB memory) 5. SW update (USB memory) 6. Reserved 7. Reserved 8. Factory shipment mode(ON) & SW update(OFF) ※ Set 1 month as the black box saving period: Turn DIP Switch No. 1 and No. 2 OFF at the same time (shipment mode)
②	Tact Switch	Check the settings (press and hold down for more than 3 seconds when setting DIP Switches No. 3, 4 and 5)
③	Reset Switch	AI engine booting
④	Main PCB Connection Port	Outdoor unit Main PCB and controller connection terminal
⑤	USB Port	USB port

※ The USB Port and the Ethernet port of the LG AI engine are for service use and are not used during product operation.

LG AI engine function

The LG AI engine provides the best comfort and energy savings by acquiring, analyzing and learning system data, also black box data saving with large space.

Black box

- **Large capacity black box function**
10 Gbyte capacity can be saved.
Data can be saved for 1 month, 3 months, and 6 months using the DIP Switch.
 - **Event black box function**
1 Gbyte capacity can be saved.
Data are saved from 1 hour before and up to 30 minutes after the occurrence of an error. Up to 100 error occurrence data can be saved.
- ※ Black box data can be moved using USB.

AI smart care Comfort

The AI operation to control the airflow from the indoor unit for 10 minutes during cooling/heating operation by learning the surrounding situation is carried out.

- For the model that automatically controls the air flow from the indoor unit, only the ceiling cassette air conditioner is supported.
- The comfort level may vary depending on the model, capacity, and the environment.

Energy Savings

The AI operation to maintain comfort levels while saving energy by collecting and learning the ambient temperature, humidity, and load is carried out.

- Energy savings may vary depending on the model, capacity and the environment.

Display of energy savings

The energy savings (power, kWh) by the AI smart care operation are displayed on the wired remote control. (RS3)

- The displayed value is the power consumption amount for the entire system.
 - The predicted saving is a value calculated by analyzing the pattern of energy usage according to the use of the AI smart care operation.
 - There may be a difference when compared to the actual usage, so use it only as a reference.
 - If you need accurate usage, install PDI (LG product) Power Distribute Indication additionally.
When installing PDI, you should set the function by referring to the outdoor unit installation manual. (Smart plug function, settings: PDI1)
- For detailed settings, refer to the user/installation manual for the wired remote controller (RS3).

Guidance to open source software

To obtain the GPL, LGPL, MPL, and other source codes distributed to open source licenses for which the source codes shall be disclosed, or to check the license contents and copyright notices for the open source, please visit <https://opensource.lge.com>.

In addition, if a consumer sends an e-mail to opensource@lge.com to request the open source code of the software installed in this product, LG Electronics receives the minimum cost required for delivery, such as media costs and transportation costs, and contains it in a storage medium in order to provide same. This offer is valid for anyone who receives this information within 3 years of selling the product.

LGE Open Source Software Notice

Product Type	Air-conditioner
Model Name/Range	LG AI Engine for Air Conditioner(PACTLA000)

Open Source	Licenses	Copyright
acl 2.2.52	GPL-2.0 LGPL-2.1	Copyright (c) 1999-2002 Andreas Gruenbacher, <a.gruenbacher@bestbits.at> Copyright (c) 2000-2002 Silicon Graphics, Inc.
attr 2.4.47	GPL-2.0 LGPL-2.1	Copyright (c) 2002 Andreas Gruenbacher <agruen@suse.de>, SuSE Linux AG. Copyright (c) 2001-2003,2005 Silicon Graphics, Inc. Copyright (c) 2002 Andreas Gruenbacher <agruen@suse.de>, SuSE Linux AG. Copyright (c) 2001-2003,2005 Silicon Graphics, Inc.
base-files 3.0.14	GPL-2.0	Copyright (c) 2016 Yocto Project, A Linux Foundation Collaborative Project.
base-passwd 3.5.29	GPL-2.0	Copyright (c) 1999-2002 Wichert Akkerman <wichert@deephackmode.org> Copyright (c) 2002, 2003, 2004 Colin Watson <cjwatson@debian.org>
bash 3.2.57	GPL-2.0	Copyright (c) 1987-2005 Free Software Foundation, Inc.
BusyBox 1.27.2	GPL-2.0	Copyright (c) 1999-2005, Erik Andersen <andersen@codepoet.org>
codeaurora-imx-optee-test 4.14.98	BSD-2-Clause GPL-2.0	Copyright (c) 2014, STMicroelectronics International N.V. Copyright (c) 2015-2016, Linaro Limited Copyright (c) 2014, STMicroelectronics International N.V. Copyright (c) 2016, Linaro Limited Copyright (c) 2018 NXP
e2fsprogs 1.43.8	GPL-2.0 LGPL-2.1 MIT-like License (e2fsprogs)	Copyright (c) 1995-2010, Theodore Ts'o
fsl-rc-local	GPL-2.0	
glibc 2.27	GPL-2.0 LGPL-2.1	Copyright (c) 2017-2018 Free Software Foundation, Inc.
kmod 25	GPL-2.0 LGPL-2.1	Copyright (c) 2011-2013 ProFUSION embedded systems Copyright (c) 2013 Intel Corporation
libusb 1.0.21	LGPL-2.1	Copyright (c) 2007-2008 Daniel Drake <dsd@gentoo.org> Copyright (c) 2001 Johannes Erdfelt <johannes@erdfelt.com>
Linux Kernel 4.14	GPL-2.0	-
linux-imx 4.14.98	GPL-2.0	-
Log library for C++ 1.1.2	LGPL-2.1	Copyright (c) 2000, LifeLine Networks BV (www.lifeline.nl) Copyright (c) 2000, Bastiaan Bakker.
lrzsz 0.12.20	GPL-2.0	
lzo 2.10	GPL-2.0	Copyright (C) 1996 - 2017 Markus Franz Xavier Johannes Oberhumer
netbase 5.4	GPL-2.0	Copyright (c) 1994-2010, Peter Tobias, Anthony Towns and Marco d'Itri
opkg-utils 0.3.6	GPL-2.0	Copyright (c) 2006-2007, Paul Sokolovsky
rng-tools 5	GPL-2.0	
systemd 237	GPL-2.0 LGPL-2.1	Copyright (c) 2010~2016 Lennart Poettering. Copyright (c) 2017 Zbigniew J. drzejewski-Szmek
systemd-serialgetty	LGPL-2.1	
update-rc.d 0.7	GPL-2.0	Copyright (c) 2003, 2004 Phil Blundell <pb@handhelds.org>

Open Source	Licenses	Copyright
usbutils 009	GPL-2.0	Copyright (c) 2009-2011 Nikolai Kondrashov
Util-Linux 2.32.1	BSD-3-Clause GPL-2.0 LGPL-2.1	Copyright (c) 2007,2008,2009,2010,2011,2014 Karel Zak <kzak@redhat.com> Copyright (C) 1994-2002 Kevin E. Martin & aeb Copyright (c) 2000-2001 Gunnar Ritter Copyright (c) 2004 Kay Sievers <kay.sievers@vrfy.org> Copyright (c) 2001 by Andreas Dilger Copyright (c) 2014 Ondrej Oprala <ooprala@redhat.com> Copyright (c) 1999,2000,2003 Theodore Ts'o. Copyright (c) 1999 by Andries Brouwer
bzip2 1.0.8	bzip2-1.0.6	Copyright (c) 1996-2019 Julian R Seward.
codeaurora-imx-optee-client 4.14.98	BSD-2-Clause	Copyright (c) 2015, Linaro Limited
codeaurora-imx-optee-os 4.14.98	BSD-2-Clause	Copyright (c) 2015, Linaro Limited
curl 7.86.0	curl	Copyright (c) 1996 - 2021, Daniel Stenberg, <daniel@haxx.se> , and many contributors
dbus 1.12.2	AFL-2.1	Copyright (C) 2003 CodeFactory AB Copyright (C) 2002, 2003, 2004 Red Hat Inc. Copyright (C) 2007 Ralf Habacker <ralf.habacker@freenet.de> Copyright (C) 2003 Philip Blundell <philb@gnu.org> Copyright (C) 2006 Thiago Macieira <thiago@kde.org> Copyright (C) 2011 Nokia Corporation Copyright (C) 2005 Novell, Inc.
expat 2.2.5	MIT	Copyright (c) 1998-2000 Thai Open Source Software Center Ltd and Clark Cooper Copyright (c) 2001-2017 Expat maintainers
Freescale-yocto-udev-rules-imx	MIT	-
libarchive 3.4.2	BSD-2-Clause	Copyright (c) 2003-2007 Tim Kientzle Copyright (c) 2012 Michihiro NAKAJIMA
libcap 2.25	BSD-3-Clause	Copyright (c) 1997-1999, 2007-2011, 2016, Andrew G. Morgan <morgan@kernel.org> Copyright (c) 2010, Serge Hallyn <serue@us.ibm.com> Copyright (c) 1998, Finn Arne Gangstad <finnag@guardian.no> Copyright (c) 1997, Aleph One
libtirpc 1.0.2	BSD-3-Clause	Copyright (c) 2005, Bull S.A.
libxml2 2.9.7	MIT	Copyright (c) 1998-2012 Daniel Veillard.
ncurses 6.2	MIT-like License (ncurses)	Copyright (c) 1998-2017,2018 Free Software Foundation, Inc.
nginx 1.12.2	BSD-2-Clause	Copyright (c) Nginx, Inc. Copyright (c) Igor Sysoev
openssh 7.6p1	OpenSSH License	
openssl 1.1.0i	OpenSSL	Copyright (c) 1998-2018 The OpenSSL Project. Copyright (c) 1995-1998 Eric Young (eay@cryptsoft.com)
pcre 8.44	BSD-3-Clause	Copyright (c) 1997-2020 University of Cambridge Copyright (c) 2010-2018 Zoltan Herczeg Copyright (c) 2007-2012, Google Inc.
rpcbind 0.2.4	BSD-3-Clause	Copyright (c) 2005, Bull S.A.
run-postinsts 1.0	MIT	Copyright (c) 2007 Openedhand Ltd.
shadow 4.6	Artistic-1.0 BSD-3-Clause	Copyright (c) 2007 - 2011, Nicolas François Copyright (c) 1989 - 1994, Julianne Frances Haugh Copyright (c) 1991 - 1993, Chip Rosenthal Copyright (c) 1996 - 2000, Marek Michalkiewicz Copyright (c) 2000 - 2007, Tomasz Kloczko Copyright (c) 2004 The FreeBSD Project.
shadow-securetty 4.6	MIT	-

Open Source	Licenses	Copyright
udev-extraconf 1.1	MIT	
volatile-binds 1.0	MIT	-
zlib 1.2.11	Zlib	Copyright (c) 1995-2017 Jean-loup Gailly and Mark Adler
acl 2.3.1	GPL-2.0 LGPL-2.1	(C) 1999 Andreas Gruenbacher, <a.gruenbacher@computer.org>
alsa-lib 1.2.6.1	LGPL-2.1	Copyright (c) 2008-2010 SlimLogic Ltd Copyright (c) 2010 Wolfson Microelectronics PLC Copyright (c) 2010 Texas Instruments Inc. Copyright (c) 2010 Red Hat Inc. Copyright (c) 1998-2007, Jaroslav Kysela <perex@perex.cz> Copyright (c) 1999, Uros Bizjak <uros@kss-loka.si> Copyright (c) 1998-2007, Takashi Iwai <tiwai@suse.de> Copyright (c) 1992, Stichting Mathematisch Centrum, Amsterdam, The Netherlands. Copyright (c) 2000-2002 Richard W.E. Furse, Paul Barton-Davis, Stefan Westerfeld. Copyright (c) 2000-2003, Abramo Bagnara <abramo@alsa-project.org> Copyright (c) 2014-2015 Intel Corporation
alsa-utils 1.2.6	GPL-2.0	Copyright (c) 2018 Takashi Sakamoto <o-takashi@sakamocchi.jp> Copyright (c) 2013-2016 Intel Corporation Copyright (c) 1999-2000, 2003, Takashi Iwai Copyright (c) 2004-2006, 2009-2010, Clemens Ladisch <clemens@ladisch.de> Copyright (c) 1998,1999 Tim Janik Jaroslav Kysela <perex@perex.cz>
attr 2.5.1	GPL-2.0	Copyright (c) 2009 Andreas Gruenbacher <agruen@suse.de> Copyright (c) 2001, 2002, 2003, 2006 Silicon Graphics, Inc. Copyright (c) 2007 Free Software Foundation
BusyBox 1.36.1	GPL-2.0	Copyright (c) 1999-2004 by Erik Andersen. Copyright (c) 2005-2006 Rob Landley Copyright (c) 2004 Kay Sievers <kay.sievers@vrfy.org> Copyright (c) 1991, 1993 The Regents of the University of California.
e2fsprogs 1.46.5	GPL-2.0	Copyright (c) 1993-1997 Theodore Ts'o. Copyright (c) 1993 1994 Remy Card <card@masi.ibp.fr> Laboratoire MASI Institut Blaise Pascal Universite Pierre et Marie Curie
glibc 2.35	LGPL-2.1	Copyright (c) 1917-2022 Free Software Foundation, Inc.
kbd 2.4.0	GPL-2.0	Copyright (c) 1989, 1991 Free Software Foundation, Inc.
kmod 29	GPL-2.0 LGPL-2.1	Copyright (c) 2011-2013 ProFUSION embedded systems Copyright (c) 2013 Intel Corporation
libseccomp 2.5.3	LGPL-2.1	Copyright (c) 2012,2018 Red Hat <pmoore@redhat.com>
libxcrypt 4.4.30	LGPL-2.1	Copyright (c) 1994 David Burren Copyright (c) 2018-2020 Bjorn Esser <besser82@fedoraproject.org> Copyright (c) 2018 vt@altlinux.org
Linux Kernel 5.15.130	GPL-2.0	
logrotate 3.20.1	GPL-2.0	Copyright (c) 1995-2001 Red Hat, Inc. Copyright (c) 1991, 1993 The Regents of the University of California.
LZMA Utils 5.2.6	GPL-2.0	
lzo 2.1	GPL-2.0	Copyright (c) 1996-2017 Markus Franz Xaver Johannes Oberhumer
nfs-utils 2.6.1	GPL-2.0	Copyright (c) 1994-2020 Free Software Foundation Inc. Copyright (c) 2004 The Regents of the University of Michigan Copyright (c) 2010 Oracle America Inc.
rng-tools 6.15	GPL-2.0	Copyright (C) 2001 Philipp Rumpf
sysstat 12.7.5	GPL-2.0	Copyright (c) 1999-2019 by Sebastien GODARD (sysstat orange.fr)
systemd 250.5	LGPL-2.1	Copyright (c) 2013-2015 Intel Corporation. Copyright (c) 2010 Ran Benita Copyright (c) 2012 Harald Hoyer <harald@redhat.com>

Open Source	Licenses	Copyright
Util-Linux 2.37.4	GPL-2.0	Copyright (c) 1989, 1991 Free Software Foundation, Inc. Copyright (c) 2007-2013 Karel Zak Copyright (c) 1999 Andries Brouwer Copyright (c) 1999, 2000, 2003 Theodore Ts'o Copyright (c) 2001 Andreas Dilger Copyright (c) 2004 Kay Sievers
android-bionic 4.4	BSD-2-Clause BSD-3-Clause	Copyright (c) 2008 The Android Open Source Project Copyright (c) 1990, 1993 The Regents of the University of California.
android-system-core 9.0	Apache-2.0 BSD-2-Clause BSD-3-Clause BSD-like License (android-system-core-toolbox)	Copyright (c) 2010 The Android Open Source Project
android-system-memory-libion	Apache-2.0	Copyright (c) 2011 Google, Inc.
android-tools 5.1.1	Apache-2.0	Copyright (c) 2006-2012, The Android Open Source Project Copyright (c) 2012 Samsung Electronics Co., Ltd.
arm-trusted-firmware 1.5	BSD-3-Clause	Copyright (c) 2013-2018, ARM Limited and Contributors.
Boost 1.78.0	BSL-1.0	Copyright (c) 2003-2021 Christopher M. Kohlhoff (chris at kohlhoff dot com) Copyright (c) 2013-2021 Vinnie Falco Copyright (c) 1998-2011 Joel de Guzman
bzip2 1.0.8	bzip2-1.0.6	Copyright (c) 1996-2019 Julian R Seward.
curl 8.5.0	curl	Copyright (c) 1996 - 2023, Daniel Stenberg, <daniel@haxx.se> , and many contributors Copyright (c) Daniel Stenberg, <daniel@haxx.se>
dbus 1.14.8	AFL-2.1	Copyright (c) 1992-2014 Free Software Foundation, Inc. Copyright (c) 2003 Philip Blundell Copyright (c) 2003-2006 Red Hat, Inc. Copyright (c) 2006 Thiago Macieira Copyright (c) 2008-2012 Nokia Corporation Copyright (c) 2008-2013 Collabora Ltd. Copyright (c) 2002 Michael Meeks Copyright (c) 1994 X Consortium Copyright (c) 2005, 2010 Lennart Poettering Copyright (c) 2002, 2003 CodeFactory AB Copyright (c) 2005 Novell, Inc. Copyright (c) 2009 Klaralvdalens Datakonsult AB, a KDAB Group company, info@kdab.net Copyright (c) 2007, Tanner Lovelace Copyright (c) 2008, Colin Walters Copyright (c) 2008-2009, Benjamin Reed Copyright (c) 2013 Intel Corporation Copyright (c) 2000 Werner Almesberger Copyright (c) 1991-1993 The Regents of the University of California. Copyright (c) 1994 Sun Microsystems, Inc. Copyright (c) 2006 Christian Ehrlicher Copyright (c) 2005 g10 Code GmbH Copyright (c) 1995 A. M. Kuchling Copyright (c) 2006-2013 Ralf Habacker Copyright (c) 2004 Eric Poech Copyright (c) 2004 Robert Shearman Copyright (c) 2004 Imendio HB Copyright (c) 2009 Yaakov Selkowitz Copyright (c) 2008 Laurent Montel, Copyright (c) 2011, Raphael Kubo da Costa Copyright (c) 2006, Tim Beaulen Copyright (c) 2004-2005 Scott James Remnant
dropbear 2020.81	MIT	Copyright (c) 2002-2015 Matt Johnston Copyright (c) 2004 Mihnea Stoenescu Copyright (c) 1995 Tatu Ylonen <ylo@cs.hut.fi>, Espoo, Finland Copyright (c) 1997-2003 Simon Tatham.

Open Source	Licenses	Copyright
dtc-libfdt 1.4.4	BSD-2-Clause	Copyright (C) 2006 David Gibson, IBM Corporation.
Eclipse Paho MQTT C client 1.3.10	BSD-3-Clause	Copyright (c) 2009-2020, IBM Corp.
expat 2.5.0	MIT	Copyright (c) 1998-2000 Thai Open Source Software Center Ltd and Clark Cooper Copyright (c) 2001-2022 Expat maintainers
flac 1.3.1	BSD-3-Clause	Copyright (c) 2011-2014 Xiph.Org Foundation Copyright (c) 2000-2009 Josh Coalson Copyright (c) 1998 Todd C. Miller <Todd.Miller@courtesan.com> Copyright (c) 2002-2009 Daisuke Shimamura Copyright (c) 1998-2000 Peter Alm, Mikael Alm, Olle Hallnas, Thomas Nilsson and 4Front Technologies Copyright (c) 2000-2002 Jerome Couderc <j.couderc@ifrance.com> Copyright (c) 1999-2001 Håvard Kvålen <havardk@xmms.org> Copyright (c) 2001 Edmund Grimley Evans <edmund@rano.org> Copyright (c) 2002 John Edwards Additional code Magnus Holmgren and Gian-Carlo Pascutto Copyright (c) 2001 Peter Harris <peter.harris@hummingbird.com> Copyright (c) 2001 David Robinson and Glen Sawyer Copyright (c) 1987-1999 Free Software Foundation, Inc. Copyright (c) 2003 Philip Jägenstedt Copyright (c) 2000-2001 Robert Leslie
FreeRTOS 10.4.3	MIT	Copyright (c) 2020 Amazon.com, Inc.
icu 70.1	Unicode-DFS-2016	Copyright (c) 1995-2016, International Business Machines Corporation and others Copyright (c) 1991-2021, Unicode, Inc.
Jansson 2.13.1	MIT	Copyright (c) 2009-2016 Petri Lehtinen
jitterentropy-library 3.4.0	BSD-3-Clause	Copyright (c) 2017 - 2019, Stephan Mueller <smueller@chronox.de>
libarchive 3.6.2	BSD-2-Clause	Copyright (c) 2003-2018 Tim Kientzle Copyright (c) 2008-2014 Michihiko NAKAJIMA Copyright (c) 2016-2020 Martin Matuska Copyright (c) 2007-2010 Joerg Sonnenberger Copyright (c) 2011-2014, Mike Kazantsev
libbsd 0.11.5	Beerware BSD-2-Clause BSD-3-Clause BSD-4-Clause ISC MIT	
libcap 2.66	BSD-3-Clause	Copyright (c) 1997-9,2007-8,2019,2021 Andrew G Morgan <morgan@kernel.org> Copyright (c) 1997 Andrew Main <zefram@dcs.warwick.ac.uk>
libmd 1.0.4	Beerware BSD-2-Clause BSD-3-Clause ISC	Copyright Colin Plumb Todd C. Miller Copyright (c) 2001 Markus Friedl Copyright (c) 2009, 2011, 2016 Guillem Jover <guillem@hadrons.org> Copyright (c) 1997, 2003, 2004 Todd C. Miller <Todd.Miller@courtesan.com> Copyright (c) 2001 The NetBSD Foundation, Inc. Copyright Poul-Henning Kamp <phk@login.dkuug.dk> Copyright (c) 2000-2001, Aaron D. Gifford Copyright Steve Reid <steve@edmweb.com> Copyright Colin Plumb
libsamplerate 0.2.2	BSD-2-Clause	Copyright (c) 2012-2016, Erik de Castro Lopo <erikd@mega-nerd.com>
libsolv 0.7.22	BSD-3-Clause	Copyright (c) 2007-2017 Novell Inc. Copyright (c) 2013-2020, SUSE LLC.
libxml2 2.11.4	MIT	Copyright (c) 1998-2012 Daniel Veillard
LK	MIT	Copyright (c) 2008-2015 Travis Geiselbrecht

Open Source	Licenses	Copyright
mbed-os 5.6	Apache-2.0	Copyright (c) 2016 STMicroelectronics Copyright (c) 2015, Freescale Semiconductor, Inc.
mbed-os 5.2	Apache-2.0	Copyright (c) STMicroelectronics Copyright (c) 2015, Freescale Semiconductor, Inc. Copyright (c) 2017 Silicon Laboratories, Inc. http://www.silabs.com
minini 1.2	Apache-2.0	
ncurses 6.4	MIT-like License (ncurses)	Copyright 2018-2021,2022 Thomas E. Dickey Copyright 1998-2017,2018 Free Software Foundation, Inc.
openssh 9.6p1	OpenSSH License	Copyright (c) 1995, Tatu Ylonen <ylo@cs.hut.fi> , Espoo, Finland Copyright (c) 1995, Patrick Powell Copyright (c) 1995, 1996, David Mazieres <dm@lcs.mit.edu> Copyright (c) 1983, 1990, 1992, 1993, 1995 The Regents of the University of California
openssl 3.2.1	Apache-2.0	Copyright (c) 1998-2017 The OpenSSL Project. Copyright (c) 1995-1998 Eric Young (eay@cryptsoft.com)
openssl 1.0.1j	OpenSSL	
optee_client 3.4.0	BSD-2-Clause	Copyright (c) 2015, Linaro Limited
optee_os 3.2.0	BSD-2-Clause	Copyright (c) 2015 Linaro Limited
Opus 1.2.1	BSD-3-Clause	Copyright (c) 2006-2011, Skype Limited. Copyright (c) 2007-2008, CSIRO Copyright (c) 2007-2013, Xiph.Org Foundation Copyright (c) 2008-2012, Gregory Maxwell Copyright (c) 2008-2011, Octasic Inc. Copyright (c) 2002-2012, Jean-Marc Valin Copyright (c) 2001-2011, Timothy B. Terriberry Copyright (c) 2003-2004, Mark Borgerding Copyright (c) 2001 Erik de Castro Lopo
popt 1.18	X11	Copyright (c) 1998, Red Hat Software
ringgaard-sanos 1.3.4	BSD-3-Clause	Copyright (c) 2002 Michael Ringgaard.
shadow 4.11.1	BSD-3-Clause	Copyright (c) 1989 - 1994, Julianne Frances Haugh Copyright (c) 1996 - 2001, Marek Michalkiewicz Copyright (c) 2001 - 2006, Tomasz Kloczko Copyright (c) 2004 The FreeBSD Project Copyright (c) 1997, Guy Maor <maor@ece.utexas.edu> Copyright (c) 2007 - 2013, Nicolas François Copyright (c) 1991 - 1993, Chip Rosenthal
tremor 1.0.2	BSD-3-Clause	Copyright (c) 2002, Xiph.org Foundation
zlib 1.2.13	Zlib	Copyright (c) 2004 Henrik Ravn Copyright (c) 2002-2003 Dmitry Anisimkov Copyright (c) 1995-2022 Mark Adler
zstd 1.5.2	BSD-3-Clause	Copyright (c) 2016-2021 Yann Collet Facebook Inc. Copyright (c) 2016-present Facebook Inc.

Self-Diagnosis Function

Error Indicator

- This function indicates types of failure in self-diagnosis and occurrence of failure for air condition.
- Error mark is displayed on display window of indoor units and wired remote controller, and 7-segment LED of outdoor unit control board as shown in the table.
- If more than two troubles occur simultaneously, lower number of error code is first displayed.
- After error occurrence, if error is released, error LED is also released simultaneously.

Error Display

1st, 2nd, 3rd LED of 7-segment indicates error number, 4th LED indicates unit number.

Ex) 1051 : Error occurrence with error number 105 at No. 1 outdoor unit
In case of indoor unit error occurrence, the error number is only shown at remote controller without 7 segment LED of outdoor unit.

Ex) CH → 01 : Error occurrence with error number 01 (at remote controller)
In case of compressor error occurrence, 7 segment LED of outdoor unit control board will display its error number alternately with compressor number.



* Refer to the DX-Ventilation manual for DX-Ventilation error code.

Display			Title	Cause of Error	
Indoor unit related error	0	1	-	Air temperature sensor of indoor unit	Air temperature sensor of indoor unit is open or short
	0	2	-	Inlet pipe temperature sensor of indoor unit	Inlet pipe temperature sensor of indoor unit is open or short
	0	3	-	Communication error : wired remote controller ↔ indoor unit	Failing to receive wired remote controller signal in indoor unit PCB
	0	4	-	Drain pump	Malfunction of drain pump
	0	5	-	Communication error : outdoor unit ↔ indoor unit	Failing to receive outdoor unit signal in indoor unit PCB
	0	6	-	Outlet pipe temperature sensor of indoor unit	Outlet pipe temperature sensor of indoor unit is open or short
	0	8	-	Hydro Kit Hot water storage tank Temperature sensor	Pipe temperature sensor is open or short
	0	9	-	Indoor EEPROM Error	In case when the serial number marked on EEPROM of Indoor unit is 0 or FFFFFF
	1	0	-	Poor fan motor operation	Disconnecting the fan motor connector / Failure of indoor fan motor lock
	1	1	-	Communication error : Hydro Kit Indoor unit ↔ Inv.PCB	Failing to receive Inv. PCB signal in indoor unit
	1	2	-	Hydro Kit Inv.PCB error	Hydro Kit Inv.PCB error
	1	3	-	Hydro Kit Solar heat piping temperature sensor error	Pipe temperature sensor is open or short
	1	4	-	Hydro Kit Indoor unit Flow switch error	Flow switch flow detection error
	1	5	-	Hydro Kit Liquid pipe Strange overheat Error	Temperature sensor defective or hot water inflow
	1	6	-	Hydro Kit Indoor unit Inlet and Outlet pipe Temperature sensor Error	Pipe temperature sensor is open or short
	Outdoor unit related error	2	1	*	Outdoor Unit Inverter Compressor IPM Fault
2		2	*	Inverter PCB Input Over Current(RMS) of Master Outdoor Unit	Outdoor Unit Inverter PCB Input Current excess (RMS)
2		3	*	Outdoor Unit Inverter Compressor DC Link Low or High Voltage	System is turned off by Master Outdoor Unit DC Link Low/High Voltage.
2		4	*	Outdoor Unit High Pressure Switch	System is turned off by Master Outdoor Unit high pressure switch.
2		5	*	Outdoor Unit Input Voltage High/ Low Voltage	Over 537 V or below 247 V (ARUM***LTE6) Over 310 V or below 143 V (ARUM***BTE6) Over 598 V or below 320 V (ARUM***DTE6)

Display			Title	Cause of Error	
Outdoor unit related error	2	6	*	Outdoor Unit Inverter Compressor Start Failure	The first start failure by Outdoor Unit Inverter Compressor abnormality or Compressor locked
	2	9	*	Outdoor Unit Inverter Compressor Over Current	Outdoor Unit Inverter Compressor Fault OR Drive Fault
	3	2	*	Outdoor Unit Inverter Compressor 1 High Discharge Temperature	Outdoor Unit Inverter Compressor 1 High Discharge Temperature
	3	3	*	Outdoor Unit Inverter Compressor 2 High Discharge Temperature	Outdoor Unit Inverter Compressor 2 High Discharge Temperature
	3	4	*	High Pressure of Outdoor Unit	High Pressure of Outdoor Unit
	3	5	*	Low Pressure of Outdoor Unit	Low Pressure of Outdoor Unit
	4	0	*	Outdoor Unit Inverter Compressor CT Sensor Fault	Outdoor Unit Inverter Compressor CT Sensor open or short
	4	1	*	Outdoor Unit Inverter Compressor1 Discharge Temperature Sensor Fault	Outdoor Unit Inverter Compressor Discharge Temperature Sensor open or short
	4	2	*	Outdoor Unit Low Pressure Sensor Fault	Outdoor Unit Low Pressure Sensor open or short
	4	3	*	Outdoor Unit High Pressure Sensor Fault	Outdoor Unit High Pressure Sensor open or short
	4	4	*	Outdoor Unit Air Temperature Sensor Fault	Outdoor Unit Air Temperature Sensor open or short
	4	5	*	Outdoor Unit Heat Exchanger Temperature Sensor (Front side) Fault	Outdoor Unit Heat Exchanger Temperature Sensor(Front side) open or short
	4	6	*	Outdoor Unit Suction Temperature Sensor Fault	Outdoor Unit Suction Temperature Sensor open or short
	4	7	*	Outdoor Unit Inverter Compressor 2 Discharge Temperature Sensor Fault	Outdoor Unit Inverter Compressor 2 Discharge Temperature Sensor open or short
	4	9	*	Outdoor Unit Faulty IPM Temperature Sensor	Outdoor Unit IPM Temperature Sensor short/open
	5	0	*	Omitting connection of R, S, T power of Outdoor Unit	Omitting connection of outdoor unit
	5	1	*	Excessive capacity of indoor units	Excessive connection of indoor units compared to capacity of Outdoor Unit
	5	2	*	Communication error : inverter PCB → Main PCB	Failing to receive inverter signal at main PCB of Outdoor Unit
	5	3	*	Communication error : indoor unit → Main PCB of Outdoor Unit	Failing to receive indoor unit signal at main PCB of Outdoor Unit.
	5	7	*	Communication error : Main PCB → inverter PCB	Failing to receive signal main PCB at inverter PCB of Outdoor Unit
	6	0	*	Inverter PCB EEPROM Error of Master Outdoor Unit	Access Error of Inverter PCB of Outdoor Unit
	6	2	*	Outdoor Unit Inverter Heatsink High Temperature	System is turned off by Outdoor Unit Inverter Heatsink High Temperature
	6	5	*	Outdoor Unit Inverter Heatsink Temperature Sensor Fault	Outdoor Unit Inverter Heatsink Temperature Sensor open or short
	6	7	*	Outdoor Unit Fan Lock	Restriction of Outdoor Unit
	7	1	*	Inverter CT Sensor Error of Master Outdoor Unit	Inverter CT Sensor open or short of Outdoor Unit
	7	5	*	Outdoor Unit Fan CT Sensor Error	Outdoor Unit Fan CT Sensor open or short
	7	7	*	Outdoor Unit Fan Over Current Error	Outdoor Unit Fan Current is over 6 A
	7	9	*	Outdoor Unit Fan Start Failure Error	The first start failure by Outdoor Unit Fan abnormality or Fan locked
	8	6	*	Outdoor Unit Main PCB EEPROM Error	Communication Fail Between Outdoor Unit Main MICOM and EEPROM or omitting EEPROM
	8	7	*	Outdoor Unit Fan PCB EEPROM Error	Communication Fail Between Outdoor Unit Fan MICOM and EEPROM or omitting EEPROM
1	0	4	*	Communication Error Between Outdoor Unit and Other Outdoor Unit	Failing to receive Slave Unit signal at main PCB of Outdoor Unit
1	0	5	*	Outdoor Unit Fan PCB Communication Error	Failing to receive fan signal at main PCB of Outdoor unit
1	0	6	*	Outdoor Unit Fan IPM Fault Error	Instant Over Current at Outdoor Unit Fan IPM

Display				Title	Cause of Error	
Outdoor unit related error	1	0	7	*	Outdoor Unit Fan DC Link Low Voltage Error	Outdoor Unit Fan DC Link Input Voltage is under 380 V
	1	1	3	*	Outdoor Unit Liquid pipe Temperature Sensor Error	Liquid pipe temperature sensor of Outdoor Unit is open or short
	1	1	4	*	Outdoor Unit Subcooling Inlet Temperature Sensor Error	Outdoor Unit Subcooling Inlet Temperature Sensor Error
	1	1	5	*	Outdoor Unit Subcooling Outlet Temperature Sensor Error	Outdoor Unit Subcooling Outlet Temperature Sensor Error
	1	1	6	*	Outdoor Unit Oil Level Sensor Error	Oil Level Sensor of Outdoor Unit is open or short
	1	4	5	*	Outdoor unit Main Board - External Board communication Error	Outdoor unit Main Board - External Board communication Error
	1	5	0	*	Outdoor Unit Discharge Superheat not satisfied	Outdoor Unit Compressor Discharge Superheat not satisfied during 5 Min.
	1	5	1	*	Failure of operation mode conversion at Outdoor Unit	Failure of operation mode conversion at Outdoor Unit
	1	5	3	*	Outdoor Unit Heat Exchanger Temperature Sensor (upper part) Fault	Outdoor Unit Heat Exchanger Temperature Sensor (upper part) Fault
	1	5	4	*	Outdoor Unit Heat Exchanger Temperature Sensor (lower part) Fault	Outdoor Unit Heat Exchanger Temperature Sensor(lower part) open or short
	1	8	2	*	Outdoor unit External Board Main-Sub Micom communication Error	Outdoor Unit Main Board Main-Sub Micom communication failed
	1	8	7	*	Hydro - Kit P,HEX bursting error	Inlet water temperature is below 5 degree or water temperature error during defrosting operation.
	1	9	3	*	Outdoor Unit Fan Heatsink High Temperature	System is turned off by Outdoor Unit Fan Heatsink High Temperature
1	9	4	*	Outdoor Unit Fan Heatsink Temperature Sensor Fault	Outdoor Unit Fan Heatsink Temperature Sensor open or short	
HR Unit related error	2	0	0	1	Searching pipe Error	Failure of automatic addressing of valves
	2	0	1	C+#HR	HR unit 1 Liquid sensor error	Liquid pipe sensor of HR unit open or short
	2	0	2	C+#HR	HR unit 1 Sub Cooling Pipe sensor error	Sub Cooling Pipe In sensor of HR unit open or short
	2	0	3	C+#HR	HR unit 1 Sub Cooling Pipe Out sensor error	Sub Cooling Pipe Out sensor of HR unit. open or short
	2	0	4	C+#HR	Communication error	Failing to receive HR unit signal at outdoor unit
Network error	2	4	2	*	Network error of central controller	Communication wiring defect
	2	5	2	*	Defective communication between the indoor unit main PCB ↔ AI engine PCB.	It occurs when a communication signal between the outdoor unit main PCB and AI engine is not received.

C: HR unit

#: HR unit Number

SPECIAL REQUIREMENTS

Flow chart

For Installation

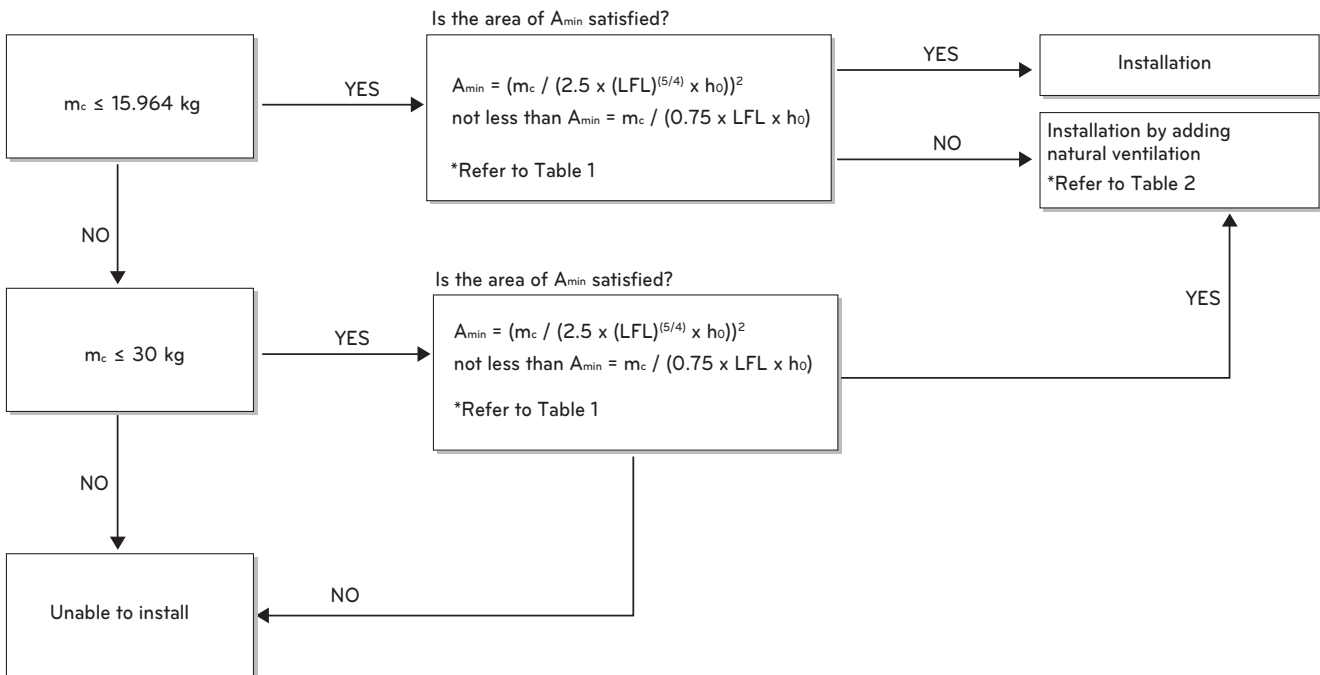

A_{min} = Minimum installation required area

m_c = Total amount of refrigerant in the system (kg)

LFL(Lower Flammability Limit)(kg/m³) = 0.307 kg/m³

h_o : The Vertical Distance from the floor to the point of Release (m)

Table 1 (Minimum installation required area)

Total amount of refrigerant in the system (kg)	Minimum installation required area (m ²)	
	Ceiling mounted (h _o : 2.2 m)	Wall mounted (h _o : 1.8 m)
8.50	45.74	68.32
8.60	46.82	69.94
8.80	49.02	73.23
9.00	51.28	76.60
9.20	53.58	80.04
9.40	55.94	83.56
9.60	58.34	87.15
9.80	60.80	90.82
10.00	63.30	94.56
10.20	65.86	98.39
10.40	68.47	102.28
10.60	71.13	106.25
10.80	73.84	110.30
11.00	76.60	114.42
11.20	79.41	118.62
11.40	82.27	122.90
11.60	85.18	127.25
11.80	88.14	131.67
12.00	91.16	136.17
12.20	94.22	140.75
12.40	97.34	145.40
12.60	100.50	150.13
12.80	103.72	154.93
13.00	106.98	159.81
13.20	110.30	164.77
13.40	113.67	169.80
13.60	117.09	174.91
13.80	120.56	180.09
14.00	124.08	185.35
14.20	127.65	190.68
14.40	131.27	196.09
14.60	134.94	201.57
14.80	138.66	207.13
15.00	142.43	212.77
15.20	146.26	218.48
15.40	150.13	224.27
15.60	154.06	230.13
15.80	158.03	236.07
15.964*	161.33	241.00
16.00	162.06	242.09
16.20	166.13	248.18
16.40	170.26	254.34
16.60	174.44	260.58
16.80	178.67	266.90
17.00	182.95	273.29
17.20	187.28	279.76
17.40	191.66	286.30
17.60	196.09	292.92
17.80	200.57	299.62
18.00	205.10	306.39
18.20	209.69	313.24
18.40	214.32	320.16
18.60	219.01	327.16
18.80	223.74	334.23
19.00	228.53	341.38
19.20	233.36	348.60
19.40	238.25	355.90
19.60	243.19	363.28
19.80	248.18	370.73
20.00	253.21	378.26
20.20	258.30	385.86
20.40	263.44	393.54
20.60	268.64	401.29

Total amount of refrigerant in the system (kg)	Minimum installation required area (m ²)	
	Ceiling mounted (h _o : 2.2 m)	Wall mounted (h _o : 1.8 m)
21.00	279.17	417.03
21.20	284.51	425.01
21.40	289.91	433.07
21.60	295.35	441.20
21.80	300.84	449.41
22.00	306.39	457.69
22.20	311.99	466.05
22.40	317.63	474.49
22.60	323.33	483.00
22.80	329.08	491.59
23.00	334.88	500.25
23.20	340.73	508.99
23.40	346.63	517.80
23.60	352.58	526.69
23.80	358.58	535.65
24.00	364.63	544.69
24.20	370.73	553.81
24.40	376.88	563.00
24.60	383.09	572.27
24.80	389.34	581.61
25.00	395.65	591.03
25.20	402.00	600.52
25.40	408.41	610.09
25.60	414.87	619.74
25.80	421.37	629.46
26.00	427.93	639.26
26.20	434.54	649.13
26.40	441.20	659.08
26.60	447.91	669.10
26.80	454.67	679.20
27.00	461.48	689.38
27.20	468.35	699.63
27.40	475.26	709.95
27.60	482.22	720.36
27.80	489.24	730.83
28.00	496.30	741.39
28.20	503.42	752.02
28.40	510.58	762.72
28.60	517.80	773.50
28.80	525.07	784.36
29.00	532.38	795.29
29.20	539.75	806.30
29.40	547.17	817.38
29.60	554.64	828.54
29.80	562.16	839.77
30.00	569.73	851.08

* If m_c > 15.964, must add natural ventilation

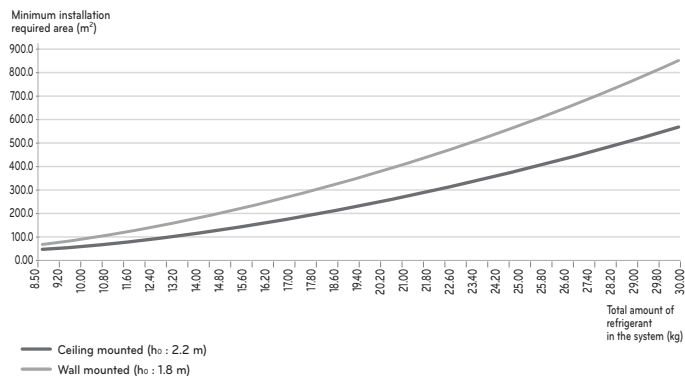
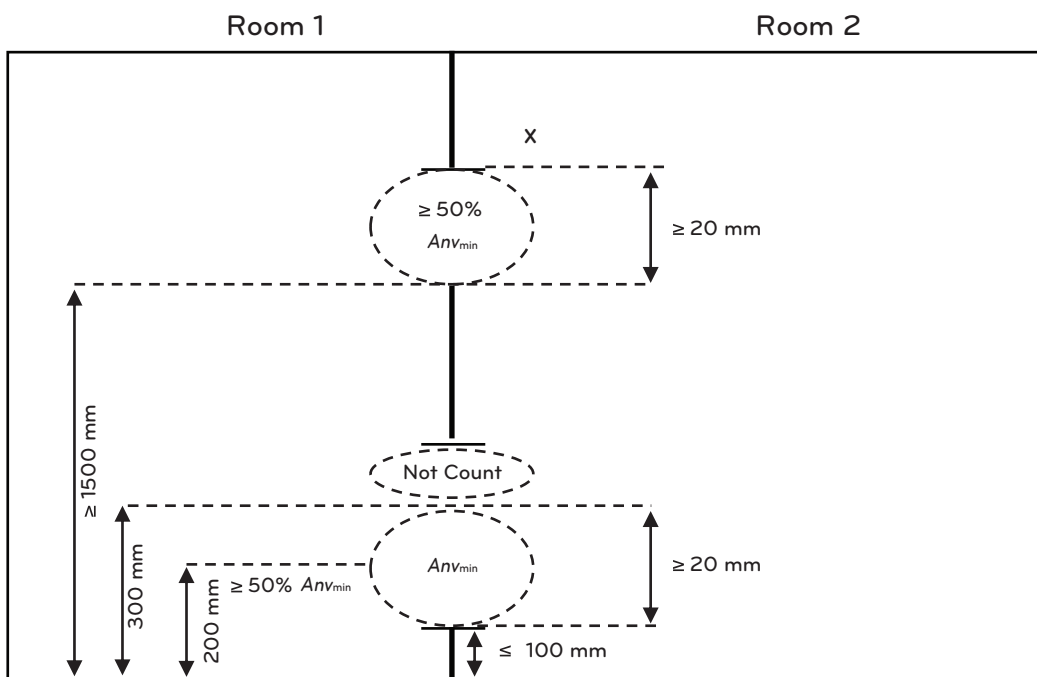

Table 2 (Minimum installation required area)**For the lower opening:**

- It is not an opening to the outside
- The opening cannot be closed
- The opening must be $\geq Anv_{min}$
- The area of any openings above 300 mm from the floor does not count when determining Anv_{min}
- At least 50% of Anv_{min} is less than 200 mm above the floor
- The bottom of the lower opening is ≤ 100 mm from the floor
- The height of the opening is ≥ 20 mm

For the upper opening:

- It is not an opening to the outside
- The opening cannot be closed
- The opening must be $\geq 50\%$ of Anv_{min}
- The bottom of the upper opening must be $\geq 1\ 500$ mm above the floor
- The height of the opening is ≥ 20 mm

**Minimum opening area (Anv)**

$$Anv_{min} = \frac{m_c - m_{max}}{LFL \times 104} \times \sqrt{\frac{A}{g \times m_{max}} \frac{M}{M - 29}}$$

Anv Is the minimum opening for natural ventilation in m^2 .

m_c Is the actual refrigerant charge of refrigerant in the system in kg;

m_{max} Is the allowable maximum refrigerant charge in the system in kg, calculated according to Equation GG.8 or m^2 , whichever is lower,

LFL Is the lower flammability limit in kg/m^3 ;

A Is the room area in m^2 ;

M Is the molar mass of the refrigerant in $kg/kmol$;

g Is the gravity acceleration of $9,81 m/s^2$;

29 Is the average molar mass of air in $kg/kmol$.

INSTALLATION GUIDE AT THE SEASIDE

CAUTION

- Air conditioners should not be installed in areas where corrosive gases, such as acid or alkaline gas, are produced.
- Do not install the product where it could be exposed to sea wind (salty wind) directly. It can result corrosion on the product. Corrosion, particularly on the condenser and evaporator fins, could cause product malfunction or inefficient operation.
- If outdoor unit is installed close to the seaside, should avoid direct exposure to the sea wind.

Selecting the location(Outdoor Unit)

If the outdoor unit is to be installed close to the seaside, direct exposure to the sea wind should be avoided. Install the outdoor unit on the opposite side of the sea wind direction.

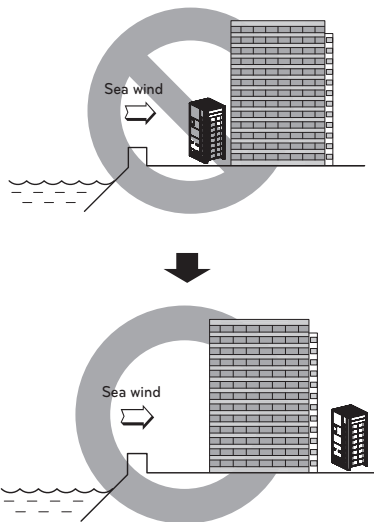

In case, to install the outdoor unit on the seaside, set up a windbreak not to be exposed to the sea wind.

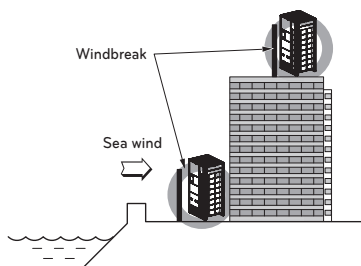

- It should be strong enough like concrete to prevent the sea wind from the sea.
- The height and width should be more than 150 % of the outdoor unit.
- It should be kept more than 70 cm (2.3 ft) of distance between outdoor unit and the windbreak for smooth air flow.

Select a well-drained place.

- Periodic (1 times per 6 month) cleaning of the dust or salt particles stuck on the heat exchanger is necessary by using clean water

Model Designation

Product information

- Product Name : Air conditioner
- Model Name :

Product Sales Name	Model Factory Name
ZRUX***LTy6 series	
x	= N (Heat Pump), V (Cooling Only), M (Heat Recovery / Heat Pump)
y	= S (Basic function), E (Additional function related to performance)
***	= Numeric; (Cooling capacity)

- Additional information : Serial number is refer to the bar code on the product.

Airborne Noise Emission

The A-weighted sound pressure emitted by this product is below 70 dB.

** The noise level can vary depending on the site.

The figures quoted are emission level and are not necessarily safe working levels.

Whilst there is a correlation between the emission and exposure levels, this cannot be used reliably to determine whether or not further precautions are required.

Factor that influence the actual level of exposure of the workforce include the characteristics of the work room and the other sources of noise, i.e. the number of equipment and other adjacent processes and the length of time for which an operator exposed to the noise. Also, the permissible exposure level can vary from country to country.

This information, however, will enable the user of the equipment to make a better evaluation of the hazard and risk.



Manufacturer :
LG Electronics Inc.
84, Wanam-ro, Seongsan-gu, Changwon-si, Gyeongsangnam-do, KOREA

UK Importer :
LG Electronics U.K. Ltd
Velocity 2, Brooklands Drive, Weybridge, KT13 0SL

Eco design requirement

- The information for Eco design is available on the following free access website.
<https://www.lg.com/global/support/cedoc/cedoc>