



ENGLISH

FRANÇAIS

ESPAÑOL

INSTALLATION MANUAL

# AIR CONDITIONER

Please read this installation manual completely before installing the product.  
Installation work must be performed in accordance with the national wiring standards  
by authorized personnel only.

Please retain this installation manual for future reference after reading it thoroughly.

**MULTI V<sup>™</sup>**

For Heat Pump / Heat Recovery system  
Original instruction



MFL69717901  
Rev.04\_071025

[www.lghvac.com](http://www.lghvac.com)  
[www.lg.com](http://www.lg.com)

Copyright © 2020 - 2025 LG Electronics Inc. All Rights Reserved.

## TIPS FOR SAVING ENERGY

Here are some tips that will help you minimize the power consumption when you use the air conditioner. You can use your air conditioner more efficiently by referring to the instructions below:

- Do not cool excessively indoors. This may be harmful for your health and may consume more electricity.
- Block sunlight with blinds or curtains while you are operating the air conditioner.
- Keep doors or windows closed tightly while you are operating the air conditioner.
- Adjust the direction of the air flow vertically or horizontally to circulate indoor air.
- Speed up the fan to cool or warm indoor air quickly, in a short period of time.
- Open windows regularly for ventilation as the indoor air quality may deteriorate if the air conditioner is used for many hours.
- Clean the air filter once every 2 weeks. Dust and impurities collected in the air filter may block the air flow or weaken the cooling / dehumidifying functions.

### *For your records*

Staple your receipt to this page in case you need it to prove the date of purchase or for warranty purposes. Write the model number and the serial number here:

Model number : \_\_\_\_\_

Serial number : \_\_\_\_\_

You can find them on a label on the side of each unit.

Dealer's name : \_\_\_\_\_

Date of purchase : \_\_\_\_\_

## IMPORTANT SAFETY INSTRUCTIONS

### **READ ALL INSTRUCTIONS BEFORE USING THE APPLIANCE.**

Always comply with the following precautions to avoid dangerous situations and ensure peak performance of your product.

#### **⚠ WARNING**

It can result in serious injury or death when the directions are ignored.

#### **⚠ CAUTION**

It can result in minor injury or product damage when the directions are ignored.

#### **⚠ WARNING**

- Installation or repairs made by unqualified persons can result in hazards to you and others. Installation of all field wiring and components **MUST** conform with local building codes or, in the absence of local codes, with the National Electrical Code 70 and the National Building Construction and Safety Code or Canadian Electrical code and National Building Code of Canada.
- The information contained in the manual is intended for use by a qualified service technician familiar with safety procedures and equipped with the proper tools and test instruments.
- Failure to carefully read and follow all instructions in this manual can result in equipment malfunction, property damage, personal injury and/or death.

### Installation

- Have all electric work done by a licensed electrician according to "Electric Facility Engineering Standard" and "Interior Wire Regulations" and the instructions given in this manual and always use a special circuit.
  - If the power source capacity is inadequate or electric work is performed improperly, electric shock or fire may result.
- Ask the dealer or an authorized technician to install the air conditioner.
  - Improper installation by the user may result in water leakage, electric shock, or fire.
- Always ground the product.
  - There is risk of fire or electric shock.
- Always install a dedicated circuit and breaker.
  - Improper wiring or installation may cause fire or electric shock.
- For re-installation of the installed product, always contact a dealer or an Authorized Service Center.
  - There is risk of fire, electric shock, explosion, or injury.
- Do not install, remove, or re-install the unit by yourself (customer).
  - There is risk of fire, electric shock, explosion, or injury.
- Do not store or use flammable gas or combustibles near the air conditioner.
  - There is risk of fire or failure of product.
- Use the correctly rated breaker or fuse.
  - There is risk of fire or electric shock.
- Prepare for strong wind or earthquake and install the unit at the specified place.
  - Improper installation may cause the unit to topple and result in injury.
- Do not install the product on a defective installation stand.
  - It may cause injury, accident, or damage to the product.
- Use a vacuum pump or Inert(nitrogen) gas when doing leakage test or air purge. Do not compress air or Oxygen and do not use Flammable gases. Otherwise, it may cause fire or explosion.
  - There is the risk of death, injury, fire or explosion.
- When installing and moving the air conditioner to another site, do not charge it with a different refrigerant from the refrigerant specified on the unit.
  - If a different refrigerant or air is mixed with the original refrigerant, the refrigerant cycle may malfunction and the unit may be damaged.
- Do not reconstruct to change the settings of the protection devices.
  - If the pressure switch, thermal switch, or other protection device is shorted and operated forcibly, or parts other than those specified by LGE are used, fire or explosion may result.
- Ventilate before operating air conditioner when gas leaked out.
  - It may cause explosion, fire, and burn.
- Securely install the cover of control box and the panel.
  - If the cover and panel are not installed securely, dust or water may enter the outdoor unit and fire or electric shock may result.
- If the air conditioner is installed in a small room, measures must be taken to prevent the refrigerant concentration from exceeding the safety limit when the refrigerant leaks.
  - Consult the dealer regarding the appropriate measures to prevent the safety limit from being exceeded. Should the refrigerant leak and cause the safety limit to be exceeded, hazards due to lack of oxygen in the room could result.

### Operation

- Do not damage or use an unspecified power cord.
  - There is risk of fire, electric shock, explosion, or injury.
- Use a dedicated outlet for this appliance.
  - There is risk of fire or electrical shock.
- Be cautious that water could not enter the product.
  - There is risk of fire, electric shock, or product damage.
- Do not touch the power switch with wet hands.
  - There is risk of fire, electric shock, explosion, or injury.
- When the product is soaked (flooded or submerged), contact an Authorized Service Center.
  - There is risk of fire or electric shock.
- Be cautious not to touch the sharp edges when installing.
  - It may cause injury.
- Take care to ensure that nobody could step on or fall onto the outdoor unit.
  - This could result in personal injury and product damage.

- Do not open the inlet grille of the product during operation. (Do not touch the electrostatic filter, if the unit is so equipped.)
- There is risk of physical injury, electric shock, or product failure.

## CAUTION

### Installation

- Always check for gas (refrigerant) leakage after installation or repair of product.
    - Low refrigerant levels may cause failure of product.
  - Do not install the product where the noise or hot air from the outdoor unit could damage the neighborhoods.
    - It may cause a problem for your neighbors.
  - Keep level even when installing the product.
    - To avoid vibration or water leakage.
  - Do not install the unit where combustible gas may leak.
    - If the gas leaks and accumulates around the unit, an explosion may result.
  - Use power cables of sufficient current carrying capacity and rating.
    - Cables that are too small may leak, generate heat, and cause a fire.
  - Do not use the product for special purposes, such as preserving foods, works of art, etc. It is a consumer air conditioner, not a precision refrigeration system.
    - There is risk of damage or loss of property.
  - Keep the unit away from children. The heat exchanger is very sharp.
    - It can cause the injury, such as cutting the finger. Also the damaged fin may result in degradation of capacity.
  - When installing the unit in a hospital, communication station, or similar place, provide sufficient protection against noise.
    - The inverter equipment, private power generator, high-frequency medical equipment, or radio communication equipment may cause the air conditioner to operate erroneously, or fail to operate. On the other hand, the air conditioner may affect such equipment by creating noise that disturbs medical treatment or image broadcasting.
  - Do not install the product where it is exposed to sea wind (salt spray) directly.
    - It may cause corrosion on the product. Corrosion, particularly on the condenser and evaporator fins, could cause product malfunction or inefficient operation.
  - Do not install the unit in potentially explosive atmospheres.
- Turn on the power at least 6 hours before starting operation.
    - Starting operation immediately after turning on the main power switch can result in severe damage to internal parts. Keep the power switch turned on during the operational season.
  - Do not touch any of the refrigerant piping during and after operation.
    - It can cause a burn or frostbite.
  - Do not operate the air conditioner with the panels or guards removed.
    - Rotating, hot, or high-voltage parts can cause injuries.
  - Do not directly turn off the main power switch after stopping operation.
    - Wait at least 5 minutes before turning off the main power switch. Otherwise it may result in water leakage or other problems.
  - Auto-addressing should be done in condition of connecting the power of all indoor and outdoor units. Auto-addressing should also be done in case of changing the indoor unit PCB.
  - Use a firm stool or ladder when cleaning or maintaining the air conditioner.
    - Be careful and avoid personal injury.
  - Do not insert hands or other objects through the air inlet or outlet while the air conditioner is plugged in.
    - There are sharp and moving parts that could cause personal injury.

### Operation

- Do not use the air conditioner in special environments.
  - Oil, steam, sulfuric smoke, etc. can significantly reduce the performance of the air conditioner or damage its parts.
- Do not block the inlet or outlet.
  - It may cause failure of appliance or accident.
- Make the connections securely so that the outside force of the cable may not be applied to the terminals.
  - Inadequate connection and fastening may generate heat and cause a fire.
- Be sure the installation area does not deteriorate with age.
  - If the base collapses, the air conditioner could fall with it, causing property damage, product failure, or personal injury.
- Install and insulate the drain hose to ensure that water is drained away properly based on the installation manual.
  - A bad connection may cause water leakage.
- Be very careful about product transportation.
  - Only one person should not carry the product if it weighs more than 20 kg (44 lbs).
  - Some products use PP bands for packaging. Do not use any PP bands for a means of transportation. It is dangerous.
  - Do not touch the heat exchanger fins. Doing so may cut your fingers.
  - When transporting the outdoor unit, suspending it at the specified positions on the unit base. Also support the outdoor unit at four points so that it cannot slip sideways.
- Safely dispose of the packing materials.
  - Packing materials, such as nails and other metal or wooden parts, may cause stabs or other injuries.
  - Tear apart and throw away plastic packaging bags so that children may not play with them. If children play with a plastic bag which was not torn apart, they face the risk of suffocation.

## TABLE OF CONTENTS

<b>2</b>	<b>TIPS FOR SAVING ENERGY</b>	<b>51</b>	<b>INSTALLATION GUIDE AT THE SEASIDE</b>
<b>2</b>	<b>IMPORTANT SAFETY INSTRUCTIONS</b>	51	Model Designation
<b>5</b>	<b>INSTALLATION PROCESS</b>	51	Airborne Noise Emission
<b>5</b>	<b>OUTDOOR UNITS INFORMATION</b>		
<b>5</b>	<b>ALTERNATIVE REFRIGERANT R410A</b>		
<b>5</b>	<b>SELECT THE BEST LOCATION</b>		
<b>7</b>	<b>INSTALLATION SPACE</b>		
8	Air guide work		
<b>9</b>	<b>LIFTING METHOD</b>		
<b>9</b>	<b>INSTALLATION</b>		
9	The location of the Anchor bolts		
9	Foundation for Installation		
10	Preparation of Piping		
11	Plumbing materials and storage methods		
<b>12</b>	<b>REFRIGERANT PIPING INSTALLATION</b>		
12	Precautions on Pipe connection / Valve operation		
13	Installation procedure for HR unit		
13	Installation of Outdoor Unit, HR Unit, Indoor Unit Refrigerant Pipe		
13	Type of HR Unit		
14	Installation of Zoning Control		
15	Precautions on Pipe connection / Valve operation		
<b>17</b>	<b>PIPE CONNECTIONS BETWEEN INDOOR AND OUTDOOR UNIT</b>		
17	Preparation Work		
18	Pipe Drawing Out during Single connection		
18	Refrigerant piping system		
21	Preparation Work		
21	Pipe Drawing Out during Single connection		
22	Refrigerant piping system		
24	Refrigerant charging		
24	Branch pipe Fitting		
29	Distribution Method		
29	Vacuum Mode		
30	Leak Test and Vacuum drying		
31	Thermal insulation of refrigerant piping		
<b>32</b>	<b>ELECTRICAL WIRING</b>		
33	Control box and connecting position of wiring		
33	Communication and Power Cables		
34	Wiring of main power supply and equipment capacity		
34	Field Wiring		
36	Checking the setting of outdoor units		
37	Switch for setup of HR Unit		
41	Automatic Addressing		
41	The Procedure of Automatic Addressing		
42	Flow chart of auto pipe detection Process		
43	Flow chart of manual addressing for pipe detection		
43	Example of manual valve addressing (Non-Zoning setting)		
44	Example of manual valve addressing (Zoning setting)		
44	Method of checking the pipe detection result at HR unit		
44	Identification of Manual Valve ID (Address)		
44	Method of checking the pipe detection result at outdoor unit		
44	Setting method of Master indoor unit in zoning		
45	Group Number setting		
45	Cool & Heat selector (Fn 1)		
46	High Static Pressure Compensation mode (Fn 2)		
46	Night Low Noise Function (Fn 3)		
46	Setting the ODU address (Fn 5)		
47	Snow removal & rapid defrost (Fn 6)		
47	Target pressure adjusting (Fn 8)		
48	Self-Diagnosis Function		
<b>50</b>	<b>CAUTION FOR REFRIGERANT LEAK</b>		
50	Introduction		
50	Checking procedure of limiting concentration		

## INSTALLATION PROCESS

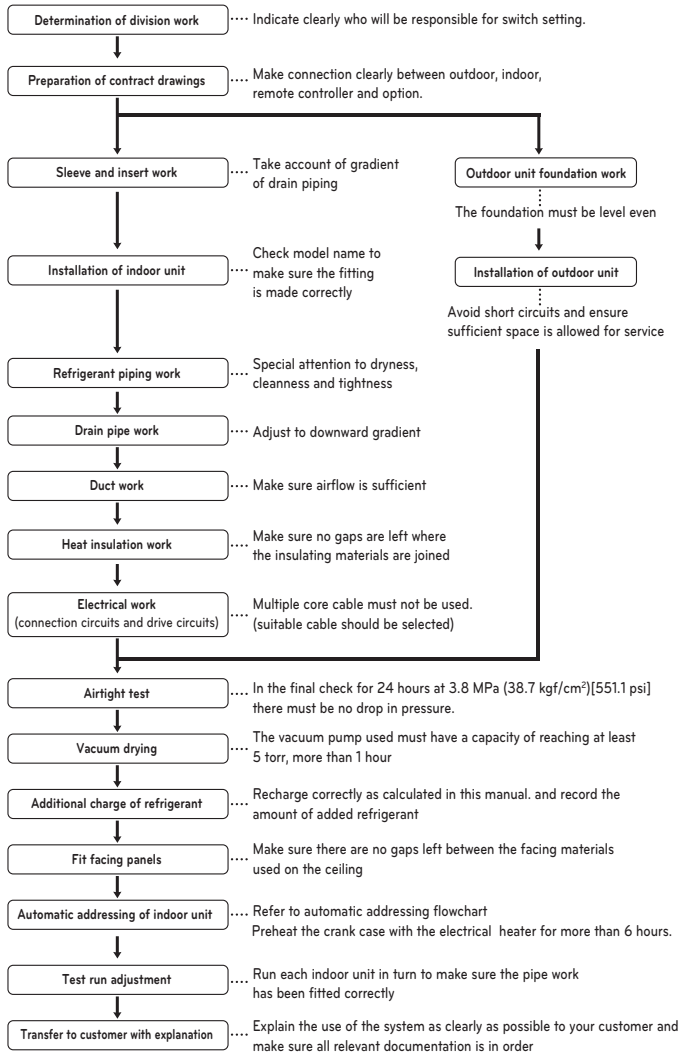

### CAUTION

- The above list indicates the order in which the individual work operations are normally carried out but this order may be varied where local conditions warrants such change.
- The thickness of the piping should comply with the relevant local and national regulations for the designed pressure 3.8 MPa (551.1 psi).
- Since R410A is a mixed refrigerant, the required additional refrigerant must be charged in its liquid state. (If the refrigerant is charged in its gaseous state, its composition changes and the system will not work properly.)

## OUTDOOR UNITS INFORMATION

### CAUTION

- Ratio of the connectable Indoor Units to the Outdoor: 50 ~ 130%
- Ratio of running Indoor Units to the Outdoor: 10 ~ 100%
- A combination operation over 100% cause to reduce each indoor unit capacity.

## ALTERNATIVE REFRIGERANT R410A

The refrigerant R410A has the property of higher operating pressure in comparison with R22.

Therefore, all materials have the characteristics of higher resisting pressure than R22 ones and this characteristic should also be considered during the installation.

R410A is an azeotrope of R32 and R125 mixed at 50:50, so the ozone depletion potential (ODP) of R410A is 0.

### CAUTION

- The wall thickness of the piping should comply with the relevant local and national regulations for the designed pressure 3.8 MPa [551.1 psi]
- Since R410A is a mixed refrigerant, the required additional refrigerant must be charged in its liquid state. If the refrigerant is charged in its gaseous state, its composition changes and the system will not work properly.
- Do not place the refrigerant container under the direct rays of the sun to prevent it from exploding.
- For high-pressure refrigerant, any unapproved pipe must not be used.
- Do not heat pipes more than necessary to prevent them from softening.
- Be careful not to install wrongly to minimize economic loss because it is expensive in comparison with R22.

## SELECT THE BEST LOCATION

Select space for installing outdoor unit, which will meet the following conditions:

- No direct thermal radiation from other heat sources
- No possibility of annoying neighbors due to noise of unit
- No exposition to strong wind
- With strength which bears weight of unit
- Note that drain flows out of unit when heating
- Because of the possibility of fire, do not install unit to the space where generation, inflow, stagnation, and leakage of combustible gas is expected.
- Avoid unit installation in a place where acidic solution and spray (sulfur) are often used.
- Do not use unit under any special environment where oil, steam and sulfuric gas exist.
- It is recommended to fence round the outdoor unit in order to prevent any person or animal from accessing the outdoor unit.
- If installation site is area of heavy snowfall, then the following directions should be observed.
  - Make the foundation as high as possible.
  - Fit a snow protection hood.
- Select installation location considering following conditions to avoid bad condition when additionally performing defrost operation.
  - Install the outdoor unit at a place well ventilated and having a lot of sunshine in case of installing the product at a place With a high humidity in winter (near beach, coast, lake, etc.) (Ex : Rooftop where there is always sunshine.)

When installing the outdoor unit in a place that is constantly exposed to a strong wind like a coast or on a high story of a building, secure a normal fan operation by using a duct or a wind shield.

- Install the unit so that its discharge port faces to the wall of the building.  
Keep a distance 500mm(19-11/16inch) or more between the unit and the wall surface.
- Supposing the wind direction during the operation season of the air conditioner, install the unit so that the discharge port is set at right angle to the wind direction.

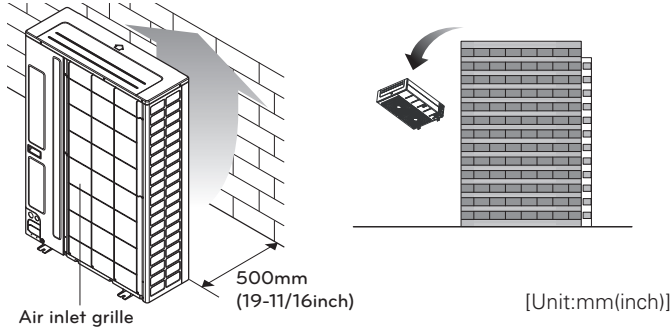

Turn the air outlet side toward the building's wall, fence or windbreak screen.

**WARNING**

Fix the outdoor unit firmly with anchor bolt or it may fall and hurt people. (refer to 'Foundation for installation')

**For Heat Recovery Installation**

Select installation location of the HR unit suitable for following conditions

- Avoid a place where rain may enter since the HR unit is for indoor.
- Sufficient service space must be obtained.
- Refrigerant pipe must not exceed limited length.
- Avoid a place subject to a strong radiation heat from other heat source.
- Avoid a place where oil spattering, vapor spray or high frequency electric noise is expected.
- Install the unit at a place in which it is not affected by operation noise. (Installation within cell such as meeting room etc. may disturb business due to noise.)
- Place where refrigerant piping, drain piping and electrical wiring works are easy.

**2 Series**

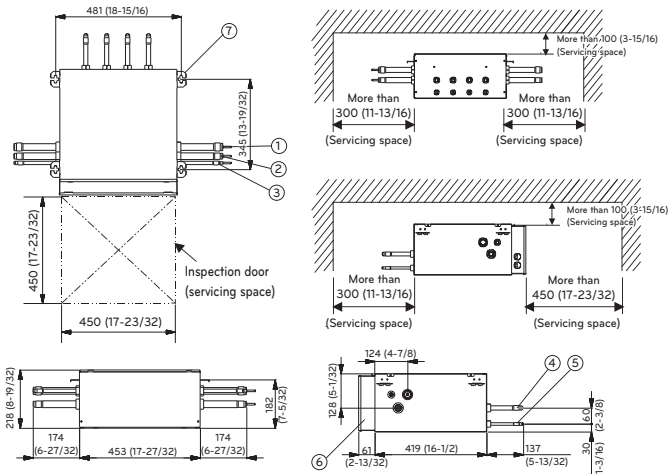

**3 Series**

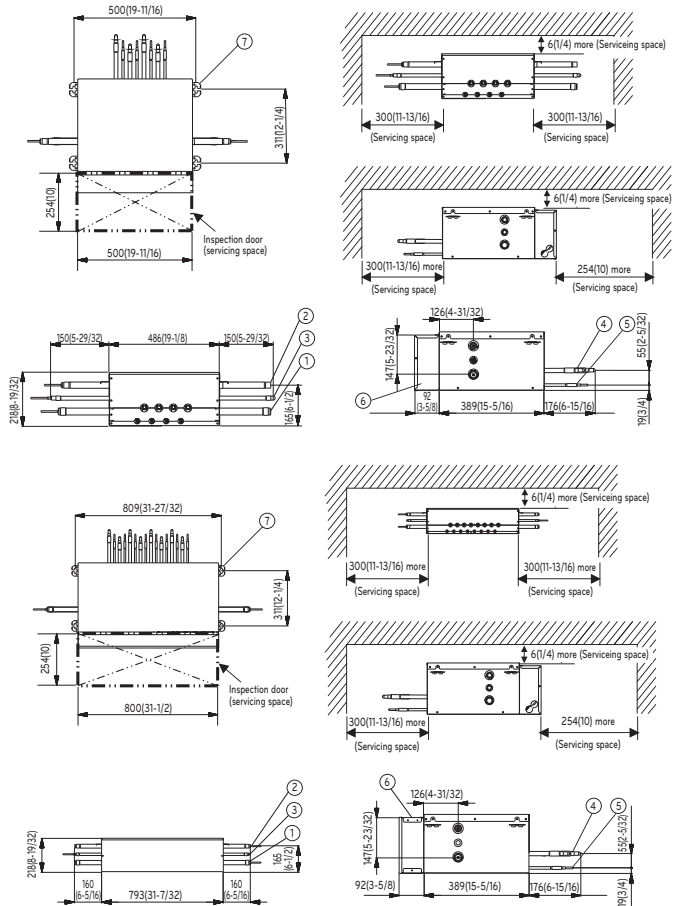

Unit: mm(inch)

No.	Part Name	Description	
		PRHR042A PRHR032A PRHR083A PRHR063A PRHR043A PRHR033A	PRHR022A PRHR023A
1	Low pressure Gas pipe connection port	Ø 28.58 (1-1/8) Brazing connection	Ø 22.2 (7/8) Brazing connection
2	High pressure Gas pipe connection port	Ø 22.2 (7/8) Brazing connection	Ø 19.05 (3/4) Brazing connection
3	Liquid pipe connection port	Ø 15.88 (5/8) Brazing connection (PRHR042A) Ø 12.7 (1/2) Brazing connection (PRHR032A)	Ø 9.52 (3/8) Brazing connection
4	Indoor unit Gas pipe connection port	Ø 15.88 (5/8) Brazing connection	Ø 15.88 (5/8) Brazing connection
5	Indoor unit Liquid pipe connection port	Ø 9.52 (3/8) Brazing connection	Ø 9.52 (3/8) Brazing connection
6	Control box	-	-
7	Hanger metal	M10 or M8	M10 or M8

**NOTE**

- Be sure to install the inspection door at the control box side.
- If reducers are used, servicing space must be increased equal to reducer's dimension.

# INSTALLATION SPACE

- The following values are the least space for installation. If any service area is needed for service according to field circumstance, obtain enough service space.
- The unit of values is mm.

## In case of obstacles on the suction side

### 1. Stand alone installation

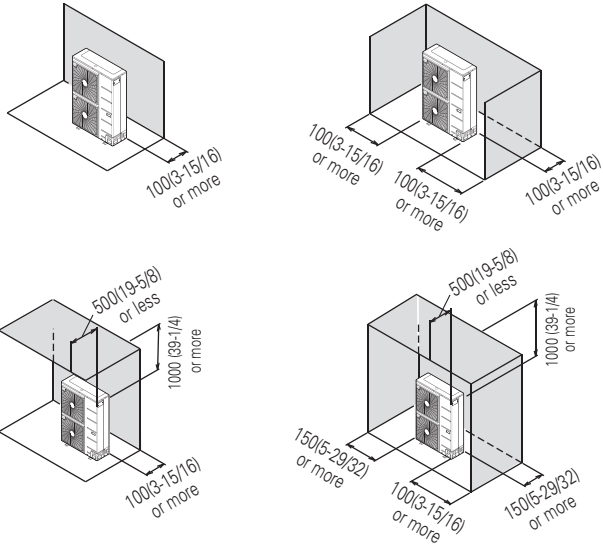

Unit:mm(inch)

### 2. Collective installation

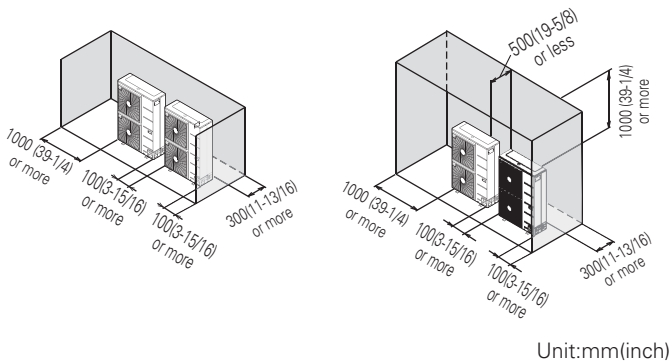

Unit:mm(inch)

## In case of obstacles on the discharge side

### 1. Stand alone installation

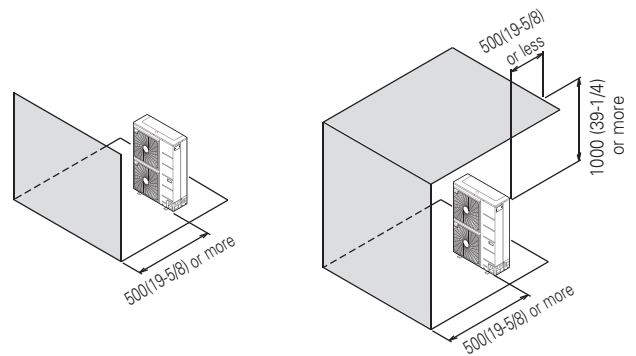

### 2. Collective installation

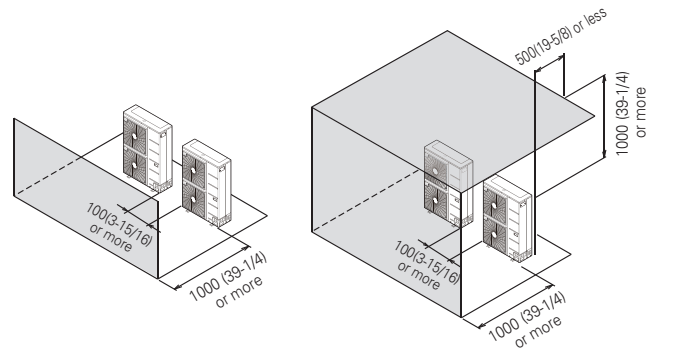

Unit:mm(inch)

## In case of obstacles on the suction and the discharge side

Obstacle height of discharge side is higher than the unit

### 1. Stand alone installation

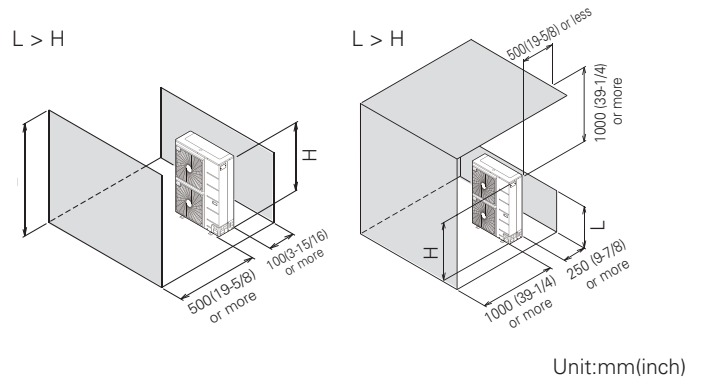

Unit:mm(inch)

### 2. Collective installation

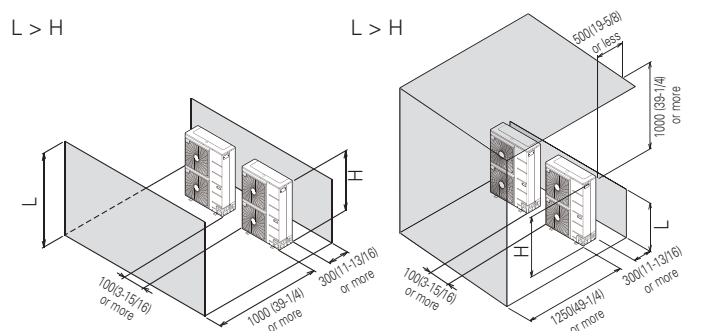

Unit:mm(inch)

## Obstacle height of discharge side is lower than the unit

### 1. Stand alone installation

$$L \leq H$$

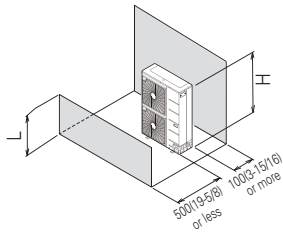

$$L \leq H$$

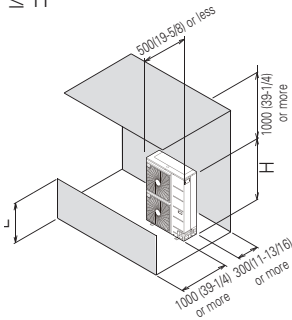

### 2. Collective installation

$$L \leq H$$

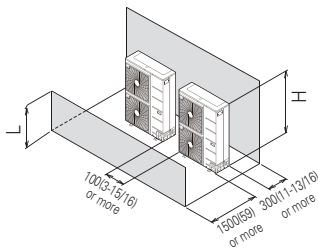

$$L \leq H$$

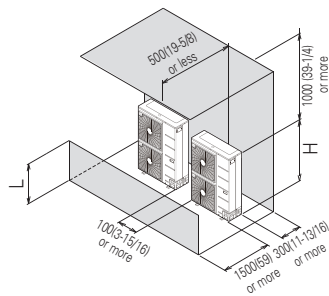

Unit:mm(inch)

### Seasonal wind and cautions in winter

- Sufficient measures are required in a snow areas or severe cold areas in winter so that product can be operated well.
- Get ready for seasonal wind or snow in winter even in other areas.
- Install a suction and discharge duct not to let in snow or rain.
- Install the outdoor unit in such a way that it should not come in contact with snow directly.  
If snow piles up and freezes on the air suction hole, the system may malfunction. If it is installed at snowy area, attach the hood to the system.
- The raised support platform must be high enough to allow the unit to remain above possible snow drifts, and must be higher than the maximum anticipated snowfall for the location.
- Where snow accumulated on the upper part of the Outdoor Unit by more than 10 cm (3.9 inch), always remove snow for operation.

- Don't install the suction hole and discharge hole of the Outdoor Unit facing the seasonal wind.

## Air guide work

In case of out door unit is located outdoor cabin of apartment or flats, then the efficiency can drop and system pressure increases thus finally damaging the compressor or other components in the system by heat short circuit.

- Do not use bended louver. It disturbs the air circulation.
- The opening ratio is at least 80%
- Louver angle is 0-20 degree
- Louver pitch will be as more than 100mm(3.9 inch)
- If you have a insect control net, consider the shielded area and static pressure loss
- Check the static pressure range of outdoor unit fan.  
Then, install air guide in the range of static pressure.

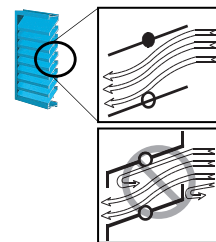
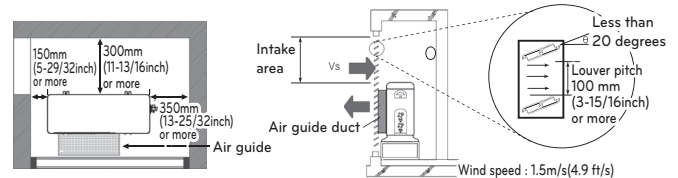

### Secure minimum intake area

When the intake area is not secured can efficiency drop and products may not be operating

- Minimum intake area (For reference)

Unit : m<sup>2</sup> (ft<sup>2</sup>)

System(Ton)	3, 4, 5
Minimum intake area	1.2(15.5)

## LIFTING METHOD

- When carrying the suspended, unit pass the ropes under the unit and use the two suspension points each at the front and rear.
- Always lift the unit with ropes attached at four points so that impact is not applied to the unit.
- Attach the ropes to the unit at an angle of 40° or less.

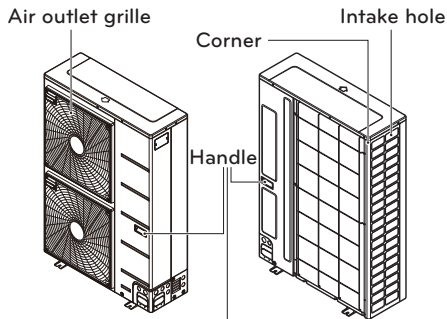

Always hold the unit by the corners, as holding it by the side intake holes on the casing may cause them to deform.

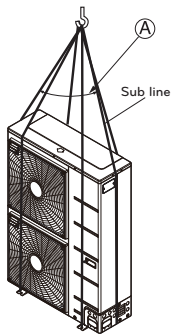

(A) 40° or less

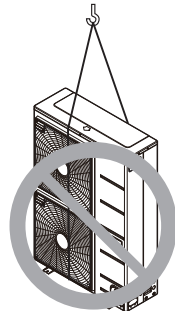

**WARNING**

## CAUTION

Be very careful while carrying the product.

- Do not have only one person carry product if it is more than 20 kg (44 lbs).
- PP bands are used to pack some products. Do not use them as a mean for transportation because they are dangerous.
- Do not touch heat exchanger fins with your bare hands. Otherwise you may get a cut in your hands.
- Tear plastic packaging bag and scrap it so that children cannot play with it. Otherwise plastic packaging bag may suffocate children to death.
- When carrying in Outdoor Unit, be sure to support it at four points. Carrying in and lifting with 3-point support may make Outdoor Unit unstable, resulting in a fall.
- Use 2 belts of at least 8 m (26.2 ft) long.
- Place extra cloth or boards in the locations where the casing comes in contact with the sling to prevent damage.
- Hoist the unit making sure it is being lifted at its center of gravity.

## INSTALLATION

- Install at places where it can endure the weight and vibration/noise of the outdoor unit.
- The outdoor unit support blocks at the bottom shall have width of at least 100 mm (3-15/16 inch) under the Unit's legs before being fixed.
- The outdoor unit support blocks should have minimum height of 200 mm (7-7/8 inch).
- Anchor bolts must be inserted at least 75 mm (2-15/16 inch).

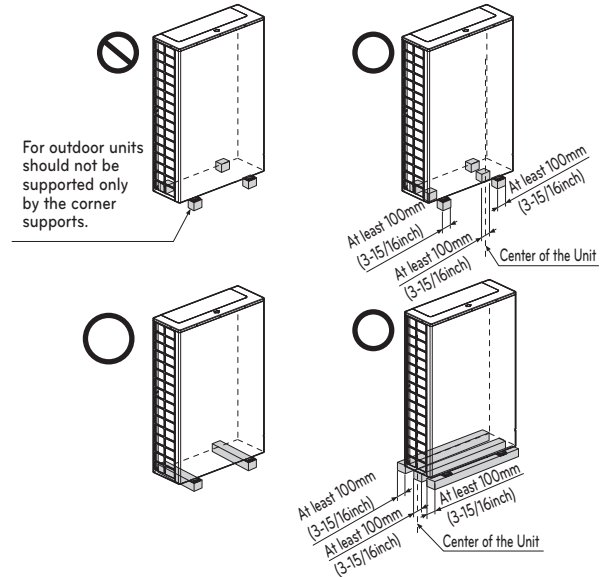

### The location of the Anchor bolts

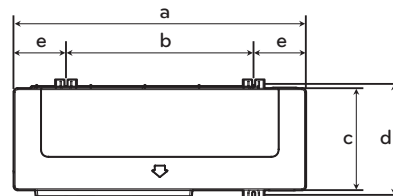

[Unit : mm(inch)]

System(Ton)	3, 4, 5
a	950(37-11/32)
b	619(24-11/32)
c	330(13)
d	360(14-3/16)
e	165.5(6-17/32)

### Foundation for Installation

- Fix the unit tightly with bolts as shown below so that unit will not fall down due to earthquake or gust.
- Use the H-beam support as a base support
- Noise and vibration may occur from the floor or wall since vibration is transferred through the installation part depending on installation status. Thus, use anti-vibration materials (cushion pad) fully (The base pad shall be more than 200 mm (7-7/8 inch)).

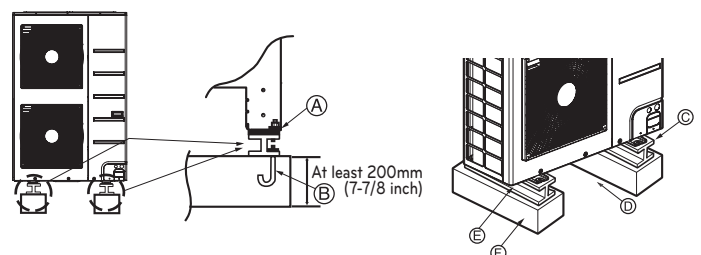

- Ⓐ The corner part must be fixed firmly. Otherwise, the support for the installation may be bent.
- Ⓑ Get and use M10 Anchor bolt.
- Ⓒ Put Cushion Pad between the outdoor unit and ground support for the vibration protection in wide area.
- Ⓓ Space for pipes and wiring (Pipes and wirings for bottom side)
- Ⓔ H-beam support
- Ⓕ Concrete support

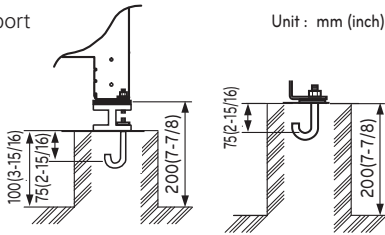

**WARNING**

- Install where it can sufficiently support the weight of the outdoor unit. If the support strength is not enough, the outdoor unit may drop and hurt people.
- Install where the outdoor unit may not fall in strong wind or earthquake. If there is a fault in the supporting conditions, the outdoor unit may fall and hurt people.
- Please take extra cautions on the supporting strength of the ground, water outlet treatment (treatment of the water flowing out of the outdoor unit in operation), and the passages of the pipe and wiring, when making the ground support.
- Do not use tube or pipe for water outlet in the Base panel. Use drainage instead for water outlet. The tube or pipe may freeze and the water may not be drained.

**CAUTION**

- Be sure to remove the Pallet (Wood Support) of the bottom side of the outdoor unit Base panel before fixing the bolt. It may cause the unstable state of the outdoor settlement, and may cause freezing of the heat exchanger resulting in abnormal operations.
- Be sure to remove the Pallet (Wood Support) of the bottom side of the outdoor unit before welding. Not removing Pallet (Wood Support) causes hazard of fire during welding.

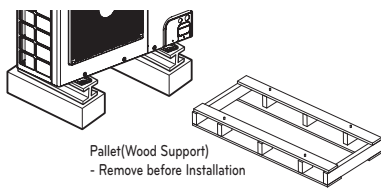

If it is necessary to prevent the unit from falling over, install as shown in the figure.

- Prepare all 4 wires as indicated in the drawing
- Unscrew the top plate at the 4 location indicated A and B
- Put the screws through the nooses and screw them back tight

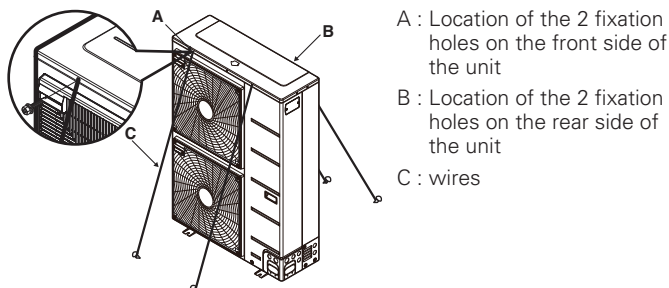

**Preparation of Piping**

Main cause of gas leakage is defect in flaring work. Carry out correct flaring work in the following procedure.

**Cut the pipes and the cable**

- Use the accessory piping kit or the pipes purchased locally.
- Measure the distance between the indoor and the outdoor unit.
- Cut the pipes a little longer than measured distance.
- Cut the cable 1.5 m (4.92 ft) longer than the pipe length.

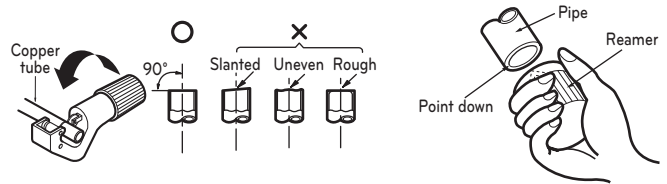

**Burrs removal**

- Completely remove all burrs from the cut cross section of pipe/tube.
- Put the end of the copper tube/pipe to downward direction as you remove burrs in order to avoid to let burrs drop in the tubing.

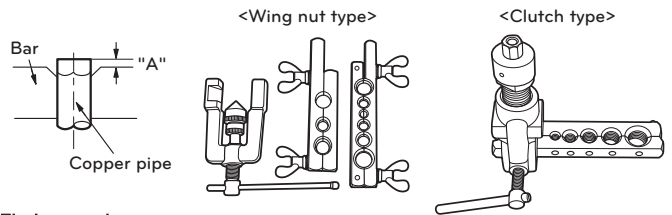

**Flaring work**

- Carry out flaring work using flaring tool as shown below.

Pipe diameter Inch (mm)	A inch (mm)	
	Wing nut type	Clutch type
Ø 1/4 (Ø 6.35)	0.04~0.05(1.1~1.3)	0~0.02 (0~0.5)
Ø 3/8 (Ø 9.52)	0.06~0.07(1.5~1.7)	
Ø 1/2 (Ø 12.7)	0.06~0.07(1.6~1.8)	
Ø 5/8 (Ø 15.88)	0.06~0.07(1.6~1.8)	
Ø 3/4 (Ø 19.05)	0.07~0.08(1.9~2.1)	

Firmly hold copper tube in a bar (or die) as indicated dimension in the table above.

**Check**

- Compare the flared work with figure below.
- If flare is noted to be defective, cut off the flared section and do flaring work again.

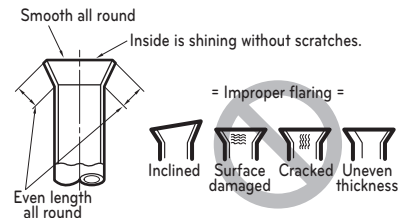

**Flare shape and flare nut tightening torque**

**Precautions when connecting pipes**

- See the following table for flare part machining dimensions.
- When connecting the flare nuts, apply refrigerant oil to the inside and outside of the flares and turn them three or four times at first. (Use ester oil or ether oil.)
- See the following table for tightening torque. (Applying too much torque may cause the flares to crack.)
- After all the piping has been connected, use nitrogen to perform a gas leak check.

Pipe size [mm (inch)]	A [mm (inch)]	Flare shape
Ø 9.52 (3/8)	12.8 (0.5)~13.2 (0.52)	
Ø 12.7 (1/2)	16.2 (0.64)~16.6 (0.65)	
Ø 15.88 (5/8)	19.3 (0.76)~19.7 (0.78)	

Piping Size		Torque		
mm	inch	kgf-cm	N-m	lbf-ft
Ø 6.35	Ø 1/4	180 ~ 250	17.6 ~ 24.5	13 ~ 18
Ø 9.52	Ø 3/8	340 ~ 420	33.3 ~ 41.2	25 ~ 30
Ø 15.88	Ø 5/8	630 ~ 820	61.7 ~ 80.4	45 ~ 59
Ø 12.7	Ø 1/2	550 ~ 660	53.9 ~ 64.7	40 ~ 48
Ø 19.05	Ø 3/4	990 ~ 1210	97.0 ~ 118.7	71 ~ 87

## CAUTION

- Always use a charge hose for service port connection.
- After tightening the cap, check that no refrigerant leaks are present.
- When loosening a flare nut, always use two wrenches in combination, When connecting the piping, always use a spanner and torque wrench in combination to tighten the flare nut.
- When connecting a flare nut, coat the flare(inner and outer faces) with oil for R410A(PVE) and hand tighten the nut 3 to 4 turns as the initial tightening.

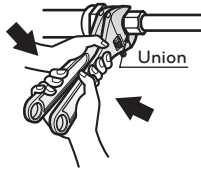

### Opening shutoff valve

- 1 Remove the cap and turn the valve counter clockwise with the hexagon wrench.
- 2 Turn it until the shaft stops.  
Do not apply excessive force to the shutoff valve. Doing so may break the valve body, as the valve is not a backseat type. Always use the special tool.
- 3 Make sure to tighten the cap securely.

### Closing shutoff valve

- 1 Remove the cap and turn the valve clockwise with the hexagon wrench.
- 2 Securely tighten the valve until the shaft contacts the main body seal.
- 3 Make sure to tighten the cap securely.  
\* For the tightening torque, refer to the table on the below.

### Tightening torque

Shut off valve size (mm (inch))	Tightening torque N·m (lbs·ft) (Turn clockwise to close)					
	Shaft (valve body)			Cap (Valve lid)	Service port	Gas line piping attached to unit
	Closed	Opened	Hexagonal wrench			
Ø 6.35 (1/4)	6.0±0.6 (4.4±0.4)	5.0±0.0 (3.7±0.4)	4 mm (0.16 inch)	17.6±2.0 (13.0±1.5)	12.7±2 (9.4±1.5)	-
Ø 9.52 (3/8)						
Ø 12.7 (1/2)	10.0±1.0 (7.4±0.7)	5.0±0.0 (3.7±0.4)	5 mm (0.24 inch)	20.0±2.0 (14.8±1.5)	12.7±2 (9.4±1.5)	-
Ø 15.88 (5/8)	12.0±1.2 (8.9±0.9)			25.0±2.5 (18.4±1.8)		
Ø 19.05 (3/4)	14.0±1.4 (10.3±1.0)	5.0±0.0 (3.7±0.4)	8 mm (0.31 inch)		25.0±2.5 (18.4±1.8)	12.7±2 (9.4±1.5)
Ø 22.2 (7/8)	30.0±3.0 (22.1±2.2)					
Ø 25.4 (1)						

### Insulation of shutoff valve

- 1 Use the heat insulation material for the refrigerant piping which has an excellent heat-resistance (over 120 °C [248 °F]).
- 2 Precautions in high humidity circumstance:  
This air conditioner has been tested according to the "ISO Conditions with Mist" and confirmed that there is not any default. However, if it is operated for a long time in high humid atmosphere (dew point temperature: More than 23 °C [73.4 °F]), water drops are liable to fall. In this case, add heat insulation material according to the following procedure:

- Heat insulation material to be prepared: EPDM (Ethylene Propylene Diene Methylene)-over 120 °C [248 °F] the heat-resistance temperature.
- Add the insulation over 10 mm [0.39 inch] thickness at high humidity environment.

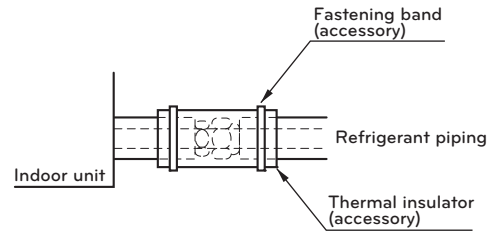

### Plumbing materials and storage methods

Pipe must be able to obtain the specified thickness and should be used with low impurities. Also when handling storage, pipe must be careful to prevent a fracture, deformity and wound. Should not be mixed with contaminations such as dust, moisture.

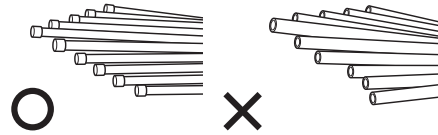

### Refrigerant piping on three principles

	Drying	Cleanliness	Airtight
	Should be no moisture inside	No dust inside.	There is no refrigerant leakage
Items			
Cause failure	<ul style="list-style-type: none"> <li>- Significant hydrolysis of refrigerant oil</li> <li>- Degradation of refrigerant oil</li> <li>- Poor insula'tion of the compressor</li> <li>- Do not cold and warm</li> <li>- Clogging of EEV, Capillary</li> </ul>	<ul style="list-style-type: none"> <li>- Degradation of refrigerant oil</li> <li>- Poor insulation of the compressor</li> <li>- Do not cold and warm</li> <li>- Clogging of EEV, Capillary</li> </ul>	<ul style="list-style-type: none"> <li>- Gas shortages</li> <li>- Degradation of refrigerant oil</li> <li>- Poor insulation of the compressor</li> <li>- Do not cold and warm</li> </ul>
Countermeasure	<ul style="list-style-type: none"> <li>- No moisture in the pipe</li> <li>- Until the connection is completed, the plumbing pipe entrance should be strictly controlled.</li> <li>- Stop plumbing at rainy day.</li> <li>- Pipe entrance should be taken side or bottom.</li> <li>- When removal burr after cutting pipe, pipe entrance should be taken down.</li> <li>- Pipe entrance should be fitted cap when pass through the walls.</li> </ul>	<ul style="list-style-type: none"> <li>- No dust in the pipe.</li> <li>- Until the connection is completed, the plumbing pipe entrance should be strictly controlled.</li> <li>- Pipe entrance should be taken side or bottom.</li> <li>- When removal burr after cutting pipe, pipe entrance should be taken down.</li> <li>- Pipe entrance should be fitted cap when pass through the walls.</li> </ul>	<ul style="list-style-type: none"> <li>- Airtightness test should be.</li> <li>- Brazing operations to comply with standards.</li> <li>- Flare to comply with standards.</li> <li>- Flange connections to comply with standards.</li> </ul>

## Nitrogen substitution method

Welding, as when heating without nitrogen substitution a large amount of the oxide film is formed on the internal piping.

The oxide film is caused by clogging EEV, Capillary, oil hole of accumulator and suction hole of oil pump in compressor.

It prevents normal operation of the compressor.

In order to avoid this problem, Welding should be done after replacing air by nitrogen gas.

When welding plumbing pipe, the work is required.

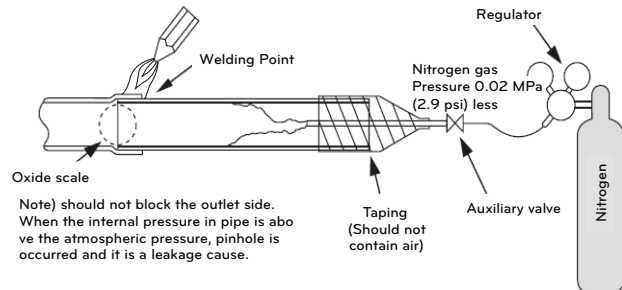

### CAUTION

- Always use the nitrogen.(not use oxygen, carbon dioxide, and a Chevron gas): Please use the following nitrogen pressure 0.02 MPa (2.9 psi) Oxygen - Promotes oxidative degradation of refrigerant oil. Because it is flammable, it is strictly prohibited to use Carbon dioxide - Degrade the drying characteristics of gas Chevron Gas - Toxic gas occurs when exposed to direct flame.
- Always use a pressure reducing valve.
- Please do not use commercially available antioxidant. The residual material seems to be the oxide scale is observed. In fact, due to the organic acids generated by oxidation of the alcohol contained in the anti-oxidants, ants nest corrosion occurs. (causes of organic acid → alcohol + copper + water + temperature)

## REFRIGERANT PIPING INSTALLATION

### For Heat Recovery System Installation

#### Precautions on Pipe connection / Valve operation

Pipe connection is done by connecting from the end of the pipe to the branching pipes, and the refrigerant pipe coming out of the outdoor unit is divided at the end to connect to each indoor unit. Flare connection for the indoor unit, and welding connection for the outdoor pipe and the branching parts. (Including HR Unit)

\* Pipes and wires should be purchased separately for installation of the product.

- Use hexagonal wrench to open/close the valve.

### ARUB\*\*\*GSS4

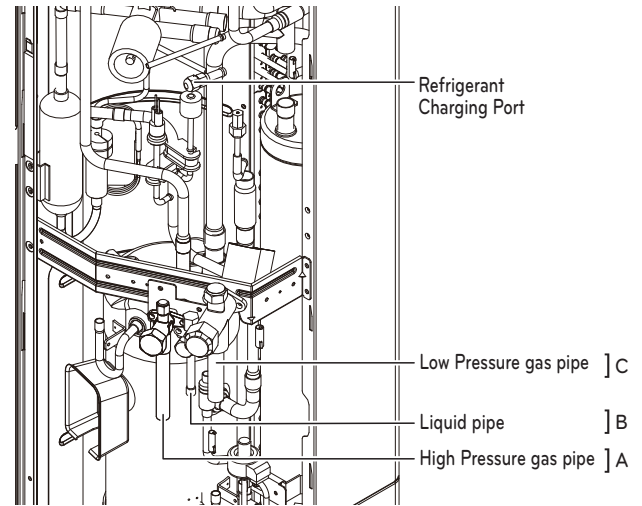

- Refer to the table below and install with the correct pipe diameter.

	Heat Recovery	Heat Pump
A[mm(inch)]	Ø15.88(5/8)	-
B[mm(inch)]	Ø9.52(3/8)	-
C[mm(inch)]	Ø19.05(3/4)	-

### ARUM\*\*\*GSS5

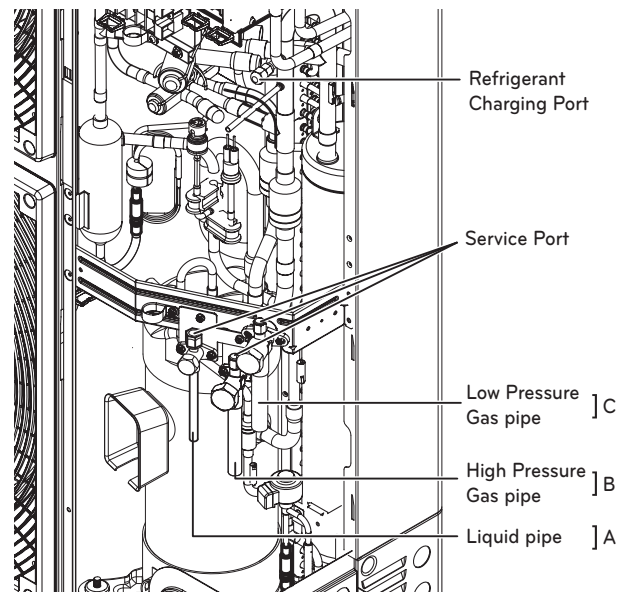

- Refer to the table below and install with the correct pipe diameter.

	Heat Recovery	Heat Pump
A[mm(inch)]	Ø9.52(3/8)	Ø9.52(3/8)
B[mm(inch)]	Ø15.88(5/8)	Ø15.88(5/8)
C[mm(inch)]	Ø19.05(3/4)	Not Used*

\* In case of heat pump installation, please weld with the proper Low pressure Gas pipe included with product.

## ⚠ WARNING

- Always careful not to leak the refrigerant during welding.
- The refrigerant generates poisonous gas harmful to human body if combusted.
- Do not perform welding in a closed space.
- Be sure to close the cap of the service port to prevent gas leakage after the work.

## ⚠ CAUTION

Please block the pipe knock outs of the front and side panels after installing the pipes.  
(Animals or foreign objects may be brought in to damage wires.)

## Installation procedure for HR unit

- 1 Using an insert-hole-in- anchor, hang the hanging bolt.
- 2 Install a hexagon nut and a flat washer (locally-procured)to the hanging bolt as shown in the figure in the bottom, and fit the main unit to hang on the hanger metal.
- 3 After checking with a level that the unit is level, tighten the hexagon nut.  
\* The tilt of the unit should be within  $\pm 5^\circ$  in front/back and left/right.
- 4 This unit should be installed suspended from ceiling and side A should always be facing up.
- 5 Insulate not used pipes completely as shown in the figure.

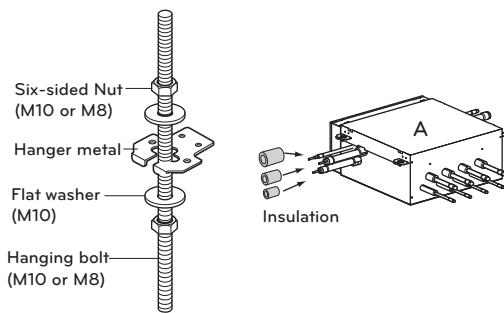

## Installation of Outdoor Unit, HR Unit, Indoor Unit Refrigerant Pipe

3 pipes are connected to the HR unit from the outdoor unit, classified into liquid pipe, low pressure gas pipe and high pressure gas pipe depending on status of refrigerant passing through the pipe.

You must connect 3 pipes from outdoor unit to HR unit.

For connection between indoor unit and HR unit, you must connect both liquid pipe and gas pipe from the HR unit to the indoor unit. In this case, connect them to the indoor unit starting from No.1 connection port of the HR unit (the port number is displayed on ports of the HR unit). Use auxiliary flare as annexed parts in connection to the indoor unit.

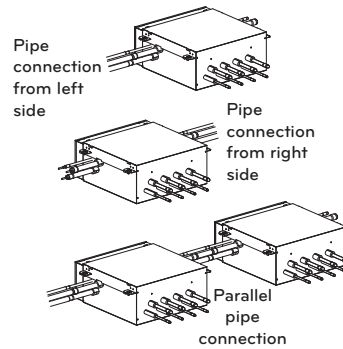
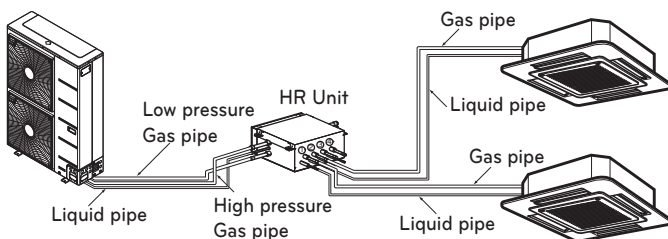

## ⚠ CAUTION

Whenever connecting the indoor units with the HR unit, install the indoor units in numerical order from No.1.

Ex) In case of installing 3 indoor units : No. 1, 2, 3 (O), No. 1, 2, 4 (X), No.1, 3, 4 (X), No.2, 3, 4 (X).

## ⚠ WARNING

Before brazing work, remove gas in the HR Unit by cutting the three pipes in the small circles on the figure.  
If not, it may cause injuries.  
Remove the caps before connecting pipes.

## Type of HR Unit

Select an HR unit according to the number of the indoor units to be installed. HR units are classified into 3 types by the number of connectable indoor units.

Ex) Installation of 6 indoor units

Consists of HR unit for 4 branches and HR unit for 2 branches.

### 2 Series

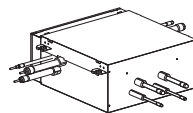

PRHR022A  
(2 branches)

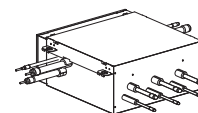

PRHR032A  
(3 branches)

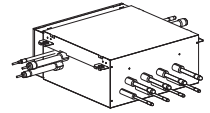

PRHR042A  
(4 branches)

### 3 Series

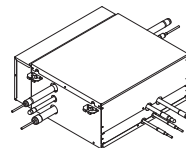

PRHR023A  
(2 branches)

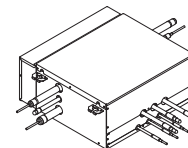

PRHR033A  
(3 branches)

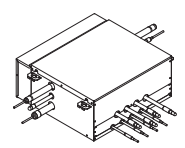

PRHR043A  
(4 branches)

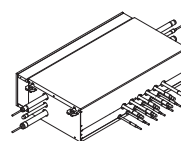

PRHR063A  
(6 branches)

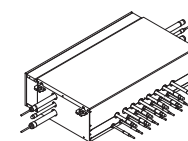

PRHR083A  
(8 branches)

### Joint Method of HR Unit (Big Duct : ARNU763B8-, ARNU963B8-)

Joint Method is required when the big duct chassis is installed. In Joint Method, two neighboring outlets of one HR unit are linked by Y branch pipe and connected to one indoor unit.

#### 2 Series

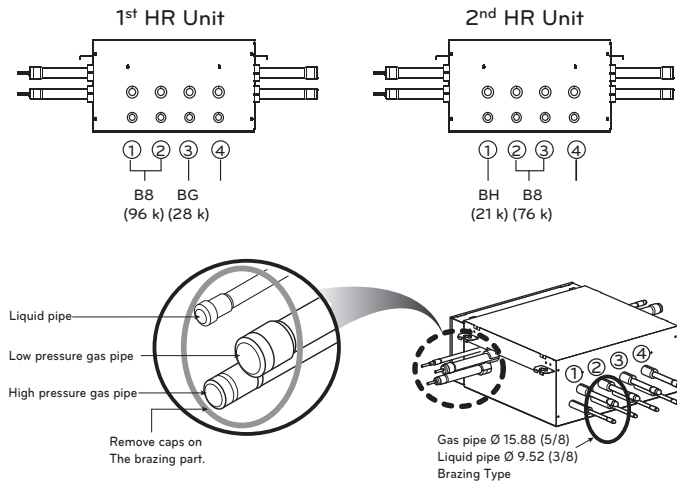

#### 3 Series

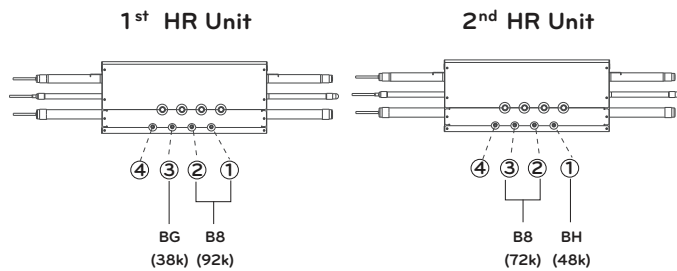

#### NOTE

- A connection to un-neighboring pipes is forbidden. Do not link more than 2 outlets.

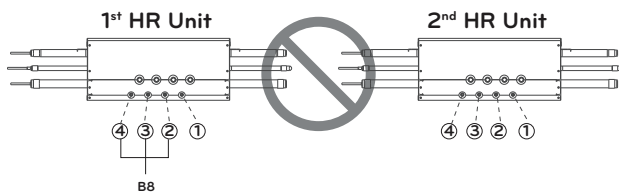
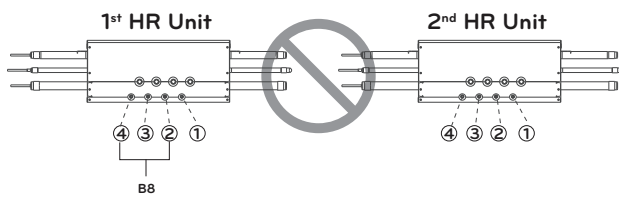

- The B8 unit, which has the largest capacity, must be connected to the 1st and 2nd outlets of the 1st HR unit. Other B8 units can be connected to any two neighboring outlets within one HR unit.

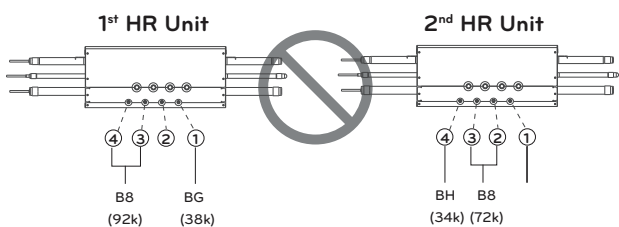

HR unit	PRHR022A PRHR023A	PRHR032A PRHR033A	PRHR042A PRHR043A PRHR063A PRHR083A
Low pressure gas pipe	Ø 22.2 (7/8)	Ø 28.58 (1-1/8)	Ø 28.58 (1-1/8)
High pressure gas pipe	Ø 19.05 (3/4)	Ø 22.2 (7/8)	Ø 22.2 (7/8)
Liquid pipe	Ø 9.52 (3/8)	Ø 12.7 (1/2)	Ø 15.88 (5/8)

### Installation of Zoning Control

Some indoor unit can be connected to one port of HR unit.

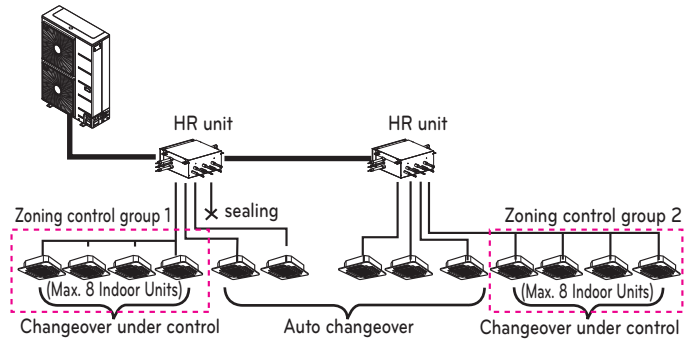

### WARNING

- A branch pipe of HR unit allows up to 14.5kW(48kBtu/h) based on cooling capacity of the indoor unit. (up to 14.5kW(48kBtu/h) for max installation)
- The maximum total capacity of indoor units connected to a PRHR043(A) HR unit is 58kW(192kBtu/h).
- The maximum number of indoor units connected to a PRHR043(A) HR unit are 32 indoor units. (The Maximum indoor units per a branch pipe of HR unit are 8 indoor units)
- There is not operate "Auto-changeover" & "Mode override" function in the zoning group.
- When there are operating indoor units on cooling(heating) mode, another indoor units aren't changed on heating(cooling) mode in the zoning group.
- For detailed instructions on installing the HR Unit, see the installation manual included with the HR Unit.

#### [Reducers for indoor unit and HR unit]

\* For more information, refer accessory installation manual.

Unit : mm (inch)

Models	Liquid pipe	Gas pipe	
		High pressure	Low pressure
Indoor unit reducer	 OD 9.52(3/8) Ø 6.35(1/4)	-	 OD 15.88(5/8) Ø 12.7(1/2)
HR unit reducer	 OD 9.52(3/8) Ø 6.35(1/4)	 OD 19.05(3/4) Ø 15.88(5/8) Ø 12.7(1/2)	 OD 22.2(7/8) Ø 19.05(3/4) Ø 15.88(5/8)
		 OD 12.7(1/2) Ø 9.52(3/8)	 OD 15.88(5/8) Ø 12.7(1/2)
HR unit reducer	 OD 15.88(5/8) Ø 12.7(1/2) Ø 9.52(3/8)	 OD 22.2(7/8) Ø 19.05(3/4) Ø 15.88(5/8)	 OD 28.58(1-1/8) Ø 22.2(7/8) Ø 19.05(3/4)
		 OD 12.7(1/2) Ø 9.52(3/8)	 OD 15.88(5/8) Ø 12.7(1/2)
		 OD 15.88(5/8) Ø 12.7(1/2)	 OD 19.05(3/4) Ø 15.88(5/8)
		 OD 12.7(1/2) Ø 9.52(3/8)	 OD 15.88(5/8) Ø 12.7(1/2)

## Caution

- Use the following materials for refrigerant piping.
  - Material: Seamless phosphorous deoxidized copper pipe
  - Wall thickness : Comply with the relevant local and national regulations for the designed pressure 3.8 MPa (551 psi). We recommend the following table as the minimum wall thickness.

Outer diameter [mm(inch)]	6.35 (1/4)	9.52 (3/8)	12.7 (1/2)	15.88 (5/8)	19.05 (3/4)	22.2 (7/8)	25.4 (1)	28.58 (1-1/8)	31.8 (1-1/4)	34.9 (1-3/8)	38.1 (1-1/2)	41.3 (1-5/8)	44.45 (1-3/4)	53.98 (2-1/8)
Minimum thickness [mm(inch)]	0.8 (0.03)	0.8 (0.03)	0.8 (0.03)	0.99 (0.04)	0.99 (0.04)	0.99 (0.04)	0.99 (0.04)	0.99 (0.04)	1.1 (0.04)	1.21 (0.05)	1.35 (0.05)	1.43 (0.06)	1.55 (0.06)	2.1 (0.08)

- Commercially available piping often contains dust and other materials. Always blow it clean with a dry inert gas.
- Use care to prevent dust, water or other contaminants from entering the piping during installation.
- Reduce the number of bending portions as much as possible, and make bending radius as big as possible.
- Always use the branch piping set shown below, which are sold separately.

Y branch	Header		
	4 branches	7 branches	10 branches
ARBLB01621, ARBLB03321, ARBLB07121, ARBLB14521, ARBLB23220	ARBL054	ARBL057	ARBL1010
	ARBL104	ARBL107	ARBL2010

- If the diameters of the branch piping of the designated refrigerant piping differs, use a pipe cutter to cut the connecting section and then use an adapter for connecting different diameters to connect the piping.
- Always observe the restrictions on the refrigerant piping (such as rated length, difference in height, and piping diameter). Failure to do so can result in equipment failure or a decline in heating/cooling performance.
- A second branch cannot be made after a header. (These are shown by .)

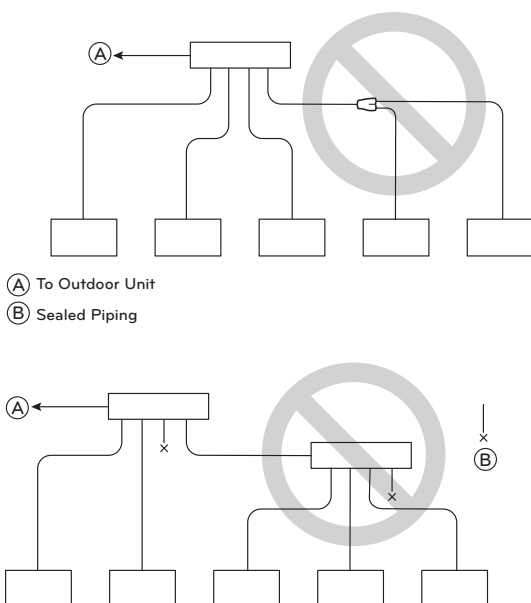

- The Multi V will stop due to an abnormality like excessive or insufficient refrigerant. At such a time, always properly charge the unit. When servicing, always check the notes concerning both the piping length and the amount of additional refrigerant.
- Never perform a pump down. This will not only damage the compressor but also deteriorate the performance.
- Never use refrigerant to perform an air purge. Always evacuate air by using a vacuum pump.

- Always insulate the piping properly. Insufficient insulation will result in a decline in heating/cooling performance, drip of condensate and other such problems.
- When connecting the refrigerant piping, make sure the service valves of the Outdoor Unit is completely closed (the factory setting) and do not operate it until the refrigerant piping for the Outdoor and Indoor Units has been connected, a refrigerant leakage test has been performed and the evacuation process has been completed.
- Always use a non-oxidizing brazing material for brazing the parts and do not use flux. If not, oxidized film can cause clogging or damage to the compressor unit and flux can harm the copper piping or refrigerant oil.

## ! WARNING

**When installing and moving the air conditioner to another site, be sure to make recharge refrigerant after perfect evacuation.**

- If a different refrigerant or air is mixed with the original refrigerant, the refrigerant cycle may malfunction and the unit may be damaged.
- After selecting diameter of the refrigerant pipe to suit total capacity of the indoor unit connected after branching, use an appropriate branch pipe set according to the pipe diameter of the indoor unit and the installation pipe drawing.

## For Heat Pump System Installation

### Precautions on Pipe connection / Valve operation

Pipe connection is done by connecting from the end of the pipe to the branching pipes, and the refrigerant pipe coming out of the outdoor unit is divided at the end to connect to each indoor unit. Flare connection for the indoor unit, and welding connection for the outdoor pipe and the branching parts.

\* Pipes and wires should be purchased separately for installation of the product.

- Use hexagonal wrench to open/close the valve.

\* In case of the heat pump system installation, be sure to maintain to close no use pipe like below picture.

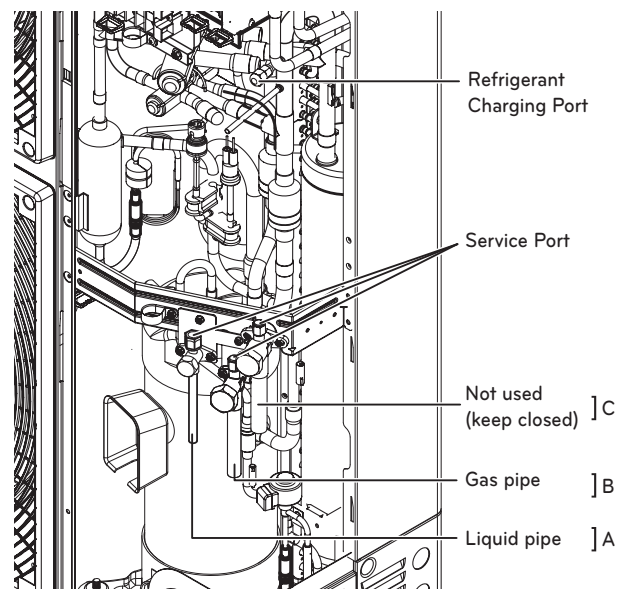

- Refer to the table below and install with the correct pipe diameter.

	Heat Recovery	Heat Pump
A[mm(inch)]	Ø9.52(3/8)	Ø9.52(3/8)
B[mm(inch)]	Ø15.88(5/8)	Ø15.88(5/8)
C[mm(inch)]	Ø19.05(3/4)	Not Used*

\* In case of heat pump installation, please weld with the proper Low pressure Gas pipe included with product.

**! WARNING**

- Always careful not to leak the refrigerant during welding.
- The refrigerant generates poisonous gas harmful to human body if combusted.
- Do not perform welding in a closed space.
- Be sure to close the cap of the service port to prevent gas leakage after the work.

**! CAUTION**

Please block the pipe knock outs of the front and side panels after installing the pipes.  
(Animals or foreign objects may be brought in to damage wires.)

**Caution**

- 1 Use the following materials for refrigerant piping.
  - Material: Seamless phosphorous deoxidized copper pipe
  - Wall thickness : Comply with the relevant local and national regulations for the designed pressure 3.8 MPa (551 psi). We recommend the following table as the minimum wall thickness.

Outer diameter [mm(inch)]	6.35 (1/4)	9.52 (3/8)	12.7 (1/2)	15.88 (5/8)	19.05 (3/4)	22.2 (7/8)	25.4 (1)	28.58 (1-1/8)	31.8 (1-1/4)	34.9 (1-3/8)	38.1 (1-1/2)	41.3 (1-5/8)	44.45 (1-3/4)	53.98 (2-1/8)
Minimum thickness [mm(inch)]	0.8 (0.03)	0.8 (0.03)	0.8 (0.03)	0.99 (0.04)	0.99 (0.04)	0.99 (0.04)	0.99 (0.04)	0.99 (0.04)	1.1 (0.04)	1.21 (0.05)	1.35 (0.05)	1.43 (0.06)	1.55 (0.06)	2.1 (0.08)

- 2 Commercially available piping often contains dust and other materials. Always blow it clean with a dry inert gas.
- 3 Use care to prevent dust, water or other contaminants from entering the piping during installation.
- 4 Reduce the number of bending portions as much as possible, and make bending radius as big as possible.
- 5 Always use the branch piping set shown below, which are sold separately.

Y branch	Header		
	4 branches	7 branches	10 branches
ARBLN01621, ARBLN03321, ARBLN07121, ARBLN14521, ARBLN23220	ARBL054	ARBL057	ARBL1010
	ARBL104	ARBL107	ARBL2010

- 6 If the diameters of the branch piping of the designated refrigerant piping differs, use a pipe cutter to cut the connecting section and then use an adapter for connecting different diameters to connect the piping.
- 7 Always observe the restrictions on the refrigerant piping (such as rated length, difference in height, and piping diameter). Failure to do so can result in equipment failure or a decline in heating/cooling performance.
- 8 A second branch cannot be made after a header. (These are shown by ⊗.)

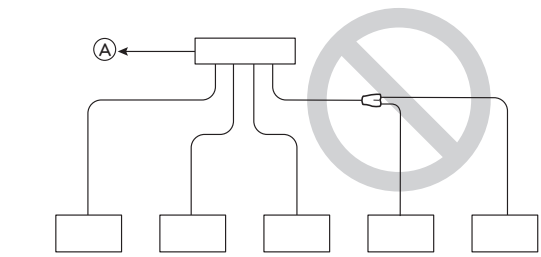

Ⓐ To Outdoor Unit  
Ⓑ Sealed Piping

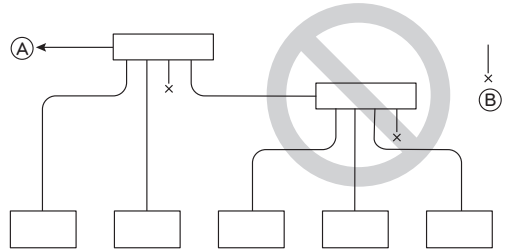

- 9 The Multi V will stop due to an abnormality like excessive or insufficient refrigerant. At such a time, always properly charge the unit. When servicing, always check the notes concerning both the piping length and the amount of additional refrigerant.
- 10 Never perform a pump down. This will not only damage the compressor but also deteriorate the performance.
- 11 Never use refrigerant to perform an air purge. Always evacuate air by using a vacuum pump.
- 12 Always insulate the piping properly. Insufficient insulation will result in a decline in heating/cooling performance, drip of condensate and other such problems.
- 13 When connecting the refrigerant piping, make sure the service valves of the Outdoor Unit is completely closed (the factory setting) and do not operate it until the refrigerant piping for the Outdoor and Indoor Units has been connected, a refrigerant leakage test has been performed and the evacuation process has been completed.
- 14 Always use a non-oxidizing brazing material for brazing the parts and do not use flux. If not, oxidized film can cause clogging or damage to the compressor unit and flux can harm the copper piping or refrigerant oil.

**! WARNING**

**When installing and moving the air conditioner to another site, be sure to make recharge refrigerant after perfect evacuation.**

- If a different refrigerant or air is mixed with the original refrigerant, the refrigerant cycle may malfunction and the unit may be damaged.
- After selecting diameter of the refrigerant pipe to suit total capacity of the indoor unit connected after branching, use an appropriate branch pipe set according to the pipe diameter of the indoor unit and the installation pipe drawing.

## PIPE CONNECTIONS BETWEEN INDOOR AND OUTDOOR UNIT

- Pipe connections can be done on the front side or on the side according to the installation environments.
- Be sure to let 0.2 kgf/cm<sup>2</sup> (2.8 psi) Nitrogen flow in the pipe when welding.
- If Nitrogen was not flown during welding, many oxidized membranes may form inside the pipe and disturb the normal operations of valves and condensers.

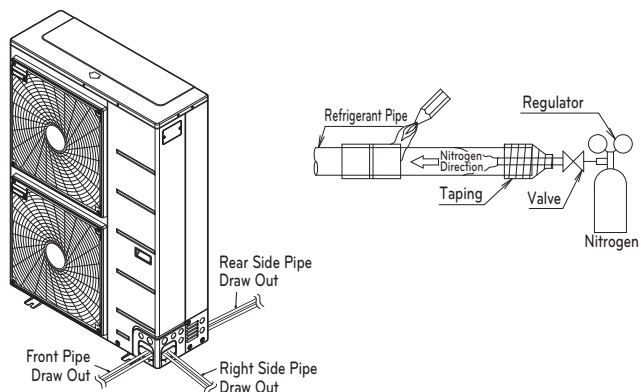

### For Heat Recovery System Installation

#### Preparation Work

- Use Knock Outs of Cover of the outdoor unit for Front/Right or Rear pipe drawing outs.

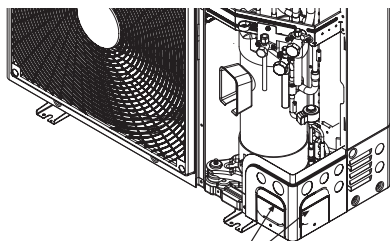

Removal Area for Liquid/Gas pipe bottom side connections.

- Use the wet towel as shown in the below figure before welding

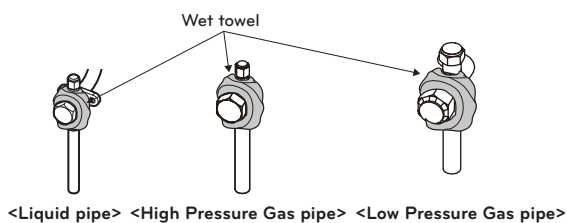

#### CAUTION

- Do not give damage to the pipe/base during the Knock Out work.
- Proceed to pipe work after removing burr after Knock Out work.
- Perform sleeve work to prevent damage to the wire when connecting wires using Knock Outs.

#### Remove leakage prevention cap

- Remove the leakage prevention cap attached to the outdoor unit service valve before pipe work.
- Proceed the leakage prevention cap removal as follows:
  - Verify whether the liquid/gas pipes are locked.
  - Extract remaining refrigerant or air inside using the service port.
  - Remove the leakage prevention cap

#### ARUB\*\*\*GSS4

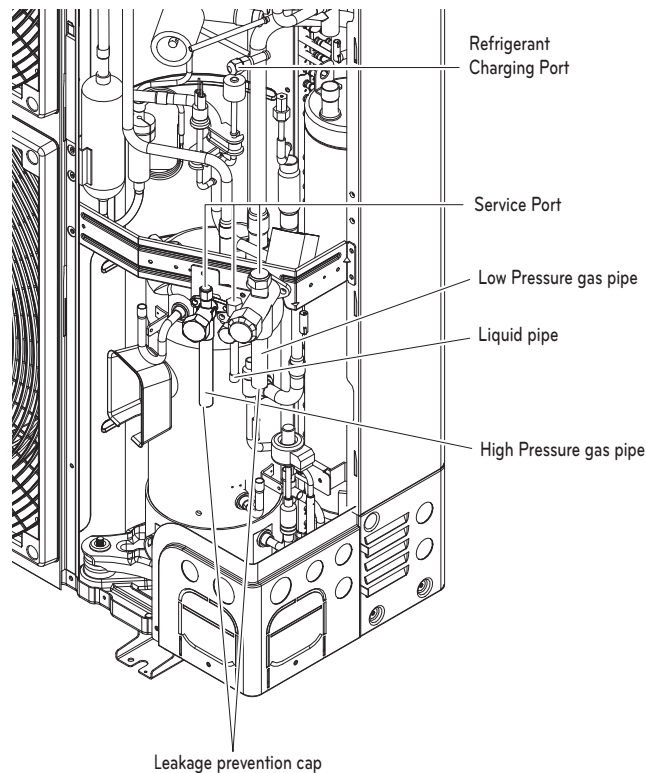

#### ARUM\*\*\*GSS5

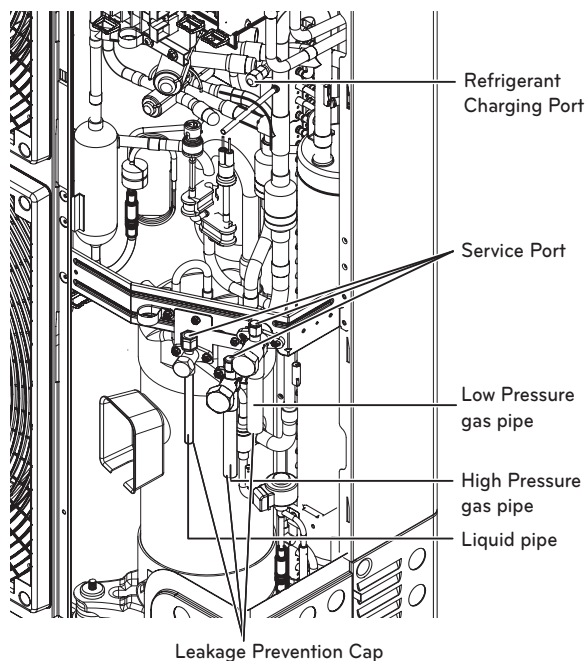

## Pipe Drawing Out during Single connection

### Method of drawing out pipes on the front side and right side

- Proceed with the pipe work as shown in the below figure for front side and right side pipe drawing out.

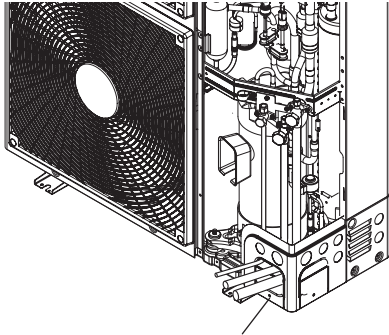

Pipe Knock Out for Liquid/Gas pipes

### Method of drawing out pipes on the rear side

- Proceed with the pipe work as shown in the below figure for rear side pipe drawing out.

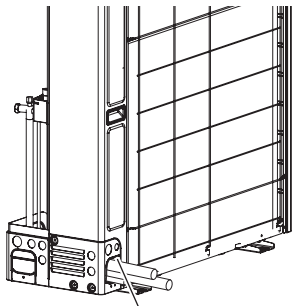

Pipe Knock Out for Liquid/Gas pipes

\* Pictures may differ depending on the model.

## Refrigerant piping system

### Refrigerant Pipe Connection

Example : 12 Indoor Units connected

- Ⓐ : Outdoor Unit
- Ⓑ : Y branch
- Ⓓ : Indoor Unit
- Ⓒ : Header
- Ⓗ : HR Unit

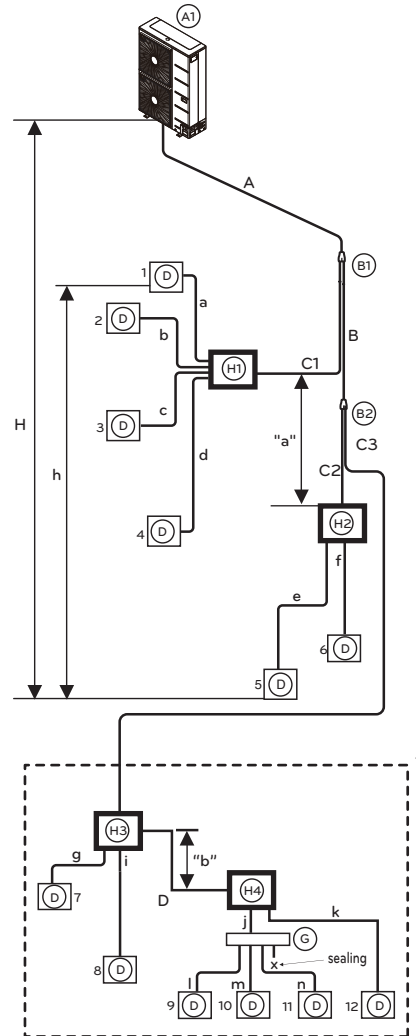

■ Case 1 ("a")

: Maximum height is 15m(49ft) if you install with Y branch.

■ Case 2 ("b")

: Maximum height is 5m(16ft) in serial connection of HR units.

### ! WARNING

- Refer to the HR unit PCB part for the valve group control setting.
- It is recommended that difference in pipe lengths between an HR unit and indoor units, for example difference in length of a, b, c, and d, be minimized. The larger difference in pipe lengths, the more different performance between indoor units.

\* If the large capacity indoor units (Over 5 HP; using over  $\varnothing 15.88(5/8)/9.52(3/8)$ ) are installed, it should be used the Valve Group setting

## Refrigerant pipe diameter from outdoor unit to first branch. (A)

Upward outdoor unit total capacity	Pipe diameter		
	Liquid mm(inch)	Low pressure gas pipe mm(inch)	High pressure gas pipe mm(inch)
Ton			
3,4,5	Ø9.52 (3/8)	Ø19.05 (3/4)	Ø15.88 (5/8)

\* If available on site, it use this size. Otherwise it can't be increased.

## Refrigerant pipe diameter from branch to branch (B,C,D)

Downward Indoor Unit total capacity [kW(Btu/h)]	Liquid pipe [mm(inch)]	Gas pipe [mm(inch)]
≤ 5.6(19,100)	Ø6.35(1/4)	Ø12.7(1/2)
< 16.0(54,600)	Ø9.52(3/8)	Ø15.88(5/8)
≤ 22.4(76,400)	Ø9.52(3/8)	Ø19.05(3/4)
< 36.4(124,200)	Ø9.52(3/8)	Ø22.2(7/8)

Total pipe length = A+B+C1+C2+C3+D+a+b+c+d+e+f+g+i+j+k+l+m+n  
 ≤ 300m(984ft)

L	Longest pipe length	*Equivalent pipe length
	A+B+C3+D+k ≤ 150m(492ft)	A+B+C3+D+k ≤ 175m(574ft)
l	Longest pipe length after 1st branch	
	B+C+D+e ≤ 40m(131ft)	
H	Difference in height (Outdoor Unit ↔ Indoor Unit)	
	H ≤ 50m(164ft)	
h	Difference in height (Indoor Unit ↔ Indoor Unit)	
	h ≤ 15m(49ft)	
"a", "b"	Difference in height(HR unit ↔ HR unit)	
	a ≤ 15m(49ft) , b ≤ 5m(16ft)	

- \* : Assume equivalent pipe length of Y branch to be 500mm(19-5/8inch), that of header to be 1000mm(39-1/4inch), calculation purpose
- It is recommended that indoor unit is installed at lower position than the header.

 **WARNING**

When the any one (or both) of below conditions are satisfied, the diameter of main pipe (A) must be increased according to below table.

- The equivalent length between outdoor unit and the farthest indoor unit is 90m(295ft) or more (Liquid, High pressure gas pipes and Low pressure gas pipes are increased)
- The level difference (Outdoor unit ↔ Indoor unit) is 50m(164ft) or more (Only liquid pipe is increased)

## Refrigerant pipe diameter from outdoor unit to first branch. (A)

Upward outdoor unit total capacity	Pipe diameter			Pipe diameter when pipe length is ≥ 90m(295 ft)		
	Liquid mm(inch)	Low pressure gas pipe mm(inch)	High pressure gas pipe mm(inch)	Liquid mm(inch)	Low pressure gas pipe mm(inch)	High pressure gas pipe mm(inch)
Ton						
3,4,5	Ø9.52 (3/8)	Ø19.05 (3/4)	Ø15.88 (5/8)	Ø 12.7 (1/2)	Ø 22.2 (7/8)	Ø 19.05 (3/4)

Y branch, Header and HR unit connection pattern

Pattern 1

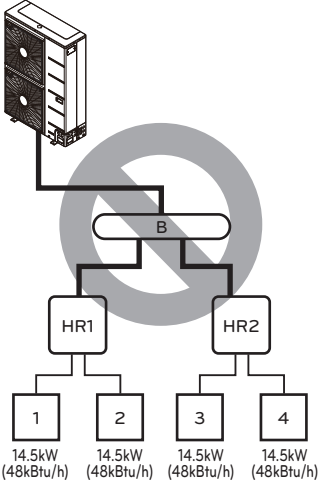

• Impossible installation : Head branch pipe → HR unit

Pattern 2

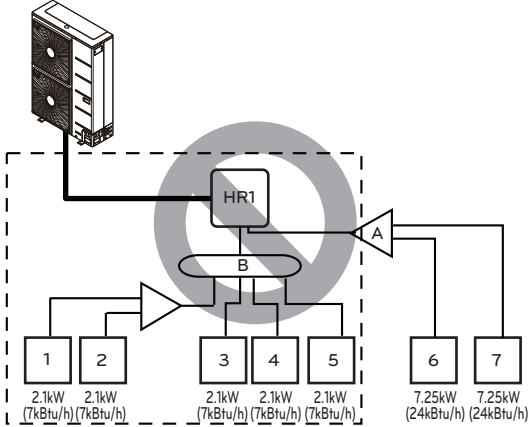

• Impossible installation : HR unit → Head branch pipe  
pipe → Y and Head branch pipe.

Pattern 3

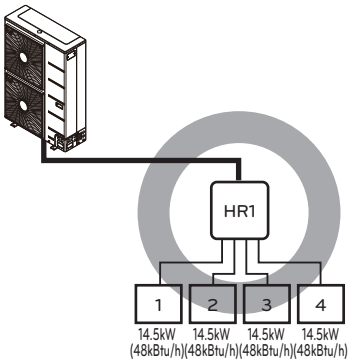

• The maximum total capacity of indoor units is 58kW(192 kBtu/h).

Pattern 4

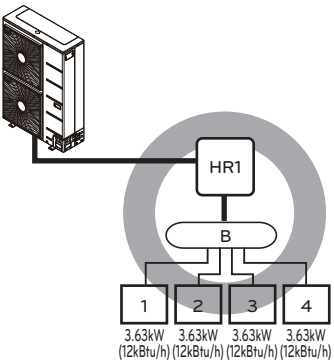

• The maximum total capacity of a branch pipe of HR unit is 14.5kW(48 kBtu/h).

Pattern 5

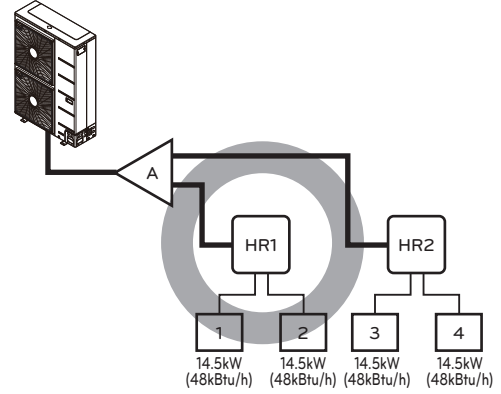

Pattern 6

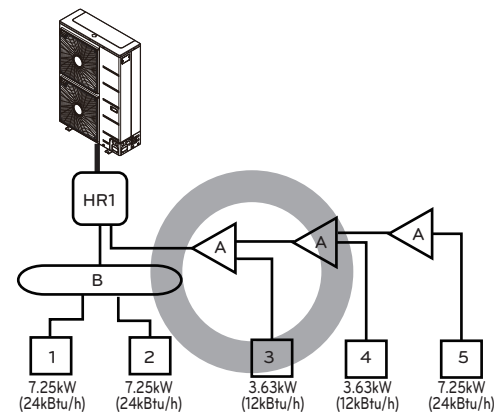

Pattern 7

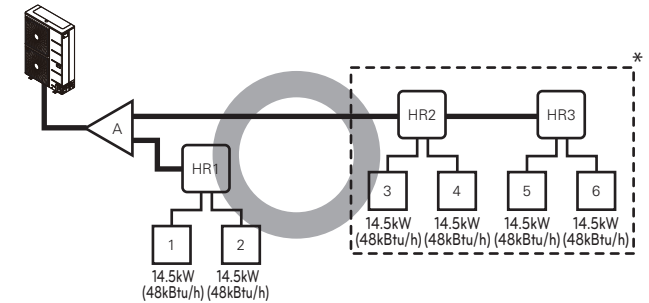

• \* : Serial connection of HR units : Capacity sum of indoor units ≤ 192 kBtu/h

Pattern 8

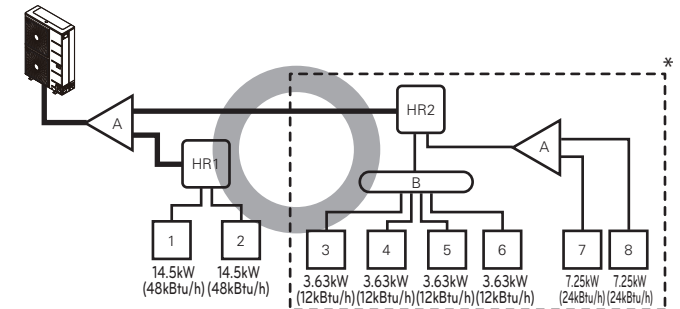

• \* : Maximum indoor units per a branch are 8 indoor units

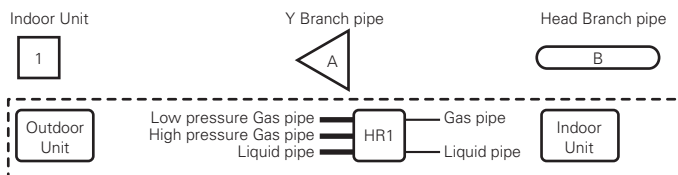

• Pipe installation from outdoor units to HR units  
—— : 3 pipes(Low pressure Gas pipe, High pressure Gas pipe, Liquid pipe)

• Pipe installation from HR units to indoor units  
—— : 2 pipes(Gas pipe, Liquid pipe)

- Keep the 40m(131ft) distance from the first branch to the farthest indoor.

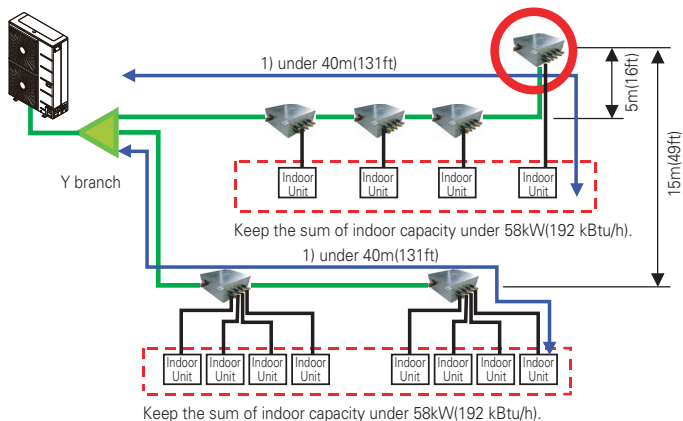

### For Heat Pump System Installation

#### Preparation Work

- Use Knock Outs of Cover of the outdoor unit for Front/Right or Rear pipe drawing outs.

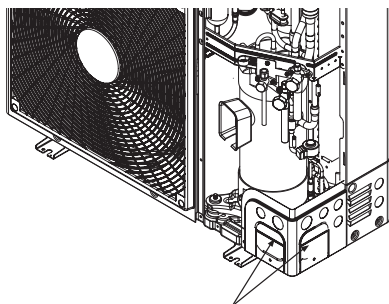

Removal Area for Liquid/Gas pipe front or right side connections.

#### CAUTION

- Do not give damage to the pipe/base during the Knock Out work.
- Proceed to pipe work after removing burr after Knock Out work.
- Perform sleeve work to prevent damage to the wire when connecting wires using Knock Outs.

#### Remove leakage prevention cap

- Remove the leakage prevention cap attached to the outdoor unit service valve before pipe work.
- Proceed the leakage prevention cap removal as follows:
  - Verify whether all the pipes are locked.
  - Extract remaining refrigerant or air inside using the service port.
  - Remove the leakage prevention cap

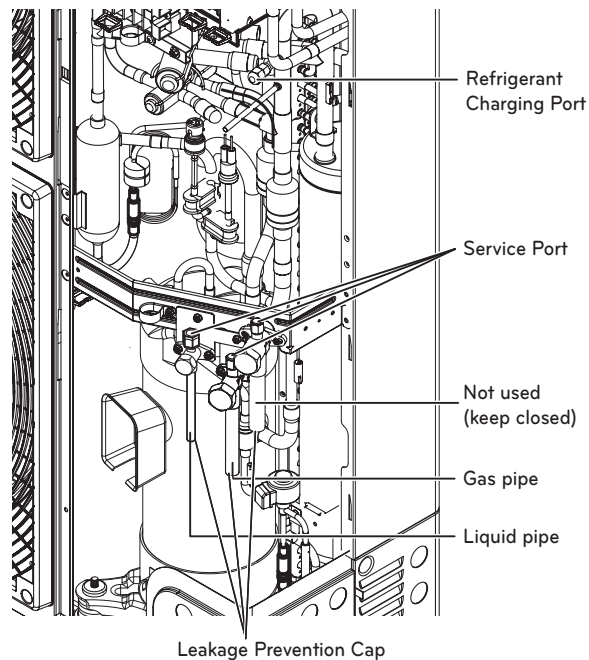

#### Pipe Drawing Out during Single connection

##### Method of drawing out pipes on the front side and right side

- Proceed with the pipe work as shown in the below figure for front side and right side pipe drawing out.

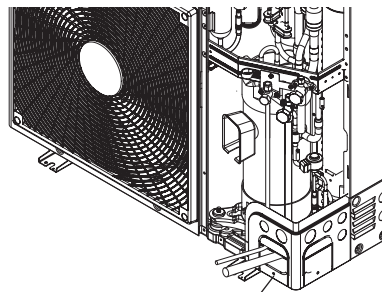

Pipe Knock Out for Liquid/Gas pipes

##### Method of drawing out pipes on the rear side

- Proceed with the pipe work as shown in the below figure for rear side pipe drawing out.

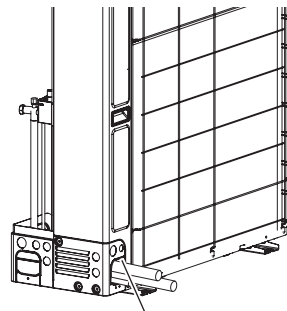

Pipe Knock Out for Liquid/Gas pipes

※ Pictures may differ depending on the model.

## Refrigerant piping system

### Y branch method

Example : 5 Indoor Units connected

- Ⓐ : Outdoor Unit
- Ⓑ : 1st branch (Y branch)
- Ⓒ : Indoor Units

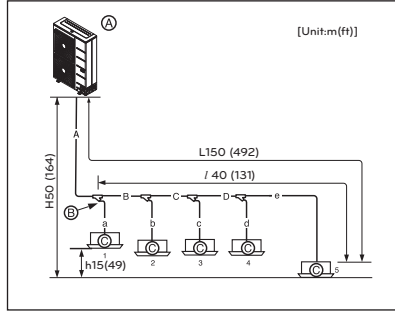

Total pipe length = A+B+C+D+a+b+c+d+e ≤ 300m(984ft)

L	Longest pipe length	Equivalent pipe length(*)
	A+B+C+D+e ≤ 150m(492ft)	A+B+C+D+e ≤ 175m(574ft)
l	Longest pipe length after 1st branch	
	B+C+D+e ≤ 40m(131ft)	
H	Difference in height (Outdoor Unit ↔ Indoor Unit)	
	H ≤ 50m(164ft)/40m(131ft) : Outdoor Unit is lower than Indoor Units	
h	Difference in height (Indoor Unit ↔ Indoor Unit)	
	h ≤ 15m(49ft)	

- \* : Assume equivalent pipe length of Y branch to be 0.5m(1.6ft), that of header to be 1m(3.3ft), calculation purpose

### Refrigerant pipe diameter from outdoor unit to first branch. (A)

Outdoor unit capacity [Ton]	Liquid pipe [mm(inch)]	Gas pipe [mm(inch)]
3, 4	Ø9.52(3/8)	Ø15.88(5/8)

### Refrigerant pipe diameter from branch to branch (B,C,D)

Downward Indoor Unit total capacity [kW(Btu/h)]	Liquid pipe [mm(inch)]	Gas pipe [mm(inch)]
≤ 5.6(19,100)	Ø6.35(1/4)	Ø12.7(1/2)
< 16.0(54,600)	Ø9.52(3/8)	Ø15.88(5/8)
≤ 22.4(76,400)	Ø9.52(3/8)	Ø19.05(3/4)
< 36.4(124,200)	Ø9.52(3/8)	Ø22.2(7/8)

### WARNING

When the any one (or both ) of below conditions are satisfied, the diameter of main pipe (A) must be increased according to below table.

- The equivalent length between outdoor unit and the farthest indoor unit is 90m or more (Liquid and Gas pipes are increased)
- The level difference (Outdoor unit ↔ Indoor unit) is 50m or more (Only liquid pipe is increased)

### Header Method

Example : 6 Indoor Units connected

- Ⓐ : Outdoor Unit
- Ⓑ : 1st branch
- Ⓒ : Indoor Units
- Ⓓ : Sealed piping

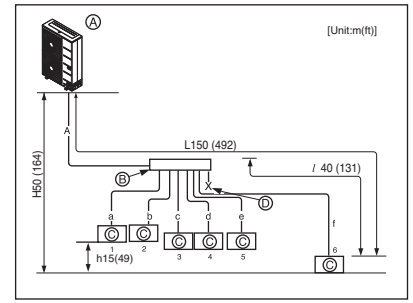

Total pipe length = A+a+b+c+d+e+f ≤ 300m(984ft)

L	Longest pipe length	Equivalent pipe length(*)
	A+f ≤ 150m(492ft)	A+f ≤ 175m(574ft)
l	Longest pipe length after 1st branch	
	f ≤ 40m(131ft)	
H	Difference in height (Outdoor Unit ↔ Indoor Unit)	
	H ≤ 50m(164ft)/40m(131ft) : Outdoor Unit is lower than Indoor Units	
h	Difference in height (Indoor Unit ↔ Indoor Unit)	
	h ≤ 15m(49ft)	

### WARNING

Pipe length after header branching (a~f)

It is recommended that difference in length of the pipes connected to the Indoor Units is minimized. Performance difference between Indoor Units may occur.

- \* : Assume equivalent pipe length of Y branch to be 0.5m(1.6ft), that of header to be 1m(3.3ft), calculation purpose
- It is recommended that indoor unit is installed at lower position than the header.

### Combination of Y branch/header Method

Example : 5 Indoor Units connected

- Ⓐ : Outdoor Unit
- Ⓑ : 1st branch (Y branch)
- Ⓒ : Y branch
- Ⓓ : Indoor Unit
- Ⓔ : Header
- Ⓕ : Sealed piping

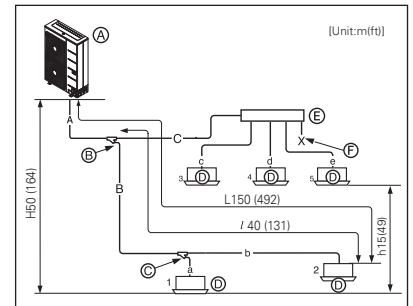

Branch pipe can not be used after header

Total pipe length = A+B+C+a+b+c+d+e ≤ 300m(984ft)

L	Longest pipe length	Equivalent pipe length(*)
	A+B+b ≤ 150m(492ft)	A+B+b ≤ 175m(574ft)
l	Longest pipe length after 1st branch	
	B+b ≤ 40m(131ft)	
H	Difference in height (Outdoor Unit ↔ Indoor Unit)	
	H ≤ 50m(164ft) 40m(131ft) : Outdoor Unit is lower than Indoor Units	
h	Difference in height (Indoor Unit ↔ Indoor Unit)	
	h ≤ 15m(49ft)	

- \* : Assume equivalent pipe length of Y branch to be 0.5m(1.6ft), that of header to be 1m(3.3ft), calculation purpose
- Indoor Unit should be installed at lower position than the header.

**WARNING**

- It is recommended that difference of piping length for pipes connected to the Indoor Unit is minimized. Performance difference between Indoor Units may occur.
- When the any one (or both ) of below conditions are satisfied, the diameter of main pipe (A) must be increased according to below table.
  - The equivalent length between outdoor unit and the farthest indoor unit is 90 m or more. (Liquid and Gas pipes are increased.)

**Refrigerant pipe diameter from outdoor unit to first branch. (A)**

System(Ton)	Liquid pipe [mm(inch)]	Gas pipe [mm(inch)]
3, 4	Ø 9.52(3/8)	Ø 15.88(5/8)

**Refrigerant pipe diameter from branch to branch (B,C)**

Downward Indoor Unit total capacity [kW(Btu/h)]	Liquid pipe [mm(inch)]	Gas pipe [mm(inch)]
≤ 5.6(19 100)	Ø 6.35(1/4)	Ø 12.7(1/2)
< 16.0(54 600)	Ø 9.52(3/8)	Ø 15.88(5/8)
≤ 22.4(76 400)	Ø 9.52(3/8)	Ø 19.05(3/4)

**Outdoor unit Connection****WARNING**

- In case of pipe diameter B connected after first branch is bigger than the main pipe diameter A, B should be of the same size with A.

Ex) In case indoor unit combination ratio 120 % is connected to 24 HP(67.2 kW) outdoor unit.

- Outdoor unit main pipe diameter A : Ø 34.9(Gas pipe), Ø 15.88(liquid pipe)
- Pipe diameter B after first branch according to 120 % indoor unit ombination(80.6kW) : Ø 34.9(gas pipe), Ø 19.05(liquid pipe)

Therefore, pipe diameter B connected after first branch would be Ø 34.9(gas pipe) / Ø 15.88(liquid pipe) which is same with main pipe diameter.

**[Example]**

Do not choose the main pipe diameter by downward indoor unit total capacity but its outdoor unit model name.

Do not let the connection pipe from branch to branch exceed the main pipe diameter chosen by outdoor unit model name.

Ex) Where connecting the indoor units to the 22 HP (61.6 kW) outdoor unit to 130 % of its system capacity (80.1 kW) and branching 7k (2.2 kW) indoor unit at the 1st branch.

- Main pipe diameter(22 HP outdoor unit): Ø 28.58(gas pipe), Ø 15.88(Liquid pipe)
- Pipe diameter between 1st and 2nd branch (77.9 kW indoor units) : Ø 34.9(Gas pipe), Ø 19.05(Liquid pipe) in conformity with downward indoor units.

Since the main pipe diameter of 22 HP outdoor unit is Ø 28.58(gas pipe), Ø 15.88(Liquid pipe) is used as the main pipe and the connection pipe between 1st and 2nd branch.

**Indoor Unit Connection****Indoor Unit connecting pipe from branch (a,b,c,d,e,f)**

Indoor Unit capacity [kW(Btu/h)]	Liquid pipe [mm(inch)]	Gas pipe [mm(inch)]
≤ 5.6(19,100)	Ø6.35(1/4)	Ø12.7(1/2)
< 16.0(54,600)	Ø9.52(3/8)	Ø15.88(5/8)
< 22.4(76,400)	Ø9.52(3/8)	Ø19.05(3/4)
< 28.0(95,900)	Ø9.52(3/8)	Ø22.2(7/8)

**CAUTION**

- Bending radius should be at least twice the diameter of the pipe.
- Bend pipe after 500mm (19-5/8inch) or more from branch(or header). Do not bend U type. It may cause Performance unsatisfactory or noise.

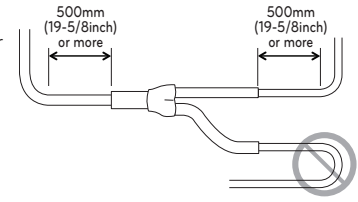
**The amount of Refrigerant**

The calculation of the additional charge should take into account the length of pipe and CF(correction Factor) value of indoor unit.

Additional charge(kg)	=	Total liquid pipe : Ø25.4 mm (1.0 inch)	x 0.480 kg/m (0.323 lbs/ft)
	+	Total liquid pipe : Ø22.2 mm (7/8 inch)	x 0.354 kg/m (0.238 lbs/ft)
	+	Total liquid pipe : Ø19.05 mm (3/4 inch)	x 0.266 kg/m (0.179 lbs/ft)
	+	Total liquid pipe : Ø15.88 mm (5/8 inch)	x 0.173 kg/m (0.116 lbs/ft)
	+	Total liquid pipe : Ø12.7 mm (1/2inch)	x 0.118 kg/m (0.079 lbs/ft)
	+	Total liquid pipe : Ø9.52 mm (3/8inch)	x 0.061 kg/m (0.041 lbs/ft)
	+	Total liquid pipe : Ø6.35 mm (1/4 inch)	x 0.022 kg/m (0.015 lbs/ft)
	+	Number of installed HR unit	x 0.5 kg (1.1 lbs)
			※ 6 & 8 Branches
			Model : 1.0kg/EA
	+	CF value of indoor unit	(2.2 lbs/EA)

**Amount refrigerant of Indoor units**

Example) 4Way Ceiling Cassette 14.5kW -1ea, Ceiling concealed Duct 7.3kW-2ea, Wall Mounted 2.3kW-4ea  
CF = 0.64 × 1 + 0.26 × 2 + 0.24 × 4 = 2.12kg(4.67lbs)

Attach the additional refrigerant table of IDU.

**WARNING**

- Regulation for refrigerant leakage : the amount of refrigerant leakage should satisfy the following equation for human safety.

$$\frac{\text{Total amount of refrigerant in the system}}{\text{Volume of the room at which Indoor Unit of the least capacity is installed}} \leq \frac{0.44\text{kg/m}^3}{(0.028\text{lbs/ft}^3)}$$

If the above equation can not be satisfied, then follow the following steps.

- Selection of air conditioning system: select one of the next
  - Installation of effective opening part
  - Reconfirmation of Outdoor Unit capacity and piping length
  - Reduction of the amount of refrigerant
  - Installation of 2 or more security device (alarm for gas leakage)
- Change Indoor Unit type : installation position should be over 2m(6.6ft) from the floor (Wall mounted type → Cassette type)
- Adoption of ventilation system : choose ordinary ventilation system or building ventilation system
- Limitation in piping work : Prepare for earthquake and thermal stress

## Refrigerant charging

### For Heat Recovery System Installation

- Ⓐ Manifold Gauge
- Ⓑ Low pressure side Handle
- Ⓒ High pressure side Handle

#### ARUB\*\*\*GSS4

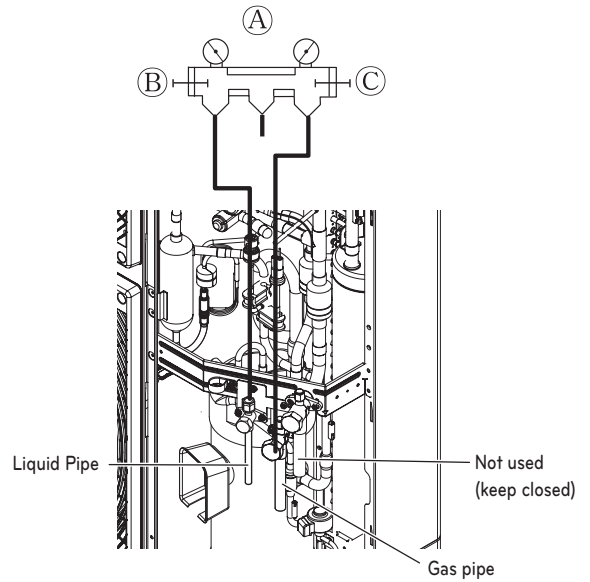
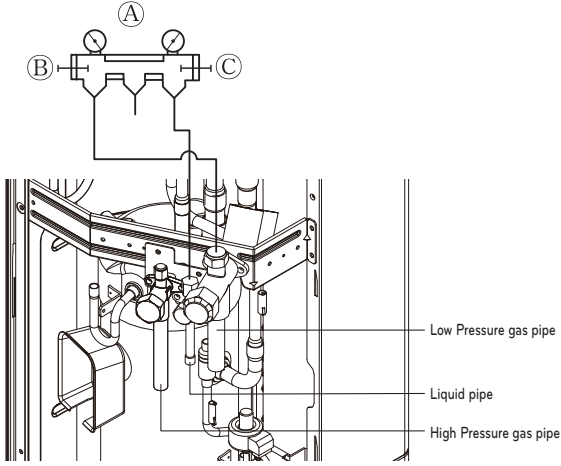

#### ARUM\*\*\*GSS5

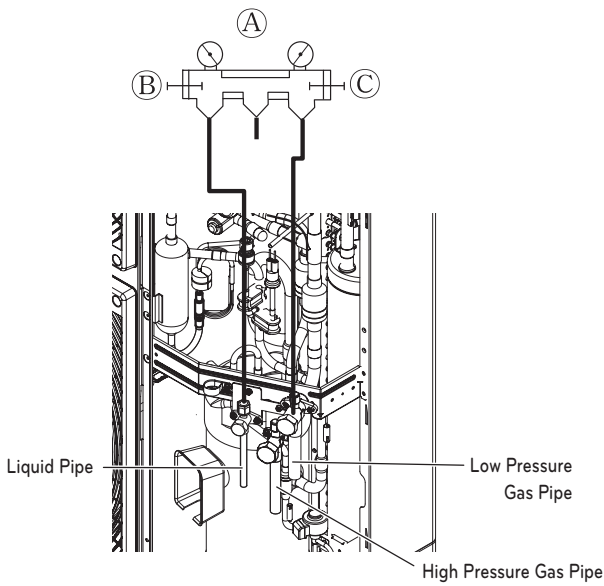

### ⚠ WARNING

- Pipe to be vacuumed : gas pipe, liquid pipe
- If the refrigerant amount is not exact, it may not operate properly.
- If additionally bottled refrigerant amount is over 10 %, condenser burst or insufficient indoor unit performance may be caused.
- Low pressure gas pipe should be sealed with a cap in piping accessories during refrigerant charging.

## Branch pipe Fitting

### Y branch

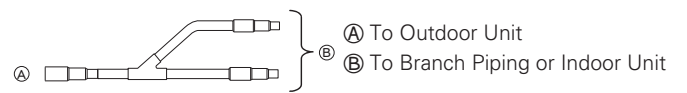

- Ensure that the branch pipes are attached horizontally or vertically. (see the diagram below.)

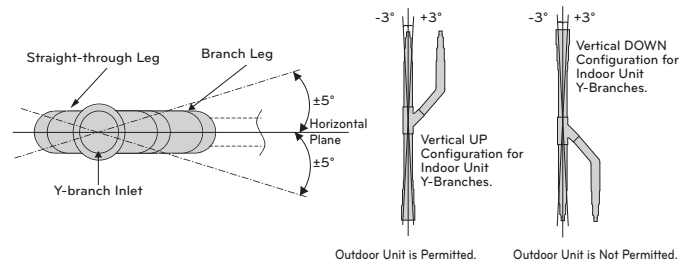

### For Heat Pump System Installation

- Ⓐ Manifold Gauge
- Ⓑ Low Pressure Side Handle
- Ⓒ High Pressure Side Handle

Outdoor unit Y-branches can only be installed in a horizontal or vertical UP configuration.

The vertical DOWN configuration is not permitted.

- There is no limitation on the joint mounting configuration.
- If the diameter of the refrigerant piping selected by the procedures described is different from the size of the joint, the connecting section should be cut with a pipe cutter.
- Branch pipe should be insulated with the insulator in each kit.

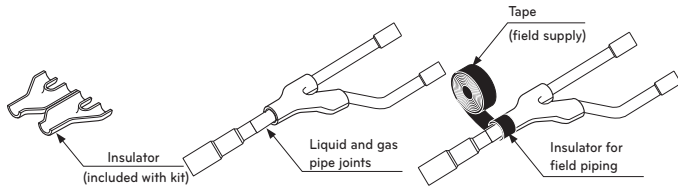

**Header**

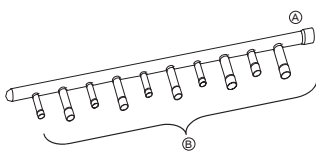

- (A) To Outdoor Unit
- (B) To Indoor Unit

- The indoor unit having larger capacity must be installed closer to (A) than smaller one.
- If the diameter of the refrigerant piping selected by the procedures described is different from the size of the joint, the connecting section should be cut with a pipe cutter.

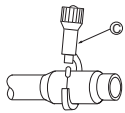

• (C) Pipe cutter

- When the number of pipes to be connected is smaller than the number of header branches, install a cap to the unconnected branches.

- When the number of indoor units to be connected to the branch pipes is less than the number of branch pipes available for connection then cap pipes should be fitted to the surplus branches.

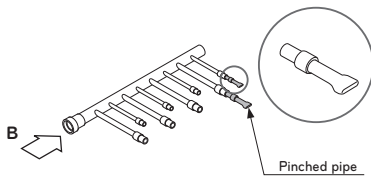

- Fit branch pipe lie in a horizontal plane.

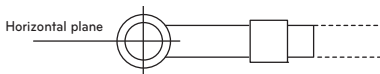

View from point B in the direction of the arrow

- Header should be insulated with the insulator in each kit.

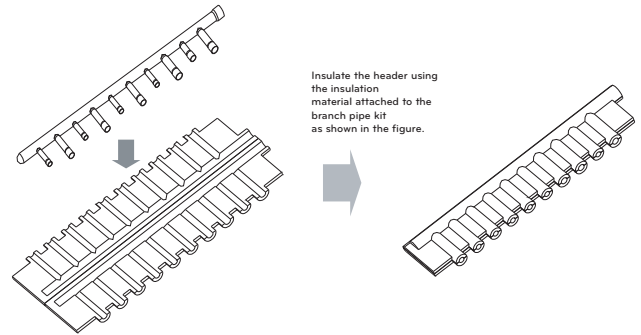

- Joints between branch and pipe should be sealed with the tape included in each kit.

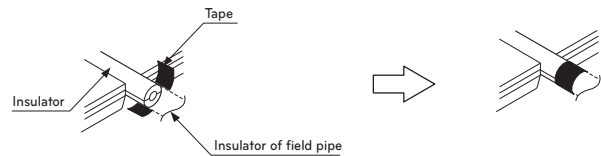

- Any cap pipe should be insulated using the insulator provided with each kit and then taped as described above.

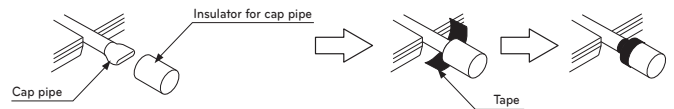

**Y branch pipe**

For Heat Recovery System Installation

\* For more information, refer accessory installation manual.

[Unit : mm(inch)]

Models	Pipe
ARBLB01621	<p>Low-Pressure Vapor Pipe</p>
	<p>Liquid pipe</p>
	<p>High-Pressure Vapor Pipe</p>
	<p>High-Pressure Vapor Pipe</p>

Models	Pipe
ARBLB03321	<p>Low-Pressure Vapor Pipe</p>
	<p>Liquid pipe</p>
	<p>High-Pressure Vapor Pipe</p>
	<p>High-Pressure Vapor Pipe</p>
ARBLB07121	<p>Low-Pressure Vapor Pipe</p>
	<p>Liquid pipe</p>
	<p>High-Pressure Vapor Pipe</p>
	<p>High-Pressure Vapor Pipe</p>

Models	Pipe
ARBLB14521	<p>Low-Pressure Vapor Pipe</p>
	<p>Liquid pipe</p>
	<p>High-Pressure Vapor Pipe</p>

Models	Pipe
ARBLN03321	<p>Gas pipe</p>
	<p>Liquid pipe</p>
ARBLN07121	<p>Gas pipe</p>
	<p>Liquid pipe</p>
ARBLN14521	<p>Gas pipe</p>
	<p>Liquid pipe</p>

For Heat Pump System Installation

\* For more information, refer accessory installation manual.

[Unit : mm(inch)]

Models	Pipe
ARBLN01621	<p>Gas pipe</p>
	<p>Liquid pipe</p>

Header

\* For more information, refer accessory installation manual.

[Unit:mm(inch)]

Models	Pipe
4 branch ARBL054	Gas pipe 
	Liquid pipe 
7 branch ARBL057	Gas pipe 
	Liquid pipe 
4 branch ARBL104	Gas pipe 
	Liquid pipe 
7 branch ARBL107	Gas pipe 
	Liquid pipe 

Models	Pipe
10 branch ARBL1010	Gas pipe 
	Liquid pipe 
10 branch ARBL2010	Gas pipe 
	Liquid pipe 

## Distribution Method

### Horizontal Distribution

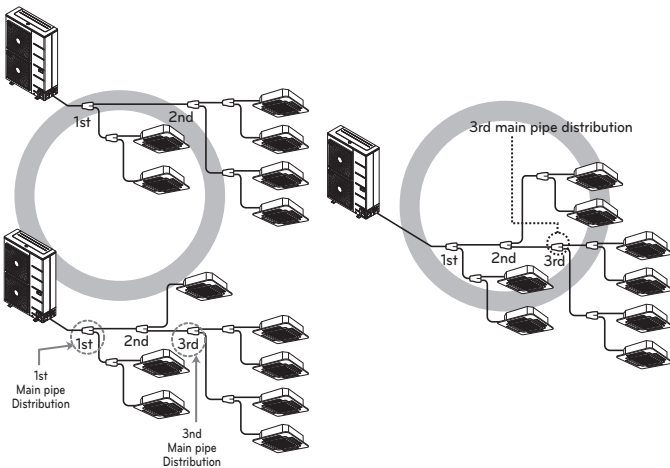

### Vertical Distribution

- Ensure that the branch pipes are attached vertically.

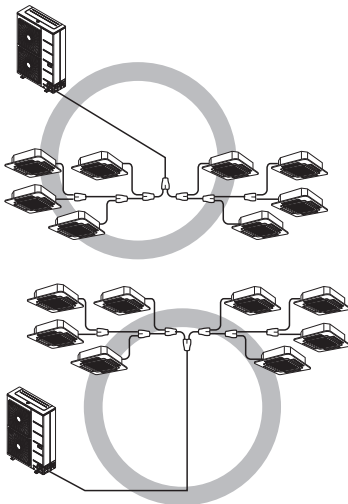

### The others

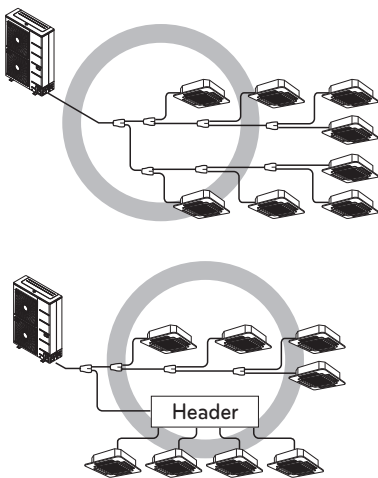

## Vacuum Mode

This function is used for creating vacuum in the system after compressor replacement, ODU parts replacement or IDU addition / replacement.

### Vacuum mode setting method

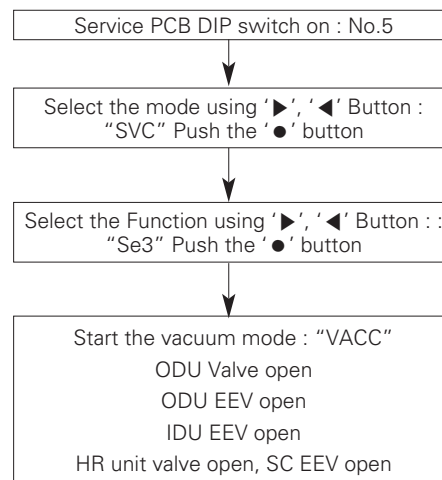
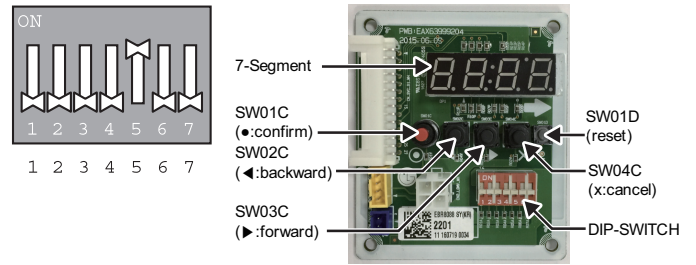

### Vacuum mode off method

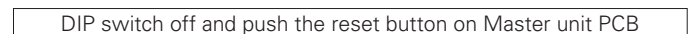

### CAUTION

ODU operation stops during vacuum mode. Compressor can't operate.

## Leak Test and Vacuum drying

### Leak test

Leak test should be made by pressurizing nitrogen gas to 3.8 MPa (551.1 psi). If the pressure does not drop for 24 hours, the system passes the test. If the pressure drops, check where the nitrogen leaks. For the test method, refer to the following figure. (Make a test with the service valves closed. Be also sure to pressurize liquid pipe, gas pipe and high pressure gas pipe)

The test result can be judged good if the pressure has not been reduced after leaving for about one day after completion of nitrogen gas pressurization.

### Installation Heat Recovery

#### ARUB\*\*\*GSS4

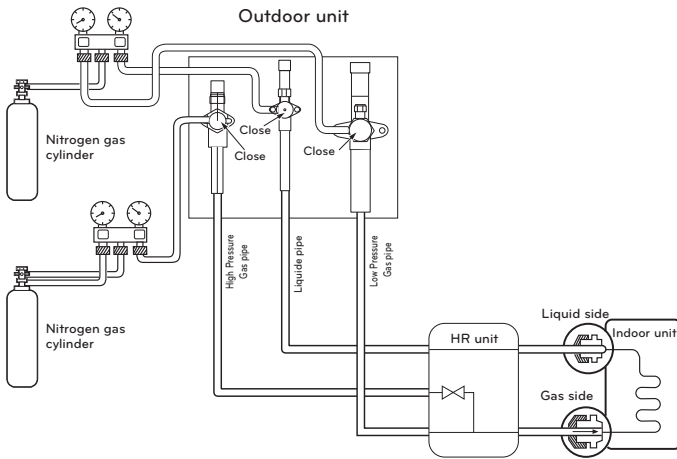

#### ARUM\*\*\*GSS5

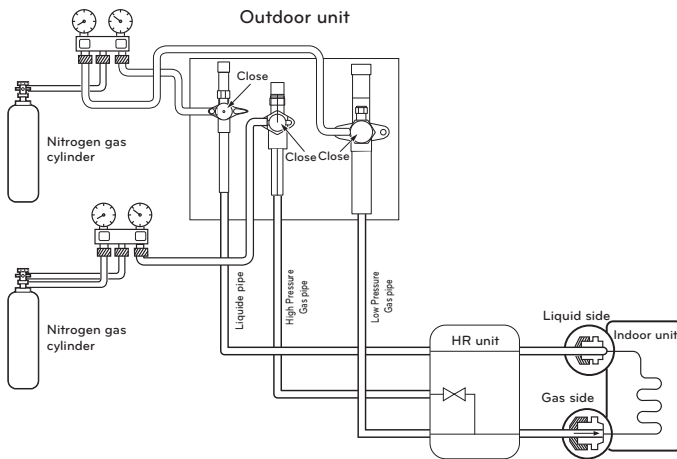

### Installation Heat Pump

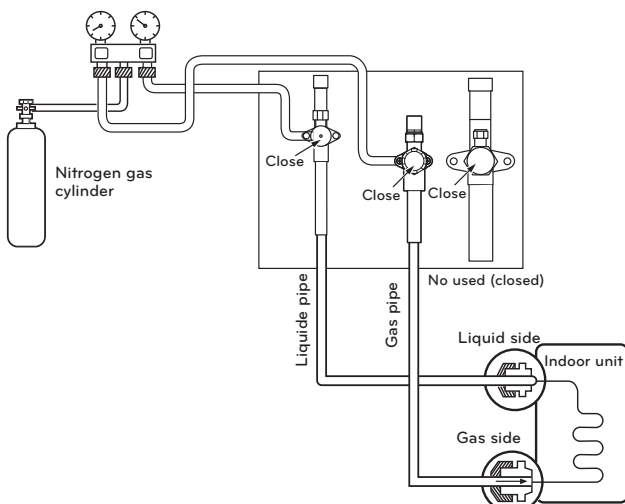

## WARNING

Use a vacuum pump or Inert(nitrogen) gas when doing leakage test or air purge. Do not compress air or Oxygen and do not use Flammable gases. Otherwise, it may cause fire or explosion.  
- There is the risk of death, injury, fire or explosion.

## NOTE

If the ambient temperature differs between the time when pressure is applied and when the pressure drop is checked, apply the following correction factor

There is a pressure change of approximately 0.01 MPa(1.5 psi) for each 33.8 °F (1 °C) of temperature difference.

Correction= (Temp. at the time of pressurization – Temp. at the time of check) X 0.1

For example: Temperature at the time of pressurization 3.8

MPa(551 psi) is 80.6 °F (27 °C)

24 hour later: 3.73 MPa(541 psi), 68 °F (20 °C)

In this case the pressure drop of 0.07 MPa

(10 psi) is because of temperature drop

And hence there is no leakage in pipe occurred.

## CAUTION

To prevent the nitrogen from entering the refrigeration system in the liquid state, the top of the cylinder must be at higher position than the bottom when you pressurize the system.

Usually the cylinder is used in a vertical standing position.

### Vacuum

Vacuum drying should be made from the service port provided on the outdoor unit's service valve to the vacuum pump commonly used for liquid pipe, gas pipe and high/low pressure common pipe. (Make Vacuum from liquid pipe, gas pipe and high/low pressure common pipe with the service valve closed.)

\* Never perform air purging using refrigerant.

- Vacuum drying: Use a vacuum pump that can evacuate to -100.7 kPa (-14.6 psi, 5 Torr, -755 mmHg).

- Evacuate the system from the liquid and gas pipes with a vacuum pump for over 2 hrs and bring the system to -100.7 kPa(-14.6 psi). After maintaining system under that condition for over 1 hr, confirm the vacuum gauge rises. The system may contain moisture or leak.

- Following should be executed if there is a possibility of moisture remaining inside the pipe.

(Rainwater may enter the pipe during work in the rainy season or over a long period of time)

After evacuating the system for 2 hrs, give pressure to the system to 0.05 MPa(7.3 psi) (vacuum break) with nitrogen gas and then evacuate it again with the vacuum pump for 1hr to -100.7 kPa (-14.6 psi)(vacuum drying). If the system cannot be evacuated to -100.7 kPa(-14.6 psi) within 2 hrs, repeat the steps of vacuum break and its drying. Finally, check if the vacuum gauge does not rise or not, after maintaining the system in vacuum for 1 hr.

### Installation Heat Recovery

#### ARUB\*\*\*GSS4

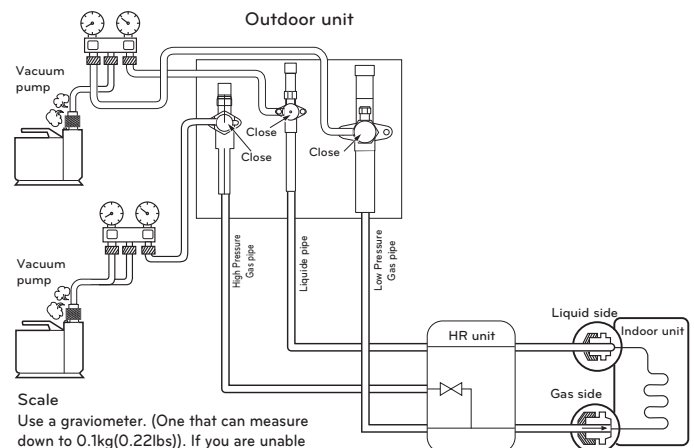

### Scale

Use a gravimeter. (One that can measure down to 0.1kg(0.22lbs)). If you are unable to prepare such a high-precision gravimeter you may use a charge cylinder.

ARUM\*\*\*GSS5

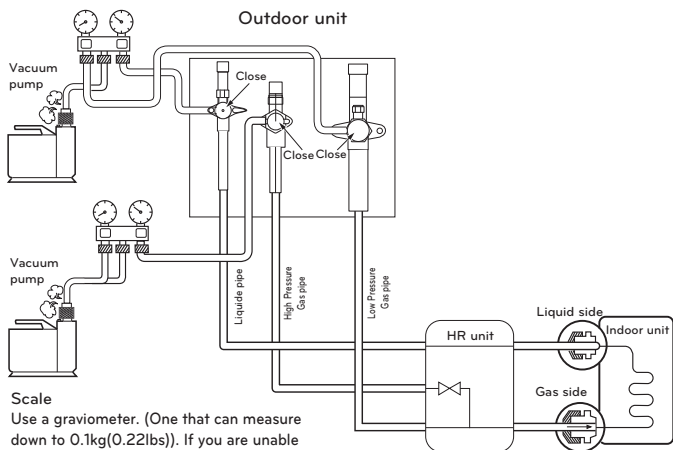

**Scale**  
Use a gravimeter. (One that can measure down to 0.1kg(0.22lbs)). If you are unable to prepare such a high-precision gravimeter you may use a charge cylinder.

Installation Heat Pump

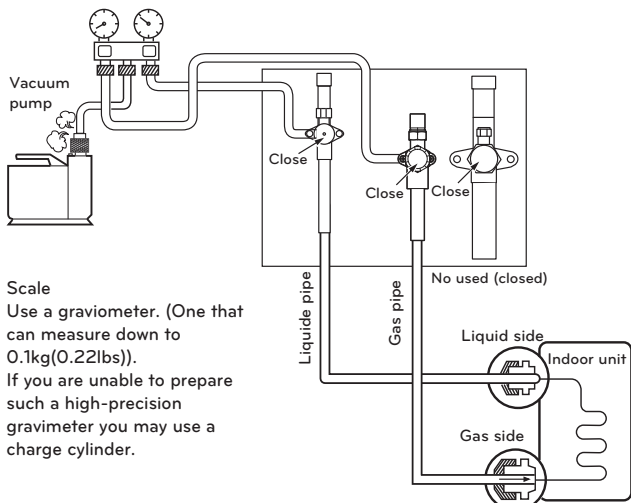

**Scale**  
Use a gravimeter. (One that can measure down to 0.1kg(0.22lbs)). If you are unable to prepare such a high-precision gravimeter you may use a charge cylinder.

Thermal insulation of refrigerant piping

Be sure to give insulation work to refrigerant piping by covering liquid pipe and gas pipe separately with enough thickness heat-resistant polyethylene, so that no gap is observed in the joint between indoor unit and insulating material, and insulating materials themselves. When insulation work is insufficient, there is a possibility of condensation drip, etc. Pay special attention to insulation work to ceiling plenum.

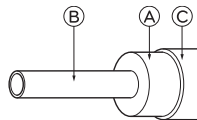

Heat insulation material	Adhesive + Heat - resistant polyethylene foam + Adhesive tape	
Outer covering	Indoor	Vinyl tape
	Floor exposed	Water-proof hemp cloth + Bronze asphalt
	Outdoor	Water-proof hemp cloth + Zinc plate + Oily paint

- Ⓐ Heat insulation material
- Ⓑ Pipe
- Ⓒ Outer covering(Wind the connection part and cutting part of heat insulation material with a finishing tape.)

**NOTE**

When using polyethylene cover as covering material, asphalt roofing shall not be required.

Bad example

- Do not insulate gas or low pressure pipe and liquid or highpressure pipe together.

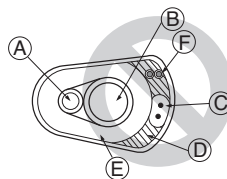

- Ⓐ Liquid pipe
- Ⓑ Gas pipe
- Ⓒ Power lines
- Ⓓ Finishing tape
- Ⓔ Insulating material
- Ⓕ Communication lines

- Be sure to fully insulate connecting portion.

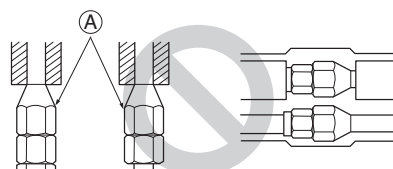

Ⓐ These parts are not insulated.

Good example

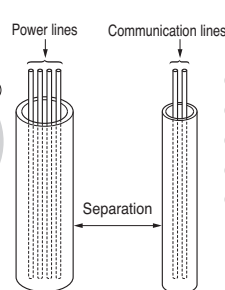
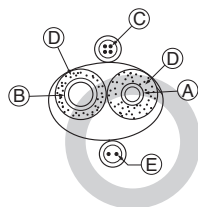

- Ⓐ Liquid pipe
- Ⓑ Gas pipe
- Ⓒ Power lines
- Ⓓ Insulating material
- Ⓔ Communication lines

**WARNING**

Use a vacuum pump or Inert(nitrogen) gas when doing leakage test or air purge. Do not compress air or Oxygen and do not use Flammable gases. Otherwise, it may cause fire or explosion.  
- There is the risk of death, injury, fire or explosion.

**NOTE**

Always add an appropriate amount of refrigerant. (For the refrigerant additional charge)  
Too much or too little refrigerant will cause trouble.  
To use the Vacuum Mode (If the Vacuum mode is set, all valves of Indoor units and Outdoor units will be opened.)

**WARNING**

When installing and moving the air conditioner to another site, recharge after perfect evacuation.  
- If a different refrigerant or air is mixed with the original refrigerant, the refrigerant cycle may malfunction and the unit may be damaged.

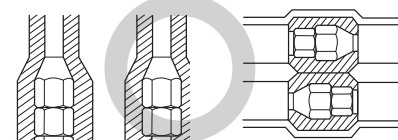

## Penetrations

Inner wall (concealed)

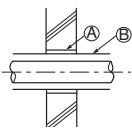

Outer wall

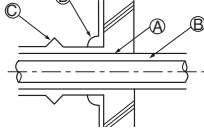

Outer wall (exposed)

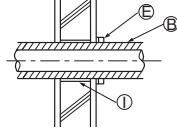

Floor (fireproofing)

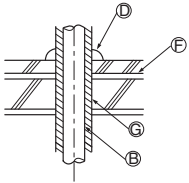

Penetrating portion on fire limit and boundary wall

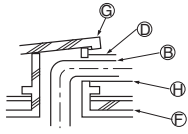

Roof pipe shaft

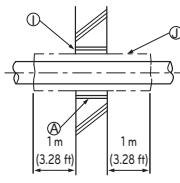

- (A) Sleeve
- (B) Heat insulating material
- (C) Lagging
- (D) Caulking material
- (E) Band
- (F) Waterproofing layer
- (G) Sleeve with edge
- (H) Lagging material
- (I) Mortar or other incombustible caulking
- (J) Incombustible heat insulation material

When filling a gap with mortar, cover the penetration part with steel plate so that the insulation material will not be caved in. For this part, use incombustible materials for both insulation and covering. (Vinyl covering should not be used.)

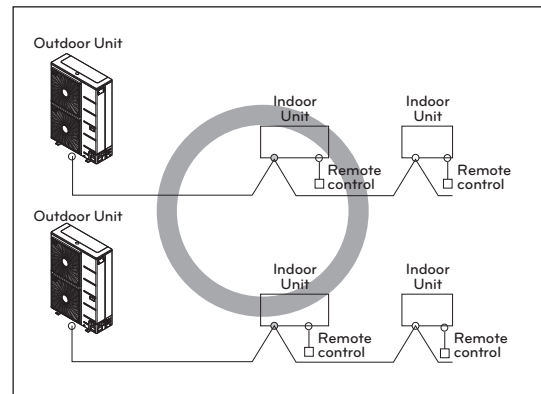

2-Core Shield Cable

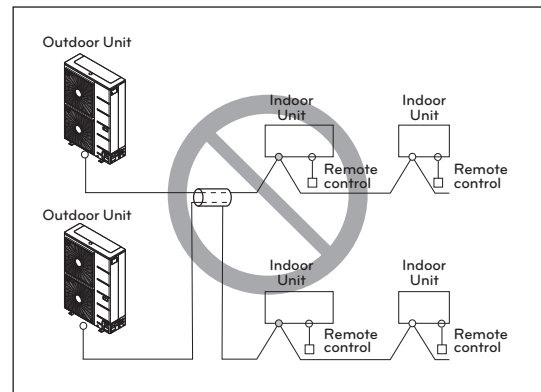

Multi-Core Cable

## ELECTRICAL WIRING

### Caution

- Follow ordinance of your governmental organization for technical standard related to electrical equipment, wiring regulations and guidance of each electric power company.

### WARNING

Be sure to have authorized electrical engineers do the electric work using special circuits in accordance with regulations and this installation manual.  
If power supply circuit has a lack of capacity or electric work deficiency, it may cause an electric shock or fire.

- Install the Outdoor Unit communication cable away from the power source wiring so that it is not affected by electric noise from the power source. (Do not run it through the same conduit.)
- Be sure to provide designated grounding work to Outdoor Unit.

### CAUTION

Be sure to correct the outdoor unit to earth. Do not connect ground wire to any gas pipe, liquid pipe, lightning rod or telephone earth line. If earth is incomplete, it may cause an electric shock.

- Give some allowance to wiring for electrical part box of Indoor and Outdoor Units, because the box is sometimes removed at the time of service work.
- Never connect the main power source to terminal block of communication cable. If connected, electrical parts will be burnt out.
- Use the 2-core shielded wires or 2-core unshielded wires for communication cable. (○ mark in the figure below) If communication cable of different systems are wired with the same multicore cable, the resultant poor transmitting and receiving will cause erroneous operations. (⊗ mark in the figure below)
- Only the communication cable specified should be connected to the terminal block for Outdoor Unit communication.

### CAUTION

- Use the 2-core shielded wires or 2-core unshielded wires for communication cables. Never use them together with power cables.
- The conductive shielding layer of cable should be grounded to the metal part of both units.
- Never use multi-core cable
- As this unit is equipped with an inverter, to install a phase leading capacitor not only will deteriorate power factor improvement effect, but also may cause capacitor abnormal heating. Therefore, never install a phase leading capacitor.
- Make sure that the power unbalance ratio is not greater than 2 %. If it is greater the units lifespan will be reduced.

### Precautions when laying power wiring

Use round pressure terminals for connections to the power terminal block.

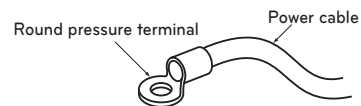

When none are available, follow the instructions below.

- Do not connect wiring of different thicknesses to the power terminal block. (Slack in the power wiring may cause abnormal heat.)
- When connecting cable which is the same thickness, do as shown in the figure below.

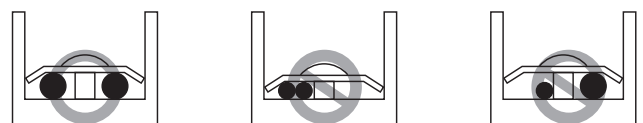

- For wiring, use the designated power cable and connect firmly, then secure to prevent outside pressure being exerted on the terminal block.
- Use an appropriate screwdriver for tightening the terminal screws. A screwdriver with a small head will strip the head and make proper tightening impossible.
- Over-tightening the terminal screws may break them.

## Control box and connecting position of wiring

- Remove all of the screws at front panel and remove the panel by pulling it forward.
- Connect communication cables between outdoor unit and indoor units through the terminal block.
- When the central control system is connected to the outdoor unit, a dedicated PCB must be connected between them.
- When connecting communication cable between outdoor unit and indoor units with shielded cable, connect the shield ground to the earth screw.
- Be sure to also make grounding connections to ground screws when connecting shielded wires to the central control system.

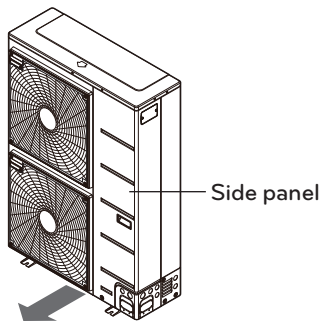

### WARNING

The temperature sensor for outdoor air should not be exposed to direct sunlight.  
- Provide an appropriate cover to intercept direct sunlight.

#### ARUB\*\*\*GSS4

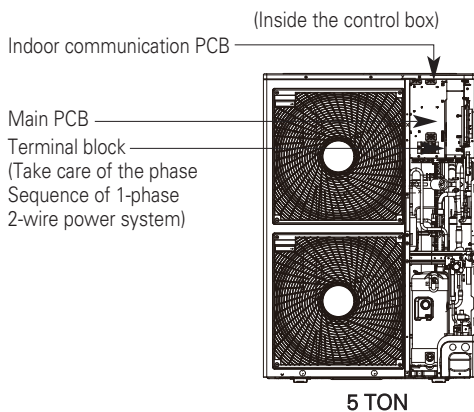

※ Pictures may differ depending on the model.

#### ARUM\*\*\*GSS5

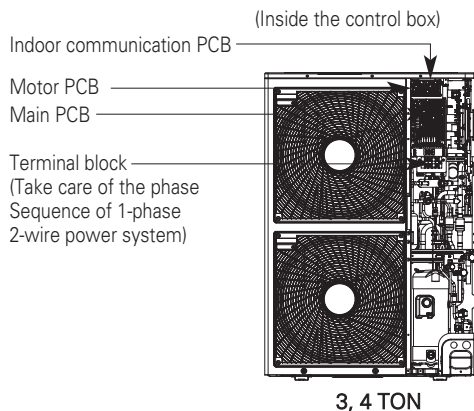

※ Pictures may differ depending on the model.

## Communication and Power Cables

### Communication cable

- Types : shielded wires or unshielded wires
- Cross section :  $1.0 \sim 1.5 \text{ mm}^2$  ( $1.55 \times 10^{-3} \sim 2.32 \times 10^{-3} \text{ in}^2$ )
- Maximum allowable temperature:  $60 \text{ }^\circ\text{C}$  ( $140 \text{ }^\circ\text{F}$ )
- Maximum allowable cable length: under 1 000 m (3 281 ft)

### Remote control cable

- Types : 3-core cables

### Central control cable

Product type	Cable type	Diameter
ACP&AC Manager	2-core cable (Shielding cable)	$1.0 \sim 1.5 \text{ mm}^2$ ( $1.55 \times 10^{-3} \sim 2.32 \times 10^{-3} \text{ in}^2$ )
AC Smart	2-core cable (Shielding cable)	$1.0 \sim 1.5 \text{ mm}^2$ ( $1.55 \times 10^{-3} \sim 2.32 \times 10^{-3} \text{ in}^2$ )
Simple central controller	4-core cable (Shielding cable)	$1.0 \sim 1.5 \text{ mm}^2$ ( $1.55 \times 10^{-3} \sim 2.32 \times 10^{-3} \text{ in}^2$ )

### CAUTION

In case of using the shielded wires, it should be grounded.

### Separation of communication and power cables

- If communication and power cables are installed alongside each other then there is a strong likelihood of operational faults developing due to interference in the signal wiring caused by electrostatic and electromagnetic coupling.
- The tables below indicates our recommendation as to appropriate spacing of communication and power cables where these are to be run side by side

	Current capacity of power cable	Spacing
100 V or more	10 A	300 mm (11-13/16 inch)
	50 A	500 mm (19-11/16 inch)
	100 A	1 000 mm (39-3/8 inch)
	Exceed 100 A	1 500 mm (59-1/16 inch)

### NOTE

- The figures are based on assumed length of parallel cabling up to 100 m [328 ft]. For length in excess of 100 m [328 ft] the figures will have to be recalculated in direct proportion to the additional length of cable involved.
- If the power supply waveform continues to exhibit some distortion the recommended spacing in the table should be increased.
  - If the cable are laid inside conduits then the following point must also be taken into account when grouping various cable together for introduction into the conduits
  - Power cable(including power supply to air conditioner) and communication cables must not be laid inside the same
  - In the same way, when grouping the power wires and communication cables should not be bunched together.

### CAUTION

If apparatus is not properly earthed then there is always a risk of electric shock, the grounding of the apparatus must be carried out by a qualified person.

## Wiring of main power supply and equipment capacity

- Use a separate power supply for the Outdoor Unit and Indoor Unit.
- Bear in mind ambient conditions (ambient temperature, direct sunlight, rain water, etc.) when proceeding with the wiring and connections.
- The cable size is the minimum value for metal conduit wiring. The power cord size should be 1 rank thicker taking into account the line voltage drops. Make sure the power-supply voltage does not drop more than 10 %.
- Specific wiring requirements should adhere to the wiring regulations of the region.
- Power supply cords of parts of appliances for outdoor use should not be lighter than polychloroprene sheathed flexible cord.
- Don't install an individual switch or electrical outlet to disconnect each of indoor unit separately from the power supply.

### ⚠ WARNING

- Follow ordinance of your governmental organization for technical standard related to electrical equipment, wiring regulations and guidance of each electric power company.
- Make sure to use specified cables for connections so that no external force is imparted to terminal connections. If connections are not fixed firmly, it may cause heating or fire.
- Make sure to use the appropriate type of overcurrent protection switch. Note that generated overcurrent may include some amount of direct current.

### ⚠ CAUTION

- All installation site must require attachment of an earth leakage breaker. If no earth leakage breaker is installed, it may cause an electric shock.
- Do not use anything other than breaker and fuse with correct capacity. Using fuse and wire or copper wire with too large capacity may cause a malfunction of unit or fire.

## Field Wiring

### Single outdoor unit

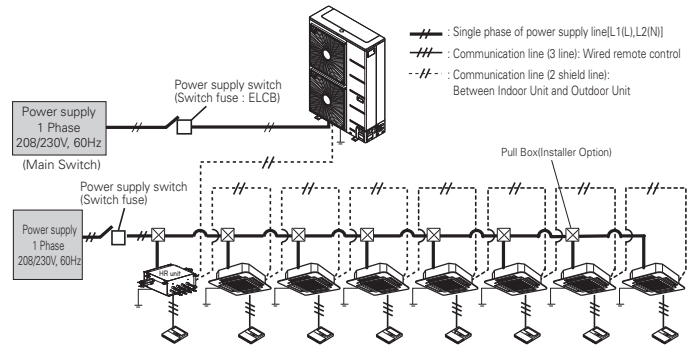

### ⚠ WARNING

- Indoor unit ground lines are required for preventing electrical shock accident during current leakage, Communication disorder by noise effect and motor current leakage (without connection to pipe).
- Don't install an individual switch or electrical outlet to disconnect each of indoor unit separately from the power supply.
- Install the main switch that can interrupt all the power sources in an integrated manner because this system consists of the equipment utilizing the multiple power sources.
- If there exists the possibility of reversed phase, lose phase, momentary blackout or the power goes on and off while the product is operating, attach a reversed phase protection circuit locally. Running the product in reversed phase may break the compressor and other parts.
- When using shielded wires, perform a single-point grounding only to the outdoor unit for grounding of communication wires.

### Example) Connection of transmission wire

#### [BUS type]

- Connection of communication cable must be installed like below figure between indoor unit to outdoor unit.

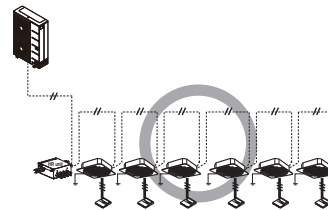

#### [STAR type]

- Abnormal operation can be caused by communication defect, when connection of communication cable is installed like below figure (STAR type).

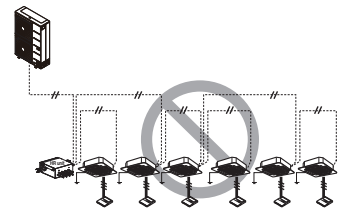

Example) Connection of power and communication cable

ARUB\*\*\*GSS4  
5 Ton

ARUM\*\*\*GSS5  
3, 4 Ton

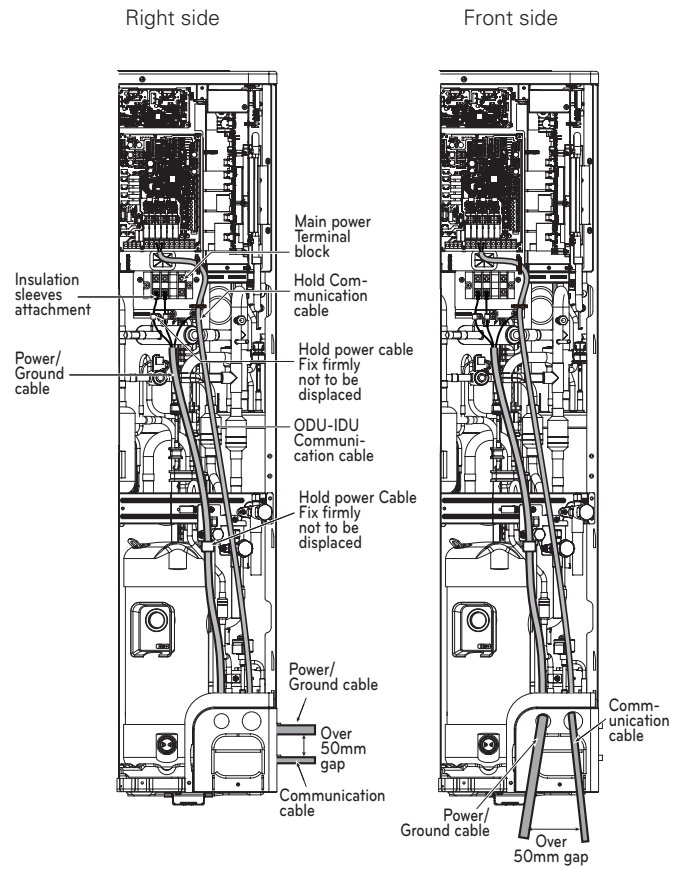
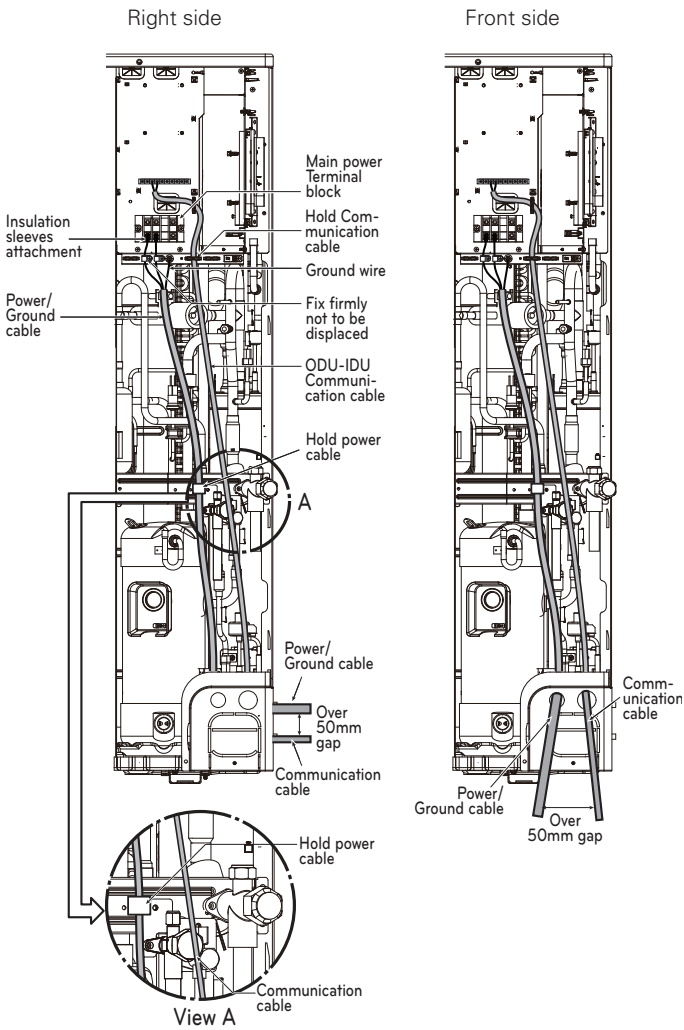

## Checking the setting of outdoor units

### Checking according to DIP switch setting

- You can check the setting values of the Master outdoor unit from the 7 segment LED.  
The DIP switch setting should be changed when the power is OFF.

### Checking the initial display

The number is sequentially appeared at the 7 segment in 5 seconds after applying the power. This number represents the setting condition.

### Service PCB

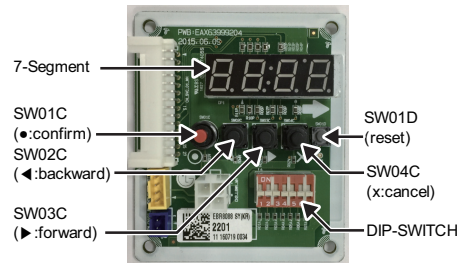

- Communication speed setting  
The factory setting of DIP switch 3 differs depending on production date.  
- Set the DIP switch 3 to "On" if all the indoor units are "ARN\*\*\*\*\*4".  
- Set the DIP switch 3 to "Off" if not all the indoor units are "ARN\*\*\*\*\*4".

## CAUTION

1. Set the DIP switch No. 3 "On" and if not all the indoor units are "ARN\*\*\*\*\*4" connected, normal communication is impossible, so DIP switch No. 3 must be set to "Off".
2. When changing DIP switch, all power should be off and auto addressing must be executed.

DIP switch No. 3	Off	On
Comm. Speed	1200 bps	9600 bps

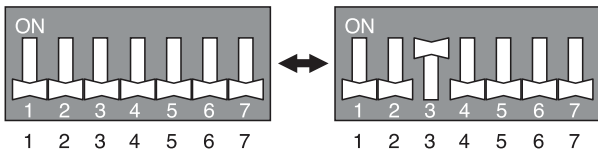
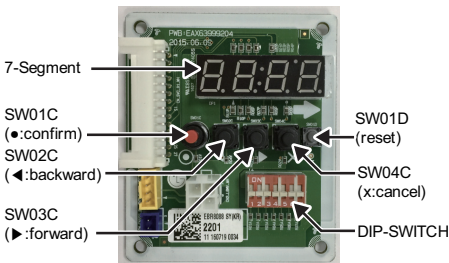

### Initial display order

Order	No	Note
①	4~12	Model capacity
	1	Cooling only
②	2	Heat pump
	3	Heat Recovery
③	22	220V
④	1	Standard
	5	Cold Area

### Example) ARUM048GSS5

①	②	③	④
05	3	22	5

## CAUTION

Be sure to turn off outdoor unit power before installation.

### \* Heat Pump installation

- ① Turn on the DIP s/w No 4.

DIP switch setting	ODU Setting
	Setting Heat pump system or Heat Recovery system (Installer Setting)

- ② The factory setting display is appeared "HR".
- ③ Change "HR" into "HP" display pushing ► button and then push confirm button.
- ④ Turn off the DIP s/w No 4. and Push reset button to restart the system. (If you turn on the DIP s/w No 4, you can make sure "HR" or "HP" display later.)

## Setting For Heat Recovery Unit (Refer Only Heat Recovery Installation)

### [Heat Recovery (HR) Unit Board]

#### 2 Series

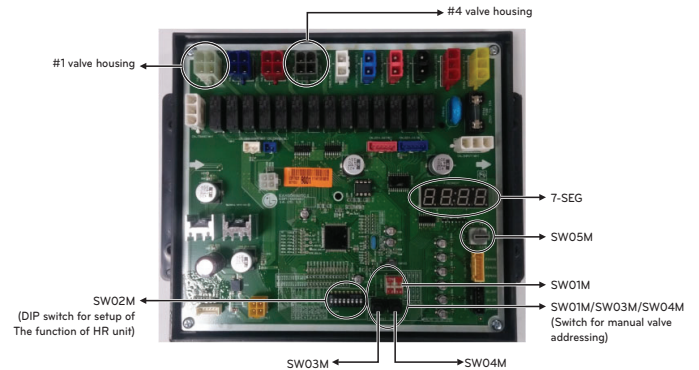

#### 3 Series

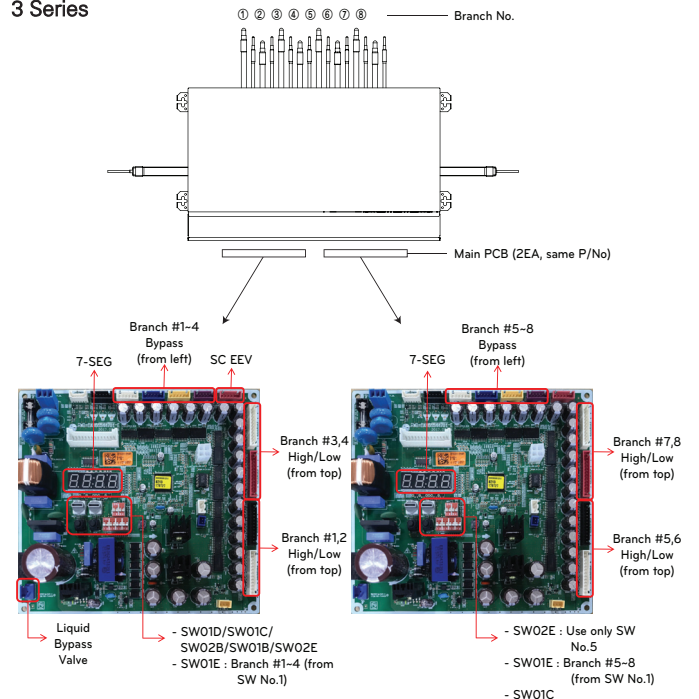

\* Number from left in sequence for less-than-8 branch model.

\*\* PRHR043A / PRHR033A / PRHR023A : Master Only

## Switch for setup of HR Unit

### 2 Series



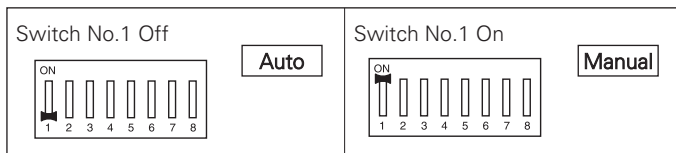

#### Main function of SW02M

 SW02M	ON S/W	Selection	
	No.1	Method for addressing valves of an HR unit (Auto/Manual)	
	No.2	Model of HR unit	
	No.3	Model of HR unit	
	No.4	Model of HR unit	
	No.5	Valve group setting	
	No.6	Valve group setting	
	No.7	Use only in factory production (preset to "OFF")	Zoning setting ("ON")
No.8	Use only in factory production (preset to "OFF")		

#### 1 Selection of the method for addressing valves of an HR unit (Auto/Manual)

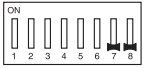

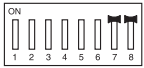

#### 2 Setting the zoning control

	DIP Switch setting	
Normal control		 SW01M
Zoning control		 SW01M Turn the DIP switch of the zoning branch on. Ex) Branch 1,2 are zoning control.

\* Zoning control  
This function is used to connect multiple indoor units to one pipe.

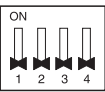
### 3 Series







	SW	Function
DIP SW	 SW02E (8pin DIP SW)	Selection of the method for pipe detection Selection of Master/Slave Main PCB Setting the Zoning Control Selection of the No. of connected branches
	 SW01E (4pin DIP SW)	Selection of the valve to address
Rotary SW		SW01D (Left) Selection of the Valve Group Control
		SW01C (Right) Manual addressing of zoning indoor units Setting to address HR units
Push SW		SW02B (Left) Increase in the digit of 10
		SW01B (Right) Increase in the digit of 1

#### Main function of SW02E

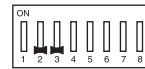
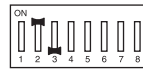
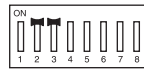
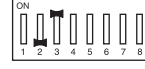
ON S/W	Selection	
No.1	Method for pipe detection of an HR Unit (Auto/Manual)	
No.2	No. of connected branches	
No.3		
No.4		
No.5	Master/Slave (Main PCB) Setting	
No.6	EEPROM factory initialization (4,5,6)	
No.7	Use only in factory production (preset to "OFF")	Zoning setting ("ON")
No.8	Use only in factory production (preset to "OFF")	

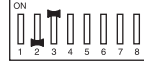
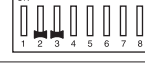
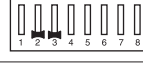
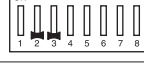
#### 3 Selection of the model of HR unit

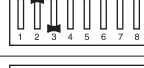
### 2 Series

	(For 2 branches) PRHR022A	(For 3 branches) PRHR032A	(For 4 branches) PRHR042A
Initial Setting			
1 branches Connected			
2 branches Connected			
3 branches Connected			
4 branches Connected			

\* Each model is shipped with the switches No.2 and No.3 pre-adjusted as above in the factory.

### ! WARNING

- If you want to use a PRHR032A for 2 branches HR unit after closing the 3rd pipes, set the DIP switch for 2 branches HR unit.
- If you want to use a PRHR042A for 3 branches HR unit after closing the 4th pipes, set the DIP switch for 3 branches HR unit.
- If you want to use a PRHR042A for 2 branches HR unit after closing the 3rd and 4th pipes, set the DIP switch for 2 branches HR unit.
- The unused port must be closed with a copper cap, not with a plastic cap.

3 Series

	PRHR023A	PRHR033A	PRHR043A
1 branch Connected			
2 branch Connected			
3 branch Connected			
4 branch Connected			
5 branch Connected			
6 branch Connected			
7 branch Connected			
8 branch Connected			

	PRHR063A	PRHR083A
1 branch Connected		
2 branch Connected		
3 branch Connected		
4 branch Connected		
5 branch Connected		
6 branch Connected		
7 branch Connected		
8 branch Connected		

4 Setting the Valve Group.

2 Series

	DIP S/W setting	Example
Not control		
No.1, 2 Valve Control		
No.2, 3 Valve Control		
No.3, 4 Valve Control		
No.1, 2 Valve / No.3, 4 Valve Control		

\* Setting the Valve Group

This function is used to connect one indoor unit to two pipes. (Large capacity indoor unit over 56 kBtu must be connected to two pipes.)

**NOTE**

If the large capacity indoor units are installed, below Y branch pipe should be used.

**Y branch pipe**

\* For more information, refer accessory installation manual.

(Unit: mm [inch])

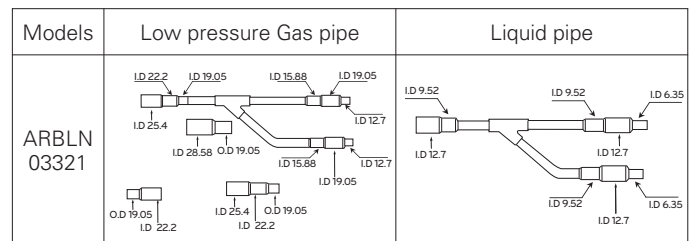

**WARNING**

If you want to use a "Model" for "No. of using branch(es)" HR Unit after closing the "Closing pipe No.", set the DIP switch for "No. of using branch(es)" HR Unit.

Ex) If you want to use a PRHR083A for 4 branches HR Unit after closing the 5~8th pipes, set the DIP switch for 4 branches HR Unit.

**SW05M (Rotary S/W for addressing HR unit)**

Must be set to '0' when installing only one HR unit.  
When installing multiple HR units, address the HR units with sequentially increasing numbers starting from '0'.

Ex) Installation of 3 HR units

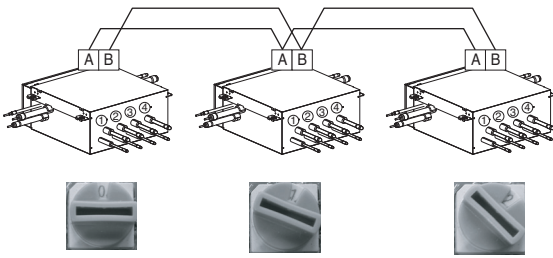

**SW01M/SW03M/SW04M (DIP S/W and tact S/W for manual valve addressing)**

1 Normal setting (Non-Zoning setting)

- Set the address of the valve of the HR unit to the central control address of the connected indoor unit.
- SW01M: selection of the valve to address  
SW03M: increase in the digit of 10 of valve address  
SW04M: increase in the last digit of valve address
- Prerequisite for manual valve addressing : central control address of each indoor unit must be preset differently at its wired remote control.

	S/W No.	Setup
	No.1	Manual addressing of valve #1
	No.2	Manual addressing of valve #2
	No.3	Manual addressing of valve #3
	SW03M	Increase in the digit of 10 of valve address
	SW04M	Increase in the last digit of valve address

2 Zoning setting

- Set the address of the valve of the HR unit to the central control address of the connected indoor unit.
- SW01M : selection of the valve to address  
SW03M : increase in the digit of 10 of valve address  
SW04M : increase in the last digit of valve address  
SW05M :Rotary S/W
- Prerequisite for manual valve addressing : central control address of each indoor unit must be preset differently at its wired remote control.

	S/W No.	Setup
	No.1	Manual addressing of valve #1
	No.2	Manual addressing of valve #2
	No.3	Manual addressing of valve #3
	SW03M	Increase in the digit of 10 of valve address
	SW04M	Increase in the last digit of valve address
	SW05M	Manual addressing of zoning indoor units

**3 Series**

**Main function of SW01D**

1) Selection of the Valve Group Control.

**NOTE**

Use the Valve Group Control when 2 branches are connected with only 1 indoor unit which has higher capacity than 61 kBtu.

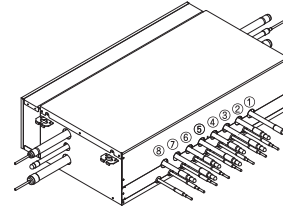

\* Master Only

Valve Group	SW01D Setting	Valve Group	SW01D Setting
Not control	0	No. 5,6/7,8 Valve Control	8
No. 1,2 Valve Control	1	No. 1,2/5,6 Valve Control	9
No. 2,3 Valve Control	2	No. 1,2/7,8 Valve Control	A
No. 3,4 Valve Control	3	No. 3,4/5,6 Valve Control	B
No. 5,6 Valve Control	4	No. 3,4/7,8 Valve Control	C
No. 6,7 Valve Control	5	No. 1,2/3,4/5,6 Valve Control	D
No. 7,8 Valve Control	6	No. 1,2/3,4/6,7 Valve Control	E
No. 1,2/3,4 Valve Control	7	No. 1,2/3,4/7,8 Valve Control	F

**NOTE**

If the large capacity indoor units are installed, below Y branch pipe should be used.

**\* Y branch pipe**

\* For more information, refer accessory installation manual.

[Unit : mm(inch)]

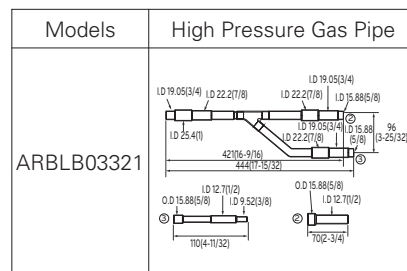
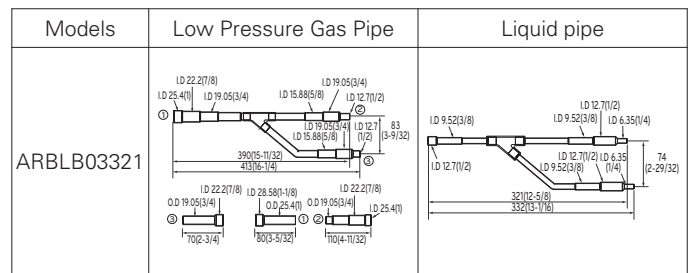

### SW01C (Rotary S/W for addressing HR unit)

Must be set to '0' when installing only one HR unit.  
 When installing multiple HR units, address the HR units with sequentially increasing numbers starting from '0'.  
 Maximum 16 HR Units can be installed.

Ex) Installation of 3 HR units

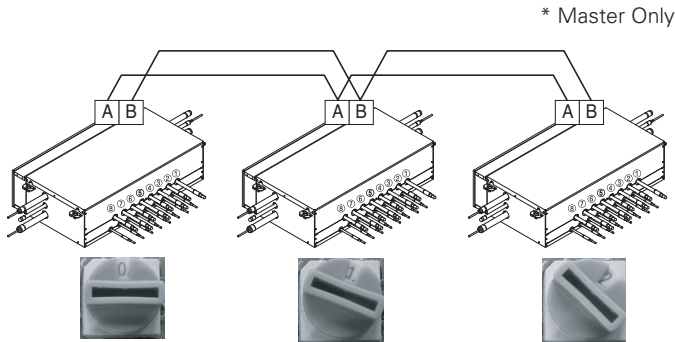

### SW01B/SW01C/SW01E/SW02B (DIP S/W and push S/W for Manual pipe detection)

- Set the address of the valve of the HR unit to the central control address of the connected indoor unit.
- SW01E: selection of the valve to address
- SW02B: increase in the digit of 10 of valve address
- SW01B: increase in the last digit of valve address
- SW01C: Manual addressing of zoning indoor units (use for Zoning setting)
- Prerequisite for Manual pipe detection : central control address of each indoor unit must be preset differently at its wired remote control.

	S/W No.	Setup
 SW01E	No.1	Manual addressing of valve #1 (Master) / #5 (Slave)
	No.2	Manual addressing of valve #2 (Master) / #6 (Slave)
	No.3	Manual addressing of valve #3 (Master) / #7 (Slave)
	No.4	Manual addressing of valve #4 (Master) / #8 (Slave)
 SW02B	SW02B	Increase in the digit of 10 of valve address
 SW01B	SW01B	Increase in the last digit of valve address
* Use for Zoning setting  SW01C	SW01C	Manual addressing of zoning indoor units

### 1 Normal setting (Non-Zoning setting)

ex) Manual pipe detection of Valve #1, 6.

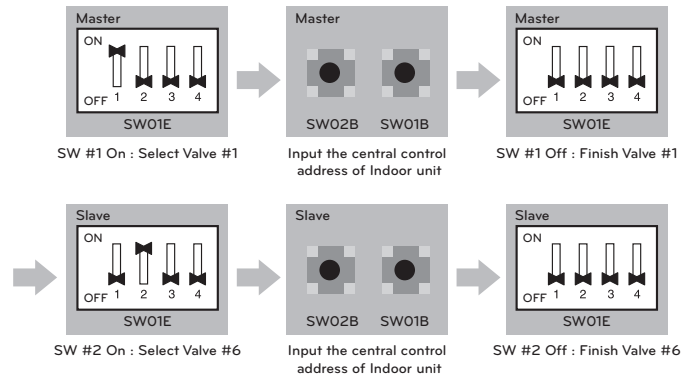

### 2 Zoning setting

#### NOTE

Use the Zoning Control when install two or more indoor units at 1 branch of HR Unit.  
 The indoor units controlled by Zoning Control can be selected collectively as the cooling / heating mode.

ex) Manual pipe detection of Valve #5 with three zoning indoor units, #6 without zoning unit.

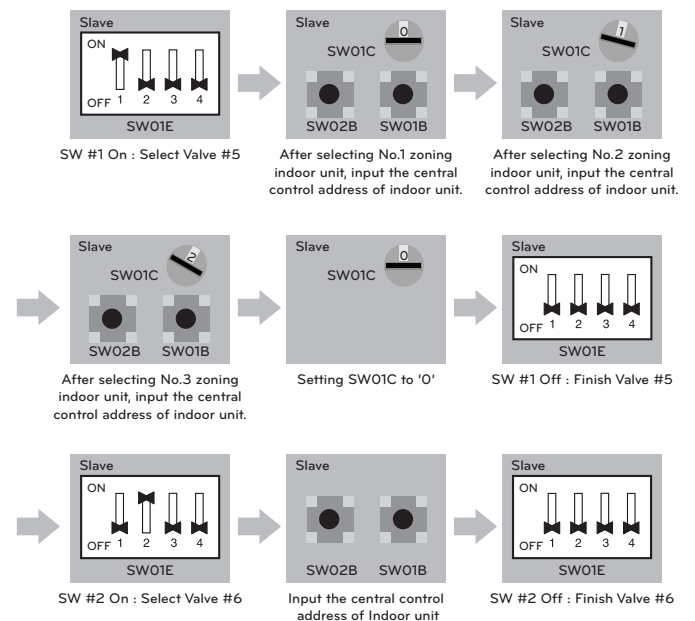

## Automatic Addressing

### The address of indoor units would be set by Automatic Addressing

- Wait for 3 minutes after supplying power. (Master and Slave outdoor units, indoor units)
- Press RED button of the outdoor units for 5 seconds. (SW01C)
- A "88" is indicated on 7-segment LED of the outdoor unit PCB.
- For completing addressing, 2~7 minutes are required depending on numbers of connected indoor units
- Numbers of connected indoor units whose addressing is completed are indicated for 30 seconds on 7-segment LED of the outdoor unit PCB
- After completing addressing, address of each indoor unit is indicated on the wired remote control display window. (CH01, CH02, CH03, ....., CH06 : Indicated as numbers of connected indoor units)

### SERVICE PCB

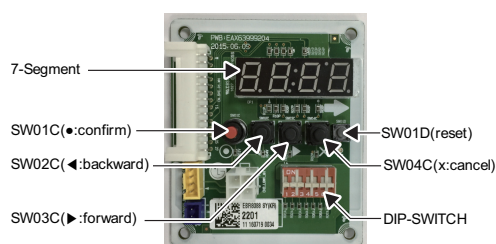

### The Procedure of Automatic Addressing

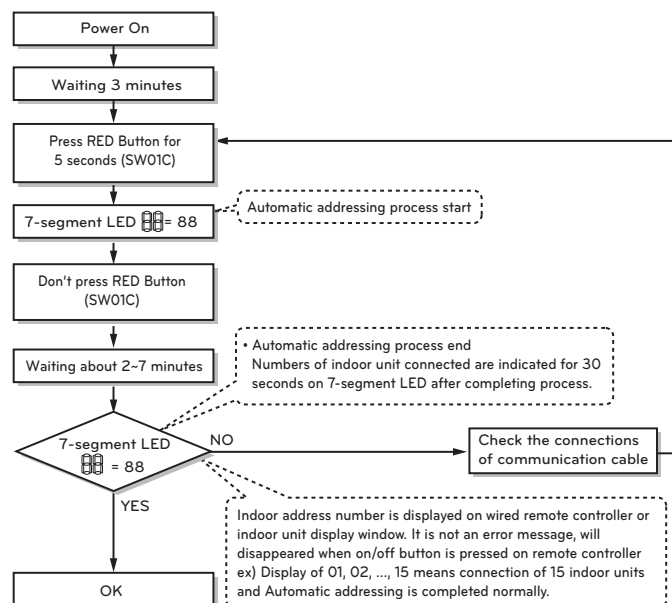

### CAUTION

- In replacement of the indoor unit PCB, always perform Automatic addressing setting again (At that time, please check about using Independent power module to any indoor unit.)
- If power supply is not applied to the indoor unit, operation error occur.
- Automatic Addressing has to be performed after more than 3 minutes to improve indoor unit communication when initial power is supplied.
- Please be sure that all the DIP switch (1~7) of master outdoor unit is OFF before Automatic Addressing setting

### Setting For Heat Recovery Unit (Refer Only Heat Recovery Installation)

#### Automatic pipe detection

- 1 Turn No.1 of DIP s/w SW02E of HR unit PCB off.
- 2 Confirm that the setting of No.2, 3 of SW02E corresponds with the type of the valve connection.
- 3 Reset the power of HR unit PCB
- 4 Master Outdoor unit PCB DIP switch on : No.5
- 5 Select the mode using '▶', '◀' Button : "Idu" Push the '●' button
- 6 Select the "Id 5" function using '▶', '◀' Button : "Atc" or "Ath" Push the '●' button.  
Outdoor temperature is over 15 °C(59 °F) : "Ath" Using (If it fail, use "Atc")  
Outdoor temperature is below 15 °C(59 °F) : "Atc" Using (If it fail, use "Ath")
- 7 Select the mode using '▶', '◀' Button : "Idu" Push the '●' button
- 8 Select the "Id 6" function using '▶', '◀' Button : "StA" Push the '●' button
- 9 System is operated after "88" is displayed on 7 segment of the outdoor unit main PCB.
- 10 Pipe detection process is proceeded.
- 11 5~30 minutes are required depending on the number of the indoor units and outdoor temperature.
- 12 The number of the indoor units connected is displayed on 7 segment of the outdoor unit main PCB for about 1 minute  
- For a HR unit, the number of the indoor units connected to each HR unit is displayed.  
- '200' is displayed in case of auto pipe detecting error, and Auto pipe detection process is completed after '88' is disappeared.  
\* Auto pipe detection function : the function that sets connection relationship automatically between the indoor unit and HR unit.

### WARNING

- Execute auto addressing and auto pipe detection again whenever the indoor PCB and HR unit PCB is replaced.  
- Operation error occurs unless power is supplied to the indoor and HR units.
- Error No.200 occurs if the number of connected indoor units and that of scanned indoor units are different.
- If auto pipe detection process fails, complete it with manual pipe detection (see Manual pipe detection part).
- If auto pipe detection process is completed normally, manual pipe detection is not required.
- If you want to do auto pipe detection again after auto pipe detection fails, do after reset of outdoor unit by all means.
- During 5 minutes after pipe detection is completed, do not turn off the main unit PCB to save the result of pipe detection automatically.

#### Manual pipe detection

- 1 Enter the central control address into each indoor unit using its wired remote controller.
- 2 Turn No.1 of DIP s/w SW02E of HR unit PCB on.
- 3 Reset the power of HR unit PCB.
- 4 On the HR unit PCB, manually set address of each valve of the HR unit to the central control address of the indoor unit connected to the valve.
- 5 Reset the power of outdoor unit PCB.
- 6 The number of the indoor unit installed is displayed after about 5 minutes.  
Ex) HR → The number of the indoor
- 7 Reset the power of outdoor unit PCB, HR unit.
- 8 Manual pipe detection is completed

## ! WARNING

- In case that central controller is not installed, firstly set up central controller's setting to make address setting of indoor units.
- In case that central controller is installed, please set central control address in wired remote control of indoor unit.
- Do not set central control address of indoor unit to '0xFF'. (If the address is '0xFF', pipe detection will not be completed properly.)
- HR units's manual pipe address is set by the central control address of indoor units.
- Address of valve which is not connected with indoor unit should be set differently with the address of a valve which is indoor unit connected. (If address is overlapped, valve will not work properly)
- If there occurs some error during pipe detection process, it means pipe detection process is not properly finished.
- If an error occurred, it means that manual pipe setting is not completed.
- During 5 minutes after pipe detection process is completed, do not turn off the main outdoor unit's PCB to save the result of pipe detection automatically.

## Flow chart of auto pipe detection Process

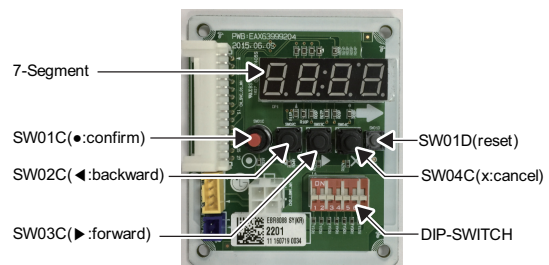
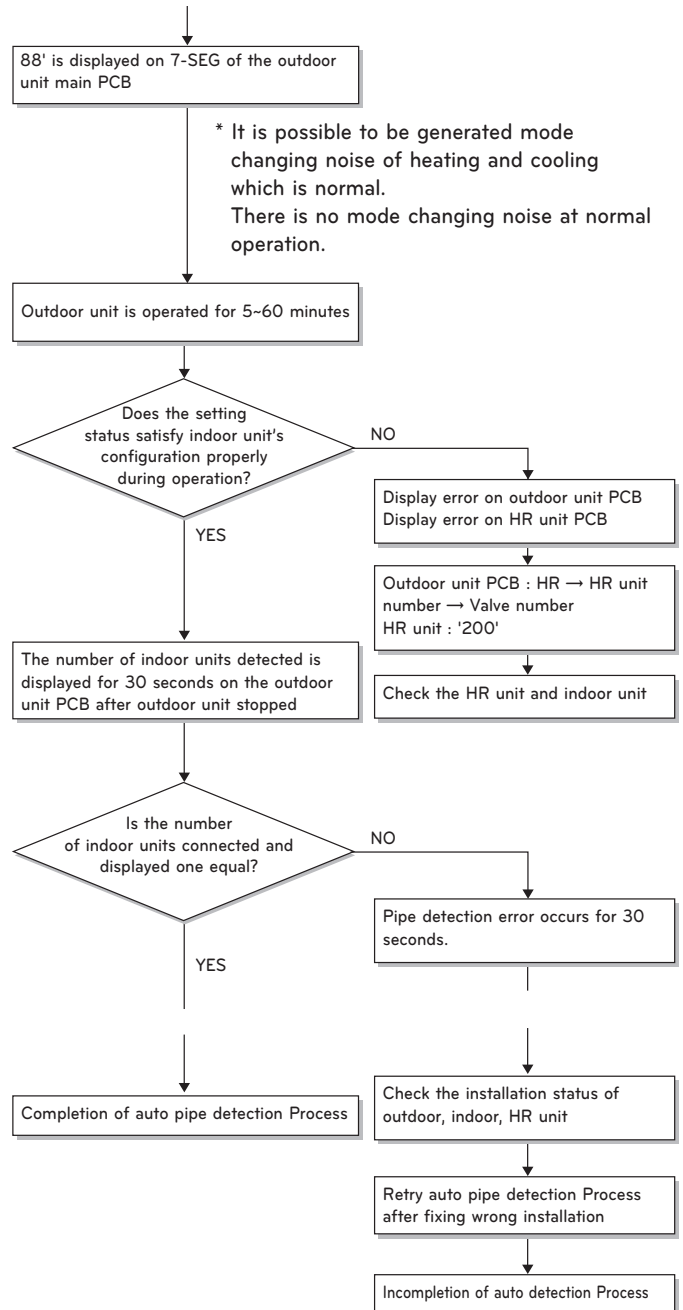
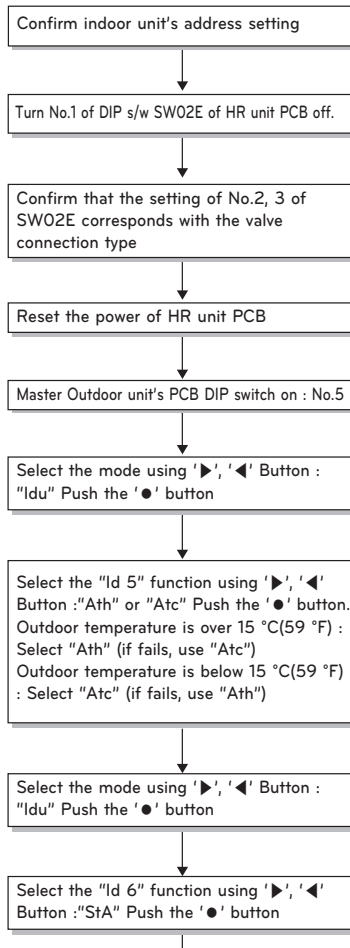

## Flow chart of manual addressing for pipe detection

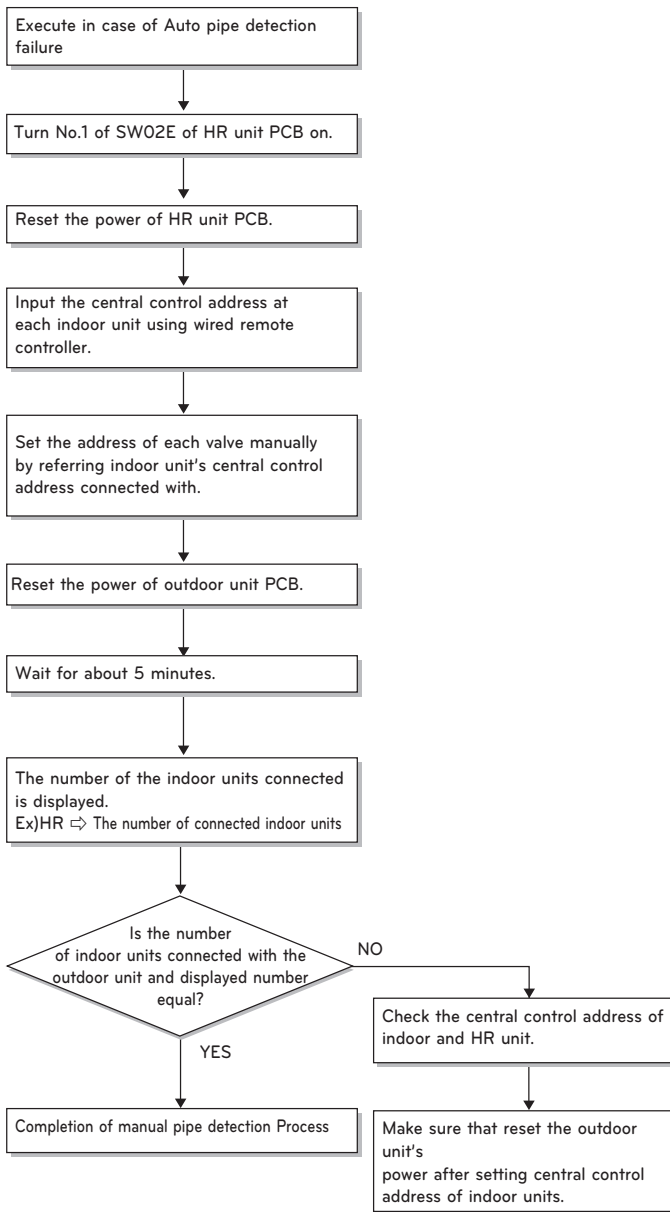

## Example of manual valve addressing (Non-Zoning setting)

(In case that an indoor unit of central control address "11" is connected to a valve #1 of an HR unit)

- Prerequisite for manual valve addressing: central control address of each indoor unit must be preset differently at its wired remote control.

No.	Display and setup	Setup and Contents
1		- Operation: None - Display: None
2		- Operation: Turn DIP S/W No.1 on to address valve #1 - Display: Existing value saved in EEPROM is displayed in 7-SEG.
3		- Operation: Set the digit of 10 to the number in Group High data of the wired remote control connected to the corresponding indoor unit to the valve #1 by pressing left tack S/W. - Display: Digit increasing with the times of pressing tack S/W is displayed in left 7-SEG
4		- Operation: Set the digit of 1 to the number in Group Low data of the wired remote control connected to the corresponding indoor unit to the valve #1 by pressing right tack S/W. - Display: Digit increasing with the times of pressing tack S/W is displayed in right 7-SEG
5		- Operation: Turn DIP S/W No.1 off to save the address of valve #1 - Display: "11" displayed in 7-SEG disappears

- Above setup must be done for all HR unit valves.

- The valve that is not connected with any indoor unit should be addressed with any other number than used address numbers of the valves connected with indoor units.

(The valves does not work if the address numbers are same.)

## Example of manual valve addressing (Zoning setting)

(In case that an indoor unit of central control address "11" is connected to a valve #1 of an HR unit)

Zoning control is connecting 2 or more indoor units at one pipe of HR unit. In case of Zoning control, in order to set controls with multiple indoor units connection uses the rotary switch. Namely, only the rotary switch changes from same valve set condition and set indoor units connection.

- 1 On DIP switch of the corresponding valves and sets the rotary switch at 0.
- 2 Setting the number with tact switch.
- 3 In case of addition of indoor units to same port, increases 1 with the rotary switch and sets number with tact switch.
- 4 In case of checking the number which the corresponding valve is stored, turn on DIP switch and set the number of rotary switch.
- 5 Indoor units set available 7 per a port(rotary switch 0~6), in case of setting above of 7 with rotary switch, it will display error.
- 6 Setting the rotary switch on original condition(HR unit number set conditions) after all finishing a piping setting.
- 7 The rotary switch set value of above number of indoor units which is connected with FF and prevents a malfunction.  
(Example: The case where 3 indoor units is connected in piping 1, sets from rotary switch 0,1,2 and 3,4,5 with FF set)  
- Prerequisite for manual valve addressing: central control address of each indoor unit must be preset differently at its wired remote control.

No.	Display and setup	Setup and Contents
1		- Operation: None - Display: None
2		- Operation : Turn dip S/W No.1 on to address valve #1 - Display : Existing value saved in EEPROM is displayed in 7-SEG.
3		- Operation : Set the digit of 10(1) to the number in Group High data of the wired remote control connected to the corresponding indoor unit to the valve #1 by pressing left tact S/W. - Display : Digit increasing with the times of pressing tact S/W is displayed in left 7-SEG.
4		- Operation : SW01C : 1 - Display : Display former value.
5		- Operation : Setting No. using SW02B and SW01B, SW01C : 1 - Display : Display setting value.
6		- Operation : Turn dip S/W No.1 off to save the address of valve #1 - Display : "11" displayed in 7-SEG disappears.
7		- Operation : Return valve of addressing HR unit. - Display : None

- Above setup must be done for all HR unit valves.
- The valve that is not connected with any indoor unit should be addressed with any other number than used address numbers of the valves connected with indoor units.  
(The valves does not work if the address numbers are same.)

## Method of checking the pipe detection result at HR unit

In case that an indoor unit of central control address "11" is connected to a valve #1 of an HR unit

No.	Display and setup	Setup and Contents
1		- Operation: Turn DIP S/W No.1 on. - Display: "11" is displayed in 7-SEG
2		- Operation: Turn DIP S/W No.1 off - 7-SEG disappeared

## Identification of Manual Valve ID (Address)

No.	Display and setup	Setup and Contents
1		- Operation: more than 2 DIP switches turned on. - Display: "Er" is displayed in 7-SEG

## Method of checking the pipe detection result at outdoor unit

- 1 Wait for 5 minutes, after Pipe detection is completed.
- 2 Turn on the No.10,14,16 DIP S/W of SUB PCB at master unit
- 3 Check the data on 7- segment, switching rotary 01,02.

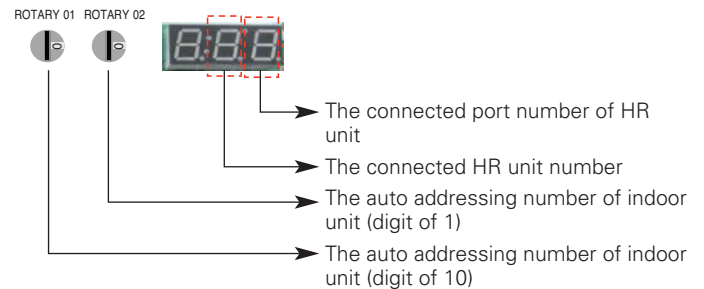

## Setting method of Master indoor unit in zoning

- 1 Turn DIP switch 5,6,10 on at system off.
- 2 Set the left Rotary switch for HR unit.(Rotary switch No. "0" ' HR unit No. "1")
- 3 Set the right Rotary switch for IDU unit.(Rotary switch No. "0" ' HR unit branch No. "1")
- 4 Display the Master IDU No. of the HR unit on 7segment.(Default display is "00" on 7segment)
- 5 Press the black button.(The IDU No. increase every 1 second in the zoning )
- 6 Set the Master IDU.(Press the red button during 1.5 seconds stop twinkling)

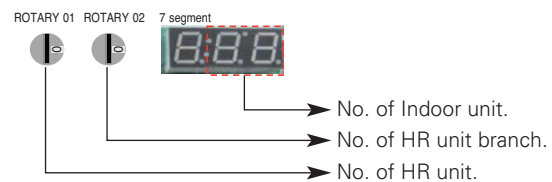

## CAUTION

- Waiting for 80 seconds after power on.
- The zoning information and Master IDU information remove from EEPROM after Auto-addressing.
- If there is installed the central control, it is impossible setting of Master IDU in zoning.

## Group Number setting

### Group Number setting for Indoor Units

- Confirm the power of whole system(Indoor Unit, Outdoor Unit) is OFF, otherwise turn off.
- The communication cables connected to CEN.A and CEN.B terminal should be connected to central control of Outdoor Unit with care for their polarity (A-A, B-B).
- Turn the whole system on.
- Set the group and Indoor Unit number with a wired remote control.
- To control several sets of Indoor Units into a group, set the group ID from 0 to F for this purpose.

### Outdoor Units (Main PCB)

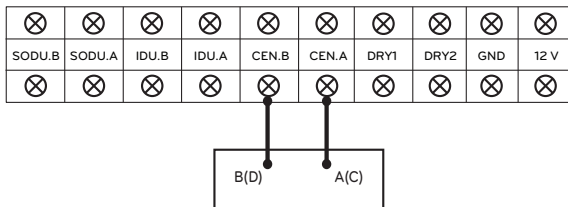

Example) Group number setting

1 E

Group Indoor unit

1<sup>st</sup> number indicate the group number

2nd number point out indoor unit number

Group recognizing the central controller	
No.0 group (00~0F)	
No.1 group (10~1F)	
No.2 group (20~2F)	
No.3 group (30~3F)	
No.4 group (40~4F)	
No.5 group (50~5F)	
No.6 group (60~6F)	
No.7 group (70~7F)	
No.8 group (80~8F)	
No.9 group (90~9F)	
No. A group (A0~AF)	
No. B group (B0~BF)	
No. C group (C0~CF)	
No. D group (D0~DF)	
No. E group (E0~EF)	
No. F group (F0~FF)	

### WARNING

- Valve address and central control address of its corresponding indoor unit should be set identical in manual addressing.

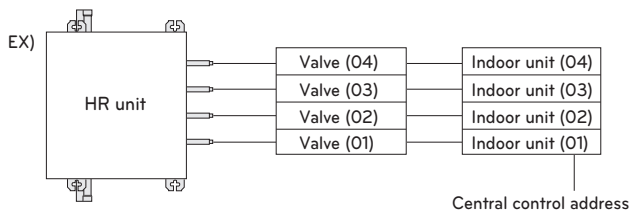

### Setting the optional function

Select the mode/function/option/value using '▶', '◀' Button and confirm that using the '●' button after DIP switch No.5 is turned on.

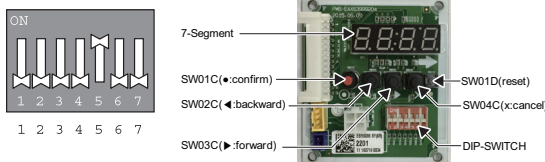

Mode	Function		Option		Value		Action		Remarks		
	Content	Display1	Content	Display2	Content	Display3	Content	Display4		Implement	Display5
Installation	Func	Cool & Heat Selector	Fn1	oFF	op1~op2	Selected the option	-	-	Change the set value	Blank	Save in EEPROM
		Static pressure compensation	Fn2	oFF	op1	Selected the option	-	-	Change the set value	Blank	Save in EEPROM
		Night low noise	Fn3	oFF	op1~op15	Selected the option	-	-	Change the set value	Blank	Save in EEPROM
		ODU address	Fn5	-	-	-	0~255	set the value	Change the set value	Blank	Save in EEPROM
		Snow removal & rapid defrost	Fn6	oFF	op1~op3	Selected the option	-	-	Change the set value	Blank	Save in EEPROM
		Target pressure adjusting	Fn8	oFF	op1~op7	Selected the option	-	-	Change the set value	Blank	Save in EEPROM

\* Functions save in EEPROM will be kept continuously, though the system power was reset.

\* Dip switch 3 can be OFF except when installing the only 4 series indoor units (named ARNU\*\*\*4).

### CAUTION

- To perform the optional function should be sure that All the IDU is off mode, unless the function will not be performed.

## Cool & Heat selector (Fn 1)

### Mode setting method

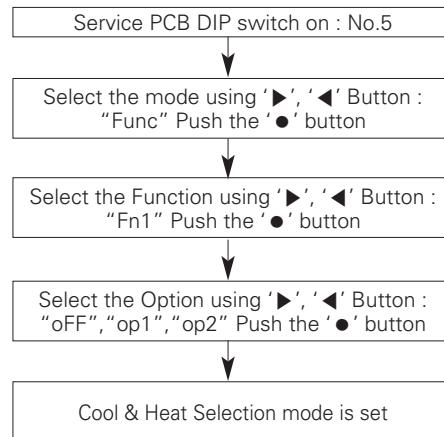

### Function setting

Switch Control		Function		
Switch (Up)	Switch (Down)	oFF	op1(mode)	op2(mode)
Right side (On)	Left side (On)	Not operate	Cooling	Cooling
Right side (On)	Right side (On)	Not operate	Heating	Heating
Left side (Off)	-	Not operate	Fan mode	Off

Left side | Right side

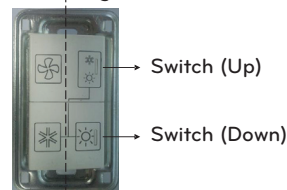

### CAUTION

- Ask an authorized technician to setting a function.
- If do not use a function, set an off-mode.
- If use a function, first install a Cool & Heat selector.

## High Static Pressure Compensation mode (Fn 2)

This function secures the air flow rate of ODU, in case static pressure has been applied like using duct at fan discharge of ODU.

### Static pressure compensation mode setting method

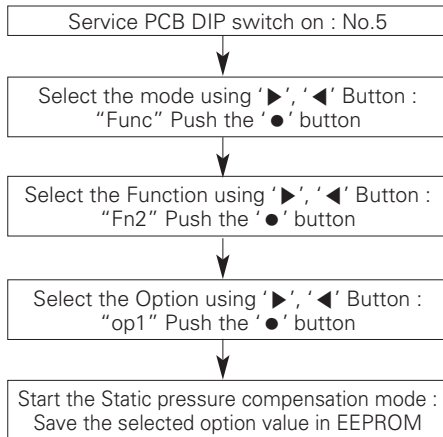

### FAN Maximum RPM of each step

#### ARUB\*\*\*GSS4

System(Ton)		5
Max.RPM	Op1	850
	Op2	850
	Op3	1000

#### ARUM\*\*\*GSS5

System(Ton)		3,4
Max.RPM	Op1	750

## Night Low Noise Function (Fn 3)

In cooling mode, this function makes the ODU fan operate at low RPM to reduce the fan noise of ODU at night which has low cooling load.

### Night low noise function setting method

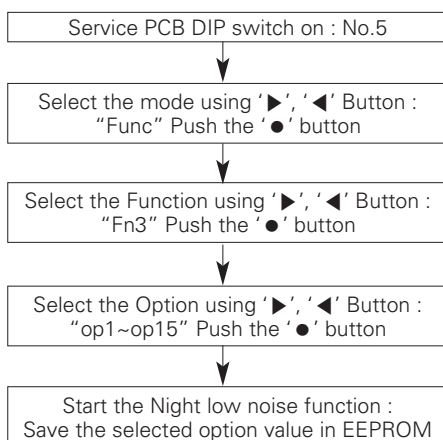

### Time Settings

Step	Judgement Time(Hr)	Operation Time(Hr)
op1	8	9
op2	6.5	10.5
op3	5	12
op4	8	9
op5	6.5	10.5
op6	5	12
op7	8	9
op8	6.5	10.5
op9	5	12
op10	continuous operation	
op11	continuous operation	
op12	continuous operation	
op13	6.5	10.5
op14	6.5	10.5
op15	6.5	10.5

### CAUTION

- Request installer to set the function during installation.
- If ODU RPM changes, cooling capacity may go down.

## Setting the ODU address (Fn 5)

### Mode setting method

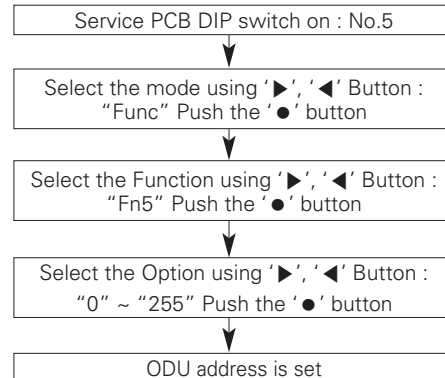

### CAUTION

- Ask an authorized technician to setting a function.
- If use a function, first install a Central controller.

## Snow removal & rapid defrost (Fn 6)

### Mode setting method

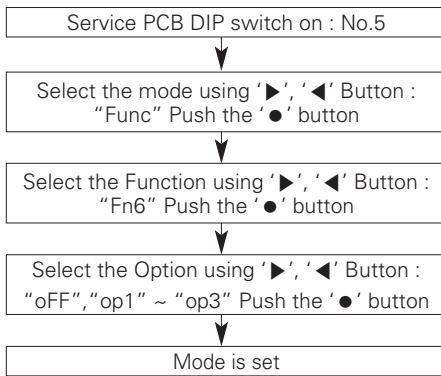

### Mode setting

setting	Mode
oFF	Not setting
op1	Snow removal mode
op2	Rapid defrost mode
op3	Snow removal mode. + Rapid defrost mode.

### CAUTION

- Ask an authorized technician to setting a function.
- If do not use a function, set an off-mode.

## Target pressure adjusting (Fn 8)

### Mode setting method

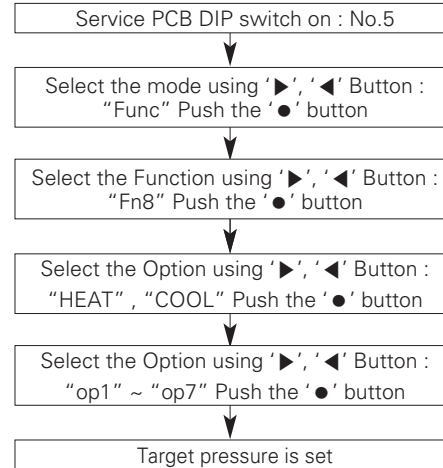

### Setting

Mode	Low Pressure (kPa)	High Pressure (kPa)
oFF	804	2990
op1	699	3121
op2	739	2827
op3	843	2696
op4	908	2565
op5	961	2435
op6	1026	2304
op7	804	2990

### CAUTION

- Ask an authorized technician to setting a function.
- If do not use a function, set an off-mode.
- Change a power consumption or capacity.

## Self-Diagnosis Function

### Error Indicator

- This function indicates types of failure in self-diagnosis and occurrence of failure for air condition.
- Error mark is displayed on display window of indoor units and wired remote controller, and 7-segment LED of outdoor unit control board as shown in the table.
- If more than two troubles occur simultaneously, lower number of error code is first displayed.
- After error occurrence, if error is released, error LED is also released simultaneously.

### Error Display

1st,2nd,3rd LED of 7-segment indicates error number, 4th LED indicates unit number.



\* Refer to the Indoor manual for some Indoor Error code.

Display			Title	Cause of Error	
Indoor unit related error	0	1	-	Air temperature sensor of indoor unit	Air temperature sensor of indoor unit is open or short
	0	2	-	Inlet pipe temperature sensor of indoor unit	Inlet pipe temperature sensor of indoor unit is open or short
	0	3	-	Communication error : wired remote controller ↔ indoor unit	Failing to receive wired remote controller signal in indoor unit PCB
	0	4	-	Drain pump	Malfunction of drain pump
	0	5	-	Communication error : outdoor unit ↔ indoor unit	Failing to receive outdoor unit signal in indoor unit PCB
	0	6	-	Outlet pipe temperature sensor of indoor unit	Outlet pipe temperature sensor of indoor unit is open or short
	0	9	-	Indoor EEPROM Error	In case when the serial number marked on EEPROM of Indoor unit is 0 or FFFFFF
	1	0	-	Poor fan motor operation	Disconnecting the fan motor connector/Failure of indoor fan motor lock
	1	1	-	Communication error, Indoor unit ↔ Outdoor unit	Failing to receive signal in indoor unit
Outdoor unit related error	2	1	*	Outdoor Unit Inverter Compressor IPM Fault	Outdoor Unit Inverter Compressor Drive IPM Fault
	2	2	*	Inverter Board Input Over Current(RMS) of Outdoor Unit	Outdoor Unit Inverter Board Input Current excess (RMS)
	2	3	*	Outdoor Unit Inverter Compressor DC link Low Voltage	DC charging is not performed at Outdoor Unit after starting relay turn on.
	2	4	*	Outdoor Unit High Pressure Switch	System is turned off by Outdoor Unit high pressure switch.
	2	5	*	Outdoor Unit Input Voltage High/ Low Voltage	Outdoor Unit input voltage is over 289V or below 73V(ARUB***BTE4) Outdoor Unit input voltage is over 506V or below 414V(ARUB***DTE4)
	2	6	*	Outdoor Unit Inverter Compressor Start Failure	The First Start Failure by Outdoor Unit Inverter Compressor Abnormality
	2	9	*	Outdoor Unit Inverter Compressor Over Current	Outdoor Unit Inverter Compressor Fault or Drive Fault
	3	2	*	Outdoor Unit Inverter Compressor1 High Discharge Temperature	Outdoor Unit Inverter Compressor1 High Discharge Temperature
	3	4	*	High Pressure of Outdoor Unit	High Pressure of Outdoor Unit
	3	5	*	Low Pressure of Outdoor Unit	Low Pressure of Outdoor Unit
	3	6	*	Outdoor Unit Low Compression Ratio Limited	Outdoor Unit Low Compression Ratio Limited
	4	0	*	Outdoor Unit Inverter Compressor CT Sensor Fault	Outdoor Unit Inverter Compressor CT Sensor open or short
	4	1	*	Outdoor Unit Inverter Compressor1 Discharge Temperature Sensor Fault	Outdoor Unit Inverter Compressor Discharge Temperature Sensor open or short
	4	2	*	Outdoor Unit Low Pressure Sensor Fault	Outdoor Unit Low Pressure Sensor open or short
	4	3	*	Outdoor Unit High Pressure Sensor Fault	Outdoor Unit High Pressure Sensor open or short
	4	4	*	Outdoor Unit Air Temperature Sensor Fault	Outdoor Unit Air Temperature Sensor open or short
	4	5	*	Outdoor Unit Heat Exchanger Temperature Sensor (Front side) Fault	Outdoor Unit Heat Exchanger Temperature Sensor(Front side) open or short
4	6	*	Outdoor Unit Suction Temperature Sensor Fault	Outdoor Unit Suction Temperature Sensor open or short	

Display				Title	Cause of Error	
Outdoor unit related error	5	0	*	Omitting connection of R, S, T power of Outdoor Unit	Omitting connection of outdoor unit	
	5	1	*	Excessive capacity of indoor units	Excessive connection of indoor units compared to capacity of Outdoor Unit	
	5	2	*	Communication error : inverter PCB → Main PCB	Failing to receive inverter signal at main PCB of Outdoor Unit	
	5	3	*	Communication error : indoor unit → Main PCB of Outdoor Unit	Failing to receive indoor unit signal at main PCB of Outdoor Unit .	
	5	7	*	Communication error : Main PCB → inverter PCB	Failing to receive signal main PCB at inverter PCB of Outdoor Unit	
	6	0	*	Inverter PCB EEPROM Error of Outdoor Unit	Access Error of Inverter PCB of Outdoor Unit	
	6	2	*	Outdoor Unit Inverter Heatsink High Temperature	System is turned off by Outdoor Unit Inverter Heatsink High Temperature	
	6	5	*	Outdoor Unit Inverter Heatsink Temperature Sensor Fault	Outdoor Unit Inverter Heatsink Temperature Sensor open or short	
	6	7	*	Outdoor Unit Fan Lock	Restriction of Outdoor Unit	
	7	1	*	Converter CT Sensor Error of Outdoor Unit	Converter CT Sensor open or short of Outdoor Unit	
	7	5	*	Outdoor Unit Fan CT Sensor Error	Outdoor Unit Fan CT Sensor open or short	
	7	6	*	Outdoor Unit Fan DC Link High Voltage Error	Outdoor Unit Fan DC Link High Voltage Error	
	7	7	*	Outdoor Unit Fan Over Current Error	Outdoor Unit Fan Current is over 5A	
	7	9	*	Outdoor Unit Fan Start Failure Error	Outdoor Unit Fan First Position Sensing Failure	
	8	6	*	Outdoor Unit Main PCB EEPROM Error	Communication Fail Between Outdoor Unit Main MICOM and EEPROM or omitting EEPROM	
	8	7	*	Outdoor Unit Motor PCB EEPROM Error	Communication Fail Between Outdoor Unit Fan MICOM and EEPROM or omitting EEPROM	
	1	0	4	*	Communication Error Between Outdoor Unit and Other Outdoor Unit	Failing to receive Slave Unit signal at main PCB of Outdoor Unit
	1	0	5	*	Outdoor Unit Motor PCB Communication Error	Failing to receive fan signal at main PCB of unit.
	1	0	6	*	Outdoor Unit FAN IPM Fault Error	Instant Over Current at Outdoor Unit Fan IPM
	1	0	7	*	Outdoor Unit Fan DC Link Low Voltage Error	Outdoor Unit Fan DC Link Input Voltage is under 380V
	1	1	3	*	Outdoor Unit Liquid pipe Temperature Sensor Error	Liquid pipe temperature sensor of Outdoor Unit is open or short
	1	1	4	*	Outdoor Unit Subcooling Inlet Temperature Sensor Error	Outdoor Unit Subcooling Inlet Temperature Sensor Error
	1	1	5	*	Outdoor Unit Subcooling Outlet Temperature Sensor Error	Outdoor Unit Subcooling Outlet Temperature Sensor Error
	1	1	6	*	Outdoor Unit Oil Level Sensor Error	Oil Level Sensor of Outdoor Unit is open or short
	1	4	5	*	outdoor unit Main Board - External Board communication Error	outdoor unit Main Board - External Board communication Error
	1	5	1	*	Failure of operation mode conversion at Outdoor Unit	Failure of operation mode conversion at Outdoor Unit
	1	5	3	*	Outdoor Unit Heat Exchanger Temperature Sensor (upper part) Fault	Outdoor Unit Heat Exchanger Temperature Sensor (upper part) Fault
	1	5	4	*	Outdoor Unit Heat Exchanger Temperature Sensor (lower part) Fault	Outdoor Unit Heat Exchanger Temperature Sensor(lower part) open or short
1	8	2	*	outdoor unit External Board Main-Sub Micom communication Error	Outdoor Unit Main Board Main-Sub Micom communication failed	
1	9	3	*	Outdoor Unit Fan Heatsink High Temperature	System is turned off by Outdoor Unit Fan Heatsink High Temperature	
1	9	4	*	Outdoor Unit Fan Heatsink Temperature Sensor Fault	Outdoor Unit Fan Heatsink Temperature Sensor open or short	
HR unit related error	2	0	0	1	Searching pipe Error	Failure of automatic addressing of valves
	2	0	1	C+ #HR	HR unit1 Liquid sensor error	Liquid pipe sensor of HR unit open or short
	2	0	2	C+ #HR	HR unit1 Sub Cooling Pipe In sensor error	Sub Cooling Pipe In sensor of HR unit open or short
	2	0	3	C+ #HR	HR unit1 Sub Cooling Pipe Out sensor error	Sub Cooling Pipe Out sensor of HR unit. open or short
	2	0	4	C+ #HR	Communication error	Failing to receive HR unit signal at outdoor unit
	2	0	5	C+ #HR	Communication error between HR unit and the upgraded 485 modem.	4 series upgraded 485 communication error between HR unit and HR unit modem
	2	0	6	C+ #HR	Duplicate address error of HR unit	When the HR unit address is set duplicated at the 4 series upgraded 485 communication
	2	0	7	C+ #HR	Communication error between Master and Slave Main PCB of HR Unit	When fail to communication between Master and Slave Main PCB of HR Unit
	2	0	8	C+ #HR	Communication error of EEPROM of HR Unit	When fail to communication of EEPROM of HR Unit

# CAUTION FOR REFRIGERANT LEAK

The installer and system specialist shall secure safety against leakage according to local regulations or standards. The following standards may be applicable if local regulations are not available.

## Introduction

Though the R410A refrigerant is harmless and incombustible itself, the room to equip the air conditioner should be large to such an extent that the refrigerant gas will not exceed the concentration limit even if the refrigerant gas leaks in the room.

### Concentration limit

Concentration limit is the limit of Freon gas concentration where immediate measures can be taken without hurting human body when refrigerant leaks in the air. The Concentration limit shall be described in the unit of [kg/m<sup>3</sup> (lbs/ft<sup>3</sup>)] (Freon gas weight per unit air volume) for facilitating calculation.

**Concentration limit: 0.44 kg/m<sup>3</sup> (0.028 lbs/ft<sup>3</sup>) (R410A)**

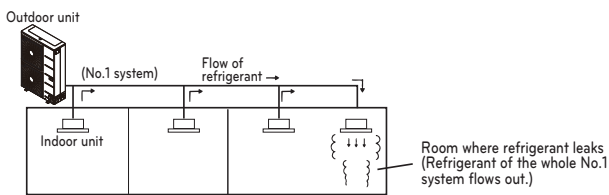

## Checking procedure of limiting concentration

Check concentration limit along following steps and take appropriate measure depending on the situation.

### Calculate amount of all the replenished refrigerant [kg (lbs)] per each refrigerant system.

Amount of replenished refrigerant per one outdoor unit system	+	Amount of additional replenished refrigerant	=	Total amount of replenished refrigerant in refrigerant facility [kg(lbs)]
Amount of replenished refrigerant at factory shipment		Amount of additionally replenished refrigerant depending on piping length or piping diameter at customer		Note : In case one refrigerant facility is divided into 2 or more refrigerant systems and each system is independent, amount of replenished refrigerant of each system shall be adopted.

### Calculate minimum room capacity

Calculate room capacity by regarding a portion as one room or the smaller room.

- Without partition

- With partition and with opening which serve as passage of air to adjoining room

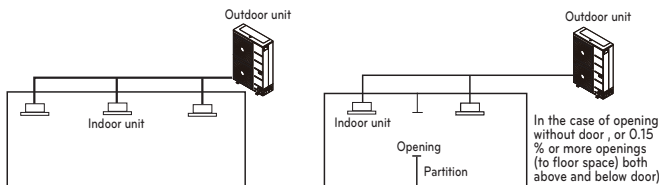

- With partition and without opening which serve as passage of air to adjoining room

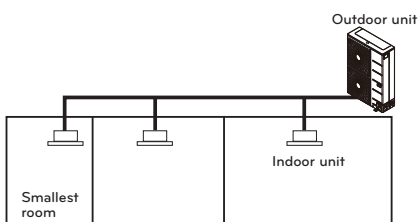

### Calculate refrigerant concentration

$$\frac{\text{Total amount of replenished refrigerant in refrigerant facility [kg(lbs)]}}{\text{Volume of smallest room where indoor unit is installed [m}^3\text{(ft}^3\text{)]}} = \text{Maximum concentration limit [kg/m}^3\text{ (lbs/ft}^3\text{)] (R410A)}$$

- In case the result of calculation exceeds the concentration limit, perform the same calculations by shifting to the second smallest, and the third smallest rooms until at last the result is below the concentration limit.

### In case the concentration exceeds the limit

When the concentration exceeds the limit, change original plan or take one of the countermeasures shown below:

- Countermeasure 1  
Provide opening for ventilation.  
Provide 0.15 % or more size of opening to floor space both above and below door, or provide opening without door.
- Countermeasure 2  
Provide gas leak alarm linked with mechanical ventilator.
- Countermeasure 3  
Reducing the outdoor refrigerant qty by dividing into smaller separate system.

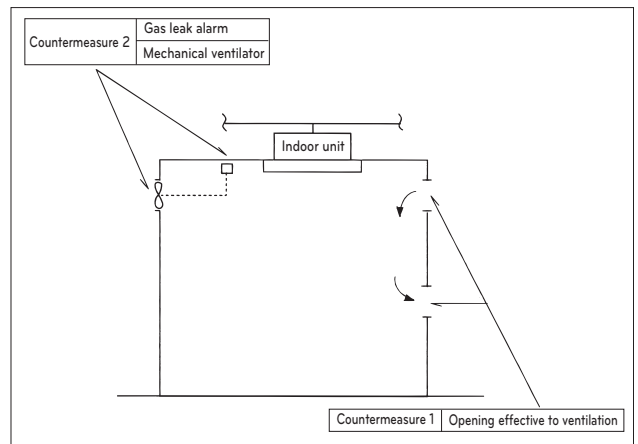

Pay a special attention to the place, such as a basement, etc. where refrigerant can stay, since refrigerant is heavier than air.

# INSTALLATION GUIDE AT THE SEASIDE

## CAUTION

- Air conditioners should not be installed in areas where corrosive gases, such as acid or alkaline gas, are produced.
- Do not install the product where it could be exposed to sea wind (salty wind) directly. It can result corrosion on the product. Corrosion, particularly on the condenser and evaporator fins, could cause product malfunction or inefficient operation.
- If outdoor unit is installed close to the seaside, it should avoid direct exposure to the sea wind. Otherwise it needs additional anticorrosion treatment on the heat exchanger.

## Selecting the location(Outdoor Unit)

If the outdoor unit is to be installed close to the seaside, direct exposure to the sea wind should be avoided. Install the outdoor unit on the opposite side of the sea wind direction.

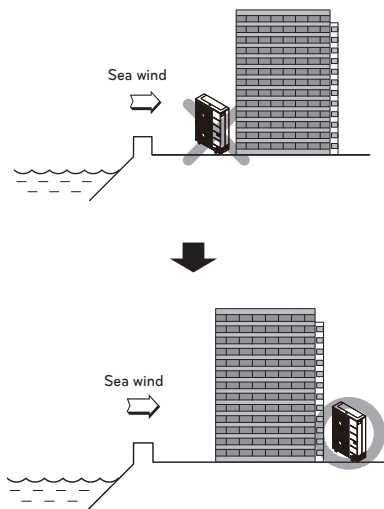

In case, to install the outdoor unit on the seaside, set up a windbreak not to be exposed to the sea wind.

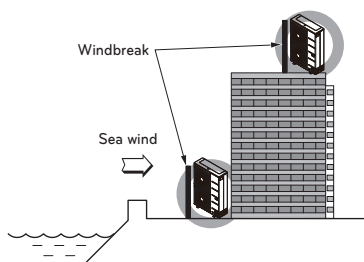

- It should be strong enough like concrete to prevent the sea wind from the sea.
- The height and width should be more than 150 % of the outdoor unit.
- It should be kept more than 70 cm (2.3 ft) of distance between outdoor unit and the windbreak for smooth air flow.

Select a well-drained place.

- Periodic (1 times per 6 months) cleaning of the dust or salt particles stuck on the heat exchanger is necessary by using clean water

## Model Designation

### Product information

- Product Name : Air conditioner
- Model Name :

Product Sales Name	Model Factory Name
ARUx***ySSz	
x = N(Heat Pump), V (Cooling only), B(Heat Recovery) M(Both Heat Pump and Heat Recovery)	
y = G(1Ø, 208/230 V, 60 Hz)	
z = Numeric; (Series Number)	
*** = Numeric; (Cooling capacity)	

- Additional information : Serial number is refer to the bar code on the product.

## Airborne Noise Emission

The A-weighted sound pressure emitted by this product is below 70 dB.

\*\* The noise level can vary depending on the site.

The figures quoted are emission level and are not necessarily safe working levels.

Whilst there is a correlation between the emission and exposure levels, this cannot be used reliably to determine whether or not further precautions are required.

Factor that influence the actual level of exposure of the workforce include the characteristics of the work room and the other sources of noise, i.e. the number of equipment and other adjacent processes and the length of time for which an operator exposed to the noise. Also, the permissible exposure level can vary from country to country.

This information, however, will enable the user of the equipment to make a better evaluation of the hazard and risk.





US	Please call the installing contractor of your product, as warranty service will be provided by them.
CANADA	Service call Number # : (888) LG Canada, (888) 542-2623 Numéro pour les appels de service : LG Canada, 1-888-542-2623