



LG UltraGear™

Gaming Monitor

(LED*)

* LED

LG

LCD

38GN950/38GN950P
38GN95B

.....3

.....4

.....4

.....5

.....5

..7

- HDMI

- HDMI

USB

DisplayPort
AV

.....15

.....15

.....16

.....17

.....18

.....18

.....20

.....32

.....35

.....39

- HDMI ().....40

www.lg.com.



Термините HDMI и Интерфейс за мултимедия с висока разделителна способност HDMI (HDMI - High-Definition Multimedia Interface), както и логото HDMI са запазени марки на HDMI Licensing Administrator, Inc. в Съединените щати и други държави.



The SuperSpeed USB Trident logo is a registered trademark of USB Implementers Forum, Inc.



MaxxAudio and additional MAXX trademarks are trademarks and/or registered trademarks of Waves Audio Ltd.

com.

GPL, LGPL, MPL

<http://opensource.lge.com>



LG Electronics
ROM

CD-

e

LG,

),
opensource@lge.com.

(,)
(. ())



-
-
-
-

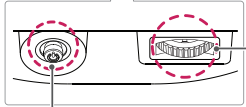

/ LED



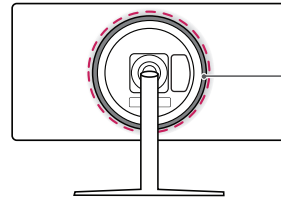



-
-





LGE

(www.lg.com).

OnScreen Control	
LG UltraGear™ Control Center	

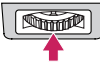
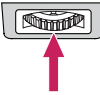
			
			10
			/
			(SDR) /

		
		
		



-
-

(Settings () > General () > Lighting Option () > Keep Lighting Status ())

- LED

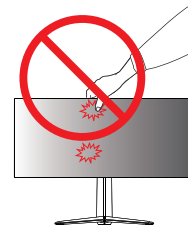
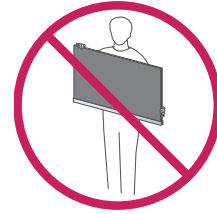
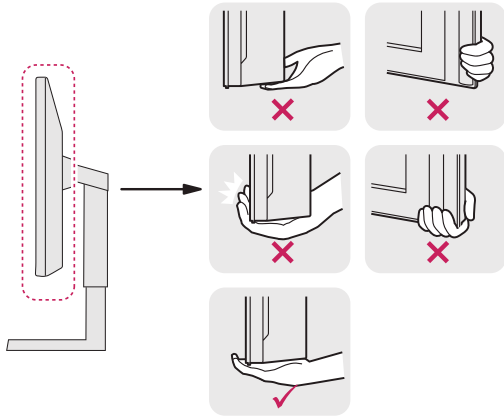

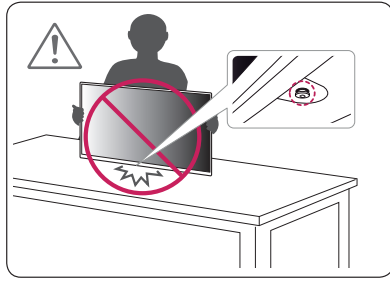

1

100

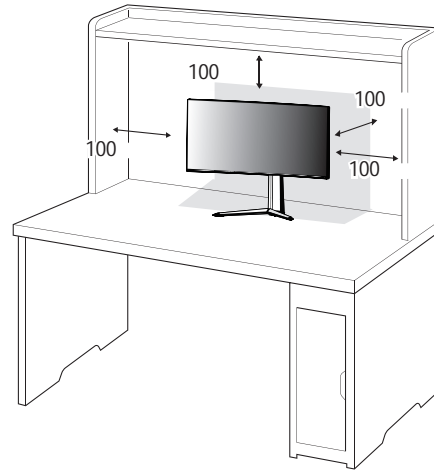

1
2

.110,0

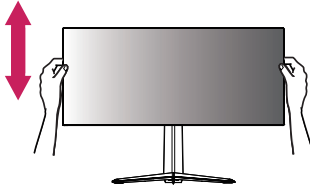

1
2

15°



-5°

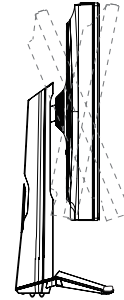

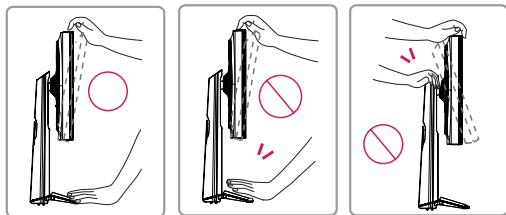

(3°).

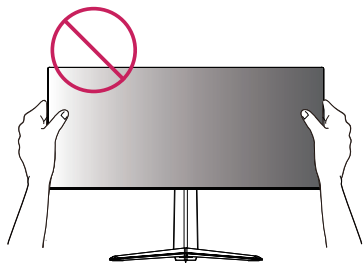
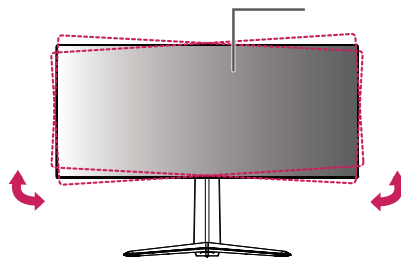

Kensington

Kensington

Kensington

<http://www.kensington.com>.

Kensington.

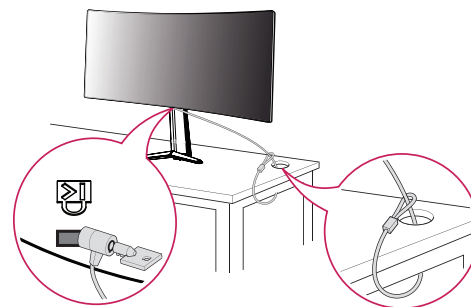
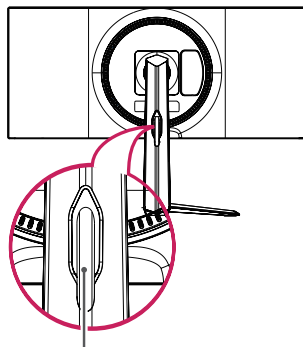
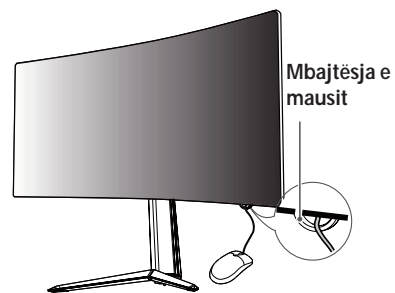

Kensington

1

(),

2

3

4



100

100

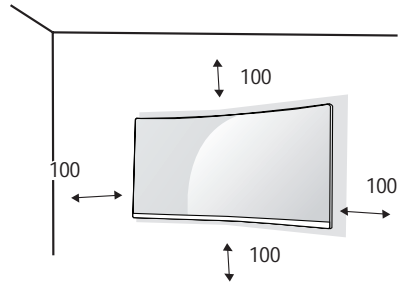

()



VESA.

-
-
-
-
-

1

2

VESA,
. LG Electronics



-
-
-
-

LG

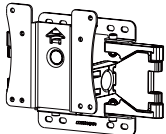
()	100 x 100
	M4 x L10
	4
()	LSW 149 

VESA.

8

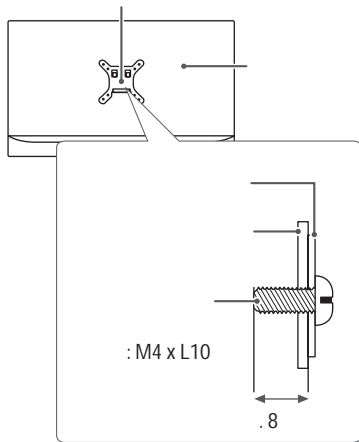

DisplayPort

AV

HDMI

HDMI

AV



DP(DisplayPort)

DisplayPort



DVI

HDMI / DP (DisplayPort)

HDMI

HDMI.

HDMI

HDMI

HDMI®/™

HDMI®/™

Ethernet

USB

USB

USB 3.0,

USB

USB 3.0

A-B

USB IN,



-
-



-

-

-

USB

Windows

USB

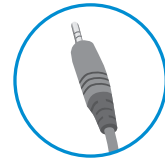

-

USB

USB

-

USB

-

USB

.(

USB

)

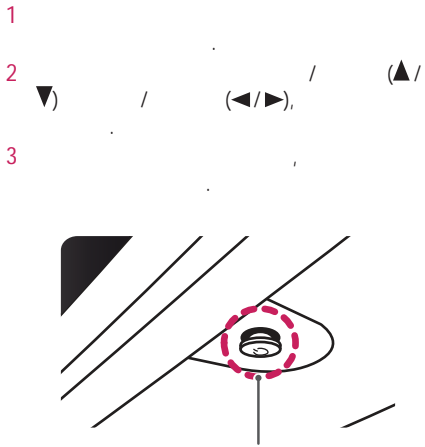

		()
	◀	
	▶	Input ().
	▲	
		Settings ().
	▼	
		Game Mode ().

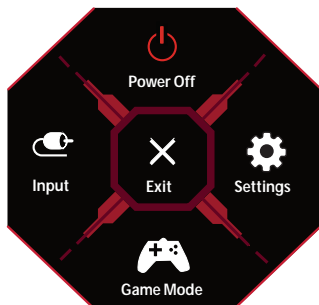

Input ()	
Power Off ()	
Settings ()	
Game Mode ()	
Exit ()	

- 1
- 2
- 3
- 4

Settings ()



Game Mode ()

Game Adjust ()

Picture Adjust ()

Input ()

General ()

Game Mode () SDR(-HDR)

Settings () > Game Mode ()		
Game Mode ()	Gamer 1 (1)	Gamer 1 (1) Gamer 2 (2)
	Gamer 2 (2)	
	FPS	FPS FPS
	RTS	RTS
	Vivid	
	Reader ()	
	HDR Effect	
	sRGB	RGB

Game Mode () HDR

Settings () > HDR Game Mode ()	
HDR Game Mode (HDR)	Gamer 1 (1)
	Gamer 2 (2)
	FPS
	RTS
	Vivid
 <ul style="list-style-type: none"> • HDR HDR On / Off (/) Windows. Windows 10 / macOS. • HDR. • on / off (/) HDR. 	

Settings () > Game Adjust ()			
Game Adjust ()	Overclock ()	On (.)	Overclock () -
		Off (.)	Overclock () .
		 <ul style="list-style-type: none"> • GPU. • Overclock () . • DisplayPort. • / Overclock () • 	





Game Adjust ()	Adaptive-Sync		
		<ul style="list-style-type: none"> • HDMI (FreeSync / FreeSync Premium / FreeSync Premium Pro) • : DisplayPort,HDMI. • • • 	AMD FreeSync Tier , Adaptive-Sync. NVIDIA,G-SYNC, AMD FreeSync. NVIDIA : (www.nvidia.com) AMD :
		(www.amd.com).	
	On (.)	Adaptive-Sync.	
	Off (.)	Adaptive-Sync.	
	Black Stabilizer ()		



Game Adjust ()	Response Time ()	Fast (). Faster (-).	
		Faster (-)	
		Faster (-)	Faster (-).
		Fast ()	Fast ().
	Normal ()	Normal ().	
	Off ()		
	Cross Hair ()	Cross Hair () (FPS). • Cross Hair ()	
	Game Reset ()	No ()	
	Yes ()		



Settings () > Picture Adjust ()				
Picture Adjust ()	Brightness ()			
	Contrast ()			
	Sharpness ()			
	Gamma ()	Mode 1 (1), Mode 2 (2), Mode 3 (3)		
		Mode 4 (4)	Mode 4 (4).	
	Color Temp ()	Custom ()		
		Warm ()		
		Medium ()		
		Cool ()		
		Manual		
R/G/B	червен, зелен и син.			
Six Color ()	Green, Blue, Cyan, Magenta, Yellow) (Red,			
	Hue ()			
	Saturation ()			

Picture Adjust ()	Black Level ()	• Offset (): (HDMI).	
		High()	
		Low ()	
	DFC	On (.)	
		Off (.)	DFC.
	Picture Reset ()	No ()	
		Yes ()	

Settings () > Input ()			
Input ()	Input ()		
	Ratio ()	Full Wide ()	
		Original ()	
		Just Scan ()	
		 <ul style="list-style-type: none"> • Just Scan () Full Wide (), Original () (3840 x 1600) • Just Scan () Adaptive-Sync (Adaptive-Sync) () () <p>Settings () Game Adjust () Adaptive-Sync (Adaptive-Sync), Adaptive-Sync On (Adaptive-Sync) Off ()</p>	
	Auto Input Switch	On (),	
		On ()	Auto Input Switch.
		Off ()	Auto Input Switch.

Settings () >				
General ()	Waves MaxxAudio®	Over-the-ear		
		On-ear		
		Ear-Buds		
		Off ()	Waves Maxx Audio.	
		Language ()		
	SMART ENERGY SAVING	High ()		SMART ENERGY SAVING.
		Low ()		SMART ENERGY SAVING.
		Off ()		SMART ENERGY SAVING.
	Lighting Option ()	Keep Lighting Status ()		
		Turn Off Lighting ()		'Keep Lighting Status ()':

General ()	Power LED (LED)	LED		
		On (.)	LED • (.) : • •	
		Off (.)	LED	
	Automatic Standby	. (Off (.), 4H (4 .), 6H (6 .), 8H (8 .))		
	HDMI Compatibility Mode (HDMI)	HDMI Compatibility Mode (HDMI) HDMI 2.0.		
		On (.)	HDMI Compatibility Mode (HDMI) .	
		Off (.)	HDMI Compatibility Mode (HDMI) .	
		 <p>HDMI Compatibility Mode (HDMI) , HDMI , 3840 x 1600 @ 100/120/144Hz HDMI 2.0, HDMI 2.0</p>		
				
	DisplayPort Version (DisplayPort)	Please set the DisplayPort version to match the version of the connected external device(1.4,1.2 and 1.1) . If you want to use the HDR, select the DP version to 1.4 .		
	Local Dimming ()			
		Off (.)	Local Dimming (.) .	
		On (.)	Local Dimming (.) .	
Auto (.)				
	Off (.)			

General ()	Variable Backlight ()			
		Faster (-)		
		Fast ()		
		Normal ()		
		Off (.)		
		 <ul style="list-style-type: none"> • HDR 		
	Buzzer ()		Buzzer (), On (.)	
		On (.)	Buzzer ()	
		Off (.)	Buzzer ()	
	OSD Lock ()			
		On (.)	OSD Lock ()	
		Off (.)	OSD Lock ()	
		 <ul style="list-style-type: none"> • Brightness (), Contrast () Picture Adjust () input (), OSD Lock () Information () General () 		
	Information ()		Total Power On Time (), Resolution	
	Reset to Initial Settings	No ()		
Yes ()				

?	•
LED ?	•
? LED	• (Settings () > Input ()).
LED ?	•
The screen is not currently set to the recommended resolution. If you have no video or the screen flickers, see the troubleshooting guide in the product owner's manual. ()?	• () " "
No Signal ()?	•
?	• http://www.lg.com • Plug and Play.

()? Menu	• OSD Lock (Settings () > General () Off ()).

?	

./	
?	HDMI 1080i 60/50 Hz (interlaced), 1080p



- : Hz.
- : 1 kHz.
- > > Windows. ()
- ()
-
- 3840 x 1600.

(16)?	<ul style="list-style-type: none"> • > > > 24 () . Windows
?	<ul style="list-style-type: none"> • , .
?	<ul style="list-style-type: none"> • ,). LCD (, , ,

(DisplayPort) HDMI DP ?	<ul style="list-style-type: none"> • , • , • , Microsoft Windows <p>(> > >)</p>

38GN950 38GN950P

LCD			HDMI	8- /10- .
			DP (DisplayPort)	8- /10- .
	HDMI	3840 x 1600 @ 75 Hz		
		3840 x 1600 @ 75 Hz		
	DP	3840 x 1600 @ 144 Hz		
		3840 x 1600 @ 160 Hz (Overclock (): On (.))		
		3840 x 1600 @ 144 Hz		
			19V --- 7,0 A	
	()		: 95 W ()* (): 0,5 W** : 0,3 W	
AC/DC	A16-140P1A, CHICONY POWER TECHNOLOGY Co., Ltd. ADS-150KL-19N-3 190140E, SHENZHEN HONOR ELECTRONIC : 19V --- 7,37 A			
			0 °C 40 °C	
			80 %	
			-20 °C 60 °C	
			85 %	
	(x x)			
			896,4 x 588,4 x 312,2 ()	
			896,4 x 394,4 x 111,3 ()	

38GN95B

LCD			HDMI	8- /10-
			DP (DisplayPort)	8- /10-
	HDMI		3840 x 1600 @ 75 Hz	
			3840 x 1600 @ 75 Hz	
	DP		3840 x 1600 @ 144 Hz	
			3840 x 1600 @ 160 Hz (Overclock (): On ())	
		3840 x 1600 @ 144 Hz		
			19 V --- 7,0 A	
	()		: 46 W . (ENERGY STAR®) * (): 0,5 W ** : 0,3 W	
AC/DC	A16-140P1A, CHICONY POWER TECHNOLOGY Co., Ltd. ADS-150KL-19N-3 190140E, SHENZHEN HONOR ELECTRONIC : 19 V --- 7,37 A			
			0 °C 40 °C	
			80 %	
			-20 °C 60 °C	
			85 %	
	(x x)			
			896,4 x 588,4 x 312,2 ()	
			896,4 x 394,4 x 111,3 ()	

()	9,2
	7,0

*

*

(5).

ENERGY STAR®.

(, HDMI/ DisplayPort PC)

	(kHz)	(Hz)	(H/V)	
640 x 480	31,469	59,94	-/-	
800 x 600	37,879	60,317	+/+	
1024 x 768	48,363	60	-/-	
1920 x 1080	67,50	60	+/+	
2560 x 1440	183	120	+/-	HDMI FreeSync Premium Pro
3840 x 1600	48,69	30	+/-	HDMI
3840 x 1600	98,75	59,99	+/-	
3840 x 1600	124,31	74,98	+/-	
3840 x 1600	203,25	119,98	+/-	DP 1.4
3840 x 1600	246,8	143,99	+/-	DP 1.4
3840 x 1600	267,2	160	+/-	DP O/C

HDMI ()

	(kHz)	(Hz)
480p	31,5	60
720p	45	60
1080p	67,5	60
2160p	135	60



Модел _____

Сериен номер _____

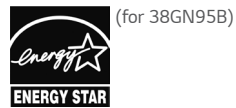

This Product qualifies for ENERGY STAR®

Changing the factory default configuration and settings or enabling certain optional features and functionalities may increase energy consumption beyond the limits required for ENERGY STAR® certification.

Refer to ENERGYSTAR.gov for more information on the ENERGY STAR® program.