



INSTALLATION MANUAL

AIR CONDITIONER

Please read this installation manual completely before installing the product.

Installation work must be performed in accordance with the national wiring standards by authorized personnel only.

Please retain this installation manual for future reference after reading it thoroughly.

Vertical Air Handling Unit

ENGLISH

FRANÇAIS

ESPAÑOL

IMPORTANT!

PLEASE READ THIS INSTRUCTION SHEET COMPLETELY BEFORE INSTALLING THE PRODUCT.

This air conditioning system meets strict safety and operating standards. As the installer or service person, it is an important part of your job to install or service the system so it operates safely and efficiently.

WARNING

- Installation or repairs made by unqualified persons can result in hazards to you and others. Installation of all field wiring and components **MUST** conform with local building codes or, in the absence of local codes, with the National Electrical Code 70 and the National Building Construction and Safety Code or Canadian Electrical code and National Building Code of Canada.
- The information contained in the manual is intended for use by a qualified service technician familiar with safety procedures and equipped with the proper tools and test instruments.
- Failure to carefully read and follow all instructions in this manual can result in equipment malfunction, property damage, personal injury and/or death.

CAUTION

- Improper installation, adjustment, alteration, service or maintenance can void the warranty. The weight of the condensing unit requires caution and proper handling procedures when lifting or moving to avoid personal injury. Use care to avoid contact with sharp or pointed edges.

Safety Precautions

- Always wear safety eye wear and work gloves when installing equipment.
- Never assume electrical power is disconnected. Check with meter and equipment.
- Keep hands out of fan areas when power is connected to equipment.

NOTE TO INSTALLING DEALER

- The Owners Instructions and Warranty are to be given to the owner or prominently displayed near the indoor Furnace/Air Handler Unit.

Special warnings

• When wiring

- **Electrical shock can cause severe personal injury or death. Only a qualified, experienced electrician should attempt to wire this system.**
 - a) Do not supply power to the unit until all wiring and tubing are completed or reconnected and checked.
 - b) Highly dangerous electrical voltages are used in this system. Carefully refer to the wiring diagram and these instructions when wiring. Improper connections and inadequate grounding can cause accidental injury or death.
 - c) Ground the unit following local electrical codes.
 - d) Connect all wiring tightly. Loose wiring may cause overheating at connection points and a possible fire hazard.
 - e) The choice of materials and installations must comply with the applicable local/national or international standards.
 - f) Do NOT connect a power supply to terminal block of AC 24 V (external terminal). If the power supply is connected to the external terminal block, it may cause the damage to the indoor unit.

• When transporting

- Be careful when picking up and moving the indoor and outdoor units. Get a partner to help, and bend your knees when lifting to reduce strain on your back. Sharp edges or thin aluminum fins on the air conditioner can cut your finger.

• When installing...

- **... in a wall:** Make sure the wall is strong enough to hold the unit's weight. It may be necessary to construct a strong wood or metal frame to provide added support.
- **... in a room:** Properly insulate any tubing run inside a room to prevent "sweating" that can cause dripping and water damage to wall and floors.
- **... in moist or uneven locations:** Use a raised concrete pad or concrete blocks provide a solid, level foundation for the outdoor unit. This prevents water damage and abnormal vibration.
- **... in an area with high winds:** Securely anchor the outdoor unit down with bolts and a metal frame. Provide a suitable air baffle.
- **... in a snowy area (for Heat Pump Model):** Install the outdoor unit on a raised platform that is higher than drifting snow. Provide snow vents.

• When connecting refrigerant tubing

- Keep all tubing runs as short as possible.
- Use the flare method for connecting tubing.
- Check carefully for leaks before starting the test run.

• When servicing

- Turn the power OFF at the main power box (mains) before opening the unit to check or repair electrical parts and wiring.
- Keep your fingers and clothing away from any moving parts.
- Clean up the site after you finish, remembering to check that no metal scraps or bits of wiring have been left inside the unit being serviced.

TABLE OF CONTENTS

2 IMPORTANT!

- 2 Please read this instruction sheet completely before installing the product.

6 FEATURES

- 7 Duct Connection Dimensions

8 TIPS FOR SAVING ENERGY

9 SAFETY INSTRUCTIONS

- 10 Installation
- 12 Operation
- 12 Service & Installation

18 SAFETY PRECAUTIONS

- 18 WARNING (Installation)
- 19 WARNING (Operation)
- 21 CAUTION (Installation)
- 21 CAUTION (Operation)
- 22 CAUTION (Service)

23 MINIMUM FLOOR AREA

- 24 Minimum floor area for Single-Split System
(UL 60335-2-40:2019 Edition 3)
- 29 Minimum total conditioned room area
(UL 60335-2-40:2019 Edition 3)
- 31 Minimum floor area for Multi-Split System
(UL 60335-2-40:2019 Edition 3)
- 36 Minimum floor area for ETRS unit
(UL 60335-2-40:2022 Edition 4)
- 41 Minimum total conditioned room area
(UL 60335-2-40:2022 Edition 4)
- 45 Altitude adjustment

46 R32 LEAK DETECTION SYSTEM

- 47 Troubleshooting

TABLE OF CONTENTS

49 INSTALLATION

- 49 Selection of the best location
- 51 Upflow Installation
- 52 Duct work
- 53 Downflow Installation
- 54 Horizontal Installation (Left & Right)
- 56 Preparation of Piping
- 58 Connection of piping - Indoor, Outdoor, BD Unit
- 60 Connecting Pipes to the Indoor Unit
- 63 Plumbing materials and storage methods
- 65 Insulation
- 67 Condensate Drain
- 69 Wiring Connection
- 73 Electric Heater
- 74 Remote controller installation
- 76 Wired remote controller installation
- 77 3rd Party Thermostat
- 78 Dip Switch Setting
- 79 Airborne Noise Emission

80 PRODUCT DATA

- 80 External Static Pressure & Air Flow
- 81 External Static Pressure & Air Flow (Manual setting)
- 83 Electric Heater Static pressure drop factors
- 84 Air Filter (Field supply) Static pressure drop factors

FEATURES

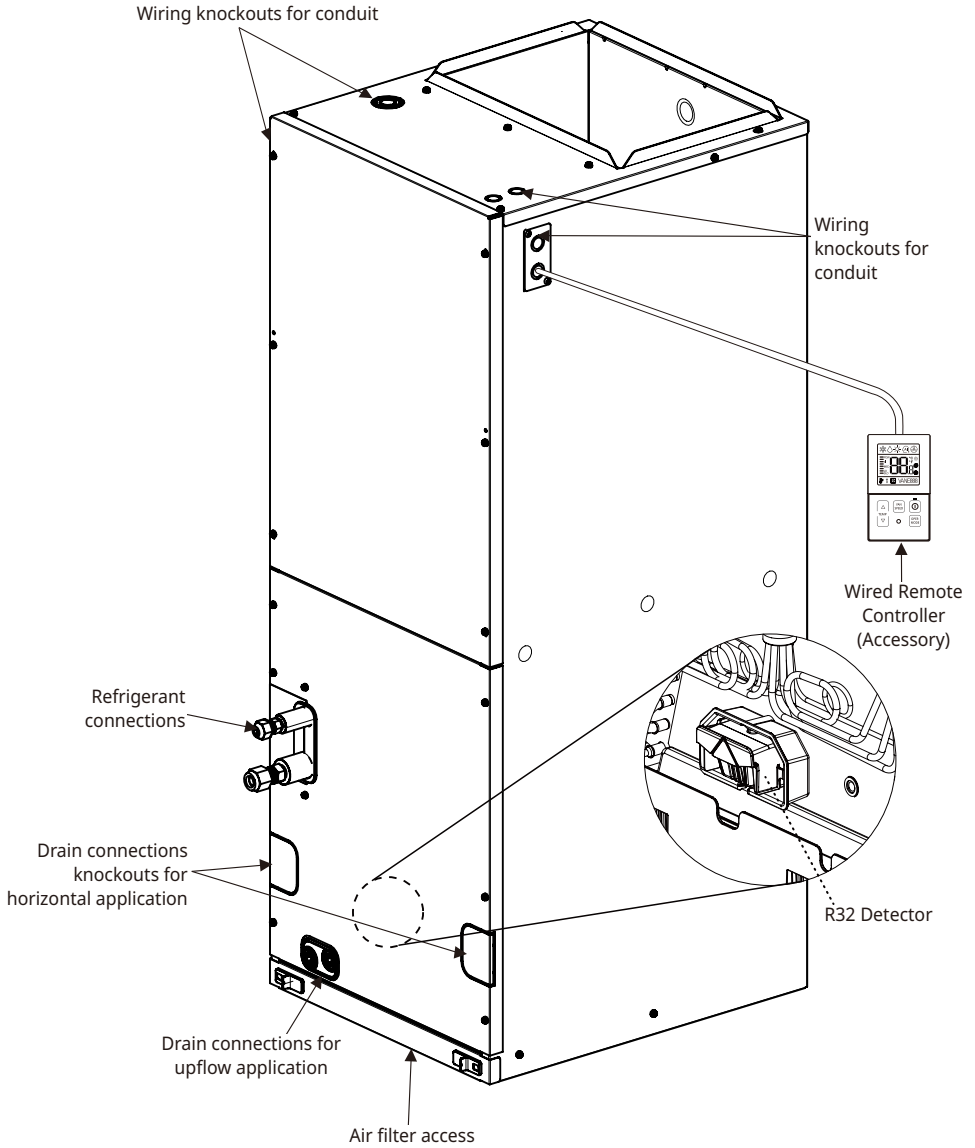

Duct Connection Dimensions

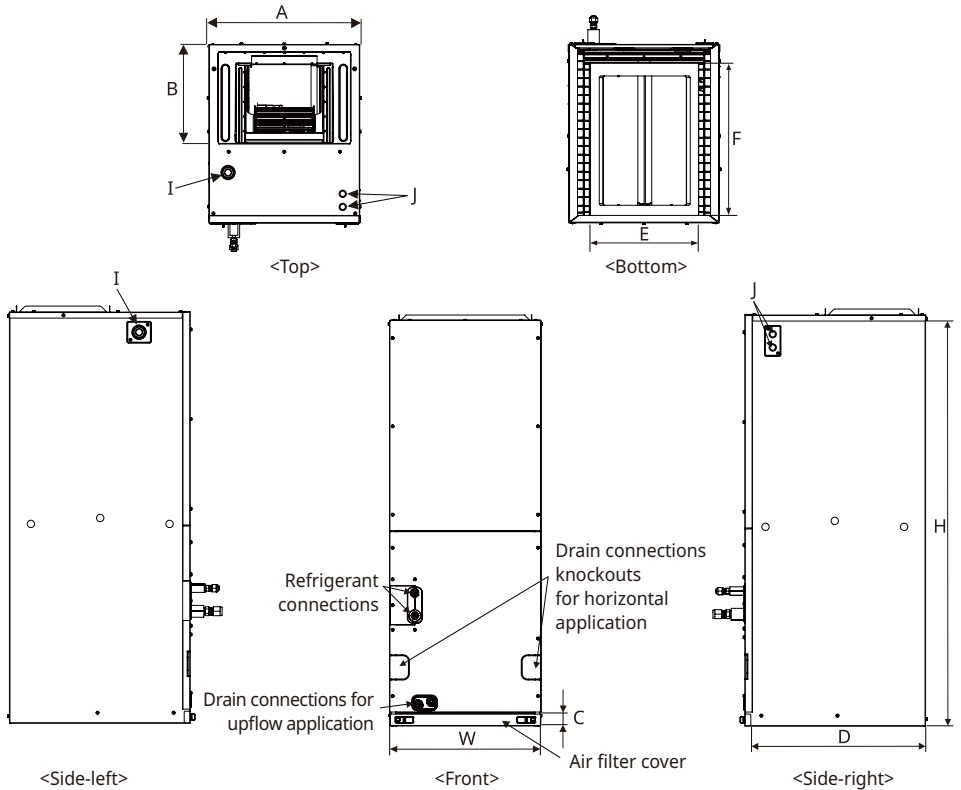

(Unit: inch (mm))

ODU	Capacity (kBtu/h (RT))	Dimensions								Wiring Knock out		Refrigerant Connections Pipe size	
		H	W	D	A	B	C	E	F	I	J	Liquid	Gas
		Height	Width	Depth						Heater Power	Main power, Communication		
Single Zone	12(1.0)	48 - 21/32 (1 236)	18 (457)	21 - 3/8 (543)	16 (405.8)	11 - 1/16 (281.3)	1 - 11/16 (42.5)	13 - 3/32 (332.6)	18 - 5/16 (465)	1 - 11/16 (43)	7/8 (22)	3/8 (9.52)	3/8 (9.52)
	18(1.5)												
	24(2.0)												
	30(2.5)	55 - 3/16 (1 401)	21 (533)	21 - 3/8 (543)	19 (482)	11 - 1/16 (281.3)	1 - 11/16 (42.5)	16 - 3/32 (408.8)	18 - 5/16 (465)	1 - 11/16 (43)	7/8 (22)	3/8 (9.52)	5/8 (15.88)
	36(3.0)												
	42(3.5)												
48(4.0)	55 - 3/16 (1 401)	25 (635)	21 - 3/8 (543)	23 (583.8)	11 - 1/16 (281.3)	1 - 11/16 (42.5)	20 - 3/32 (510.6)	18 - 5/16 (465)	1 - 11/16 (43)	7/8 (22)	3/8 (9.52)	3/4 (19.05)	
60(5.0)													
Multi Zone	12(1.0)	48 - 21/32 (1 236)	18 (457)	21 - 3/8 (543)	16 (405.8)	11 - 1/16 (281.3)	1 - 11/16 (42.5)	13 - 3/32 (332.6)	18 - 5/16 (465)	1 - 11/16 (43)	7/8 (22)	1/4 (6.35)	3/8 (9.52)
	18(1.5)												
	24(2.0)												
	30(2.5)	55 - 3/16 (1 401)	21 (533)	21 - 3/8 (543)	19 (482)	11 - 1/16 (281.3)	1 - 11/16 (42.5)	16 - 3/32 (408.8)	18 - 5/16 (465)	1 - 11/16 (43)	7/8 (22)	3/8 (9.52)	5/8 (15.88)
	36(3.0)												

TIPS FOR SAVING ENERGY

Here are some tips that will help you minimize the power consumption when you use the air conditioner. You can use your air conditioner more efficiently by referring to the instructions below:

- Do not cool excessively indoors. This may be harmful for your health and may consume more electricity.
- Block sunlight with blinds or curtains while you are operating the air conditioner.
- Keep doors or windows closed tightly while you are operating the air conditioner.
- Adjust the direction of the air flow vertically or horizontally to circulate indoor air.
- Speed up the fan to cool or warm indoor air quickly, in a short period of time.
- Open windows regularly for ventilation as the indoor air quality may deteriorate if the air conditioner is used for many hours.
- Clean the air filter once every 2 weeks. Dust and impurities collected in the air filter may block the air flow or weaken the cooling / dehumidifying functions.

For your records

Staple your receipt to this page in case you need it to prove the date of purchase or for warranty purposes. Write the model number and the serial number here:

Model number : _____





Serial number : _____

You can find them on a label on the side of each unit.

Dealer's name : _____

Date of purchase : _____

SAFETY INSTRUCTIONS

	Read the precautions in this manual carefully before operating the unit.
	This symbol indicates that the Operation Manual should be read carefully.
	This appliance is filled with flammable refrigerant.
	This symbol indicates that a service personnel should be handling this equipment with reference to the Installation Manual.

The following safety guidelines are intended to prevent unforeseen risks or damage from unsafe or incorrect operation of the appliance.

The guidelines are separated into 'WARNING' and 'CAUTION' as described below.



This symbol is displayed to indicate matters and operations that can cause risk. Read the part with this symbol carefully and follow the instructions in order to avoid risk.



WARNING

This indicates that the failure to follow the instructions can cause serious injury or death.



CAUTION

This indicates that the failure to follow the instructions can cause the minor injury or damage to the product.

WARNING

- Installation or repairs made by unqualified persons can result in hazards to you and others.
- Installation of all field wiring and components **MUST** conform with local building codes or, in the absence of local codes, with the National Electrical Code 70 and the National Building Construction and Safety Code or Canadian Electrical code and National Building Code of Canada.
- The information contained in the manual is intended for use by a qualified service technician familiar with safety procedures and equipped with the proper tools and test instruments.
- Failure to carefully read and follow all instructions in this manual can result in equipment malfunction, property damage, personal injury and/or death.

Installation

- Always perform grounding.
 - Otherwise, it may cause electrical shock.
- For installation of the product, always contact the service center or a professional installation agency.
 - Otherwise, it may cause a fire, electrical shock, explosion or injury.
- Securely attach the electrical part cover to the indoor unit and the service panel to the outdoor unit.
 - If the electrical part cover of the indoor unit and the service panel of the outdoor unit are not attached securely, it could result in a fire or electric shock due to dust, water, etc.
- Always install an air leakage breaker and a dedicated switching board.
 - No installation may cause a fire and electrical shock.
- Do not keep or use flammable gases or combustibles near the air conditioner.
 - Otherwise, it may cause a fire or the failure of product.
- Ensure that an installation frame of the outdoor unit is not damaged due to use for a long time.
 - It may cause injury or an accident.
- Do not disassemble or repair the product randomly.
 - It will cause a fire or electrical shock.
- Do not install the product at a place that there is concern of falling down.
 - Otherwise, it may result in personal injury.
- Use caution when unpacking and installing.
 - Sharp edges may cause injury.
- Use a vacuum pump or Inert (nitrogen) gas when doing leakage test or air purge. Do not compress air or Oxygen and Do not use Flammable gases. Otherwise, it may cause fire or explosion. There is the risk of death, injury, fire or explosion.
- Consult your local dealer regarding what to do in case of refrigerant leakage. When the air conditioner is to be installed in a small room, it is necessary to take proper measures so that the amount of any leaked refrigerant does not exceed the concentration limit in the event of a leakage. Otherwise, this may lead to an accident due to oxygen depletion.
- Carry out the specified installation work after taking into account earthquakes. Failure to do so during installation work may result in the unit falling and causing accidents.
- Make sure that a separate power supply circuit is provided for this unit and that all electrical work is carried out by qualified personnel according to local laws and regulations and this installation manual. An insufficient power supply capacity or improper electrical construction may lead to electric shocks or fire.
- Be sure to switch off the unit before touching any electrical parts.
- Make sure that all wiring is secured, the specified wires are used, and that there is no strain on the terminal connections or wires.
- If refrigerant gas leaks during installation, ventilate the area immediately. Toxic gas may be produced if the refrigerant gas comes into contact with fire.

- Make sure to be materials in a compartment handling air for circulation through a duct supplying only one room.
- Do not store or use flammable gas or combustibles near the unit.
 - There is risk of fire, explosion, and physical injury or death.
- Do not use means to accelerate the defrosting process or to clean, other than those recommended by the manufacturer.
- The appliance shall be stored in a room without continuously operating ignition sources (For example: open flames, an operating gas appliance or an operating electric heater.)
- Do not pierce or burn.
- Be aware that refrigerants may not contain an odour.
- The manufacturer may provide other suitable examples or may provide additional information about the refrigerant odour.
- Pipe-work including piping material, pipe routing, and installation shall include protection from physical damage in operation and service, and be in compliance with national and local codes and standards, such as ASHRAE 15, IAPMO Uniform Mechanical Code, ICC International Mechanical Code, or CSA B52. All field joints shall be accessible for inspection prior to being covered or enclosed.
- An unventilated area where the appliance using flammable refrigerants is installed shall be so constructed that should any refrigerant leak, it will not stagnate so as to create a fire or explosion hazard.
- Field-made refrigerant joints indoors shall be tightness tested. The test method shall have a sensitivity of 5 grams per year of refrigerant or better under a pressure of at least 0,25 times the maximum allowable pressure. No leak shall be detected.
- If appliances connected via an air duct system to one or more rooms with A2L REFRIGERANTS are installed in a room with an area less than Amin as determined in standard, that room shall be without continuously operating open flames (e.g. an operating gas appliance) or other POTENTIAL IGNITION SOURCES (for e.g., an operating electric heater, hot surfaces). A flameproducing device may be installed in the same space if the device is provided with an effective flame arrest.
- After completion of field piping for split systems, the field pipework shall be pressure tested with an inert gas and then vacuum tested prior to refrigerant charging, according to the following requirements:
 - The minimum test pressure for the low side of the system shall be the low side design pressure and the minimum test pressure for the high side of the system shall be the high side design pressure, unless the high side of the system, cannot be isolated from the low side of the system in which case the entire system shall be pressure tested to the low side design pressure.
 - The test pressure after removal of pressure source shall be maintained for at least 1 h with no decrease of pressure indicated by the test gauge, with test gauge resolution not exceeding 5% of the test pressure.
- During the evacuation test, after achieving a vacuum level specified in the manual or less, the refrigeration system shall be isolated from the vacuum pump and the pressure shall not rise above 1500 microns within 10 min. The vacuum pressure level shall be specified in the manual, and shall be the lessor of 500 microns or the value required for compliance with national and local codes and standards, which may vary between residential, commercial, and industrial buildings.
- Do not install indoor units in laundry rooms.

Operation

- Unplug the unit if strange sounds, smell, or smoke comes from it.
 - Otherwise, it may cause electrical shock or a fire.
- Keep the flames away.
 - Otherwise, it may cause a fire.
- Take the power plug out if necessary, holding the head of the plug and do not touch it with wet hands.
 - Otherwise, it may cause a fire or electrical shock.
- Do not open the suction inlet of the indoor/outdoor unit during operation.
 - Otherwise, it may electrical shock and failure.
- Do not allow water to run into electrical parts.
 - Otherwise, it may cause the failure of machine or electrical shock.
- Never touch the metal parts of the unit when removing the filter.
 - They are sharp and may cause injury.
- Do not step on the indoor/outdoor unit and do not put anything on it.
 - It may cause an injury through dropping of the unit or falling down.
- When the product is submerged into water, always contact the service center.
 - Otherwise, it may cause a fire or electrical shock.
- Take care so that children may not step on the outdoor unit.
 - Otherwise, children may be seriously injured due to falling down.
- The appliance shall be stored so as to prevent mechanical damage from occurring.
- This appliance is not intended for use by persons (including children) with reduced physical, sensory or mental capabilities or lack of experience and knowledge, unless they have been given supervision or instruction concerning use of the appliance by a person responsible for their safety. Children should be supervised to ensure that they do not play with the appliance.
- LEAK DETECTION SYSTEM installed. Unit must be powered except for service. This unit is equipped with a refrigerant leak detector for safety. To be effective, the unit must be electrically powered at all times after installation, other than when servicing. (LEAK DETECTION SYSTEM can be installed optionally for the safety purpose.)

Service & Installation

Checks to the area

Prior to beginning work on systems containing flammable refrigerants, safety checks are necessary to ensure that the risk of ignition is minimised. For repair to the refrigerating system, the following precautions shall be complied with prior to conducting work on the system.

Work procedure

Work shall be undertaken under a controlled procedure so as to minimise the risk of a flammable gas or vapour being present while the work is being performed.

General work area

All maintenance staff and others working in the local area shall be instructed on the nature of work being carried out. Work in confined spaces shall be avoided.

Checking for presence of refrigerant

The area shall be checked with an appropriate refrigerant detector prior to and during work, to ensure the technician is aware of potentially flammable atmospheres. Ensure that the leak detection equipment being used is suitable for use with flammable refrigerants, i.e. non-sparking, adequately sealed or intrinsically safe.

Presence of fire extinguisher

If any hot work is to be conducted on the refrigerating equipment or any associated parts, appropriate fire extinguishing equipment shall be available to hand. Have a dry powder or CO2 fire extinguisher adjacent to the charging area.

No ignition sources

No person carrying out work in relation to a refrigerating system which involves exposing any pipe work shall use any sources of ignition in such a manner that it may lead to the risk of fire or explosion.

All possible ignition sources, including cigarette smoking, should be kept sufficiently far away from the site of installation, repairing, removing and disposal, during which refrigerant can possibly be released to the surrounding space. Prior to work taking place, the area around the equipment is to be surveyed to make sure that there are no flammable hazards or ignition risks. "No Smoking" signs shall be displayed.

Ventilated area

Ensure that the area is in the open or that it is adequately ventilated before breaking into the system or conducting any hot work. A degree of ventilation shall continue during the period that the work is carried out. The ventilation should safely disperse any released refrigerant and preferably expel it externally into the atmosphere.

Checks to the refrigerating equipment

Where electrical components are being changed, they shall be fit for the purpose and to the correct specification.

At all times the manufacturer's maintenance and service guidelines shall be followed. If in doubt consult the manufacturer's technical department for assistance.

The following checks shall be applied to installations using flammable refrigerants:

- The actual refrigerant charge is in accordance with the room size within which the refrigerant containing parts are installed
- The ventilation machinery and outlets are operating adequately and are not obstructed
- If an indirect refrigerating circuit is being used, the secondary circuit shall be checked for the presence of refrigerant
- Marking to the equipment continues to be visible and legible. Markings and signs that are illegible shall be corrected
- Refrigerating pipe or components are installed in a position where they are unlikely to be exposed to any substance which may corrode refrigerant containing components, unless the components are constructed of materials which are inherently resistant to being corroded or are suitably protected against being so corroded.

Checks to electrical devices

Repair and maintenance to electrical components shall include initial safety checks and component inspection procedures. If a fault exists that could compromise safety, then no electrical supply shall be connected to the circuit until it is satisfactorily dealt with. If the fault cannot be corrected immediately but it is necessary to continue operation, an adequate temporary solution shall be used. This shall be reported to the owner of the equipment so all parties are advised.

Initial safety checks shall include:

- Capacitors are discharged: this shall be done in a safe manner to avoid possibility of sparking.
- No live electrical components and wiring are exposed while charging, recovering or purging the system.
- Continuity of earth bonding

Repairs to sealed components

Sealed electrical components shall be replaced.

Repair to intrinsically safe components

Intrinsically safe components must be replaced.

Cabbling

Check that cabling will not be subject to wear, corrosion, excessive pressure, vibration, sharp edges or any other adverse environmental effects. The check shall also take into account the effects of aging or continual vibration from sources such as compressors or fans.

Detection of flammable refrigerants

Under no circumstances shall potential sources of ignition be used in the searching for or detection of refrigerant leaks. A halide torch (or any other detector using a naked flame) shall not be used.

Leak detection methods

The following leak detection methods are deemed acceptable for all refrigerant systems.

Electronic leak detectors may be used to detect refrigerant leaks but, in the case of FLAMMABLE REFRIGERANTS, the sensitivity may not be adequate, or may need re-calibration. (Detection equipment shall be calibrated in a refrigerant-free area.) Ensure that the detector is not a potential source of ignition and is suitable for the refrigerant used. Leak detection equipment shall be set at a percentage of the LFL of the refrigerant and shall be calibrated to the refrigerant employed, and the appropriate percentage of gas (25 % maximum) is confirmed.

Leak detection fluids are also suitable for use with most refrigerants but the use of detergents containing chlorine shall be avoided as the chlorine may react with the refrigerant and corrode the copper pipe-work.

NOTE

- Examples of leak detection fluids are.
 - Bubble method.
 - Fluorescent method agents.

If a leak is suspected, all naked flames shall be removed / extinguished.

If a leakage of refrigerant is found which requires brazing, all of the refrigerant shall be recovered from the system, or isolated (by means of shut off valves) in a part of the system remote from the leak. Removal of refrigerant shall be according to removal and evacuation procedure.

Removal and evacuation

When breaking into the refrigerant circuit to make repairs – or for any other purpose – conventional procedures shall be used. However, for flammable refrigerants it is important that best practice be followed, since flammability is a consideration.

The following procedure shall be adhered to:

- Safely remove refrigerant following local and national regulations;
- Evacuate;
- Purge the circuit with inert gas (optional for A2L);
- Evacuate (optional for A2L);
- Continuously flush or purge with inert gas when using flame to open circuit; and
- Open the circuit.

The refrigerant charge shall be recovered into the correct recovery cylinders if venting is not allowed by local and national codes. For appliances containing flammable refrigerants, the system shall be purged with oxygen-free nitrogen to render the appliance safe for flammable refrigerants. This process might need to be repeated several times.

Compressed air or oxygen shall not be used for purging refrigerant systems.

For appliances containing flammable refrigerants, refrigerants purging shall be achieved by breaking the vacuum in the system with oxygen-free nitrogen and continuing to fill until the working pressure is achieved, then venting to atmosphere, and finally pulling down to a vacuum (optional for A2L). This process shall be repeated until no refrigerant is within the system (optional for A2L). When the final oxygen-free nitrogen charge is used, the system shall be vented down to atmospheric pressure to enable work to take place.

The outlet for the vacuum pump shall not be close to any potential ignition sources, and ventilation shall be available.

Charging procedures

In addition to conventional charging procedures, the following requirements shall be followed.

- Ensure that contamination of different refrigerants does not occur when using charging equipment. Hoses or lines shall be as short as possible to minimise the amount of refrigerant contained in them.
- Cylinders shall be kept in an appropriate position according to the instruction.
- Ensure that the refrigerating system is earthed prior to charging the system with refrigerant.
- Label the system when charging is complete (if not already).
- Extreme care shall be taken not to overfill the refrigerating system.

Prior to recharging the system, it shall be pressure tested with the appropriate purging gas.

The system shall be leak-tested on completion of charging but prior to commissioning. A follow up leak test shall be carried out prior to leaving the site.

Decommissioning

Before carrying out this procedure, it is essential that the technician is completely familiar with the equipment and all its detail.

It is recommended good practice that all refrigerants are recovered safely.

Prior to the task being carried out, an oil and refrigerant sample shall be taken in case analysis is required prior to re-use of recovered refrigerant.

It is essential that electrical power is available before the task is commenced.

- Become familiar with the equipment and its operation.
- Isolate system electrically.
- Before attempting the procedure ensure that:
 - Mechanical handling equipment is available, if required, for handling refrigerant cylinders
 - All personal protective equipment is available and being used correctly
 - The recovery process is supervised at all times by a competent person
 - Recovery equipment and cylinders conform to the appropriate standards.
- Pump down refrigerant system, if possible.
- If a vacuum is not possible, make a manifold so that refrigerant can be removed from various parts of the system.
- Make sure that cylinder is situated on the scales before recovery takes place.
- Start the recovery machine and operate in accordance with instructions.

- Do not overfill cylinders. (No more than 80 % volume liquid charge).
- Do not exceed the maximum working pressure of the cylinder, even temporarily.
- When the cylinders have been filled correctly and the process completed, make sure that the cylinders and the equipment are removed from site promptly and all isolation valves on the equipment are closed off.
- Recovered refrigerant shall not be charged into another refrigerating system unless it has been cleaned and checked.

Labelling

Equipment shall be labelled stating that it has been de-commissioned and emptied of refrigerant.

The label shall be dated and signed.

Ensure that there are labels on the equipment stating the equipment contains flammable refrigerant.

Recovery

When removing refrigerant from a system, either for servicing or decommissioning, it is recommended good practice that all refrigerants are removed safely.

When transferring refrigerant into cylinders, ensure that only appropriate refrigerant recovery cylinders are employed.

Ensure that the correct number of cylinders for holding the total system charge is available.

All cylinders to be used are designated for the recovered refrigerant and labelled for that refrigerant (i.e. special cylinders for the recovery of refrigerant).

Cylinders shall be complete with pressure-relief valve and associated shut-off valves in good working order.

Empty recovery cylinders are evacuated and, if possible, cooled before recovery occurs.

The recovery equipment shall be in good working order with a set of instructions concerning the equipment that is at hand and shall be suitable for the recovery of the flammable refrigerant.

If in doubt, the manufacturer should be consulted. In addition, a set of calibrated weighing scales shall be available and in good working order.

Hoses shall be complete with leak-free disconnect couplings and in good condition.

The recovered refrigerant shall be processed according to local legislation in the correct recovery cylinder, and the relevant waste transfer note arranged.

Do not mix refrigerants in recovery units and especially not in cylinders.

If compressor or compressor oils are to be removed, ensure that they have been evacuated to an acceptable level to make certain that flammable refrigerant does not remain within the lubricant.

The compressor body shall not be heated by an open flame or other ignition sources to accelerate this process.

When oil is drained from a system, it shall be carried out safely.

SAFETY PRECAUTIONS



To prevent injury to the user or other people and property damage, the following instructions must be followed.

- Incorrect operation due to ignoring instruction will cause harm or damage. The seriousness is classified by the following indications.

 **WARNING**
 This symbol indicates the possibility of death or serious injury.

 **CAUTION**
 This symbol indicates the possibility of injury or damage to properties only.

- Meanings of symbols used in this manual are as shown below.

	Be sure not to do.
	Be sure to follow the instruction.

WARNING **WARNING (Installation)**

- Do not use a defective or underrated circuit breaker. Use this appliance on a dedicated circuit.
 - There is risk of fire or electric shock.
- For electrical work, contact the dealer, seller, a qualified electrician, or an Authorized Service Center.
 - Do not disassemble or repair the product. There is risk of fire or electric shock.
- Always ground the product.
 - There is risk of fire or electric shock.
- Install the panel and the cover of control box securely.
 - There is risk of fire or electric shock.
- Always install a dedicated circuit and breaker.
 - Improper wiring or installation may cause fire or electric shock.
- Use the correctly rated breaker or fuse.
 - There is risk of fire or electric shock.
- Do not modify or extend the power cable.
 - There is risk of fire or electric shock.

- Do not install, remove, or re-install the unit by yourself (customer).
 - There is risk of fire, electric shock, explosion, or injury.
- Be cautious when unpacking and installing the product.
 - Sharp edges could cause injury. Be especially careful of the case edges and the fins on the condenser and evaporator.
- For installation, always contact the dealer or an Authorized Service Center.
 - There is risk of fire, electric shock, explosion, or injury.
- Do not install the product on a defective installation stand.
 - It may cause injury, accident, or damage to the product.
- Be sure the installation area does not deteriorate with age.
 - If the base collapses, the air conditioner could fall with it, causing property damage, product failure, and personal injury.
- Do not turn on the breaker or power under condition that front panel, cabinet, top cover, control box cover are removed or opened.
 - Otherwise, it may cause fire, electric shock, explosion or death.
- Use a vacuum pump or Inert (nitrogen) gas when doing leakage test or air purge. Do not compress air or Oxygen and Do not use Flammable gases. Otherwise, it may cause fire or explosion.
 - There is the risk of death, injury, fire or explosion.
- Do not place objects in direct proximity of the outside unit. Do not let leaves and other debris accumulate around the unit. Leaves are a hotbed for small animals, which can enter the unit. Once inside the unit, these animals can lead to the unit malfunctioning, and end up causing in smoke or fire when they make contact with electrical parts.
 - There is a risk of fire or electric shock.

WARNING (Operation)

- Do not let the air conditioner run for a long time when the humidity is very high and a door or a window is left open.
 - Moisture may condense and wet or damage furniture.
- Take care to ensure that power cable could not be pulled out or damaged during operation.
 - There is risk of fire or electric shock.
- Do not place anything on the power cable.
 - There is risk of fire or electric shock.
- Do not plug or unplug the power supply plug during operation.
 - There is risk of fire or electric shock.
- Do not touch (operate) the product with wet hands.
 - There is risk of fire or electrical shock.

20 SAFETY PRECAUTIONS

- Do not place a heater or other appliances near the power cable.
 - There is risk of fire and electric shock.
- Do not allow water to run into electric parts.
 - It may cause There is risk of fire, failure of the product, or electric shock.
- Do not store or use flammable gas or combustibles near the product.
 - There is risk of fire or failure of product.
- Do not use the product in a tightly closed space for a long time.
 - Oxygen deficiency could occur.
- When flammable gas leaks, turn off the gas and open a window for ventilation before turn the product on.
 - Do not use the telephone or turn switches on or off. There is risk of explosion or fire.
- If strange sounds, or smell or smoke comes from product. Turn the breaker off or disconnect the power supply cable.
 - There is risk of electric shock or fire.
- Stop operation and close the window in storm or hurricane. If possible, remove the product from the window before the hurricane arrives.
 - There is risk of property damage, failure of product, or electric shock.
- Do not open the inlet grill of the product during operation. (Do not touch the electrostatic filter, if the unit is so equipped.)
 - There is risk of physical injury, electric shock, or product failure.
- When the product is soaked (flooded or submerged), contact an Authorized Service Center.
 - There is risk of fire or electric shock.
- Be cautious that water could not enter the product.
 - There is risk of fire, electric shock, or product damage.
- Ventilate the product from time to time when operating it together with a stove, etc.
 - There is risk of fire or electric shock.
- Turn the main power off when cleaning or maintaining the product.
 - There is risk of electric shock.
- When the product is not be used for a long time, disconnect the power supply plug or turn off the breaker.
 - There is risk of product damage or failure, or unintended operation.
- Take care to ensure that nobody could step on or fall onto the outdoor unit.
 - This could result in personal injury and product damage.

CAUTION

CAUTION (Installation)

- Always check for gas (refrigerant) leakage after installation or repair of product.
 - Low refrigerant levels may cause failure of product.
- Install the drain hose to ensure that water is drained away properly.
 - A bad connection may cause water leakage.
- Keep level even when installing the product.
 - To avoid vibration or water leakage.
- Do not install the product where the noise or hot air from the outdoor unit could damage the neighborhoods.
 - It may cause a problem for your neighbors.
- Use two or more people to lift and transport the product.
 - Avoid personal injury.
- Do not install the product where it will be exposed to sea wind (salt spray) directly.
 - It may cause corrosion on the product. Corrosion, particularly on the condenser and evaporator fins, could cause product malfunction or inefficient operation.
- Do not install the unit in potentially explosive atmospheres.
- The installation of pipe-work shall be kept to a minimum.
- Any person who is involved with working on or breaking into a refrigerant circuit should hold a current valid certificate from an industry-accredited assessment authority, which authorises their competence to handle refrigerants safely in accordance with an industry recognised assessment specification.
- When mechanical connectors are reused indoors, sealing parts shall be renewed.
- When flared joints are reused indoors, the flare part shall be re-fabricated.

CAUTION (Operation)

- Do not expose the skin directly to cool air for long periods of time. (Don't sit in the draft.)
- Avoid excessive cooling and perform ventilation sometimes.
 - This could harm to your health.
- Do not use the product for special purposes, such as preserving foods, works of art, etc. It is a consumer air conditioner, not a precision refrigeration system.
 - There is risk of damage or loss of property.
- Do not block the inlet or outlet of air flow.
- Do not block or place obstacles around the flow inlet or outlet.
 - It may cause product a failure or an accident.
- Use a soft cloth to clean. Do not use harsh detergents, solvents, etc.
 - There is risk of fire, electric shock, or damage to the plastic parts of the product.
 - The appearance of the air conditioner may deteriorate, change color, or develop surface flaws.
- Do not touch the metal parts of the product when removing the air filter. They are very sharp!
 - There is risk of personal injury.
- Do not step on or put anything on the product. (outdoor units)
 - There is risk of personal injury and failure of product.

22 SAFETY PRECAUTIONS

- Always insert the filter securely. Clean the filter every two weeks or more often if necessary.
 - A dirty filter reduces the efficiency of the air conditioner and could cause product malfunction or damage.
- Do not insert hands or other objects through the air inlet or outlet while the product is operated.
 - There are sharp and moving parts that could cause personal injury.
- Do not drink the water drained from the product.
 - It is not sanitary and could cause serious health issues.
- Use a firm stool or ladder when cleaning or maintaining the product.
 - Be careful and avoid personal injury.
- Replace the all batteries in the remote control with new ones of the same type. Do not mix old and new batteries or different types of batteries.
 - There is risk of fire or explosion.
- Do not recharge or disassemble the batteries. Do not dispose of batteries in a fire.
 - They may burn or explode.
- If the liquid from the batteries gets onto your skin or clothes, wash it well with clean water. Do not use the remote if the batteries have leaked.
 - The chemicals in batteries could cause burns or other health hazards.
- If you eat the liquid from the batteries, brush your teeth and see doctor. Do not use the remote if the batteries have leaked.
 - The chemicals in batteries could cause burns or other health hazards.
- Do not use an appliance for special purposes such as preserving animals vegetables, precision machine, or art articles.
 - It could damage your properties.
- This appliance is not intended for the purposes of cooling INFORMATION TECHNOLOGY EQUIPMENT
- Servicing shall only be performed as recommended by the equipment manufacturer. Maintenance and repair requiring the assistance of other skilled personnel shall be carried out under the supervision of the person competent in the use of flammable refrigerants.

CAUTION (Service)

- Servicing shall be performed only as recommended by the manufacturer.

MINIMUM FLOOR AREA

The appliance shall be installed, operated and stored in a room with a floor area larger than the minimum floor area. Installers must use refrigerant charge amounts that meet the requirements to comply with use conditions required in SNAP Rules.

In this manual, provide a simple method to find minimum floor area in table. For more accurate value, use LATS or-R Checker.

Single-Split System(UL 60335-2-40:2019 Edition 3)

- Minimum floor area for Single Split System(UL 60335-2-40:2019 Edition 3)
- Minimum total conditioned room area (UL 60335-2-40:2019 Edition 3)

Multi-Split System (UL 60335-2-40:2019 Edition 3)

- Minimum floor area for Multi-Split System (UL 60335-2-40:2019 Edition 3)

ETRS Unit(UL 60335-2-40:2022 Edition 4)

- Minimum floor area for ETRS unit (UL 60335-2-40:2022 Edition 4)
- Minimum total conditioned room area (UL 60335-2-40:2022 Edition 4)

Minimum floor area for Single-Split System (UL 60335-2-40:2019 Edition 3)

The following instructions apply when only one indoor unit is connected to an outdoor unit.

- Use the <Table1> to determine the minimum floor area with m and h.
- If m is not in table, use the next larger value.
- m : Total refrigerant charge in system
- Total refrigerant charge in system : factory refrigerant charge +additional refrigerant charge.
- h : Installed height.
- A_{min} : Minimum floor area

NOTE

- If the opening height of discharge of intake duct outlet is lower than the unit installation height, the installation height is the lower opening height of duct outlet.

<Table 1> : Table for Single-Split System.
Maximum of m is 15.91 kg (35.07 lbs)

m		Minimum floor area (Installed Height)									
		A _{min} (h<0.6 m, 1.97 ft)		A _{min} (h≥0.8 m, 2.62 ft)		A _{min} (h≥1.0 m, 3.28 ft)		A _{min} (h≥1.2 m, 3.94 ft)		A _{min} (h≥1.4 m, 4.59 ft)	
kg	lbs	m ²	ft ²	m ²	ft ²	m ²	ft ²	m ²	ft ²	m ²	ft ²
≤ 1.83	≤ 4.04	-	-	-	-	-	-	-	-	-	-
1.84	4.05	40.09	431.53	30.07	323.68	24.06	258.98	17.19	185.04	15.04	161.89
2.00	4.40	43.58	469.10	32.68	351.77	26.15	281.48	18.68	201.07	16.34	175.89
2.20	4.85	47.94	516.03	35.95	386.97	28.76	309.58	20.55	221.20	17.98	193.54
2.40	5.29	52.29	562.85	39.22	422.17	31.38	337.78	22.41	241.22	19.61	211.09
2.60	5.73	58.01	624.42	42.49	457.36	33.99	365.87	24.28	261.35	21.25	228.74
2.80	6.17	67.28	724.20	45.76	492.56	36.61	394.07	26.15	281.48	22.88	246.28
3.00	6.61	77.23	831.30	49.02	527.65	39.22	422.17	28.02	301.61	24.51	263.83
3.20	7.05	87.87	945.83	52.29	562.85	41.84	450.37	29.88	321.63	26.15	281.48
3.40	7.49	99.20	1067.78	55.80	600.63	44.45	478.46	31.75	341.76	27.78	299.03
3.60	7.93	111.21	1197.06	62.56	673.40	47.06	506.55	33.62	361.89	29.42	316.68
3.80	8.37	123.91	1333.76	69.70	750.25	49.68	534.76	35.49	382.02	31.05	334.22
4.00	8.81	137.29	1477.78	77.23	831.30	52.29	562.85	37.35	402.04	32.68	351.77
4.20	9.25	151.37	1629.34	85.15	916.55	54.91	591.05	39.22	422.17	34.32	369.42
4.40	9.70	166.12	1788.11	93.45	1005.89	59.81	643.79	41.09	442.29	35.95	386.97
4.60	10.14	181.57	1954.41	102.13	1099.32	65.37	703.64	42.96	462.42	37.59	404.62
4.80	10.58	197.70	2128.03	111.21	1197.06	71.18	766.18	44.82	482.44	39.22	422.17
5.00	11.02	214.52	2309.08	120.67	1298.89	77.23	831.30	46.69	502.57	40.85	439.71
5.20	11.46	232.02	2497.45	130.51	1404.80	83.53	899.11	48.56	522.70	42.49	457.36
5.40	11.90	250.21	2693.24	140.75	1515.03	90.08	969.62	50.43	542.83	44.12	474.91
5.60	12.34	269.09	2896.47	151.37	1629.34	96.88	1042.81	52.29	562.85	45.76	492.56
5.80	12.78	288.65	3107.01	162.37	1747.74	103.92	1118.59	54.16	582.98	47.39	510.11
6.00	13.22	308.90	3324.98	173.76	1870.34	111.21	1197.06	56.74	610.75	49.02	527.65
6.20	13.66	329.84	3550.37	185.54	1997.14	118.75	1278.22	60.59	652.19	50.66	545.30
6.40	14.10	351.46	3783.09	197.70	2128.03	126.53	1361.96	64.56	694.92	52.29	562.85
6.60	14.55	373.77	4023.23	210.25	2263.12	134.56	1448.40	68.66	739.06	53.93	580.50
6.80	14.99	396.77	4270.80	223.18	2402.29	142.84	1537.52	72.88	784.48	55.80	600.63
7.00	15.43	420.45	4525.69	236.51	2545.78	151.37	1629.34	77.23	831.30	59.13	636.48
7.20	15.87	444.82	4788.01	250.21	2693.24	160.14	1723.74	81.71	879.52	62.56	673.40
7.40	16.31	469.87	5057.64	264.31	2845.01	169.16	1820.83	86.31	929.04	66.08	711.28
7.60	16.75	495.62	5334.81	278.79	3000.88	178.43	1920.61	91.04	979.95	69.70	750.25
7.80	17.19	522.04	5619.20	293.65	3160.83	187.94	2022.97	95.89	1032.16	73.42	790.29
8.00	17.63	549.16	5911.11	308.90	3324.98	197.70	2128.03	100.87	1085.76	77.23	831.30
8.20	18.07	576.96	6210.35	324.54	3493.32	207.71	2235.78	105.98	1140.76	81.14	873.39
8.40	18.51	605.45	6517.01	340.57	3665.87	217.96	2346.11	111.21	1197.06	85.15	916.55

26 MINIMUM FLOOR AREA

m		Minimum floor area (Installed Height)									
		A _{min} (h<0.6 m, 1.97 ft)		A _{min} (h≥0.8 m, 2.62 ft)		A _{min} (h≥1.0 m, 3.28 ft)		A _{min} (h≥1.2 m, 3.94 ft)		A _{min} (h≥1.4 m, 4.59 ft)	
kg	lbs	m ²	ft ²	m ²	ft ²	m ²	ft ²	m ²	ft ²	m ²	ft ²
8.60	18.95	634.62	6831.00	356.98	3842.51	228.47	2459.24	116.57	1254.75	89.25	960.68
8.80	19.40	664.48	7152.41	373.77	4023.23	239.22	2574.95	122.05	1313.74	93.45	1005.89
9.00	19.84	695.03	7481.25	390.96	4208.26	250.21	2693.24	127.66	1374.13	97.74	1052.07
9.20	20.28	726.26	7817.40	408.52	4397.28	261.46	2814.34	133.40	1435.91	102.13	1099.32
9.40	20.72	758.18	8160.99	426.48	4590.60	272.95	2938.01	139.26	1498.99	106.62	1147.65
9.60	21.16	790.79	8512.00	444.82	4788.01	284.69	3064.38	145.25	1563.46	111.21	1197.06
9.80	21.60	824.08	8870.33	463.55	4989.62	296.67	3193.33	151.37	1629.34	115.89	1247.43
10.00	22.04	858.06	9236.09	482.66	5195.31	308.90	3324.98	157.61	1696.50	120.67	1298.89
10.20	22.48	892.72	9609.16	502.16	5405.21	321.38	3459.31	163.97	1764.96	125.54	1351.31
10.40	22.92	928.07	9989.67	522.04	5619.20	334.11	3596.34	170.47	1834.93	130.51	1404.80
10.60	23.36	964.11	10377.60	542.32	5837.49	347.08	3735.94	177.09	1906.19	135.58	1459.38
10.80	23.80	1000.84	10772.96	562.97	6059.76	360.30	3878.24	183.83	1978.73	140.75	1515.03
11.00	24.25	1038.25	11175.63	584.02	6286.34	373.77	4023.23	190.70	2052.68	146.01	1571.64
11.20	24.69	1076.35	11585.74	605.45	6517.01	387.49	4170.91	197.70	2128.03	151.37	1629.34
11.40	25.13	1115.13	12003.16	627.26	6751.78	401.45	4321.18	204.82	2204.67	156.82	1688.00
11.60	25.57	1154.60	12428.02	649.47	6990.84	415.66	4474.13	212.07	2282.71	162.37	1747.74
11.80	26.01	1194.76	12860.29	672.05	7233.89	430.12	4629.78	219.45	2362.15	168.02	1808.56
12.00	26.45	1235.60	13299.89	695.03	7481.25	444.82	4788.01	226.95	2442.87	173.76	1870.34
12.20	26.89	1277.13	13746.92	718.39	7732.69	459.77	4948.93	234.58	2525.00	179.60	1933.20
12.40	27.33	1319.35	14201.37	742.13	7988.23	474.97	5112.54	242.33	2608.42	185.54	1997.14
12.60	27.77	1362.25	14663.14	766.27	8248.07	490.41	5278.73	250.21	2693.24	191.57	2062.05
12.80	28.21	1405.84	15132.34	790.79	8512.00	506.11	5447.73	258.22	2779.46	197.70	2128.03
13.00	28.66	1450.11	15608.86	815.69	8780.02	522.04	5619.20	266.35	2866.97	203.93	2195.09
13.20	29.10	1495.08	16092.91	840.98	9052.24	538.23	5793.46	274.61	2955.88	210.25	2263.12
13.40	29.54	1540.72	16584.18	866.66	9328.66	554.66	5970.32	282.99	3046.08	216.67	2332.22
13.60	29.98	1587.06	17082.98	892.72	9609.16	571.34	6149.86	291.50	3137.68	223.18	2402.29
13.80	30.42	1634.08	17589.10	919.17	9893.87	588.27	6332.09	300.14	3230.69	229.80	2473.55
14.00	30.86	1681.79	18102.64	946.01	10182.77	605.45	6517.01	308.90	3324.98	236.51	2545.78
14.20	31.30	1730.18	18623.51	973.23	10475.77	622.87	6704.52	317.79	3420.67	243.31	2618.97
14.40	31.74	1779.26	19151.80	1000.84	10772.96	640.54	6894.72	326.81	3517.76	250.21	2693.24
14.60	32.18	1829.03	19687.52	1028.83	11074.24	658.45	7087.50	335.95	3616.14	257.21	2768.59
14.80	32.62	1879.48	20230.56	1057.21	11379.72	676.62	7283.08	345.22	3715.92	264.31	2845.01
15.00	33.06	1930.62	20781.03	1085.98	11689.40	695.03	7481.25	354.61	3817.00	271.50	2922.41
15.20	33.51	1982.45	21338.92	1115.13	12003.16	713.69	7682.10	364.13	3919.47	278.79	3000.88
15.40	33.95	2034.96	21904.13	1144.67	12321.13	732.59	7885.54	373.77	4023.23	286.17	3080.31
15.60	34.39	2088.16	22476.77	1174.59	12643.19	751.74	8091.67	383.54	4128.40	293.65	3160.83
15.80	34.83	2142.05	23056.84	1204.90	12969.44	771.14	8300.49	393.44	4234.96	301.23	3242.42
15.91	35.07	2171.98	23379.00	1221.74	13150.70	781.92	8416.52	398.94	4294.16	305.44	3287.73

m		Minimum floor area (Installed Height)							
		A _{min} (h≥1.6 m, 5.25 ft)		A _{min} (h≥1.8 m, 5.91 ft)		A _{min} (h≥2.0 m, 6.56 ft)		A _{min} (h≥2.2 m, 7.22 ft)	
kg	lbs	m ²	ft ²	m ²	ft ²	m ²	ft ²	m ²	ft ²
≤ 1.83	≤ 4.04	-	-	-	-	-	-	-	-
1.84	4.05	15.04	161.89	13.37	143.92	12.03	129.49	10.94	117.76
2.00	4.40	16.34	175.89	14.53	156.40	13.08	140.80	11.89	127.99
2.20	4.85	17.98	193.54	15.98	172.01	14.38	154.79	13.08	140.80
2.40	5.29	19.61	211.09	17.43	187.62	15.69	168.89	14.27	153.61
2.60	5.73	21.25	228.74	18.89	203.34	17.00	182.99	15.45	166.31
2.80	6.17	22.88	246.28	20.34	218.94	18.31	197.09	16.64	179.12
3.00	6.61	24.51	263.83	21.79	234.55	19.61	211.09	17.83	191.93
3.20	7.05	26.15	281.48	23.24	250.16	20.92	225.19	19.02	204.73
3.40	7.49	27.78	299.03	24.70	265.87	22.23	239.29	20.21	217.54
3.60	7.93	29.42	316.68	26.15	281.48	23.53	253.28	21.40	230.35
3.80	8.37	31.05	334.22	27.60	297.09	24.84	267.38	22.58	243.05
4.00	8.81	32.68	351.77	29.05	312.70	26.15	281.48	23.77	255.86
4.20	9.25	34.32	369.42	30.51	328.41	27.46	295.58	24.96	268.67
4.40	9.70	35.95	386.97	31.96	344.02	28.76	309.58	26.15	281.48
4.60	10.14	37.59	404.62	33.41	359.63	30.07	323.68	27.34	294.29
4.80	10.58	39.22	422.17	34.86	375.23	31.38	337.78	28.53	307.10
5.00	11.02	40.85	439.71	36.32	390.95	32.68	351.77	29.71	319.80
5.20	11.46	42.49	457.36	37.77	406.56	33.99	365.87	30.90	332.61
5.40	11.90	44.12	474.91	39.22	422.17	35.30	379.97	32.09	345.42
5.60	12.34	45.76	492.56	40.67	437.77	36.61	394.07	33.28	358.23
5.80	12.78	47.39	510.11	42.13	453.49	37.91	408.06	34.47	371.04
6.00	13.22	49.02	527.65	43.58	469.10	39.22	422.17	35.66	383.85
6.20	13.66	50.66	545.30	45.03	484.70	40.53	436.27	36.84	396.55
6.40	14.10	52.29	562.85	46.48	500.31	41.84	450.37	38.03	409.36
6.60	14.55	53.93	580.50	47.94	516.03	43.14	464.36	39.22	422.17
6.80	14.99	55.80	600.63	49.39	531.63	44.45	478.46	40.41	434.97
7.00	15.43	59.13	636.48	50.84	547.24	45.76	492.56	41.60	447.78
7.20	15.87	62.56	673.40	52.29	562.85	47.06	506.55	42.79	460.59
7.40	16.31	66.08	711.28	53.75	578.57	48.37	520.66	43.97	473.29
7.60	16.75	69.70	750.25	55.20	594.17	49.68	534.76	45.16	486.10
7.80	17.19	73.42	790.29	58.01	624.42	50.99	548.86	46.35	498.91
8.00	17.63	77.23	831.30	61.02	656.82	52.29	562.85	47.54	511.72
8.20	18.07	81.14	873.39	64.11	690.08	53.60	576.95	48.73	524.53
8.40	18.51	85.15	916.55	67.28	724.20	54.91	591.05	49.92	537.34
8.60	18.95	89.25	960.68	70.52	759.08	57.12	614.84	51.10	550.04

28 MINIMUM FLOOR AREA

m		Minimum floor area (Installed Height)							
		A_{min} ($h \geq 1.6$ m, 5.25 ft)		A_{min} ($h \geq 1.8$ m, 5.91 ft)		A_{min} ($h \geq 2.0$ m, 6.56 ft)		A_{min} ($h \geq 2.2$ m, 7.22 ft)	
kg	lbs	m ²	ft ²	m ²	ft ²	m ²	ft ²	m ²	ft ²
8.80	19.40	93.45	1005.89	73.84	794.81	59.81	643.79	52.29	562.85
9.00	19.84	97.74	1052.07	77.23	831.30	62.56	673.40	53.48	575.66
9.20	20.28	102.13	1099.32	80.70	868.65	65.37	703.64	54.67	588.47
9.40	20.72	106.62	1147.65	84.25	906.86	68.24	734.53	56.40	607.09
9.60	21.16	111.21	1197.06	87.87	945.83	71.18	766.18	58.82	633.14
9.80	21.60	115.89	1247.43	91.57	985.66	74.17	798.36	61.30	659.83
10.00	22.04	120.67	1298.89	95.34	1026.24	77.23	831.30	63.83	687.07
10.20	22.48	125.54	1351.31	99.20	1067.78	80.35	864.89	66.41	714.84
10.40	22.92	130.51	1404.80	103.12	1109.98	83.53	899.11	69.03	743.04
10.60	23.36	135.58	1459.38	107.13	1153.14	86.77	933.99	71.72	771.99
10.80	23.80	140.75	1515.03	111.21	1197.06	90.08	969.62	74.45	801.38
11.00	24.25	146.01	1571.64	115.37	1241.84	93.45	1005.89	77.23	831.30
11.20	24.69	151.37	1629.34	119.60	1287.37	96.88	1042.81	80.06	861.76
11.40	25.13	156.82	1688.00	123.91	1333.76	100.37	1080.38	82.95	892.87
11.60	25.57	162.37	1747.74	128.29	1380.91	103.92	1118.59	85.88	924.41
11.80	26.01	168.02	1808.56	132.76	1429.02	107.53	1157.45	88.87	956.59
12.00	26.45	173.76	1870.34	137.29	1477.78	111.21	1197.06	91.91	989.32
12.20	26.89	179.60	1933.20	141.91	1527.51	114.95	1237.32	95.00	1022.58
12.40	27.33	185.54	1997.14	146.60	1577.99	118.75	1278.22	98.14	1056.38
12.60	27.77	191.57	2062.05	151.37	1629.34	122.61	1319.77	101.33	1090.71
12.80	28.21	197.70	2128.03	156.21	1681.44	126.53	1361.96	104.57	1125.59
13.00	28.66	203.93	2195.09	161.13	1734.39	130.51	1404.80	107.86	1161.00
13.20	29.10	210.25	2263.12	166.12	1788.11	134.56	1448.40	111.21	1197.06
13.40	29.54	216.67	2332.22	171.20	1842.79	138.67	1492.64	114.60	1233.55
13.60	29.98	223.18	2402.29	176.34	1898.11	142.84	1537.52	118.05	1270.68
13.80	30.42	229.80	2473.55	181.57	1954.41	147.07	1583.05	121.55	1308.36
14.00	30.86	236.51	2545.78	186.87	2011.46	151.37	1629.34	125.10	1346.57
14.20	31.30	243.31	2618.97	192.25	2069.37	155.72	1676.16	128.70	1385.32
14.40	31.74	250.21	2693.24	197.70	2128.03	160.14	1723.74	132.35	1424.61
14.60	32.18	257.21	2768.59	203.23	2187.55	164.62	1771.96	136.05	1464.44
14.80	32.62	264.31	2845.01	208.84	2247.94	169.16	1820.83	139.80	1504.80
15.00	33.06	271.50	2922.41	214.52	2309.08	173.76	1870.34	143.60	1545.70
15.20	33.51	278.79	3000.88	220.28	2371.08	178.43	1920.61	147.46	1587.25
15.40	33.95	286.17	3080.31	226.11	2433.83	183.15	1971.42	151.37	1629.34
15.60	34.39	293.65	3160.83	232.02	2497.45	187.94	2022.97	155.32	1671.86
15.80	34.83	301.23	3242.42	238.01	2561.92	192.79	2075.18	159.33	1715.02
15.91	35.07	305.44	3287.73	241.34	2597.77	195.48	2104.13	161.56	1739.02

Minimum total conditioned room area (UL 60335-2-40:2019 Edition 3)

The following instructions apply when only one indoor unit is connected to an outdoor unit and connected via an air duct system to one or more rooms. If the Leak Detection System is activated, indoor units operate with maximum air flow rate. If maximum air flow rate of ducted indoor unit is more than minimum circulation airflow, minimum floor area can be replaced by minimum total conditioned room area. Height of room where indoor units are installed must be higher than 2.0 m (6.56 ft).

- * Maximum air flow rate of ducted indoor unit is announced in EM or E-SVC Manual spec sheet.
- * Low static duct shall be connected to one room.
- Use the <Table 2> to determine the minimum total conditioned room area with m.
- If m is not in table, use the next larger value.
- m : Total refrigerant charge in system.
- Total refrigerant charge in system : factory refrigerant charge +additional refrigerant charge.
- Q_{min} : Minimum circulation air flow.
- TA_{min} : Minimum total conditioned room area.
- EM : Engineering Manual.
- E-SVC Manual : Service Manual(Exploded View)

<Table 2> : Table for Single-Split System with duct work.

Maximum of m is 15.91 kg (35.07 lbs)

m		Q _{min}		TA _{min}	
kg	lbs	cmm	cfm	m ²	ft ²
≤ 1.83	≤ 4.04	-	-	-	-
1.84	4.05	6.1	215.5	12.03	129.45
2.00	4.40	6.6	233.1	13.07	140.71
2.20	4.85	7.2	254.3	14.38	154.78
2.40	5.29	7.9	279.0	15.69	168.85
2.60	5.73	8.5	300.2	16.99	182.92
2.80	6.17	9.2	324.9	18.30	196.99
3.00	6.61	9.9	349.7	19.61	211.06
3.20	7.05	10.5	370.9	20.92	225.13
3.40	7.49	11.2	395.6	22.22	239.20
3.60	7.93	11.8	416.8	23.53	253.27
3.80	8.37	12.5	441.5	24.84	267.34
4.00	8.81	13.1	462.7	26.14	281.41
4.20	9.25	13.8	487.4	27.45	295.48

m		Q _{min}		TA _{min}	
kg	lbs	cmm	cfm	m ²	ft ²
4.40	9.70	14.4	508.6	28.76	309.56
4.60	10.14	15.1	533.3	30.07	323.63
4.80	10.58	15.7	554.5	31.37	337.70
5.00	11.02	16.4	579.2	32.68	351.77
5.20	11.46	17.0	600.4	33.99	365.84
5.40	11.90	17.7	625.1	35.29	379.91
5.60	12.34	18.4	649.8	36.60	393.98
5.80	12.78	19.0	671.0	37.91	408.05
6.00	13.22	19.7	695.7	39.22	422.12
6.20	13.66	20.3	716.9	40.52	436.19
6.40	14.10	21.0	741.7	41.83	450.26
6.60	14.55	21.6	762.8	43.14	464.33
6.80	14.99	22.3	787.6	44.44	478.40
7.00	15.43	22.9	808.8	45.75	492.47

30 MINIMUM FLOOR AREA

m		Q _{min}		TA _{min}	
kg	lbs	cmm	cfm	m ²	ft ²
7.20	15.87	23.6	833.5	47.06	506.54
7.40	16.31	24.2	854.7	48.37	520.61
7.60	16.75	24.9	879.4	49.67	534.68
7.80	17.19	25.5	900.6	50.98	548.75
8.00	17.63	26.2	925.3	52.29	562.82
8.20	18.07	26.8	946.5	53.59	576.89
8.40	18.51	27.5	971.2	54.90	590.96
8.60	18.95	28.2	995.9	56.21	605.04
8.80	19.40	28.8	1017.1	57.52	619.11
9.00	19.84	29.5	1041.8	58.82	633.18
9.20	20.28	30.1	1063.0	60.13	647.25
9.40	20.72	30.8	1087.7	61.44	661.32
9.60	21.16	31.4	1108.9	62.75	675.39
9.80	21.60	32.1	1133.7	64.05	689.46
10.00	22.04	32.7	1154.8	65.36	703.53
10.20	22.48	33.4	1179.6	66.67	717.60
10.40	22.92	34.0	1200.7	67.97	731.67
10.60	23.36	34.7	1225.5	69.28	745.74
10.80	23.80	35.3	1246.7	70.59	759.81
11.00	24.25	36.0	1271.4	71.90	773.88
11.20	24.69	36.7	1296.1	73.20	787.95
11.40	25.13	37.3	1317.3	74.51	802.02
11.60	25.57	38.0	1342.0	75.82	816.09

m		Q _{min}		TA _{min}	
kg	lbs	cmm	cfm	m ²	ft ²
11.80	26.01	38.6	1363.2	77.12	830.16
12.00	26.45	39.3	1387.9	78.43	844.23
12.20	26.89	39.9	1409.1	79.74	858.30
12.40	27.33	40.6	1433.8	81.05	872.37
12.60	27.77	41.2	1455.0	82.35	886.44
12.80	28.21	41.9	1479.7	83.66	900.52
13.00	28.66	42.5	1500.9	84.97	914.59
13.20	29.10	43.2	1525.6	86.27	928.66
13.40	29.54	43.8	1546.8	87.58	942.73
13.60	29.98	44.5	1571.6	88.89	956.80
13.80	30.42	45.1	1592.7	90.20	970.87
14.00	30.86	45.8	1617.5	91.50	984.94
14.20	31.30	46.5	1642.2	92.81	999.01
14.40	31.74	47.1	1663.4	94.12	1013.08
14.60	32.18	47.8	1688.1	95.42	1027.15
14.80	32.62	48.4	1709.3	96.73	1041.22
15.00	33.06	49.1	1734.0	98.04	1055.29
15.20	33.51	49.7	1755.2	99.35	1069.36
15.40	33.95	50.4	1779.9	100.65	1083.43
15.60	34.39	51.0	1801.1	101.96	1097.50
15.80	34.83	51.7	1825.8	103.27	1111.57
15.91	35.07	52.0	1836.4	103.99	1119.31

Minimum floor area for Multi-Split System (UL 60335-2-40:2019 Edition 3)

The following instructions apply when two or more independently controlled indoor units on a single refrigeration system. Height of room where indoor units are installed must be higher than 2.0 m (6.56 ft).

- Use the <Table 3> to determine the minimum floor area with m .
- If m is not in table, use the next larger value.
- m : Total refrigerant charge in system.
- Total refrigerant charge in system : factory refrigerant charge + additional refrigerant charge.
- A_{min} : minimum floor area.

NOTE

- Multi F and Multi V Indoor units shall not be used in a sealed room without ventilation to the outside of the room.
- Multi F and Multi V indoor units shall not be installed on the lowest underground floor of the building.

32 MINIMUM FLOOR AREA

<Table 3> : Table for Multi-Split System

Maximum of m is product of 15.91 kg (35.07 lbs) and Number of Indoor units, not exceed 63.64 kg (140.30 lbs)

Minimum floor area			
m		A _{min}	
kg	lbs	m ²	ft ²
≤ 1.83	≤ 4.04	-	-
1.85	4.07	12.10	130.25
2.00	4.40	13.08	140.80
2.20	4.85	14.38	154.79
2.40	5.29	15.69	168.89
2.60	5.73	17.00	182.99
2.80	6.17	18.31	197.09
3.00	6.61	19.61	211.09
3.20	7.05	20.92	225.19
3.40	7.49	22.23	239.29
3.60	7.93	23.53	253.28
3.80	8.37	24.84	267.38
4.00	8.81	26.15	281.48
4.20	9.25	27.46	295.58
4.40	9.70	28.76	309.58
4.60	10.14	30.07	323.68
4.80	10.58	31.38	337.78
5.00	11.02	32.68	351.77
5.20	11.46	33.99	365.87
5.40	11.90	35.30	379.97
5.60	12.34	36.61	394.07
5.80	12.78	37.91	408.06
6.00	13.22	39.22	422.17
6.20	13.66	40.53	436.27
6.40	14.10	41.84	450.37
6.60	14.55	43.14	464.36
6.80	14.99	44.45	478.46
7.00	15.43	45.76	492.56
7.20	15.87	47.06	506.55
7.40	16.31	48.37	520.66
7.60	16.75	49.68	534.76
7.80	17.19	50.99	548.86
8.00	17.63	52.29	562.85
8.20	18.07	53.60	576.95

Minimum floor area			
m		A _{min}	
kg	lbs	m ²	ft ²
8.40	18.51	54.91	591.05
8.60	18.95	56.21	605.04
8.80	19.40	57.52	619.15
9.00	19.84	58.83	633.25
9.20	20.28	60.14	647.35
9.40	20.72	61.44	661.34
9.60	21.16	62.75	675.44
9.80	21.60	64.06	689.54
10.00	22.04	65.36	703.53
10.20	22.48	66.67	717.63
10.40	22.92	67.98	731.74
10.60	23.36	69.29	745.84
10.80	23.80	70.59	759.83
11.00	24.25	71.90	773.93
11.20	24.69	73.21	788.03
11.40	25.13	74.51	802.02
11.60	25.57	75.82	816.12
11.80	26.01	77.13	830.23
12.00	26.45	78.44	844.33
12.20	26.89	79.74	858.32
12.40	27.33	81.05	872.42
12.60	27.77	82.36	886.52
12.80	28.21	83.67	900.62
13.00	28.66	84.97	914.61
13.20	29.10	86.28	928.72
13.40	29.54	87.59	942.82
13.60	29.98	88.89	956.81
13.80	30.42	90.20	970.91
14.00	30.86	91.51	985.01
14.20	31.30	92.82	999.11
14.40	31.74	94.12	1013.10
14.60	32.18	95.43	1027.20
14.80	32.62	96.74	1041.31
15.00	33.06	98.04	1055.30

Minimum floor area			
m		A _{min}	
kg	lbs	m ²	ft ²
15.20	33.51	99.35	1069.40
15.40	33.95	100.66	1083.50
15.60	34.39	101.97	1097.60
15.80	34.83	103.27	1111.59
16.00	35.27	104.58	1125.69
16.20	35.71	105.89	1139.80
16.40	36.15	107.19	1153.79
16.60	36.59	108.50	1167.89
16.80	37.03	109.81	1181.99
17.00	37.47	111.12	1196.09
17.20	37.91	112.42	1210.08
17.40	38.36	113.73	1224.18
17.60	38.80	115.04	1238.29
17.80	39.24	116.34	1252.28
18.00	39.68	117.65	1266.38
18.20	40.12	118.96	1280.48
18.40	40.56	120.27	1294.58
18.60	41.00	121.57	1308.57
18.80	41.44	122.88	1322.67
19.00	41.88	124.19	1336.78
19.20	42.32	125.50	1350.88
19.40	42.76	126.80	1364.87
19.60	43.21	128.11	1378.97
19.80	43.65	129.42	1393.07
20.00	44.09	130.72	1407.06
20.20	44.53	132.03	1421.16
20.40	44.97	133.34	1435.26
20.60	45.41	134.65	1449.37
20.80	45.85	135.95	1463.36
21.00	46.29	137.26	1477.46
21.20	46.73	138.57	1491.56
21.40	47.17	139.87	1505.55
21.60	47.61	141.18	1519.65
21.80	48.06	142.49	1533.75
22.00	48.50	143.80	1547.86
22.20	48.94	145.10	1561.85
22.40	49.38	146.41	1575.95
22.60	49.82	147.72	1590.05
22.80	50.26	149.02	1604.04
23.00	50.70	150.33	1618.14
23.20	51.14	151.64	1632.24

Minimum floor area			
m		A _{min}	
kg	lbs	m ²	ft ²
23.40	51.58	152.95	1646.35
23.60	52.02	154.25	1660.34
23.80	52.47	155.56	1674.44
24.00	52.91	156.87	1688.54
24.20	53.35	158.17	1702.53
24.40	53.79	159.48	1716.63
24.60	54.23	160.79	1730.73
24.80	54.67	162.10	1744.83
25.00	55.11	163.40	1758.83
25.20	55.55	164.71	1772.93
25.40	55.99	166.02	1787.03
25.60	56.43	167.33	1801.13
25.80	56.87	168.63	1815.12
26.00	57.32	169.94	1829.22
26.20	57.76	171.25	1843.32
26.40	58.20	172.55	1857.32
26.60	58.64	173.86	1871.42
26.80	59.08	175.17	1885.52
27.00	59.52	176.48	1899.62
27.20	59.96	177.78	1913.61
27.40	60.40	179.09	1927.71
27.60	60.84	180.40	1941.81
27.80	61.28	181.70	1955.81
28.00	61.72	183.01	1969.91
28.20	62.17	184.32	1984.01
28.40	62.61	185.63	1998.11
28.60	63.05	186.93	2012.10
28.80	63.49	188.24	2026.20
29.00	63.93	189.55	2040.30
29.20	64.37	190.85	2054.30
29.40	64.81	192.16	2068.40
29.60	65.25	193.47	2082.50
29.80	65.69	194.78	2096.60
30.00	66.13	196.08	2110.59
30.20	66.57	197.39	2124.69
30.40	67.02	198.70	2138.79
30.60	67.46	200.00	2152.79
30.80	67.90	201.31	2166.89
31.00	68.34	202.62	2180.99
31.20	68.78	203.93	2195.09
31.40	69.22	205.23	2209.08

34 MINIMUM FLOOR AREA

Minimum floor area			
m		A _{min}	
kg	lbs	m ²	ft ²
31.60	69.66	206.54	2223.18
31.80	70.10	207.85	2237.28
32.00	70.54	209.16	2251.38
32.20	70.98	210.46	2265.38
32.40	71.42	211.77	2279.48
32.60	71.87	213.08	2293.58
32.80	72.31	214.38	2307.57
33.00	72.75	215.69	2321.67
33.20	73.19	217.00	2335.77
33.40	73.63	218.31	2349.87
33.60	74.07	219.61	2363.87
33.80	74.51	220.92	2377.97
34.00	74.95	222.23	2392.07
34.20	75.39	223.53	2406.06
34.40	75.83	224.84	2420.16
34.60	76.27	226.15	2434.26
34.80	76.72	227.46	2448.36
35.00	77.16	228.76	2462.36
35.20	77.60	230.07	2476.46
35.40	78.04	231.38	2490.56
35.60	78.48	232.68	2504.55
35.80	78.92	233.99	2518.65
36.00	79.36	235.30	2532.75
36.20	79.80	236.61	2546.85
36.40	80.24	237.91	2560.85
36.60	80.68	239.22	2574.95
36.80	81.13	240.53	2589.05
37.00	81.57	241.84	2603.15
37.20	82.01	243.14	2617.14
37.40	82.45	244.45	2631.24
37.60	82.89	245.76	2645.34
37.80	83.33	247.06	2659.34
38.00	83.77	248.37	2673.44
38.20	84.21	249.68	2687.54
38.40	84.65	250.99	2701.64
38.60	85.09	252.29	2715.63
38.80	85.53	253.60	2729.73
39.00	85.98	254.91	2743.83
39.20	86.42	256.21	2757.83
39.40	86.86	257.52	2771.93
39.60	87.30	258.83	2786.03

Minimum floor area			
m		A _{min}	
kg	lbs	m ²	ft ²
39.80	87.74	260.14	2800.13
40.00	88.18	261.44	2814.12
40.20	88.62	262.75	2828.22
40.40	89.06	264.06	2842.32
40.60	89.50	265.36	2856.32
40.80	89.94	266.67	2870.42
41.00	90.38	267.98	2884.52
41.20	90.83	269.29	2898.62
41.40	91.27	270.59	2912.61
41.60	91.71	271.90	2926.71
41.80	92.15	273.21	2940.81
42.00	92.59	274.51	2954.81
42.20	93.03	275.82	2968.91
42.40	93.47	277.13	2983.01
42.60	93.91	278.44	2997.11
42.80	94.35	279.74	3011.10
43.00	94.79	281.05	3025.20
43.20	95.23	282.36	3039.30
43.40	95.68	283.67	3053.40
43.60	96.12	284.97	3067.40
43.80	96.56	286.28	3081.50
44.00	97.00	287.59	3095.60
44.20	97.44	288.89	3109.59
44.40	97.88	290.20	3123.69
44.60	98.32	291.51	3137.79
44.80	98.76	292.82	3151.89
45.00	99.20	294.12	3165.89
45.20	99.64	295.43	3179.99
45.40	100.08	296.74	3194.09
45.60	100.53	298.04	3208.08
45.80	100.97	299.35	3222.18
46.00	101.41	300.66	3236.28
46.20	101.85	301.97	3250.38
46.40	102.29	303.27	3264.38
46.60	102.73	304.58	3278.48
46.80	103.17	305.89	3292.58
47.00	103.61	307.19	3306.57
47.20	104.05	308.50	3320.67
47.40	104.49	309.81	3334.77
47.60	104.94	311.12	3348.87
47.80	105.38	312.42	3362.87

Minimum floor area			
m		A _{min}	
kg	lbs	m ²	ft ²
48.00	105.82	313.73	3376.97
48.20	106.26	315.04	3391.07
48.40	106.70	316.34	3405.06
48.60	107.14	317.65	3419.16
48.80	107.58	318.96	3433.26
49.00	108.02	320.27	3447.36
49.20	108.46	321.57	3461.36
49.40	108.90	322.88	3475.46
49.60	109.34	324.19	3489.56
49.80	109.79	325.50	3503.66
50.00	110.23	326.80	3517.65
50.20	110.67	328.11	3531.75
50.40	111.11	329.42	3545.85
50.60	111.55	330.72	3559.85
50.80	111.99	332.03	3573.95
51.00	112.43	333.34	3588.05
51.20	112.87	334.65	3602.15
51.40	113.31	335.95	3616.14
51.60	113.75	337.26	3630.24
51.80	114.19	338.57	3644.34
52.00	114.64	339.87	3658.34
52.20	115.08	341.18	3672.44
52.40	115.52	342.49	3686.54
52.60	115.96	343.80	3700.64
52.80	116.40	345.10	3714.63
53.00	116.84	346.41	3728.73
53.20	117.28	347.72	3742.83
53.40	117.72	349.02	3756.83
53.60	118.16	350.33	3770.93
53.80	118.60	351.64	3785.03
54.00	119.04	352.95	3799.13
54.20	119.49	354.25	3813.12
54.40	119.93	355.56	3827.22
54.60	120.37	356.87	3841.32
54.80	120.81	358.17	3855.31
55.00	121.25	359.48	3869.42
55.20	121.69	360.79	3883.52
55.40	122.13	362.10	3897.62
55.60	122.57	363.40	3911.61
55.80	123.01	364.71	3925.71

Minimum floor area			
m		A _{min}	
kg	lbs	m ²	ft ²
56.00	123.45	366.02	3939.81
56.20	123.89	367.33	3953.91
56.40	124.34	368.63	3967.91
56.60	124.78	369.94	3982.01
56.80	125.22	371.25	3996.11
57.00	125.66	372.55	4010.10
57.20	126.10	373.86	4024.20
57.40	126.54	375.17	4038.30
57.60	126.98	376.48	4052.40
57.80	127.42	377.78	4066.40
58.00	127.86	379.09	4080.50
58.20	128.30	380.40	4094.60
58.40	128.74	381.70	4108.59
58.60	129.19	383.01	4122.69
58.80	129.63	384.32	4136.79
59.00	130.07	385.63	4150.89
59.20	130.51	386.93	4164.88
59.40	130.95	388.24	4178.99
59.60	131.39	389.55	4193.09
59.80	131.83	390.85	4207.08
60.00	132.27	392.16	4221.18
60.20	132.71	393.47	4235.28
60.40	133.15	394.78	4249.38
60.60	133.60	396.08	4263.37
60.80	134.04	397.39	4277.48
61.00	134.48	398.70	4291.58
61.20	134.92	400.00	4305.57
61.40	135.36	401.31	4319.67
61.60	135.80	402.62	4333.77
61.80	136.24	403.93	4347.87
62.00	136.68	405.23	4361.86
62.20	137.12	406.54	4375.97
62.40	137.56	407.85	4390.07
62.60	138.00	409.16	4404.17
62.80	138.45	410.46	4418.16
63.00	138.89	411.77	4432.26
63.20	139.33	413.08	4446.36
63.40	139.77	414.38	4460.35
63.60	140.21	415.69	4474.45
63.64	140.30	415.95	4477.25

Minimum floor area for ETRS unit (UL 60335-2-40:2022 Edition 4)

The following instructions apply to appliance marked "ETRS" on the nameplate (enhanced tightness refrigerating systems). Height of room where indoor units are installed must be higher than 2.0 m (6.56 ft).

- Use the <Table4> to determine the minimum floor area with m .
- If m is not in table, use the next larger value.
- m : Total refrigerant charge in system
- Total refrigerant charge in system : factory refrigerant charge +additional refrigerant charge.
- A_{min} : minimum floor area.

NOTE

- Height of suction and discharge outlet of horizontal ducted indoor units must be higher than 1.8 m (5.9 ft).

<Table 4> : Table for ETRS Unit.

Maximum of m is 79.56 kg (175.39 lbs)

Minimum floor area			
m		A _{min}	
kg	lbs	m ²	ft ²
≤ 1.836	≤ 4.05	-	-
1.84	4.05	6.02	64.80
2.00	4.40	6.54	70.40
2.20	4.85	7.19	77.40
2.40	5.29	7.85	84.50
2.60	5.73	8.50	91.50
2.80	6.17	9.16	98.60
3.00	6.61	9.81	105.60
3.20	7.05	10.46	112.60
3.40	7.49	11.12	119.70
3.60	7.93	11.77	126.70
3.80	8.37	12.42	133.69
4.00	8.81	13.08	140.80
4.20	9.25	13.73	147.79
4.40	9.70	14.38	154.79
4.60	10.14	15.04	161.89
4.80	10.58	15.69	168.89
5.00	11.02	16.34	175.89
5.20	11.46	17.00	182.99
5.40	11.90	17.65	189.99
5.60	12.34	18.31	197.09
5.80	12.78	18.96	204.09
6.00	13.22	19.61	211.09
6.20	13.66	20.27	218.19
6.40	14.10	20.92	225.19
6.60	14.55	21.57	232.18
6.80	14.99	22.23	239.29
7.00	15.43	22.88	246.28
7.20	15.87	23.53	253.28
7.40	16.31	24.19	260.38
7.60	16.75	24.84	267.38
7.80	17.19	25.50	274.48

Minimum floor area			
m		A _{min}	
kg	lbs	m ²	ft ²
8.00	17.63	26.15	281.48
8.20	18.07	26.80	288.48
8.40	18.51	27.46	295.58
8.60	18.95	28.11	302.58
8.80	19.40	28.76	309.58
9.00	19.84	29.42	316.68
9.20	20.28	30.07	323.68
9.40	20.72	30.72	330.67
9.60	21.16	31.38	337.78
9.80	21.60	32.03	344.77
10.00	22.04	32.68	351.77
10.20	22.48	33.34	358.87
10.40	22.92	33.99	365.87
10.60	23.36	34.65	372.97
10.80	23.80	35.30	379.97
11.00	24.25	35.95	386.97
11.20	24.69	36.61	394.07
11.40	25.13	37.26	401.07
11.60	25.57	37.91	408.06
11.80	26.01	38.57	415.17
12.00	26.45	39.22	422.17
12.20	26.89	39.87	429.16
12.40	27.33	40.53	436.27
12.60	27.77	41.18	443.26
12.80	28.21	41.84	450.37
13.00	28.66	42.49	457.36
13.20	29.10	43.14	464.36
13.40	29.54	43.80	471.46
13.60	29.98	44.45	478.46
13.80	30.42	45.10	485.46
14.00	30.86	45.76	492.56
14.20	31.30	46.41	499.56

Minimum floor area			
m		A _{min}	
kg	lbs	m ²	ft ²
14.40	31.74	47.06	506.55
14.60	32.18	47.72	513.66
14.80	32.62	48.37	520.66
15.00	33.06	49.02	527.65
15.20	33.51	49.68	534.76
15.40	33.95	50.33	541.75
15.60	34.39	50.99	548.86
15.80	34.83	51.64	555.85
16.00	35.27	52.29	562.85
16.20	35.71	52.95	569.95
16.40	36.15	53.60	576.95
16.60	36.59	54.25	583.95
16.80	37.03	54.91	591.05
17.00	37.47	55.56	598.05
17.20	37.91	56.21	605.04
17.40	38.36	56.87	612.15
17.60	38.80	57.52	619.15
17.80	39.24	58.17	626.14
18.00	39.68	58.83	633.25
18.20	40.12	59.48	640.24
18.40	40.56	60.14	647.35
18.60	41.00	60.79	654.34
18.80	41.44	61.44	661.34
19.00	41.88	62.10	668.44
19.20	42.32	62.75	675.44
19.40	42.76	63.40	682.44
19.60	43.21	64.06	689.54
19.80	43.65	64.71	696.54
20.00	44.09	65.36	703.53
20.20	44.53	66.02	710.64
20.40	44.97	66.67	717.63
20.60	45.41	67.33	724.74

ENGLISH

Minimum floor area			
m		A _{min}	
kg	lbs	m ²	ft ²
20.80	45.85	67.98	731.74
21.00	46.29	68.63	738.73
21.20	46.73	69.29	745.84
21.40	47.17	69.94	752.83
21.60	47.61	70.59	759.83
21.80	48.06	71.25	766.93
22.00	48.50	71.90	773.93
22.20	48.94	72.55	780.93
22.40	49.38	73.21	788.03
22.60	49.82	73.86	795.03
22.80	50.26	74.51	802.02
23.00	50.70	75.17	809.13
23.20	51.14	75.82	816.12
23.40	51.58	76.48	823.23
23.60	52.02	77.13	830.23
23.80	52.47	77.78	837.22
24.00	52.91	78.44	844.33
24.20	53.35	79.09	851.32
24.40	53.79	79.74	858.32
24.60	54.23	80.40	865.42
24.80	54.67	81.05	872.42
25.00	55.11	81.70	879.42
25.20	55.55	82.36	886.52
25.40	55.99	83.01	893.52
25.60	56.43	83.67	900.62
25.80	56.87	84.32	907.62
26.00	57.32	84.97	914.61
26.20	57.76	85.63	921.72
26.40	58.20	86.28	928.72
26.60	58.64	86.93	935.71
26.80	59.08	87.59	942.82
27.00	59.52	88.24	949.81
27.20	59.96	88.89	956.81
27.40	60.40	89.55	963.91

Minimum floor area			
m		A _{min}	
kg	lbs	m ²	ft ²
27.60	60.84	90.20	970.91
27.80	61.28	90.85	977.91
28.00	61.72	91.51	985.01
28.20	62.17	92.16	992.01
28.40	62.61	92.82	999.11
28.60	63.05	93.47	1006.11
28.80	63.49	94.12	1013.10
29.00	63.93	94.78	1020.21
29.20	64.37	95.43	1027.20
29.40	64.81	96.08	1034.20
29.60	65.25	96.74	1041.31
29.80	65.69	97.39	1048.30
30.00	66.13	98.04	1055.30
30.20	66.57	98.70	1062.40
30.40	67.02	99.35	1069.40
30.60	67.46	100.00	1076.40
30.80	67.90	100.66	1083.50
31.00	68.34	101.31	1090.50
31.20	68.78	101.97	1097.60
31.40	69.22	102.62	1104.60
31.60	69.66	103.27	1111.59
31.80	70.10	103.93	1118.70
32.00	70.54	104.58	1125.69
32.20	70.98	105.23	1132.69
32.40	71.42	105.89	1139.80
32.60	71.87	106.54	1146.79
32.80	72.31	107.19	1153.79
33.00	72.75	107.85	1160.89
33.20	73.19	108.50	1167.89
33.40	73.63	109.16	1174.99
33.60	74.07	109.81	1181.99
33.80	74.51	110.46	1188.99
34.00	74.95	111.12	1196.09
34.20	75.39	111.77	1203.09

Minimum floor area			
m		A _{min}	
kg	lbs	m ²	ft ²
34.40	75.83	112.42	1210.08
34.60	76.27	113.08	1217.19
34.80	76.72	113.73	1224.18
35.00	77.16	114.38	1231.18
35.20	77.60	115.04	1238.29
35.40	78.04	115.69	1245.28
35.60	78.48	116.34	1252.28
35.80	78.92	117.00	1259.38
36.00	79.36	117.65	1266.38
36.20	79.80	118.31	1273.48
36.40	80.24	118.96	1280.48
36.60	80.68	119.61	1287.48
36.80	81.13	120.27	1294.58
37.00	81.57	120.92	1301.58
37.20	82.01	121.57	1308.57
37.40	82.45	122.23	1315.68
37.60	82.89	122.88	1322.67
37.80	83.33	123.53	1329.67
38.00	83.77	124.19	1336.78
38.20	84.21	124.84	1343.77
38.40	84.65	125.50	1350.88
38.60	85.09	126.15	1357.87
38.80	85.53	126.80	1364.87
39.00	85.98	127.46	1371.97
39.20	86.42	128.11	1378.97
39.40	86.86	128.76	1385.97
39.60	87.30	129.42	1393.07
39.80	87.74	130.07	1400.07
40.00	88.18	130.72	1407.06
40.20	88.62	131.38	1414.17
40.40	89.06	132.03	1421.16
40.60	89.50	132.68	1428.16
40.80	89.94	133.34	1435.26
41.00	90.38	133.99	1442.26

Minimum floor area			
m		A _{min}	
kg	lbs	m ²	ft ²
41.20	90.83	134.65	1449.37
41.40	91.27	135.30	1456.36
41.60	91.71	135.95	1463.36
41.80	92.15	136.61	1470.46
42.00	92.59	137.26	1477.46
42.20	93.03	137.91	1484.46
42.40	93.47	138.57	1491.56
42.60	93.91	139.22	1498.56
42.80	94.35	139.87	1505.55
43.00	94.79	140.53	1512.66
43.20	95.23	141.18	1519.65
43.40	95.68	141.84	1526.76
43.60	96.12	142.49	1533.75
43.80	96.56	143.14	1540.75
44.00	97.00	143.80	1547.86
44.20	97.44	144.45	1554.85
44.40	97.88	145.10	1561.85
44.60	98.32	145.76	1568.95
44.80	98.76	146.41	1575.95
45.00	99.20	147.06	1582.95
45.20	99.64	147.72	1590.05
45.40	100.08	148.37	1597.05
45.60	100.53	149.02	1604.04
45.80	100.97	149.68	1611.15
46.00	101.41	150.33	1618.14
46.20	101.85	150.99	1625.25
46.40	102.29	151.64	1632.24
46.60	102.73	152.29	1639.24
46.80	103.17	152.95	1646.35
47.00	103.61	153.60	1653.34
47.20	104.05	154.25	1660.34
47.40	104.49	154.91	1667.44
47.60	104.94	155.56	1674.44
47.80	105.38	156.21	1681.44

Minimum floor area			
m		A _{min}	
kg	lbs	m ²	ft ²
48.00	105.82	156.87	1688.54
48.20	106.26	157.52	1695.54
48.40	106.70	158.17	1702.53
48.60	107.14	158.83	1709.64
48.80	107.58	159.48	1716.63
49.00	108.02	160.14	1723.74
49.20	108.46	160.79	1730.73
49.40	108.90	161.44	1737.73
49.60	109.34	162.10	1744.83
49.80	109.79	162.75	1751.83
50.00	110.23	163.40	1758.83
50.20	110.67	164.06	1765.93
50.40	111.11	164.71	1772.93
50.60	111.55	165.36	1779.93
50.80	111.99	166.02	1787.03
51.00	112.43	166.67	1794.03
51.20	112.87	167.33	1801.13
51.40	113.31	167.98	1808.13
51.60	113.75	168.63	1815.12
51.80	114.19	169.29	1822.23
52.00	114.64	169.94	1829.22
52.20	115.08	170.59	1836.22
52.40	115.52	171.25	1843.32
52.60	115.96	171.90	1850.32
52.80	116.40	172.55	1857.32
53.00	116.84	173.21	1864.42
53.20	117.28	173.86	1871.42
53.40	117.72	174.51	1878.42
53.60	118.16	175.17	1885.52
53.80	118.60	175.82	1892.52
54.00	119.04	176.48	1899.62
54.20	119.49	177.13	1906.62
54.40	119.93	177.78	1913.61
54.60	120.37	178.44	1920.72

Minimum floor area			
m		A _{min}	
kg	lbs	m ²	ft ²
54.80	120.81	179.09	1927.71
55.00	121.25	179.74	1934.71
55.20	121.69	180.40	1941.81
55.40	122.13	181.05	1948.81
55.60	122.57	181.70	1955.81
55.80	123.01	182.36	1962.91
56.00	123.45	183.01	1969.91
56.20	123.89	183.67	1977.01
56.40	124.34	184.32	1984.01
56.60	124.78	184.97	1991.01
56.80	125.22	185.63	1998.11
57.00	125.66	186.28	2005.11
57.20	126.10	186.93	2012.10
57.40	126.54	187.59	2019.21
57.60	126.98	188.24	2026.20
57.80	127.42	188.89	2033.20
58.00	127.86	189.55	2040.30
58.20	128.30	190.20	2047.30
58.40	128.74	190.85	2054.30
58.60	129.19	191.51	2061.40
58.80	129.63	192.16	2068.40
59.00	130.07	192.82	2075.50
59.20	130.51	193.47	2082.50
59.40	130.95	194.12	2089.50
59.60	131.39	194.78	2096.60
59.80	131.83	195.43	2103.60
60.00	132.27	196.08	2110.59
60.20	132.71	196.74	2117.70
60.40	133.15	197.39	2124.69
60.60	133.60	198.04	2131.69
60.80	134.04	198.70	2138.79
61.00	134.48	199.35	2145.79
61.20	134.92	200.00	2152.79
61.40	135.36	200.66	2159.89

40 MINIMUM FLOOR AREA

Minimum floor area			
m		A _{min}	
kg	lbs	m ²	ft ²
61.60	135.80	201.31	2166.89
61.80	136.24	201.97	2173.99
62.00	136.68	202.62	2180.99
62.20	137.12	203.27	2187.99
62.40	137.56	203.93	2195.09
62.60	138.00	204.58	2202.09
62.80	138.45	205.23	2209.08
63.00	138.89	205.89	2216.19
63.20	139.33	206.54	2223.18
63.40	139.77	207.19	2230.18
63.60	140.21	207.85	2237.28
63.80	140.65	208.50	2244.28
64.00	141.09	209.16	2251.38
64.20	141.53	209.81	2258.38
64.40	141.97	210.46	2265.38
64.60	142.41	211.12	2272.48
64.80	142.85	211.77	2279.48
65.00	143.30	212.42	2286.47
65.20	143.74	213.08	2293.58
65.40	144.18	213.73	2300.58
65.60	144.62	214.38	2307.57
65.80	145.06	215.04	2314.68
66.00	145.50	215.69	2321.67
66.20	145.94	216.34	2328.67
66.40	146.38	217.00	2335.77
66.60	146.82	217.65	2342.77
66.80	147.26	218.31	2349.87
67.00	147.70	218.96	2356.87
67.20	148.15	219.61	2363.87
67.40	148.59	220.27	2370.97
67.60	149.03	220.92	2377.97

Minimum floor area			
m		A _{min}	
kg	lbs	m ²	ft ²
67.80	149.47	221.57	2384.96
68.00	149.91	222.23	2392.07
68.20	150.35	222.88	2399.07
68.40	150.79	223.53	2406.06
68.60	151.23	224.19	2413.17
68.80	151.67	224.84	2420.16
69.00	152.11	225.50	2427.27
69.20	152.55	226.15	2434.26
69.40	153.00	226.80	2441.26
69.60	153.44	227.46	2448.36
69.80	153.88	228.11	2455.36
70.00	154.32	228.76	2462.36
70.20	154.76	229.42	2469.46
70.40	155.20	230.07	2476.46
70.60	155.64	230.72	2483.45
70.80	156.08	231.38	2490.56
71.00	156.52	232.03	2497.56
71.20	156.96	232.68	2504.55
71.40	157.41	233.34	2511.66
71.60	157.85	233.99	2518.65
71.80	158.29	234.65	2525.76
72.00	158.73	235.30	2532.75
72.20	159.17	235.95	2539.75
72.40	159.61	236.61	2546.85
72.60	160.05	237.26	2553.85
72.80	160.49	237.91	2560.85
73.00	160.93	238.57	2567.95
73.20	161.37	239.22	2574.95
73.40	161.81	239.87	2581.94
73.60	162.26	240.53	2589.05
73.80	162.70	241.18	2596.04

Minimum floor area			
m		A _{min}	
kg	lbs	m ²	ft ²
74.00	163.14	241.84	2603.15
74.20	163.58	242.49	2610.15
74.40	164.02	243.14	2617.14
74.60	164.46	243.80	2624.25
74.80	164.90	244.45	2631.24
75.00	165.34	245.10	2638.24
75.20	165.78	245.76	2645.34
75.40	166.22	246.41	2652.34
75.60	166.66	247.06	2659.34
75.80	167.11	247.72	2666.44
76.00	167.55	248.37	2673.44
76.20	167.99	249.02	2680.43
76.40	168.43	249.68	2687.54
76.60	168.87	250.33	2694.53
76.80	169.31	250.99	2701.64
77.00	169.75	251.64	2708.64
77.20	170.19	252.29	2715.63
77.40	170.63	252.95	2722.74
77.60	171.07	253.60	2729.73
77.80	171.51	254.25	2736.73
78.00	171.96	254.91	2743.83
78.20	172.40	255.56	2750.83
78.40	172.84	256.21	2757.83
78.60	173.28	256.87	2764.93
78.80	173.72	257.52	2771.93
79.00	174.16	258.17	2778.92
79.20	174.60	258.83	2786.03
79.40	175.04	259.48	2793.02
79.56	175.39	260.00	2798.62

Minimum total conditioned room area (UL 60335-2-40:2022 Edition 4)

The following instructions apply to ETRS Unit that connected via an air duct system to one or more rooms. If the Leak Detection System is activated, indoor units operate with maximum air flow rate. If maximum air flow rate of ducted indoor unit is more than minimum circulation airflow, minimum floor area can be replaced by minimum total conditioned room area. Height of room where indoor units are installed must be higher than 2.0 m (6.56 ft).

- Maximum air flow rate of ducted indoor unit is announced in EM or E-SVC Manual spec sheet.
- Low static duct shall be connected to one room.
- Use the <Table 5> to determine the minimum total conditioned room area with m.
- If m is not in table, use the next larger value.
- m : Total refrigerant charge in system.
- Total refrigerant charge in system : factory refrigerant charge + additional refrigerant charge.
- Q_{\min} : Minimum circulation air flow.
- TA_{\min} : Minimum total conditioned room area.
- EM : Engineering Manual.
- E-SVC Manual : Service Manual(Exploded View)

42 MINIMUM FLOOR AREA

<Table 5> : Table for ETRS Unit with duct work.

Maximum of m is 44.20 kg (97.44 lbs)

m		Q _{min}		TA _{min}		m		Q _{min}		TA _{min}	
kg	lbs	cmm	cfm	m ²	ft ²	kg	lbs	cmm	cfm	m ²	ft ²
≤ 1.83	≤ 4.04	-	-	-	-	8.80	19.40	14.4	508.6	28.76	309.56
1.84	4.05	3.1	109.5	6.01	64.73	9.00	19.84	14.8	522.7	29.41	316.59
2.00	4.40	3.3	116.6	6.54	70.36	9.20	20.28	15.1	533.3	30.07	323.63
2.20	4.85	3.6	127.2	7.19	77.39	9.40	20.72	15.4	543.9	30.72	330.66
2.40	5.29	4.0	141.3	7.84	84.43	9.60	21.16	15.7	554.5	31.37	337.70
2.60	5.73	4.3	151.9	8.50	91.46	9.80	21.60	16.1	568.6	32.03	344.73
2.80	6.17	4.6	162.5	9.15	98.50	10.00	22.04	16.4	579.2	32.68	351.77
3.00	6.61	5.0	176.6	9.80	105.53	10.20	22.48	16.7	589.8	33.33	358.80
3.20	7.05	5.3	187.2	10.46	112.57	10.40	22.92	17.0	600.4	33.99	365.84
3.40	7.49	5.6	197.8	11.11	119.60	10.60	23.36	17.4	614.5	34.64	372.87
3.60	7.93	5.9	208.4	11.76	126.64	10.80	23.80	17.7	625.1	35.29	379.91
3.80	8.37	6.3	222.5	12.42	133.67	11.00	24.25	18.0	635.7	35.95	386.94
4.00	8.81	6.6	233.1	13.07	140.71	11.20	24.69	18.4	649.8	36.60	393.98
4.20	9.25	6.9	243.7	13.73	147.74	11.40	25.13	18.7	660.4	37.25	401.01
4.40	9.70	7.2	254.3	14.38	154.78	11.60	25.57	19.0	671.0	37.91	408.05
4.60	10.14	7.6	268.4	15.03	161.82	11.80	26.01	19.3	681.6	38.56	415.08
4.80	10.58	7.9	279.0	15.69	168.85	12.00	26.45	19.7	695.7	39.22	422.12
5.00	11.02	8.2	289.6	16.34	175.89	12.20	26.89	20.0	706.3	39.87	429.15
5.20	11.46	8.5	300.2	16.99	182.92	12.40	27.33	20.3	716.9	40.52	436.19
5.40	11.90	8.9	314.4	17.65	189.96	12.60	27.77	20.6	727.5	41.18	443.22
5.60	12.34	9.2	324.9	18.30	196.99	12.80	28.21	21.0	741.7	41.83	450.26
5.80	12.78	9.5	335.5	18.95	204.03	13.00	28.66	21.3	752.3	42.48	457.30
6.00	13.22	9.9	349.7	19.61	211.06	13.20	29.10	21.6	762.8	43.14	464.33
6.20	13.66	10.2	360.3	20.26	218.10	13.40	29.54	21.9	773.4	43.79	471.37
6.40	14.10	10.5	370.9	20.92	225.13	13.60	29.98	22.3	787.6	44.44	478.40
6.60	14.55	10.8	381.4	21.57	232.17	13.80	30.42	22.6	798.2	45.10	485.44
6.80	14.99	11.2	395.6	22.22	239.20	14.00	30.86	22.9	808.8	45.75	492.47
7.00	15.43	11.5	406.2	22.88	246.24	14.20	31.30	23.3	822.9	46.41	499.51
7.20	15.87	11.8	416.8	23.53	253.27	14.40	31.74	23.6	833.5	47.06	506.54
7.40	16.31	12.1	427.4	24.18	260.31	14.60	32.18	23.9	844.1	47.71	513.58
7.60	16.75	12.5	441.5	24.84	267.34	14.80	32.62	24.2	854.7	48.37	520.61
7.80	17.19	12.8	452.1	25.49	274.38	15.00	33.06	24.6	868.8	49.02	527.65
8.00	17.63	13.1	462.7	26.14	281.41	15.20	33.51	24.9	879.4	49.67	534.68
8.20	18.07	13.4	473.3	26.80	288.45	15.40	33.95	25.2	890.0	50.33	541.72
8.40	18.51	13.8	487.4	27.45	295.48	15.60	34.39	25.5	900.6	50.98	548.75
8.60	18.95	14.1	498.0	28.10	302.52	15.80	34.83	25.9	914.7	51.63	555.79

m		Q _{min}		TA _{min}	
kg	lbs	cmm	cfm	m ²	ft ²
16.00	35.27	26.2	925.3	52.29	562.82
16.20	35.71	26.5	935.9	52.94	569.86
16.40	36.15	26.8	946.5	53.59	576.89
16.60	36.59	27.2	960.6	54.25	583.93
16.80	37.03	27.5	971.2	54.90	590.96
17.00	37.47	27.8	981.8	55.56	598.00
17.20	37.91	28.2	995.9	56.21	605.04
17.40	38.36	28.5	1006.5	56.86	612.07
17.60	38.80	28.8	1017.1	57.52	619.11
17.80	39.24	29.1	1027.7	58.17	626.14
18.00	39.68	29.5	1041.8	58.82	633.18
18.20	40.12	29.8	1052.4	59.48	640.21
18.40	40.56	30.1	1063.0	60.13	647.25
18.60	41.00	30.4	1073.6	60.78	654.28
18.80	41.44	30.8	1087.7	61.44	661.32
19.00	41.88	31.1	1098.3	62.09	668.35
19.20	42.32	31.4	1108.9	62.75	675.39
19.40	42.76	31.7	1119.5	63.40	682.42
19.60	43.21	32.1	1133.7	64.05	689.46
19.80	43.65	32.4	1144.2	64.71	696.49
20.00	44.09	32.7	1154.8	65.36	703.53
20.20	44.53	33.1	1169.0	66.01	710.56
20.40	44.97	33.4	1179.6	66.67	717.60
20.60	45.41	33.7	1190.2	67.32	724.63
20.80	45.85	34.0	1200.7	67.97	731.67
21.00	46.29	34.4	1214.9	68.63	738.70
21.20	46.73	34.7	1225.5	69.28	745.74
21.40	47.17	35.0	1236.1	69.93	752.78
21.60	47.61	35.3	1246.7	70.59	759.81
21.80	48.06	35.7	1260.8	71.24	766.85
22.00	48.50	36.0	1271.4	71.90	773.88
22.20	48.94	36.3	1282.0	72.55	780.92
22.40	49.38	36.7	1296.1	73.20	787.95
22.60	49.82	37.0	1306.7	73.86	794.99
22.80	50.26	37.3	1317.3	74.51	802.02
23.00	50.70	37.6	1327.9	75.16	809.06
23.20	51.14	38.0	1342.0	75.82	816.09
23.40	51.58	38.3	1352.6	76.47	823.13
23.60	52.02	38.6	1363.2	77.12	830.16

m		Q _{min}		TA _{min}	
kg	lbs	cmm	cfm	m ²	ft ²
23.80	52.47	38.9	1373.8	77.78	837.20
24.00	52.91	39.3	1387.9	78.43	844.23
24.20	53.35	39.6	1398.5	79.08	851.27
24.40	53.79	39.9	1409.1	79.74	858.30
24.60	54.23	40.2	1419.7	80.39	865.34
24.80	54.67	40.6	1433.8	81.05	872.37
25.00	55.11	40.9	1444.4	81.70	879.41
25.20	55.55	41.2	1455.0	82.35	886.44
25.40	55.99	41.6	1469.1	83.01	893.48
25.60	56.43	41.9	1479.7	83.66	900.52
25.80	56.87	42.2	1490.3	84.31	907.55
26.00	57.32	42.5	1500.9	84.97	914.59
26.20	57.76	42.9	1515.0	85.62	921.62
26.40	58.20	43.2	1525.6	86.27	928.66
26.60	58.64	43.5	1536.2	86.93	935.69
26.80	59.08	43.8	1546.8	87.58	942.73
27.00	59.52	44.2	1561.0	88.24	949.76
27.20	59.96	44.5	1571.6	88.89	956.80
27.40	60.40	44.8	1582.1	89.54	963.83
27.60	60.84	45.1	1592.7	90.20	970.87
27.80	61.28	45.5	1606.9	90.85	977.90
28.00	61.72	45.8	1617.5	91.50	984.94
28.20	62.17	46.1	1628.1	92.16	991.97
28.40	62.61	46.5	1642.2	92.81	999.01
28.60	63.05	46.8	1652.8	93.46	1006.04
28.80	63.49	47.1	1663.4	94.12	1013.08
29.00	63.93	47.4	1674.0	94.77	1020.11
29.20	64.37	47.8	1688.1	95.42	1027.15
29.40	64.81	48.1	1698.7	96.08	1034.18
29.60	65.25	48.4	1709.3	96.73	1041.22
29.80	65.69	48.7	1719.9	97.39	1048.26
30.00	66.13	49.1	1734.0	98.04	1055.29
30.20	66.57	49.4	1744.6	98.69	1062.33
30.40	67.02	49.7	1755.2	99.35	1069.36
30.60	67.46	50.0	1765.8	100.00	1076.40
30.80	67.90	50.4	1779.9	100.65	1083.43
31.00	68.34	50.7	1790.5	101.31	1090.47
31.20	68.78	51.0	1801.1	101.96	1097.50
31.40	69.22	51.4	1815.2	102.61	1104.54

44 MINIMUM FLOOR AREA

m		Q _{min}		TA _{min}	
kg	lbs	cmm	cfm	m ²	ft ²
31.60	69.66	51.7	1825.8	103.27	1111.57
31.80	70.10	52.0	1836.4	103.92	1118.61
32.00	70.54	52.3	1847.0	104.58	1125.64
32.20	70.98	52.7	1861.1	105.23	1132.68
32.40	71.42	53.0	1871.7	105.88	1139.71
32.60	71.87	53.3	1882.3	106.54	1146.75
32.80	72.31	53.6	1892.9	107.19	1153.78
33.00	72.75	54.0	1907.0	107.84	1160.82
33.20	73.19	54.3	1917.6	108.50	1167.85
33.40	73.63	54.6	1928.2	109.15	1174.89
33.60	74.07	55.0	1942.4	109.80	1181.92
33.80	74.51	55.3	1953.0	110.46	1188.96
34.00	74.95	55.6	1963.5	111.11	1196.00
34.20	75.39	55.9	1974.1	111.76	1203.03
34.40	75.83	56.3	1988.3	112.42	1210.07
34.60	76.27	56.6	1998.9	113.07	1217.10
34.80	76.72	56.9	2009.5	113.73	1224.14
35.00	77.16	57.2	2020.0	114.38	1231.17
35.20	77.60	57.6	2034.2	115.03	1238.21
35.40	78.04	57.9	2044.8	115.69	1245.24
35.60	78.48	58.2	2055.4	116.34	1252.28
35.80	78.92	58.5	2066.0	116.99	1259.31
36.00	79.36	58.9	2080.1	117.65	1266.35
36.20	79.80	59.2	2090.7	118.30	1273.38
36.40	80.24	59.5	2101.3	118.95	1280.42
36.60	80.68	59.9	2115.4	119.61	1287.45
36.80	81.13	60.2	2126.0	120.26	1294.49
37.00	81.57	60.5	2136.6	120.92	1301.52
37.20	82.01	60.8	2147.2	121.57	1308.56
37.40	82.45	61.2	2161.3	122.22	1315.59
37.60	82.89	61.5	2171.9	122.88	1322.63
37.80	83.33	61.8	2182.5	123.53	1329.66

m		Q _{min}		TA _{min}	
kg	lbs	cmm	cfm	m ²	ft ²
38.00	83.77	62.1	2193.1	124.18	1336.70
38.20	84.21	62.5	2207.2	124.84	1343.73
38.40	84.65	62.8	2217.8	125.49	1350.77
38.60	85.09	63.1	2228.4	126.14	1357.81
38.80	85.53	63.4	2239.0	126.80	1364.84
39.00	85.98	63.8	2253.1	127.45	1371.88
39.20	86.42	64.1	2263.7	128.10	1378.91
39.40	86.86	64.4	2274.3	128.76	1385.95
39.60	87.30	64.8	2288.4	129.41	1392.98
39.80	87.74	65.1	2299.0	130.07	1400.02
40.00	88.18	65.4	2309.6	130.72	1407.05
40.20	88.62	65.7	2320.2	131.37	1414.09
40.40	89.06	66.1	2334.3	132.03	1421.12
40.60	89.50	66.4	2344.9	132.68	1428.16
40.80	89.94	66.7	2355.5	133.33	1435.19
41.00	90.38	67.0	2366.1	133.99	1442.23
41.20	90.83	67.4	2380.3	134.64	1449.26
41.40	91.27	67.7	2390.9	135.29	1456.30
41.60	91.71	68.0	2401.4	135.95	1463.33
41.80	92.15	68.4	2415.6	136.60	1470.37
42.00	92.59	68.7	2426.2	137.25	1477.40
42.20	93.03	69.0	2436.8	137.91	1484.44
42.40	93.47	69.3	2447.4	138.56	1491.47
42.60	93.91	69.7	2461.5	139.22	1498.51
42.80	94.35	70.0	2472.1	139.87	1505.55
43.00	94.79	70.3	2482.7	140.52	1512.58
43.20	95.23	70.6	2493.3	141.18	1519.62
43.40	95.68	71.0	2507.4	141.83	1526.65
43.60	96.12	71.3	2518.0	142.48	1533.69
43.80	96.56	71.6	2528.6	143.14	1540.72
44.00	97.00	71.9	2539.2	143.79	1547.76
44.20	97.44	72.3	2553.3	144.44	1554.79

Altitude adjustment

- The minimum room area of Amin or TAmin shall be corrected by multiplying by the altitude adjustment factor(AF) in the below table based on for building site ground level altitude (Halt) in meters(feet).

Unit : m (ft)

Halt	0	200 (656.2)	400 (1312.3)	600 (1968.5)	800 (2624.7)	1000 (3280.8)
AF	1	1	1	1	10.2	1.05
Halt	1200 (3937.0)	1400 (4593.2)	1600 (5249.3)	1800 (5905.5)	2000 (6561.7)	
AF	1.07	1.1	1.12	1.15	1.18	

R32 LEAK DETECTION SYSTEM

The R32 refrigerant leak detector detects the concentration of refrigerant (R32) in the air. When the concentration of refrigerant in the air is 5 000 ppm or higher, Leak Detection system will be activated. If Leak Detection system is activated, the following actions will be operated automatically:

- Wired remote controller and indoor units display an Error code and R32 Sensor Sub PCB issues an alarm so that the user realizes that there is a refrigerant leak.(The alarm function is only available in some product)
- The fan of the indoor unit where the error code is displayed will turn on.
- The unit cannot be used until error code disappears.

WARNING

- If there are error code such as 228,229 and 230, ventilate the room and contact authorized personnel immediately.
- If there is an error code of 236, the refrigerant leak detector has a lifetime of less than 6 months. Contact authorized personnel immediately.
- The R32 refrigerant detector must be replaced after detecting any gases or at the end of its lifetime (3650 days).
- Refrigerant leak detectors for Leak Detection System shall only be replaced with detectors specified by the appliance manufacture.
- R32 Leak detection system replacement shall be carried out by authorized personnel only.
- There is possibility detecting other gases, not R32. Do not use highly concentrated chemicals (e.g. Ethanol, Smoke, Hair spray and pesticide) near the indoor unit. R32 refrigerant leakage sensor may detect incorrectly.

1. R32 sensor sub PCB Type

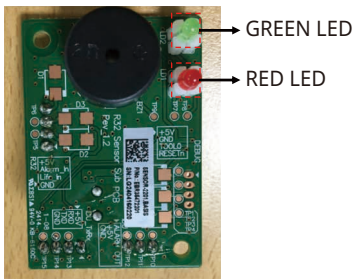

2. Main PCB Type

(R32 Sensor sub PCB is embedded in the Main PCB)

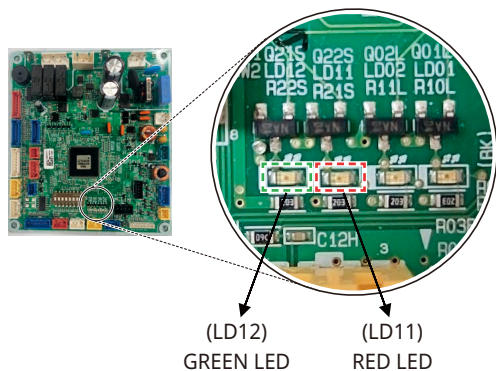

Troubleshooting

Error Code	Error Type	Error point	Main reasons
CH 228	Refrigerant leak detector malfunction error	Refrigerant leak detector has failed.	<ul style="list-style-type: none"> The sensor is breaking of short. Abnormal voltage of DC converter. Abnormal operation of microprocessor.

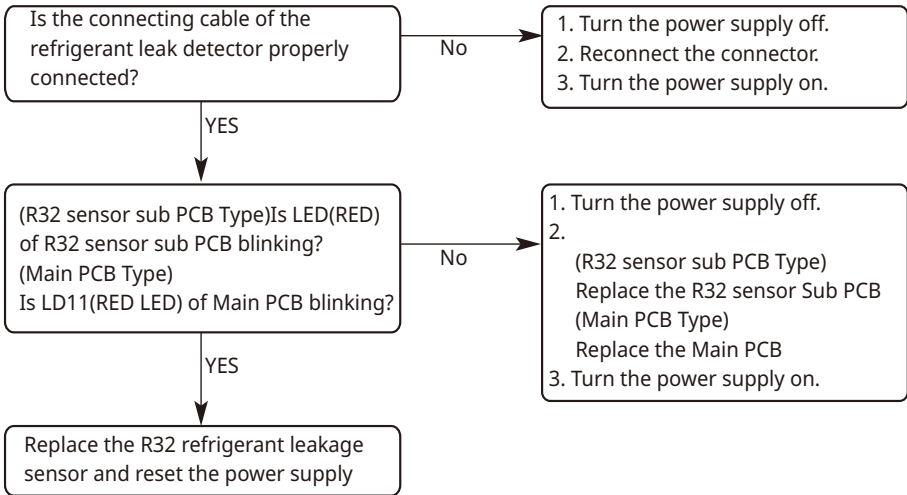

Error Code	Error Type	Error point	Main reasons
CH 229	Refrigerant leak detector lifetime error	The lifetime of the refrigerant leak detector has reached the end	<ul style="list-style-type: none"> The lifetime of the refrigerant leak detector has been reached, so replace the sensor.

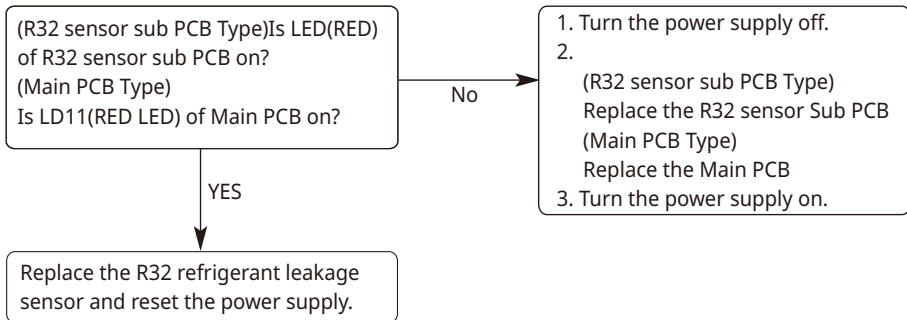

Error Code	Error Type	Error point	Main reasons
CH 230	Refrigerant leak detection error	Refrigerant leak detected by refrigerant leak detector.	<ul style="list-style-type: none"> Refrigerant leak detection

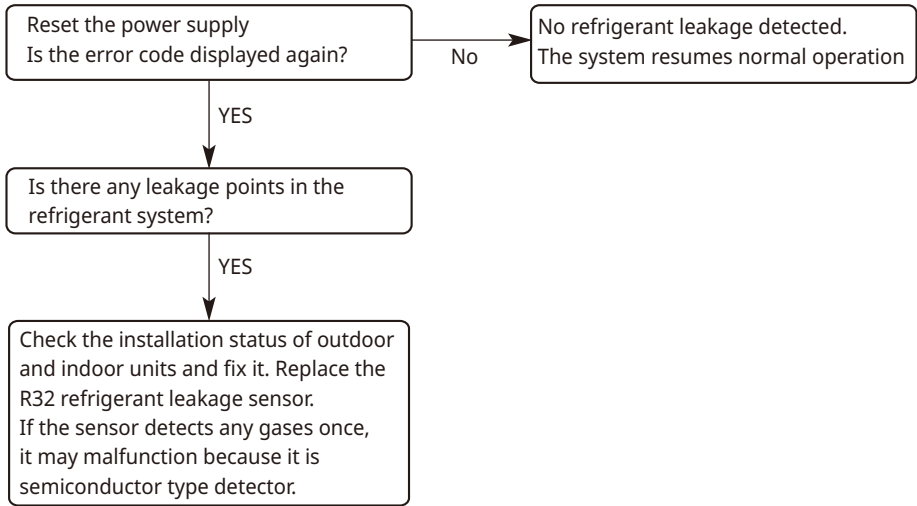

Error Code	Error Type	Error point	Main reasons
CH 236	Refrigerant leak detector lifetime pre-alarm	An error occurs once a month when the lifespan of the leak detector has elapsed 9 years and 6 months. An error occurs once a day when the lifespan of the leak detector has elapsed 9 years and 11 months.	<ul style="list-style-type: none"> The refrigerant leak detector has 10 years lifespan.

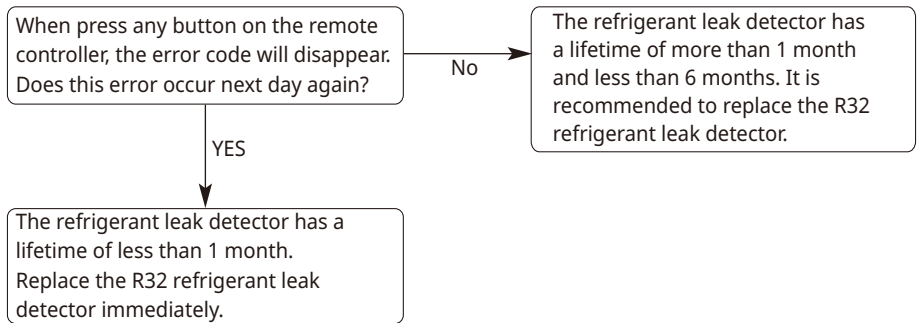

INSTALLATION

Selection of the best location

- Where optimum air distribution can be ensured.
- Where nothing blocks air passage and install the duct work.
- Where condensate can be properly drained.
- Where the ceiling is strong enough to bear the indoor unit weight.
- Where the false ceiling is not noticeably on an incline.
- If top panel access holes for power wiring and communications cable are utilized, the clearance between the unit and the wall could be 0 mm.
- Where piping between indoor and outdoor units is possible within the allowable limit. Refer to the installation manual for the outdoor unit.
- Vertical Air Handling Unit can be installed for upflow, downflow, horizontal-left and right positions.
- Do not install indoor units in laundry rooms.

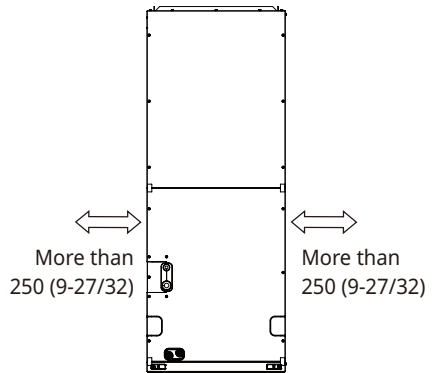
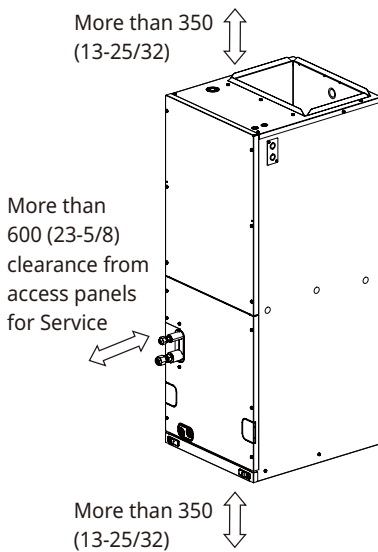

(Unit: mm (inch))

50 INSTALLATION

*Horizontal installation

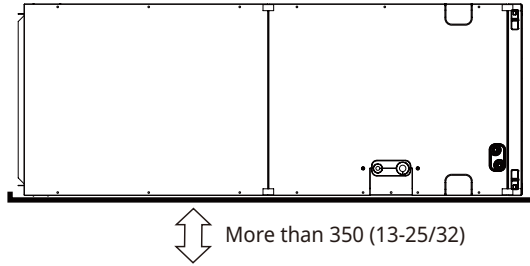

NOTE

- The primary and secondary drain line must be trapped to allow proper drainage of condensate water. If the secondary drain line is not used, it must be capped.

CAUTION

- In the case of sea coast installation, salt residue may cause corrosion of cabinet and component parts. Please take appropriate anti-corrosion measures.

Upflow Installation

- Position unit for plenum installation.
- The plenum should be secured in order to support the installation of adapter callers accommodate the installation of any duct work.
- Seal all duct work according to local codes to prevent air leakage. Ensure that filter access is unobstructed.
- The air handler support platform should be sturdy enough to support the cabinet plus any accessory components including filter box.
- The minimum height clearance is 14 inches (350 mm) to maintain proper air flow.
- Vibration isolators (purchased locally) must be placed between the unit and the pedestal.
- An illustration showing an example of where a vibration isolator should be added would clarify what the installing contractor should do to properly position the isolator.

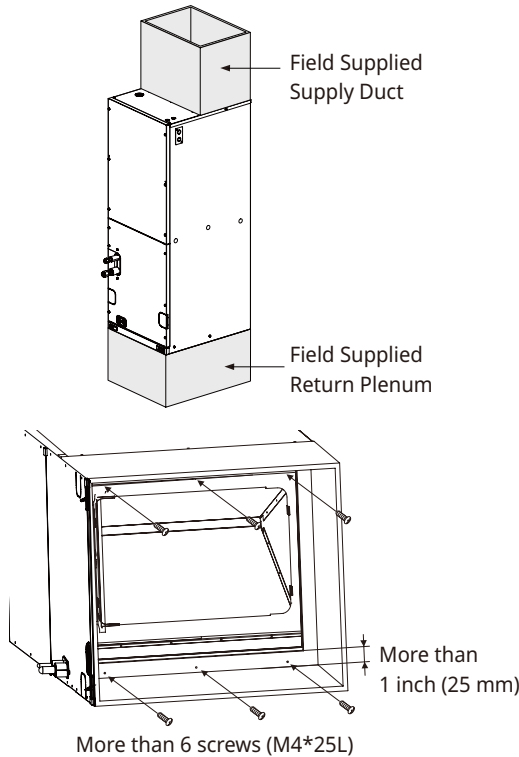

CAUTION

- Do not connect the screws on Front and Rear side, it may cause the filter can not be mounted.

Duct work

- Over 10 screws should be used for joining supply duct with the unit.
- To prevent vibration transmission, exploit flexible connectors between duct and the unit. It is mandatory that the flexible connector between unit and duct at discharge connection should be made of heat resistive material when electric heater is installed.
- Duct work must be insulated and covered with vapor barrier when routed through unconditioned space.
- Internal acoustical insulation lining may necessary for the metal duct system if it do not have 90 ° elbow and 10 ft. of main duct to first branch takeoff.
- It is advised that a fibrous duct work could be used as a substitute if built and installed in accordance with the most recent edition of SMACNA construction standard on fibrous glass ducts.
- Collectively fibrous duct work and acoustical lining shall obey National Fire Protection Association standards 90A or B as tested by UL standard 181 for class 1 air ducts.
- Seal around the delivery duct subsequent to when the duct is secured so that to facilitate prevention of air leakage.

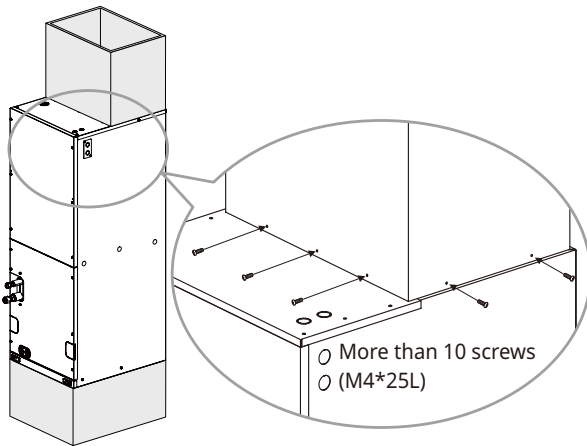

Downflow Installation

Downflow installation requires various changes to the air handling unit from original configuration. There are additional kits required in order to convert the air handling unit to the downflow configuration.

NOTE

- The below specified model should be applied into downflow installation.
 - Model (Downflow installation kit) : PNDFA0
- For detailed information on downflow installation, please refer to the manual included in the downflow installation kit.

Horizontal Installation (Left & Right)

- It is particular that the units should not be installed in such a manner that the access panels facing up or down.
- It should be confirmed that the installation is in accordance with all relevant building codes that may necessitate installation of external condensate pan. (Refer to Figure 2.)
 - Set up a support for unit by locating it in or above external condensate pan.
- Angle steel support brackets with threaded rods which supporting the units from the underside should be used as shown in the Figure 1. below if the units are suspended.
- If not suspended then also it should be supported as same as mentioned above and also carefully isolated to avoid sound transmission. The size of the support should comparatively bigger than the unit and the unit must be place at centre of the support.
- Locally available vibration isolators must be placed between the unit and the support.
- The same installation method of up flow type has to be used in the case of Return Plenum and supply duct.

Figure 1. Suspended Case

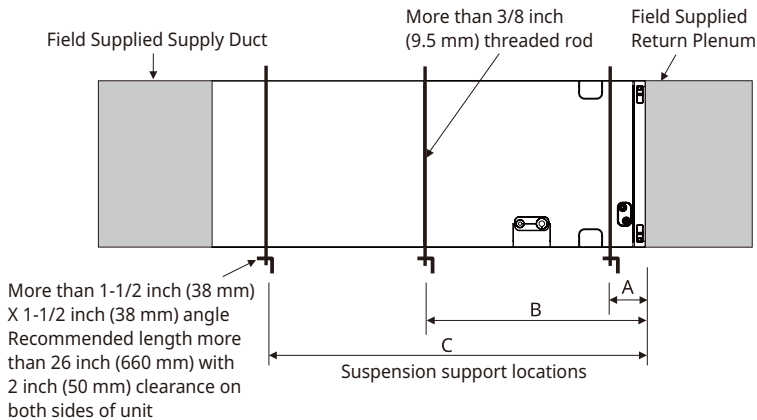

(Unit: inch (mm))

Capacity (kBtu (RT))	Dimension		
	A	B	C
12 (1.0)	4 (100)	23 (580)	41 - 1/2 (1 050)
18 (1.5)			
24 (2.0)			
30 (2.5)	4 (100)	29 (730)	48 (1 220)
36 (3.0)			
42 (3.5)			
48 (4.0)			
60 (5.0)			

When the unit is installed with a horizontal installation scene, hoses included in the assessor bag should be surely installed.

- 1 Remove the hose caps facing toward the drain pan.

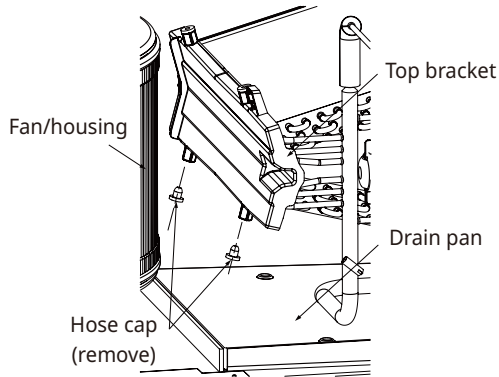

- 2 Install the hoses included in the accessory bag. The rubber hoses should not be restricted to avoid the clogging of the drain rubber tubes. Also, the hoses are recommended to be installed having a arc shape for easy drainage.

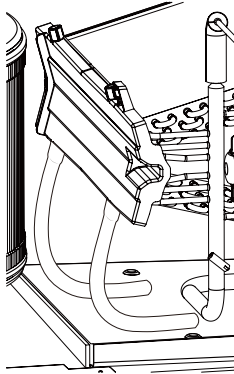
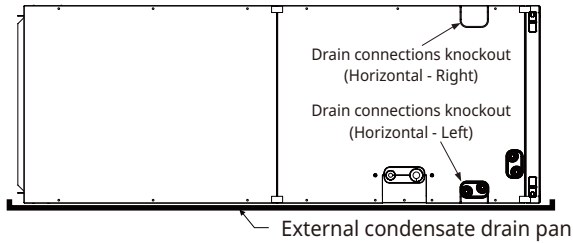

Figure 2. External condensate drain pan

! CAUTION

- For Horizontal installation (left & right), the external condensate drain pan should be installed.
- To ensure proper drainage for horizontal installations, unit must be installed so it is within 1/8" level of the length and width of unit.

Preparation of Piping

Cut the pipes

- 1 Use the pipes purchased locally.
- 2 Measure the distance between the indoor and the outdoor unit.
- 3 Cut the pipes a little longer than measured distance.

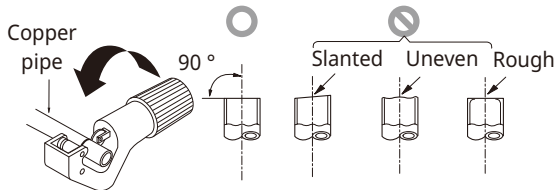

Burrs removal

- 1 Completely remove all burrs from the cut cross section of pipe/tube.
- 2 While removing burrs put the end of the copper tube/pipe in a downward direction while removing burrs location is also changed in order to avoid dropping burrs into the tubing.

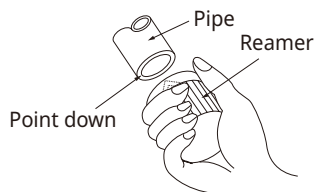

Putting nut on

- 1 Remove flare nuts attached to indoor and outdoor units, than put them on pipe/tube having completed burr removal.
(Not possible to put them on after flaring work)

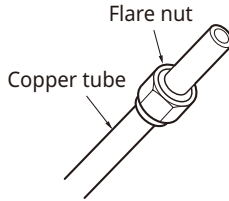

Flaring work

- 1 Carry out flaring work using flaring tool as shown below.

Pipe diameter Inch (mm)	A Inch (mm)		Thickness Inch (mm)
	Wing nut type	Clutch type	
Ø 1/4 (Ø 6.35)	0.04~0.05 (1.1~1.3)	0~0.02 (0~0.5)	0.03 (0.7)
Ø 3/8 (Ø 9.52)	0.06~0.07 (1.5~1.7)		0.03 (0.8)
Ø 1/2 (Ø 12.7)	0.06~0.07 (1.6~1.8)		0.03 (0.8)
Ø 5/8 (Ø 15.88)	0.06~0.07 (1.6~1.8)		0.04 (1.0)
Ø 3/4 (Ø 19.05)	0.07~0.08 (1.9~2.1)		0.04 (1.0)

<Wing nut type>

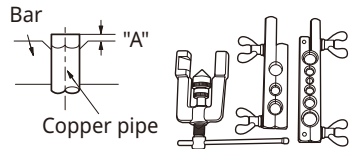

<Clutch type>

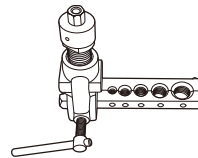

Firmly hold copper tube in a bar(or die) as indicated dimension in the table above.

Check

- 1 Compare the flared work with figure.
- 2 If flare is noted to be defective, cut off the flared section and do flaring work again.

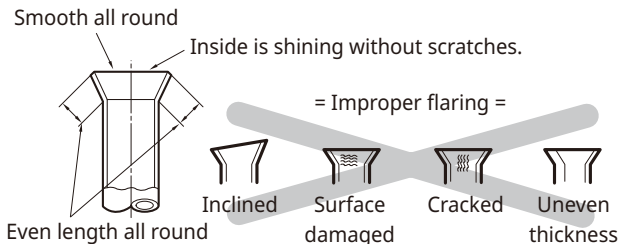

Connection of piping - Indoor, Outdoor, BD Unit

Align the center of the piping and sufficiently tighten the flare nut by hand.

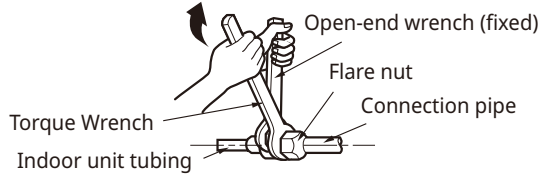
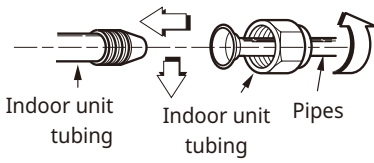

ODU	Indoor Unit Capacity (kBtu/h)	Installed pipe size (inch (mm))	
		Liquid	Gas
Single Zone	12	1/4 (Ø 6.35)	3/8 (Ø 9.52)
	18	3/8 (Ø 9.52)	5/8 (Ø 15.88)
	24		
	30		
	36		
	42		
	48		
	60	3/8 (Ø 9.52)	3/4 (Ø 19.05)
Multi Zone	18	1/4 (Ø 6.35)	1/2 (Ø 12.7)
	24	1/4 (Ø 6.35)	1/2 (Ø 12.7)
	36	3/8 (Ø 9.52)	5/8 (Ø 15.88)

For Multi Zone ODU

For Single Zone ODU

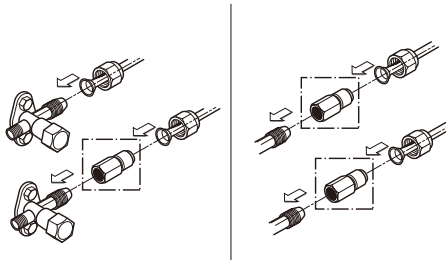

(Only Indoor Units 12 / 18 / 24 kBtu/h)

BD Unit	Connections Size (inch (mm))		Connectable Indoor Unit Capacity (kBtu/h)
	Liquid	Gas	
PMBD3620ZR	1/4 (Ø 6.35) x 2 EA	3/8 (Ø 9.52) x 2 EA	18/24
PMBD3630ZR	1/4 (Ø 6.35) x 3 EA	3/8 (Ø 9.52) x 3 EA	18/24
PMBD3640ZR	1/4 (Ø 6.35) x 4 EA	3/8 (Ø 9.52) x 4 EA	18/24
PMBD3641ZR	1/4 (Ø 6.35) x 4 EA	3/8 (Ø 9.52) x 3 EA	18/24 (A/B/C ROOM)
		1/2 (Ø 12.7) x 1 EA	36 (D ROOM)

- BD Unit(PMBD3641) includes the sockets.
(Ø 12.7 → Ø 15.88 x 1 EA, Ø 6.35 → Ø 9.52 x 1 EA)
- Indoor Unit (18/24 k) includes the sockets.
Ø 6.35(1/4) → Ø 9.52(3/8) x 1 (for Single)
Ø 12.7(1/2) → Ø 15.88(5/8) x 1 (for Single)
Ø 9.52(3/8) → Ø 12.7(1/2) x 1 (for Multi ODU)

(PMBD3620ZR / PMBD3630ZR / PMBD3640ZR)

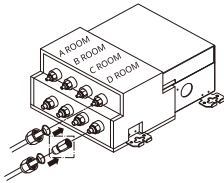

(Only indoor units 18/24 kBtu/h)

(PMBD3641ZR)

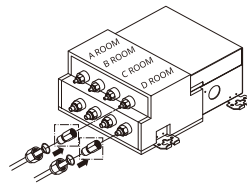

(only indoor units 36 kBtu/h connect "D ROOM")

Finally, tighten the flare nut with torque wrench until the wrench clicks.

- When tightening the flare nut with torque wrench ensure the direction for tightening follows the arrow on the wrench.

Piping Size		Torque		
mm	inch	kgf-cm	N-m	lbf-ft
Ø 6.35	Ø 1/4	180 ~ 250	17.6 ~ 24.5	13 ~ 18
Ø 9.52	Ø 3/8	340 ~ 420	33.3 ~ 41.2	25 ~ 30
Ø 15.88	Ø 5/8	630 ~ 820	61.7 ~ 80.4	45 ~ 59
Ø 12.7	Ø 1/2	550 ~ 660	53.9 ~ 64.7	40 ~ 48
Ø 19.05	Ø 3/4	990 ~ 1 210	97.0 ~ 118.7	71 ~ 87

Connecting Pipes to the Indoor Unit

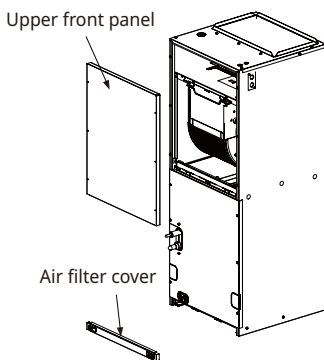

- 1 First detach the upper front panel and then remove the air filter cover from the body.

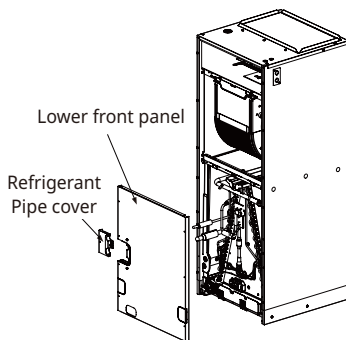

- 2 Detach the lower front panel and refrigerant pipe cover from the body.

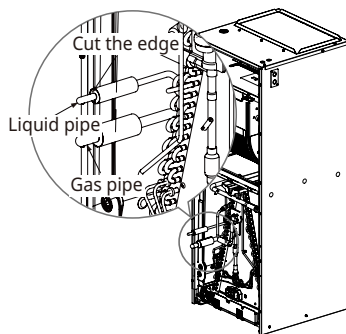

- 3 Cut the refrigerant pipe (Liquid Pipe edge) and make sure the factory charged refrigerant is emerging out. (This confirms there is no leakage.)

4 Cut the end of the liquid and gas pipe

- Gas pipe : 1 kinds of pipe
- Liquid pipe : 1 kinds of pipe

Unit : inch(mm)

	Size	Removing
Gas pipe	3/4 (19.05)	Cutting
Liquid pipe	3/8 (9.52)	

- If you do not use proper cutter size when cutting liquid pipe, it would make damage to the gas pipe.

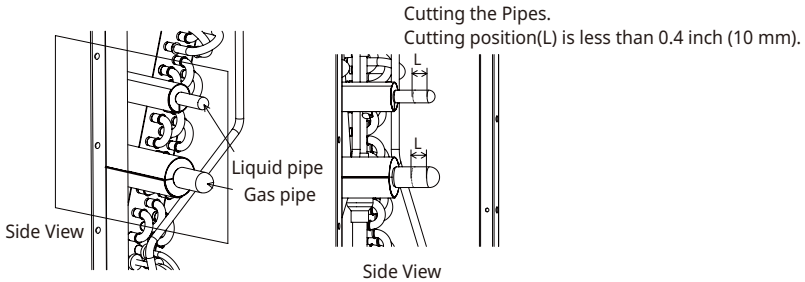

5 Connect the field piping by brazing.

- Wrap the gas and liquid pipe with wet towel. (If not wrapped with a wet towel, there may be damages drain pan or pipe insulations.)

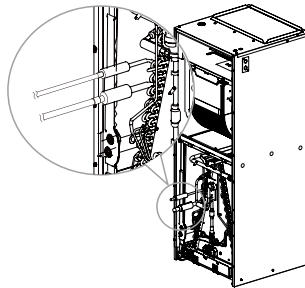

6 Attach the two panels to the body.

- When attaching upper front panel, Insert the bottom side first, then the top side.

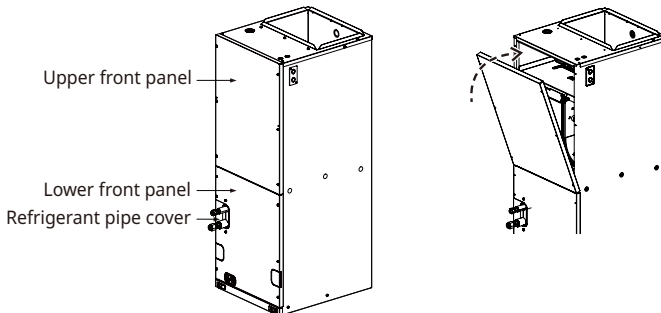

! CAUTION

- Completely remove the refrigerant and then do brazing. Otherwise, high pressure is a risk of injury due to explosions.

NOTE

- Overlap the connection pipe insulation material and the indoor unit pipe insulation material. Bind them together with vinyl tape so that there may be no gap.

! CAUTION

- Always blow nitrogen into pipe which is brazed. Always use a non-oxidizing brazing material for brazing the parts and do not use flux. If not, oxidized film can cause clogging or damage to the compressor unit and flux can harm the copper piping or refrigerant oil.

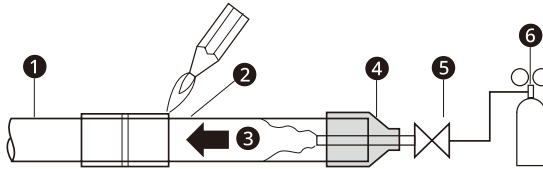

①	Refrigerant piping	④	Taping
②	Pipe to be brazed	⑤	Valve
③	Nitrogen	⑥	Pressure-reducing valve

NOTE

- The torch tip should be positioned at the opposite angle to shop the correct way to apply heat on the pipe coupling.

When mechanical connectors are reused indoors, sealing parts shall be renewed.

When flared joints are reused indoors, the flare part shall be re-fabricated.

A brazed, welded, or mechanical connection shall be made before opening the valves to permit refrigerant to flow between the refrigerating system parts.

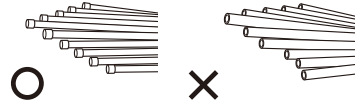

Plumbing materials and storage methods

Pipe must be able to obtain the specified thickness and should be used with low impurities.
 Also when handling storage, pipe must be careful to prevent a fracture, deformity and wound.
 Should not be mixed with contaminations such as dust, moisture.



ENGLISH

Refrigerant piping on three principles

	Drying	Cleanliness	Airtight
	Should be no moisture inside	No dust inside.	There is no refrigerant leakage
Items			
Cause failure	<ul style="list-style-type: none"> • Significant hydrolysis of refrigerant oil • Degradation of refrigerant oil • Poor insulation of the compressor • Do not cold and warm • Clogging of EEV, Capillary 	<ul style="list-style-type: none"> • Degradation of refrigerant oil • Poor insulation of the compressor • Do not cold and warm • Clogging of EEV, Capillary 	<ul style="list-style-type: none"> • Gas shortages • Degradation of refrigerant oil • Poor insulation of the compressor • Do not cold and warm
Countermeasure	<ul style="list-style-type: none"> • No moisture in the pipe • Until the connection is completed, the plumbing pipe entrance should be strictly controlled. • Stop plumbing at rainy day. • Pipe entrance should be taken side or bottom. • When removal burr after cutting pipe, pipe entrance should be taken down. • Pipe entrance should be fitted cap when pass through the walls. 	<ul style="list-style-type: none"> • No dust in the pipe. • Until the connection is completed, the plumbing pipe entrance should be strictly controlled. • Pipe entrance should be taken side or bottom. • When removal burr after cutting pipe, pipe entrance should be taken down. • Pipe entrance should be fitted cap when pass through the walls. 	<ul style="list-style-type: none"> • Airtightness test should be. • Brazing operations to comply with standards. • Flare to comply with standards. • Flange connections to comply with standards.

Nitrogen substitution method

Welding, as when heating without nitrogen substitution a large amount of the oxide film is formed on the internal piping.

The oxide film is caused by clogging EEV, Capillary, oil hole of accumulator and suction hole of oil pump in compressor.

It prevents normal operation of the compressor.

In order to avoid this problem, Welding should be done after replacing air by nitrogen gas.

When welding plumbing pipe, the work is required.

How to work

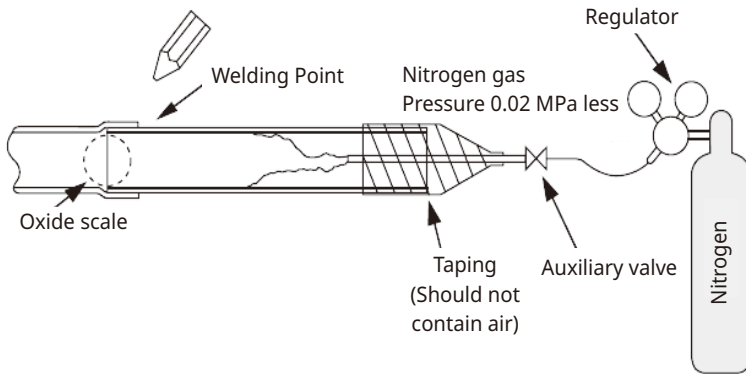

NOTE

- Should not block the outlet side. When the internal pressure in pipe is above the atmospheric pressure, pinhole is occurred and it is a leakage cause.

! CAUTION

- Always use the nitrogen. (not use oxygen, carbon dioxide, and a Chevron gas):
Please use the following nitrogen pressure 0.02 MPa
Oxygen ----- Promotes oxidative degradation of refrigerant oil.
Because it is flammable, it is strictly prohibited to use
Carbon dioxide --- Degrade the drying characteristics of gas
Chevron Gas ---- Toxic gas occurs when exposed to direct flame.
- Always use a pressure reducing valve.
- Please do not use commercially available antioxidant.
The residual material seems to be the oxide scale is observed.
In fact, due to the organic acids generated by oxidation of the alcohol contained in the anti-oxidants, ants nest corrosion occurs. (causes of organic acid → alcohol + copper + water + temperature)

Insulation

Insulate the joint and tubes completely.

Thermal insulation: All thermal insulation must comply with local requirement.

The gas pipe must always be insulated.

DO NOT allow the liquid pipe and gas pipe to come in direct (metal to metal) contact.

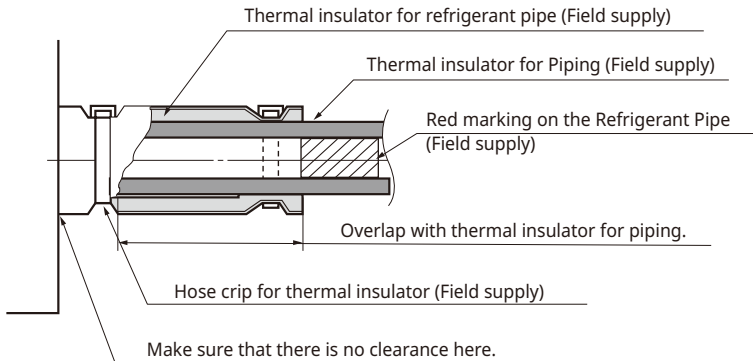
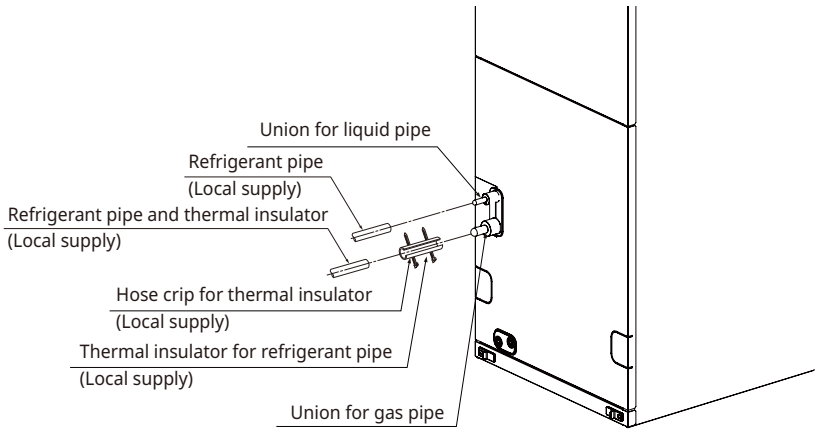

NOTE

- Insulate the liquid pipe if any of the following conditions apply:
 - Cooling Mode: When the liquid line passes through an area where the temperature may reach 30°F (-1°C) or exceed the outdoor ambient temperature.
 - Heating Mode: When the liquid line passes through an area where the indoor temperature may fall below the outdoor ambient temperature.
 - When the outdoor unit is combined with CST, Duct, or Console indoor units.

Recommend

(Unit : inch (mm))

Classification		Air conditioned location		Non-air conditioned location	
		*1) General location	*2) Special location	*3) General location	*4) Negative condition
Liquid Pipe	Ø 1/4 (6.35)	Above t	Above t	Above t	Above t
	Ø 3/8 (9.52)	3/8 (9.52)	3/8 (9.52)	3/8 (9.52)	3/8 (9.52)
	Above Ø 1/2 (12.7)	Above t 1/2 (12.7)	Above t 1/2 (12.7)	Above t 1/2 (12.7)	Above t 1/2 (12.7)
Gas Pipe	Ø 3/8 (9.52)	Above t 1/2 (12.7)	Above t 3/4 (19.05)	Above t 3/4 (19.05)	Above t 1 (25)
	Ø 1/2 (12.7)				
	Ø 5/8 (15.88)				
	Ø 3/4 (19.05)				
	Ø 7/8 (22.22)				
	Ø 1 (25.4)	Above t 3/4 (19.05)	Above t 1 (25)	Above t 1 (25)	
	Ø 1-1/8 (28.58)				
	Ø 1-1/4 (31.75)				
	Ø 1-3/8 (34.9)				
	Ø 1-1/2 (38.1)				
Ø 1-3/4 (44.45)					

*1) General location: When the pipe passes through indoors in which the indoor unit is operated

- Apartment, classroom, office, mall, hospital, office-tel etc.

*2) Special location

- When the location is air conditioned but has severe temperature/humidity difference due to high ceiling
 - Church, auditorium, theater, lobby etc.
- When the location is air conditioned but the internal temperature/humidity of the ceiling finishing is high
 - Bathroom/swimming pool locker room etc. (Building with roof ceiling of sandwich assembly type)

*3) General location: When the pipe passes indoors where the indoor unit is not operated

- Hall way etc. (Dormitory, school, office-tel)

*4) Negative condition: When below conditions 1 and 2 are met.

- When the pipe passes indoors where the indoor unit is not operated
- When the humidity is high, regionally, and there is no air flow in the pipe passing area
 - When installing the outside unit within the outside pipe tray or at a location where it is ok to have freezes, apply 13t.
 - If you are not sure with the selection of heat insulation material, coordinate with the supervision or HQ.
 - The thickness of the above heat insulation material is based on the heat conductivity of 0.088 W/m°C.

Condensate Drain

- The drainage performance has to be optimized by installing both primary and secondary drain lines along with properly sized condensate traps in order to prevent property damage.
- Care should be taken to avoid the blocking of filter access panel while connecting condensate drain lines. The primary and secondary condensate traps has to be primed after connecting to the drain pan.
- A field supplied external condensate pan has to be installed underneath the entire unit if the unit is above the living space. Other wise damage may result due to condensate over flow. Also a additional external condensate line should run from unit in to the pan.
- The entire condensate should be drained from the external condensate pan to some noticeable area. It is advised to install traps in condensate lines as near to the coil as possible. The outlet of each trap should be below its connection to the condensate pan avert condensate from overflowing drain pan.
- If located above the living area then all traps should be prime and insulated and also tested for leakage.
- PVC 3/4 inch (19.05 mm) male pipe thread fitting is advised to use at condensate pan with gentle tight.
- For easy drain flow the drain hose has to be pointed downward.
- Care should be taken to not use pipe joint connection or PVC/CPVC for units drain line connection. Use only Teflon tape.
- For preventing winter freeze up on condensate line special means should be provided for drainage.

GRADIENT OF UNIT AND DRAIN PIPING

- Always lay the drain with downward inclination (1/50 to 1/100). Prevent any upward flow or reverse flow in any part.
- 5/24 inch (5 mm) or thicker formed thermal insulator shall always be provided for the drain pipe.

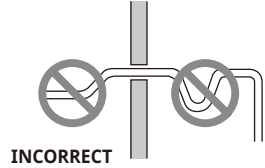
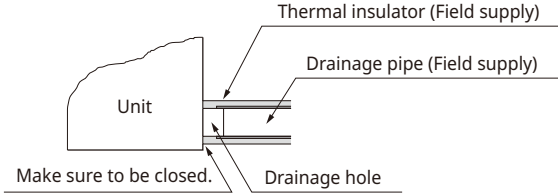

Applied U-Trap Dimension

- A ≥ 2-9/16 inch (70 mm)
- B ≥ 2C
- C ≥ 2 x SP
- SP = External Pressure (in.wc)
- Ex) External Pressure = 0.4 in.wc (10 mmAq)
- A ≥ 2-9/16 inch (70 mm)
- B ≥ 1-7/12 inch (40 mm)
- C ≥ 19/24 inch (20 mm)

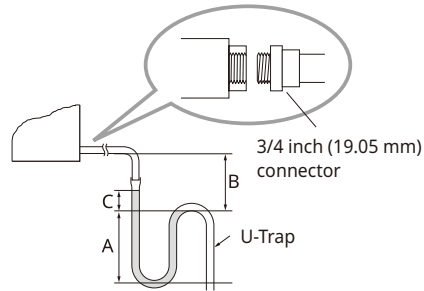

CORRECT

Install the U-Trap to prevent a water leakage caused by the blocking of intake air filter.

Upflow Drain

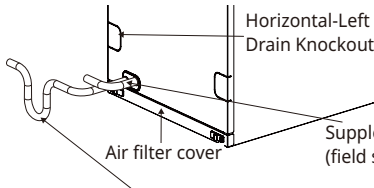

Horizontal-left Drain

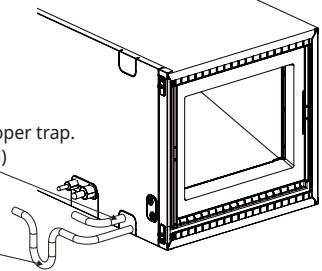

Supplementary drain with proper trap. (field supplied kit can be used)

Main drain along with suitable trap. (Field supplied trap with sufficient depth can be used. P-traps of standard size are not sufficient. Refer the figure for recommended condensate trap.)

! CAUTION

- The supplied flexible drain hose should not be strained.
 - A strained hose may cause leakage of water.

Wiring Connection

Connect the wires to the terminals on the control board individually according to the outdoor unit connection.

Ensure that the color of the wires of outdoor unit and the terminal No. are the same as those of indoor unit respectively.

Pipes and wires should be purchased separately for installation of the product.

When separating indoor unit/outdoor unit power supplies

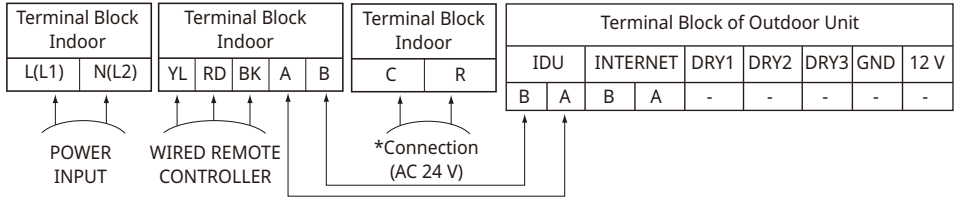

When indoor unit is powered from the out door unit

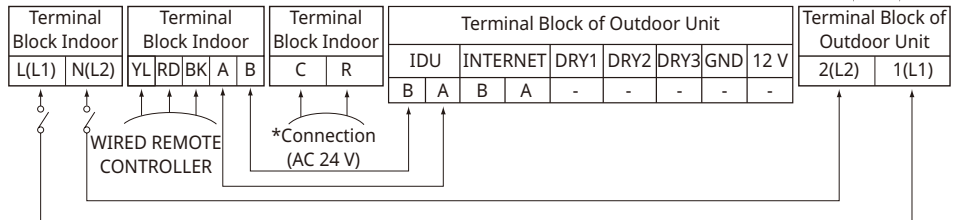

If required by applicable national, state, and local codes, a disconnect switch will need to be installed when the indoor unit is powered from the outdoor unit.

WARNING

- Do NOT connect a power supply to terminal block of AC 24 V (external terminal). If the power supply is connected to the external terminal block, it may cause the damage to the indoor unit.

70 INSTALLATION

(Unit: inch (mm))

	Min wire size (AWG)	Size of conduit (inch (mm))	Knockout diameter (inch (mm))
Power cable	14	1/2 (12.7)	7/8 (22.2)
Communication cable	18	1/2 (12.7)	7/8 (22.2)

- Copper wire should be used.

NOTE

- Use time delay fuses only.
- Check the fuses specification with the circuit label affixed to the control cover.

- 1 Detach the upper panel.
And remove two wiring Knockouts.

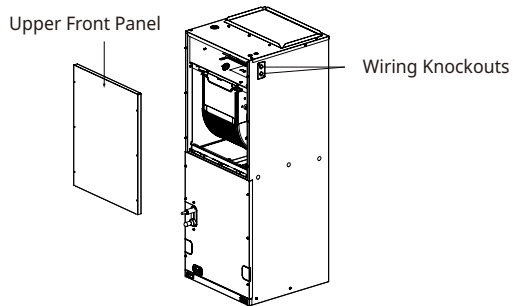

- 2 Install conduit to the wiring knockouts.
Connect power/communication cable to terminal block through the wiring knockouts.

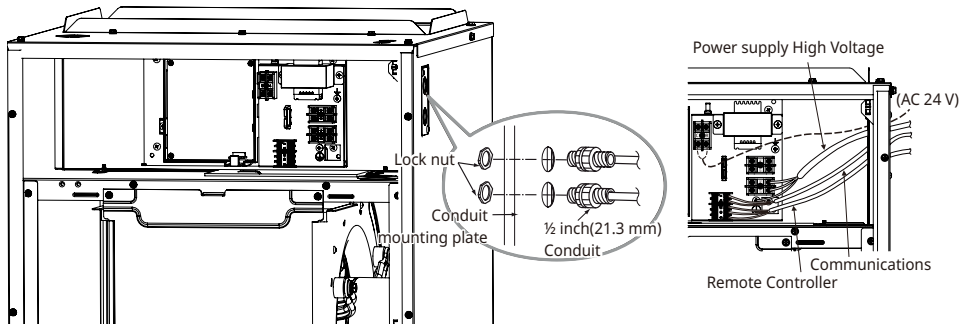

NOTE

- Separately wire power supply cord and connecting cable.
- Use heat-proof electrical wiring capable of withstanding temperature up to 75 °C (167 °F).
- Use outdoor and waterproof connection cable NRTL (UL, ETL, CSA...) listed and rated more than 300 V for the connection between indoor and outdoor unit. and this cable should be enclosed in conduit.
- All communication and power wiring must be connected to the terminals using connectors certified or recognized according to UL and CSA standard.
- When connecting cable, Be sure that there is no break caused by pulling wire.

 **CAUTION**

- After the confirmation of the above conditions, prepare the wiring as follows:
 - Never fail to have individual power specialized for the air conditioner. As for the method of wiring, follow by the circuit diagram posted on the inside of control box cover.
 - Provide a circuit breaker switch between power source and the unit.
 - The screws which fasten the wiring in the casing of electrical fittings are liable to come loose from vibrations to which the unit is subjected during the course of transportation. Check them and make sure that they are all tightly fastened. (If they are loose, it could give rise to burn-out of the wires.)
 - Specification of power source
 - Confirm that electrical capacity is sufficient.
 - Be sure that the starting voltage is within 10 % plus or minus of nameplate voltage rating.
 - Confirm that the cable thickness is as specified in the power sources specification. (Particularly note the relation between cable length and thickness.)
 - Never fail to equip GFCI breaker when installing the air handler near wet or moist locations.
 - The following troubles would be caused by voltage drop-down.
 - a) Vibration of a magnetic switch, damage on the contact point, fuse breaking, disturbance by the normal function of an overload protection device.
 - b) Proper starting power is not given to the compressor.

HAND OVER

Teach the customer the operation and maintenance procedures, using the operation manual. (air filter cleaning, temperature control, etc.)

NOTE

- Openings where field wiring enters the cabinet must be completely sealed.

! CAUTION

- Please refer to the instructions below for proper installation.
 - Power wiring/power wiring gauge to the outdoor unit(s) must be solid or stranded and must comply with all National Electrical Code (NEC), UL, and local electrical codes.
 - Power wiring cable from the outdoor unit to the indoor unit must be a minimum of 14 AWG, 3-conductor, solid core or stranded, rated for 600 V.
 - Communication wiring cable from the outdoor unit to the indoor unit must be minimum 18AWG, 2-conductor, twisted, stranded, and shielded (shield must be grounded to the outdoor unit chassis only).

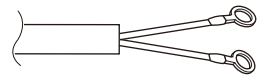
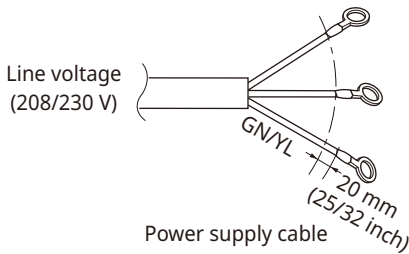

- If the supply cord is damaged, it must be replaced by a special cord or assembly available from the manufacturer of its service agent.

Precautions when laying power and ground wiring

Use round pressure terminals for connections to the power terminal block.

When laying ground wiring, you must use round pressure terminals.

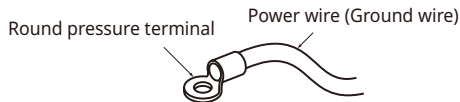

When none are available, follow the instructions below.

- Do not connect wiring of different thicknesses to the power terminal block. (Slack in the power wiring may cause abnormal heat.)
- When connecting wiring which is the same thickness, do as shown in the figure below.

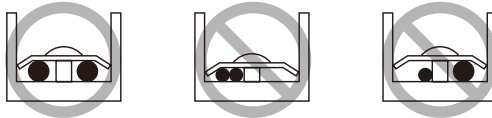

- For wiring, use the designated power wire and connect firmly, then secure to prevent outside pressure being exerted on the terminal block.
- Use an appropriate screwdriver for tightening the terminal screws. A screwdriver with a small head will strip the head and make proper tightening impossible.
- Over-tightening the terminal screws may break them.

Electric Heater

Feature (Example: 15 kW)

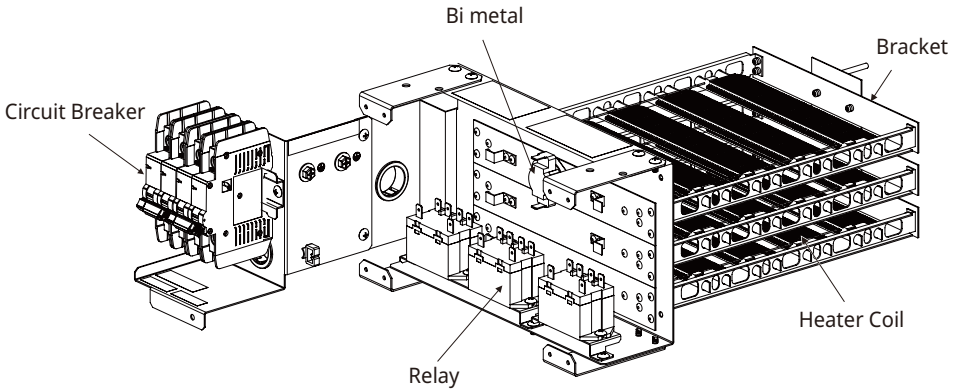

ENGLISH

NOTE

- Image shown above may vary depends on model capacity.

Available heater in model

Capacity (kBtu/h (RT))	Heater Capacity (kW)					
	3	5	8	10	15	20
12 (1.0)	○	○	○	Not available	Not available	Not available
18 (1.5)	○	○	○	○	Not available	Not available
24 (2.0)	○	○	○	○	Not available	Not available
30 (2.5)	○	○	○	○	Not available	Not available
36 (3.0)	○	○	○	○	○	Not available
42 (3.5)	○	○	○	○	○	○
48 (4.0)	○	○	○	○	○	○
60 (5.0)	○	○	○	○	○	○

- If you want to know more optional operation, please refer to the Electric Heater Manual.

Heater Model

- 3 kW: ANEH033C1
- 5 kW: ANEH053C1
- 8 kW: ANEH083C2
- 10 kW: ANEH103C2
- 15 kW: ANEH153C3
- 20 kW: ANEH203C3

Remote controller installation

Remote controller is provided as an accessory.

Please fix tightly using provided screw after placing remote controller setup board on the place where you like to setup.

- Please set it up not to bend because poor setup could take place if setup board bends.
Please set up remote controller board fit to the reclamation box if there is a reclamation box.

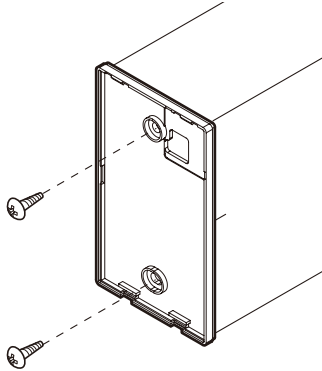

Can set up Wired remote controller cable into three directions.

- Setup direction: the surface of wall reclamation, upper, right
- If setting up remote controller cable into upper and right side, please set up after removing remote controller cable guide groove.
* Remove guide groove with long nose.

- 1 Reclamation to the surface of the wall
- 2 Upper part guide groove
- 3 Right part guide groove

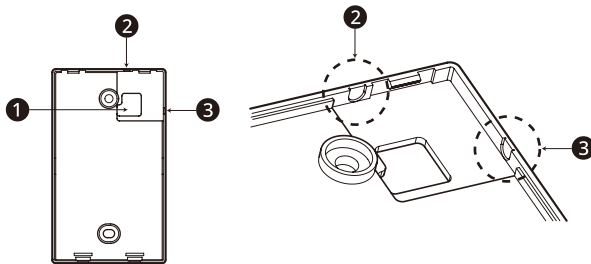

<Wire guide grooves>

Please connect indoor unit and remote controller using connection cable.

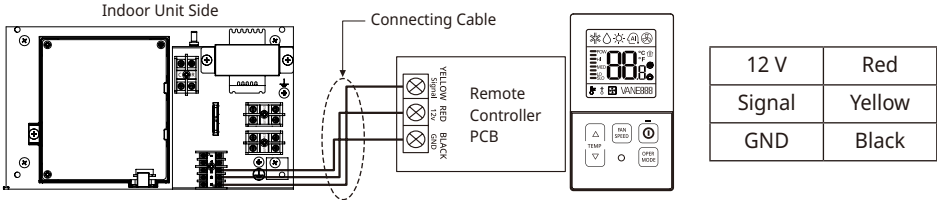

Please use extension cable if the distance between wired remote controller and indoor unit is more than 10 m (32-4/5 ft).

Please fix remote controller upper part into the setup board attached to the surface of the wall, as the picture below, and then, connect with setup board by pressing lower part.

- Please connect not to make a gap at the remote controller and setup board's upper and lower, right and left part.

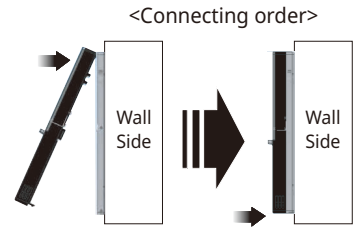

When separating remote controller from setup board, as the picture below, after inserting into the lower separating hole using screw driver and then, spinning clockwise, remote controller is separated.

- There are two separating holes. Please individually separate one at a time.
- Please be careful not to damage the inside components when separating.

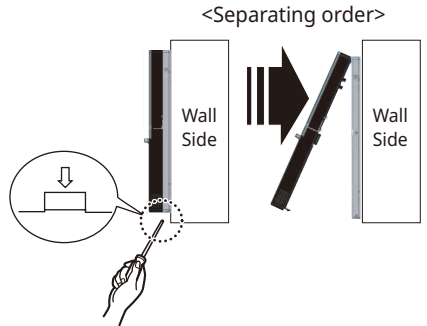

CAUTION

- When installing the wired remote controller, do not bury it in the wall. (It can cause damage in the temperature sensor.)
- Do not install the cable to be 164 ft (50 m) or above. (It can cause communication error.)
 - When installing the extension cable, check the connecting direction of the connector of the remote controller side and the product side for correct installation.
 - If you install the extension cable in the opposite direction, the connector will not be connected.
 - Specification of extension cable: 2547 1007 22# 2 core 3 shield 5 or above.
 - Apply totally enclosed noncombustible conduit in case of local building code Requiring plenum cable usage.

Wired remote controller installation

Since the room temperature sensor is in the remote controller, the remote controller box should be installed in a place away from direct sunlight, high humidity and direct supply of cold air to maintain proper space temperature. Install the remote controller about 5 ft(1.5 m) above the floor in an area with good air circulation at an average temperature.

Do not install the remote controller where it can be affected by:

- Drafts, or dead spots behind doors and in corners.
- Hot or cold air from ducts.
- Radiant heat from sun or appliances.
- Concealed pipes and chimneys.
- Uncontrolled areas such as an outside wall behind the remote controller.
- This remote controller is equipped with LCD. display. For proper display of the remote controller LCD's, the remote controller should be installed properly as shown in Fig.1. (The standard height is 4~5 ft (1.2~1.5 m) from floor level.)

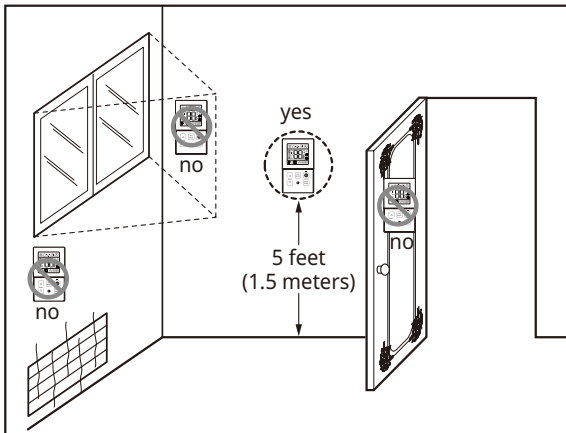

[Fig.1]

CAUTION

- When using the wired remote controller or central controller provided by LG, should disconnect the wire connector between Indoor unit PCB(CN_CC) and dry contact PCB(CN_INDOOR).

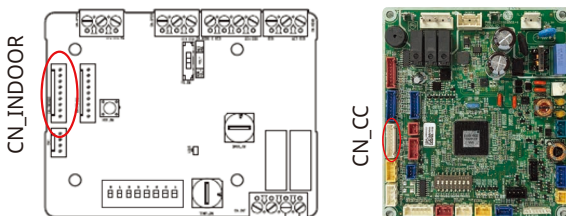

3rd Party Thermostat

When using 3rd party thermostat, should use dry contact together.

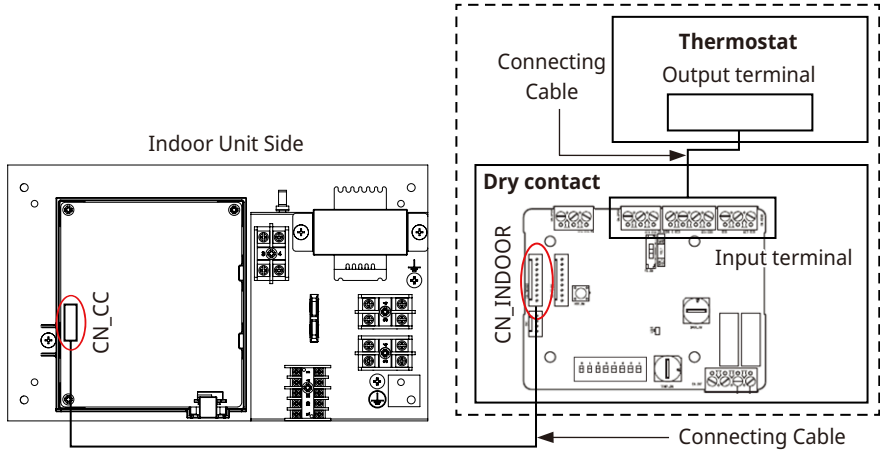

NOTE

- When using the wired remote controller or central controller provided by LG, should disconnect the wire connector between Indoor unit PCB(CN_CC) and dry contact PCB(CN_INDOOR).
- Can not use LG wired remote control and 3rd party thermostat at the same time.
- When connecting the dry contact and thermostat, please refer to dry contact manual and the thermostat manual.

Dip Switch Setting

1. Indoor Unit

	Function	Description	Setting Off	Setting On	Default
SW1	Communication	N/A (Default)	-	-	Off
SW2	Cycle	N/A (Default)	-	-	Off
SW3	Group Control	Selection of Master or Slave	Master	Slave	Off
SW4	Dry Contact Mode	Selection of Dry Contact Mode	Wired/Wireless remote controller selection of Manual or Auto operation Mode	Auto	Off
SW5	Installation	Fan continuous operation	Continuous operation Removal	-	Off
SW6	Heater linkage	N/A	-	-	Off
SW7	Ventilator linkage	Selection of Ventilator linkage	Linkage Removal	Working	Off
	Vane selection (Console)	Selection of up/down side Vane	Up side + Down side Vane	Up side Vane Only	
	Region selection	Selection tropical region	General model	Tropical model	
SW8	Refrigerant Leak Detector	Selection of Installed or Not installed	Not installed	Installed	On

CAUTION

- Indoor unit without Internal Electric Heater
 - DIP switch 1, 2, 6 must be set OFF
- In the case of indoor unit with Internal Electric heater, DIP switch 6 must be set ON.
 - SW6 ON: Automatic Heater operation (Heater operates automatically according to the heater logic without owner's intervene.)
 - SW6 OFF: Heater manual operation (Owner's involvement is required for on/off operation. But the heater operation would be as per the heater logic.)
- In the case of indoor unit with Internal Electric heater, DIP switch 5 on if you want.
 - SW5 ON: Fan operates continuously. (During defrosting or oil return operation, uninterrupted heating can be attained, as a result of continuous heater and fan operation. During defrosting or oil return operation tepid air can come out.
 - SW5 OFF: Fan discontinuous operation (There would be reduction in heating capacity while defrosting or oil return operation.)

Airborne Noise Emission

The A-weighted sound pressure emitted by this product is below 70 dB.

- The noise level can vary depending on the site.



The figures quoted are emission level and are not necessarily safe working levels. Whilst there is a correlation between the emission and exposure levels, this cannot be used reliably to determine whether or not further precautions are required. Factors that influence the actual level of exposure of the workforce include the characteristics of the work room and the other sources of noise, i.e. the number of equipment and other adjacent processes and the length of time for which an operator is exposed to the noise. Also, the permissible exposure level can vary from country to country. This information, however, will enable the user of the equipment to make a better evaluation of the hazard and risk.

PRODUCT DATA

External Static Pressure & Air Flow

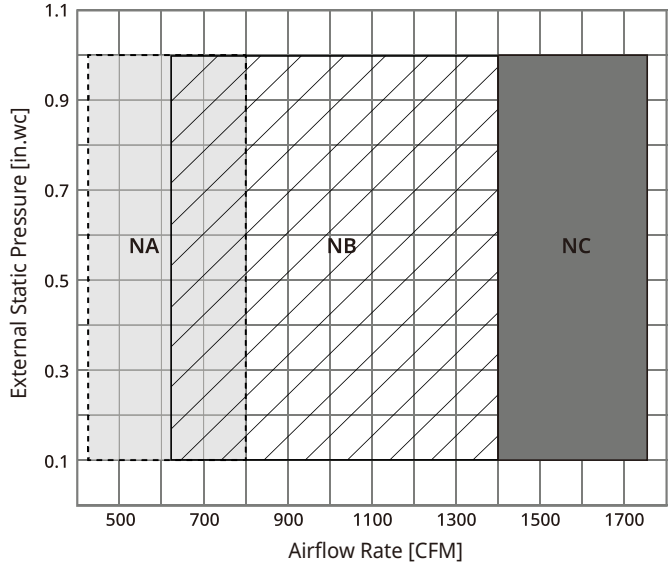
Capacity (kBtu/h (RT))	Step	CFM
12 (1.0)	High	500
	Mid	460
	Low	420
18 (1.5)	High	600
	Mid	510
	Low	440
24 (2.0)	High	800
	Mid	700
	Low	580
30 (2.5)	High	880
	Mid	750
	Low	630
36 (3.0)	High	1 050
	Mid	980
	Low	900
42 (3.5)	High	1 230
	Mid	1 100
	Low	1 000
48 (4.0)	High	1 400
	Mid	1 200
	Low	1 070
60 (5.0)	High	1 750
	Mid	1 580
	Low	1 400



-  : Available Operation Range of NA Chassis(12~24 kBtu/h)
-  : Available Operation Range of NB Chassis(30~48 kBtu/h)
-  : Available Operation Range of NC Chassis(60 kBtu/h)

Air handler units are UL Listed up to 0.5 in.wc external static pressure, including air filter, set coil, and largest kW size heater, unless otherwise noted.

- Some of air handler units (from 1.0 RT to 2.0 RT) have a condition with 400 CFM/ton on each 'High' condition. while other units (from 2.5 RT to 5.0 RT) have 350 CFM/ton on that condition.
- Constant Flow Rate condition is initially operated in the air handler units from 1.0 RT to 5.0 RT.
- in.wc = inch Water Column, inAq

If you set the ESP condition manually, Please refer to External Static Pressure & Air Flow(Manual Setting) section.

This setting must be carried out by a certificated-technician.

External Static Pressure & Air Flow (Manual setting)

Model	Step	CFM	Setting Value @ ESP (in.wc)									
			0.1	0.2	0.3	0.4	0.5	0.6	0.7	0.8	0.9	1.0
KNSLB121A KNMLB121A	HIGH	500	46	52	61	69	76	82	88	93	98	103
	MID	460	40	44	50	57	63	68	73	78	82	86
	LOW	420	40	40	45	49	54	58	62	65	69	72
KNSLB181A KNMLB181A	HIGH	600	50	58	66	73	79	84	89	94	100	105
	MID	510	44	50	56	62	67	72	76	80	84	88
	LOW	440	40	43	46	51	56	60	63	66	70	73
KNSLA181A	HIGH	600	51	59	66	73	78	83	88	93	98	102
	MID	510	43	50	57	64	67	72	76	80	84	88
	LOW	440	40	42	48	56	56	61	63	66	70	73
KNSLB241A KNMLB241A	HIGH	800	57	64	71	77	83	88	93	98	103	107
	MID	700	50	56	61	66	71	75	79	84	88	91
	LOW	580	44	46	50	55	59	62	65	68	71	74
KNSLA241A	HIGH	800	58	65	72	78	83	89	93	98	103	105
	MID	700	51	57	62	69	72	77	81	85	88	91
	LOW	580	42	47	51	56	59	63	66	69	72	74
KNSLB301A KNMLB301A	HIGH	880	56	64	70	77	83	88	93	99	103	109
	MID	750	50	56	62	66	70	77	82	85	90	93
	LOW	630	50	50	52	56	59	64	69	72	75	76
KNSLA301A	HIGH	880	58	65	73	78	83	90	96	101	105	110
	MID	750	51	58	62	66	70	78	83	87	90	93
	LOW	630	50	50	53	56	59	65	70	73	75	77
KNSLB361A KNMLB361A	HIGH	1050	64	71	77	81	87	92	97	102	106	111
	MID	980	55	62	66	70	75	81	84	88	93	97
	LOW	900	50	52	56	60	64	68	71	74	78	81
KNSLA361A	HIGH	1050	63	70	76	82	86	94	98	104	107	112
	MID	980	58	63	70	75	81	84	87	91	95	98
	LOW	900	54	58	66	71	75	77	81	84	78	83

Model	Step	CFM	Setting Value @ ESP (in.wc)									
			0.1	0.2	0.3	0.4	0.5	0.6	0.7	0.8	0.9	1.0
KNSLB421A	HIGH	1230	71	77	83	88	93	98	102	110	111	116
	MID	1100	61	66	71	76	83	84	87	93	95	101
	LOW	1000	56	62	67	72	76	79	82	85	88	91
KNSLB481A	HIGH	1400	79	85	90	94	99	104	105	113	115	120
	MID	1200	67	74	79	81	86	89	93	97	100	105
	LOW	1070	61	65	69	73	77	80	83	86	89	92
KNSLB601A	HIGH	1750	81	86	90	95	100	104	109	112	116	120
	MID	1580	73	76	81	85	89	92	97	100	105	108
	LOW	1400	66	67	73	77	79	82	87	90	95	97

Air handler units are UL Listed up to 0.5 in.wc external static pressure, including air filter, set coil, and largest kW size heater, unless otherwise noted.

- Some of air handler units (from 1.0 RT to 2.0 RT) have a condition with 400 CFM/ton on each 'High' condition. while other units (from 2.5 RT to 5.0 RT) have 350 CFM/ton on that condition.
- in.wc = inch Water Column, inAq

If you set ESP incorrectly, the air conditioner may cause cooling & heating capacity down or malfunction.

This setting must be carried out by a certificated-technician.

NOTE

- The ESP condition of 0.1 in.wc corresponds to 2nd step among 11 step condition. (Likewise, the condition of 1.0 in.wc corresponds to 11 step.)

ELECTRIC HEATER STATIC PRESSURE DROP FACTORS

Heater Capacity (kW)	Static pressure drop (in.wc)
0	0
3, 5	- 0.01
8, 10	- 0.02
15	- 0.03
20	- 0.04

If the electric heater has been installed, then the ESP value has to be adjusted because of the static pressure drop.

- If the product is set to the Constant Flow Rate condition, there is no need to set ESP value.
- If the product is set to the ESP Condition manually, then the ESP value has to be set.

For every increase in static pressure by 0.01 inWC, the ESP value should be increased by 1.

If the setting ESP value is inappropriate, the provided safety device will turn off the heater according to the airflow.

Include -0.04 in wg pressure drop for MPAHU in downflow orientation.

- in.wc = inch Water Column, inAq

Air Filter (Field supply) Static pressure drop factors

Capacity (kBtu/h (RT))	Flow rate (CFM)	Static Pressure drop (in.WC)
12 (1.0)	High (500)	-0.06
	Middle (460)	-0.06
	Low (420)	-0.06
18 (1.5)	High (600)	-0.06
	Middle (510)	-0.06
	Low (440)	-0.06
24 (2.0)	High (800)	-0.06
	Middle (700)	-0.06
	Low (580)	-0.06
30 (2.5)	High (880)	-0.16
	Middle (750)	-0.16
	Low (630)	-0.16
36 (3.0)	High (1 050)	-0.16
	Middle (980)	-0.16
	Low (900)	-0.16
42 (3.5)	High (1 230)	-0.16
	Middle (1 100)	-0.16
	Low (1 000)	-0.16
48 (4.0)	High (1 400)	-0.16
	Middle (1 200)	-0.16
	Low (1 070)	-0.16
60 (5.0)	High (1 750)	-0.16
	Middle (1 580)	-0.16
	Low (1 400)	-0.16

If the air filter has been installed, then the ESP value has to be adjusted because of the static pressure drop.

- If the product is set to the Constant Flow Rate condition, you don't have to set ESP value.
- If the product is set to the ESP Condition manually, then the ESP value has to be set.
- in.wc = inch Water Column, inAq

NOTE

- Filters should be used a rating of MERV 4 or less.
- If you use filters that has a rating MERV 5 or above, it can cause cooling & heating capacity down.
- Include -0.04 in wg pressure drop for MPAHU in downflow orientation.



US	Please call the installing contractor of your product, as warranty service will be provided by them.
CANADA	Service call Number # : (888) LG Canada, (888) 542-2623 Numéro pour les appels de service : LG Canada, 1-888-542-2623