



ENGLISH

ESPAÑOL

PORTUGUÊS

OWNER'S MANUAL

# AIR CONDITIONER

Please read this manual carefully before operating your set and retain it for future reference.



MFL68686424  
Rev.01\_120320

[www.lg.com](http://www.lg.com)

Copyright © 2020 - 2021 LG Electronics Inc. All Rights Reserved.

# TABLE OF CONTENTS

## 3 SAFETY INSTRUCTIONS

---

## 7 PRIOR TO OPERATION

---

- 7 Preparing for operation
- 7 Usage
- 7 Cleaning and maintenance
- 7 Service

## 7 OPERATING INSTRUCTIONS

---

- 7 Auto Restart Function





## 8 MAINTENANCE AND SERVICE

---

- 8 Ceiling Cassette - 4Way
- 11 Ceiling Cassette - Round
- 12 When the air conditioner is not going to be used for a long time.
- 12 Operation Tips
- 13 Before you call for service...

# Safety Instructions

The following symbols are displayed on indoor and outdoor units

	Read the precautions in this manual carefully before operating the unit.		This appliance is filled with flammable refrigerant (for R32)
	This symbol indicates that the Operation Manual should be read carefully.		This symbol indicates that a service personnel should be handling this equipment with reference to the Installation Manual.

The following safety guidelines are intended to prevent unforeseen risks or damage from unsafe or incorrect operation of the appliance.

The guidelines are separated into 'WARNING' and 'CAUTION' as described below.

-  This symbol is displayed to indicate matters and operations that can cause risk. Read the part with this symbol carefully and follow the instructions in order to avoid risk.

## WARNING

This indicates that the failure to follow the instructions can cause serious injury or death.

## CAUTION

This indicates that the failure to follow the instructions can cause the minor injury or damage to the product.

## WARNING

### Installation

- Do not use a defective or underrated circuit breaker. Use this appliance on a dedicated circuit.
  - There is risk of fire or electric shock.
- For electrical work, contact the dealer, seller, a qualified electrician, or an Authorized Service Center.
  - Do not disassemble or repair the product. There is risk of fire or electric shock.
- Always ground the product.
  - There is risk of fire or electric shock.
- Install the panel and the cover of control box securely.
  - There is risk of fire or electric shock.
- Always install a dedicated circuit and breaker.
  - Improper wiring or installation may cause fire or electric shock
- Use the correctly rated breaker or fuse.
  - There is risk of fire or electric shock.
- Do not modify or extend the power cable.
  - There is risk of fire or electric shock.
- Do not install, remove, or re-install the unit by yourself (customer).
  - There is risk of fire, electric shock, explosion, or injury.
- Be cautious when unpacking and installing the product.
  - Sharp edges could cause injury. Be especially careful of the case edges and the fins on the condenser and evaporator.
- For installation, always contact the dealer or an Authorized Service Center.
  - There is risk of fire, electric shock, explosion, or injury.

## Safety Instructions

---

- Do not install the product on a defective installation stand.
  - It may cause injury, accident, or damage to the product.
- Do not turn on the breaker or power under condition that front panel, cabinet, top cover, control box cover are removed or opened.
  - Otherwise, it may cause fire, electric shock, explosion or death.
- Be sure the installation area does not deteriorate with age.
  - If the base collapses, the air conditioner could fall with it, causing property damage, product failure, and personal injury.
- Use a vacuum pump or Inert (nitrogen) gas when doing leakage test or air purge. Do not compress air or Oxygen and Do not use Flammable gases. Otherwise, it may cause fire or explosion.
  - There is the risk of death, injury, fire or explosion.
- The appliance shall be stored in a well-ventilated area where the room size corresponds to the room area as specified for operation. (for R32)
- Ducts connected to an appliance shall not contain an ignition source. (for R32)
- The appliance shall be stored in a room without continuously operating ignition sources (for example: open flames, an operating gas appliance or an operating electric heater.)
- Keep any required ventilation openings clear of obstruction.

### Operation

- Take care to ensure that power cable could not be pulled out or damaged during operation.
  - There is risk of fire or electric shock.
- Do not place anything on the power cable.
  - There is risk of fire or electric shock.
- Do not touch(operate) the product with wet hands.
  - There is risk of fire or electrical shock.
- Do not place a heater or other appliances near the power cable.
  - There is risk of fire and electric shock.
- Do not allow water to run into electric parts.
  - It may cause There is risk of fire, failure of the product, or electric shock.
- Do not store or use flammable gas or combustibles near the product.
  - There is risk of fire or failure of product.
- Do not use the product in a tightly closed space for a long time.
  - Oxygen deficiency could occur.
- When flammable gas leaks, turn off the gas and open a window for ventilation before turn the product on.
  - Do not use the telephone or turn switches on or off. There is risk of explosion or fire.
- If strange sounds, smell or smoke comes from product. Turn the breaker off or disconnect the power supply cable.
  - There is risk of electric shock or fire.
- Stop operation and close the window in storm or hurricane.
  - If possible, remove the product from the window before the hurricane arrives.
  - There is risk of property damage, failure of product, or electric shock.
- Do not open the inlet grill of the product during operation.
  - (Do not touch the electrostatic filter, if the unit is so equipped.)
  - There is risk of physical injury, electric shock, or product failure.
- When the product is soaked (flooded or submerged), contact an Authorized Service Center.
  - There is risk of fire or electric shock.
- Be cautious that water could not enter the product.
  - There is risk of fire, electric shock, or product damage.
- Ventilate the product from time to time when operating it together with a stove, etc.
  - There is risk of fire or electric shock.
- Turn the main power off when cleaning or maintaining the product.
  - There is risk of electric shock.
- Take care to ensure that nobody could step on or fall onto the outdoor unit.
  - This could result in personal injury and product damage.

- Do not let the air conditioner run for a long time when the humidity is very high and a door or a window is left open.
  - Moisture may condense and wet or damage furniture.
- Do not turn on the breaker or power under condition that front panel, cabinet, top cover, control box cover are removed or opened.
  - Otherwise, it may cause fire, electric shock, explosion or death.

## CAUTION

### Installation

- Always check for gas (refrigerant) leakage after installation or repair of product.
  - Low refrigerant levels may cause failure of product.
- Install the drain hose to ensure that water is drained away properly.
  - A bad connection may cause water leakage.
- Keep level even when installing the product.
  - To avoid vibration or water leakage.
- Use two or more people to lift and transport the product.
  - Avoid personal injury.
- Any person who is involved with working on or breaking into a refrigerant circuit should hold a current valid certificate from an industry accredited assessment authority, which authorizes their competence to handle refrigerants safely in accordance with an industry recognized assessment specification. (for R32)
- The appliance shall be stored so as to prevent mechanical damage from occurring.
- Do not install the product where the noise or hot air from the outdoor unit could damage the neighborhoods.
  - It may cause a problem for your neighbors.
- If anyone other than a licensed professional installs, repairs, or alters LG Electronics air conditioning products, the warranty is voided.
  - All costs associated with repair are then the full responsibility of the owner.
- Do not install the unit in potentially explosive atmospheres.

### Operation

- Do not expose the skin directly to cool air for long periods of time. (Don't sit in the draft.)
  - This could harm to your health.
- Do not use the product for special purposes, such as preserving foods, works of art, etc. It is a consumer air conditioner, not a precision refrigeration system.
  - There is risk of damage or loss of property.
- Do not block the inlet or outlet of air flow.
  - It may cause product failure.
- Use a soft cloth to clean. Do not use harsh detergents, solvents, etc.
  - There is risk of fire, electric shock, or damage to the plastic parts of the product.
- Do not touch the metal parts of the product when removing the air filter. They are very sharp!
  - There is risk of personal injury.
- Do not step on or put anything on the product. (outdoor units)
  - There is risk of personal injury and failure of product.
- Always insert the filter securely. Clean the filter every two weeks or more often if necessary.
  - A dirty filter reduces the efficiency of the air conditioner and could cause product malfunction or damage.
- Do not insert hands or other objects through the air inlet or outlet while the product is operated.
  - There are sharp and moving parts that could cause personal injury.
- Do not drink the water drained from the product.
  - It is not sanitary and could cause serious health issues.
- Use a firm stool or ladder when cleaning or maintaining the product.
  - Be careful and avoid personal injury.

## *Safety Precautions*

---

- Servicing shall only be performed as recommended by the equipment manufacturer. Maintenance and repair requiring the assistance of other skilled personnel shall be carried out under the supervision of the person competent in the use of flammable refrigerants. (for R32)
- This appliance is not intended for use by persons (including children) with reduced physical, sensory or mental capabilities or lack of experience and knowledge, unless they have been given supervision or instruction concerning use of the appliance by a person responsible for their safety.
  - Children should be supervised to ensure that they do not play with the appliance.
- This appliance can be used by children aged from 8 years and above and persons with reduced physical, sensory or mental capabilities or lack of experience and knowledge if they have been given supervision or instruction concerning use of the appliance in a safe way and understand the hazards involved. Children shall not play with the appliance. Cleaning and user maintenance shall not be made by children without supervision.
- If the supply cord is damaged, it must be replaced by the manufacturer, its service agent or similarly qualified persons in order to avoid a hazard.
- Do not touch refrigerant pipe and water pipe or any internal parts while the unit is operating or immediately after operation.
  - It can cause a burn or frostbite.
- The user must carry out checks and cleaning of routine to avoid defective performance.
  - In a special situation, only service personnel can carry out repair work.

## Prior to Operation

### *Preparing for operation*

1. Contact an installation specialist for installation.
2. Use a dedicated circuit.

### *Usage*

1. Being exposed to direct airflow for an extended period of time could be hazardous to your health. Do not expose occupants, pets, or plants to direct airflow for extended periods of time.
2. Due to the possibility of oxygen deficiency, ventilate the room when used together with stoves or other heating devices.
3. Do not use this air conditioner for non-specified special purposes (e.g. preserving precision devices, food, pets, plants, and art objects). Such usage could damage the items.

### *Cleaning and maintenance*

1. Do not touch the metal parts of the unit when removing the filter. Injuries can occur when handling sharp metal edges.
2. Do not use water to clean inside the air conditioner. Exposure to water can destroy the insulation, leading to possible electric shock.
3. When cleaning the unit, first make sure that the power and breaker are turned off. The fan rotates at a very high speed during operation. There is a possibility of injury if the unit's power is accidentally triggered on while cleaning inner parts of the unit.

### *Service*

For repair and maintenance, contact your authorized service dealer.

## Operating Instructions

### *Auto Restart Function*

In case the power comes on again after a power failure, Auto Restarting Operation is the function to operate procedures automatically to the previous operating conditions.

# Maintenance and Service

## Ceiling Cassette - 4Way

### ⚠ CAUTION

Before performing any maintenance, turn off the main power to the system.

### Grille, Case, and Remote Control

- ❑ Turn the system off before cleaning. To clean, wipe with a soft, dry cloth. Do not use bleach or abrasives.

**NOTE** Supply power must be disconnected before cleaning the indoor unit.

### Air Filters

The air filters behind the front grille should be checked and cleaned once every 2 weeks or more often if necessary.

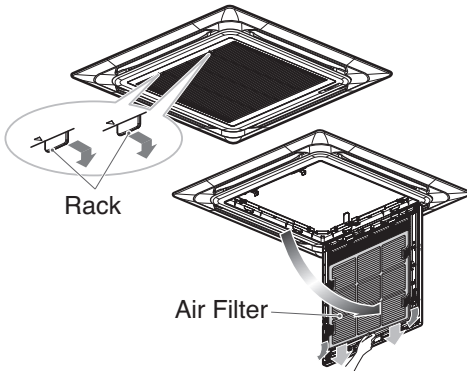

- Never use any of the followings:
  - Water hotter than 40 °C.  
Could cause deformation and/or discoloration.
  - Volatile substances.  
Could damage the surfaces of the air conditioner.

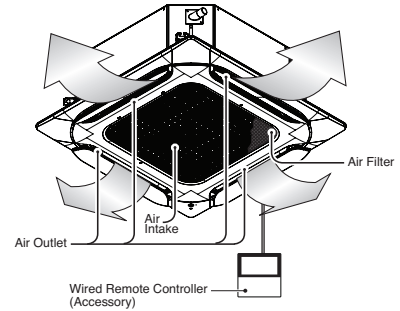
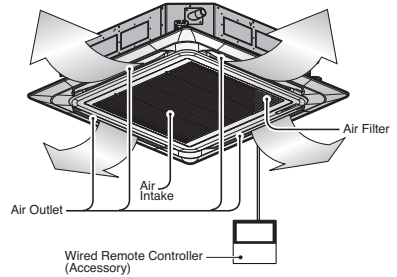

#### 1. Remove the Air filters.

- Take hold of the tab and pull slightly forward to remove the filter.

### ⚠ CAUTION

When the air filter is to be removed, do not touch the metal parts of the indoor unit. It may cause an injury.

#### 2. Clean dirt from the air filter using a vacuum cleaner or washing with water.

- If dirt is conspicuous, wash with a neutral detergent in lukewarm water.
- If hot water (40 °C or more) is used, it may be deformed.

#### 3. After washing with water, dry well in the shade.

- Do not expose the air filter to direct sunlight or heat from a fire when drying it.

#### 4. Install the air filter.

## Cleaning the deodorization filter/PM1.0 filter (Optional)

1. Press the fixing hooks on both sides and open the front grille.

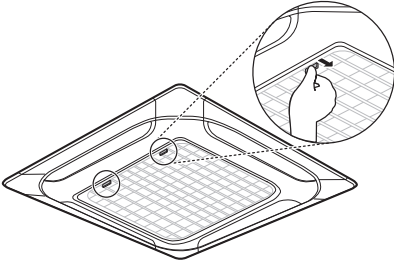

2. Remove PM1.0 filter by pressing the fixing hook.

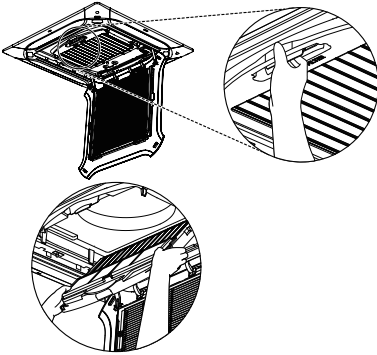

3. Remove the photocatalyst Deodorization filter by pulling upward.

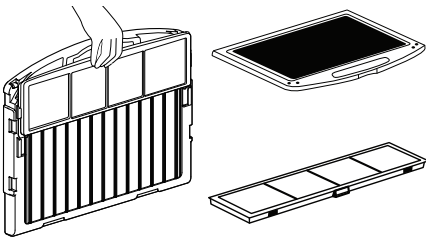

4. After assembling in reverse order, close the front grille.

## ⚠ WARNING

For safety, turn off the main power switch.



## ⚠ CAUTION

- Be careful that the filter case is correctly assembled to the filter holder.
- Be careful not to drop the front grille when removing the filter.
- Do not wash the dust filter with hot water over 40 °C or volatile liquids.
- Do not wash the photocatalytic Deodorization filter in water.
- After cleaning the ultra-fine dust filter, the buzzer sounds 7 times if the water is not completely dry. Dry the filter thoroughly.
- Drying the filter near a fire or in direct sunlight may cause damage to the filter.
- Wear gloves during installation.

### NOTE

- The quantity and type of filters provided by each model may differ.
- The feature may be changed according to the type of model.
- Some functions may not be supported, depending on the model.

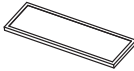
### Filter Information

Filter Name	Filter Description
Deodorization filter 	<ul style="list-style-type: none"> <li>• Dry for 3 hours in sunlight or under fluorescent light.</li> <li>• It is recommended to clean it every six months. (assuming 8 hours of daily use)</li> <li>• Washing the filter with water could damage or deform it.</li> </ul>
PM1.0 filter 	<ul style="list-style-type: none"> <li>• Clean the filter without disassembling it.</li> <li>• Submerge the PM1.0 filter in water, shaking it several times to clean it.</li> <li>• If the filter is very dirty, soak it for 30 minutes in lukewarm water with mild detergent and rinse thoroughly with clean water. (Do not use acidic detergents such as citric acid.)</li> <li>• It is recommended to clean it every six months.</li> <li>• Dry it thoroughly in the shade for about a day. (If there is any remaining moisture, the buzzer will sound 7 times.) Drying with a hot air heater, such as a hair dryer or a heater, could damage or deform the filter.</li> <li>• The inside of the filter is sharp, so do not rub or touch it directly.</li> </ul>

## Cleaning the PM1.0 Sensor

### PM1.0 Sensor

1. Remove the PM1.0 Sensor corner cover on the front panel.

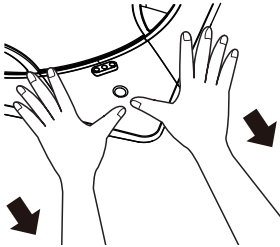

2. Open the PM1.0 sensor case on the side of the PM1.0 Sensor case and remove the rubber cap.

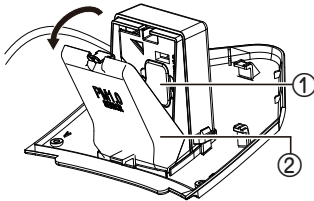

3. Use a cotton swab to wipe the dirt off the lens, and then use a dry swab to remove the moisture.

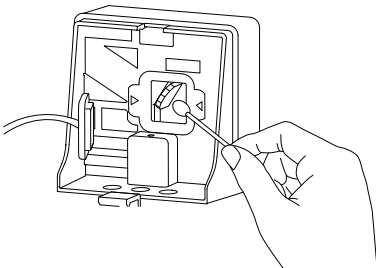

Tighten the rubber cap, close the PM1.0 sensor case, and assemble the PM1.0 Sensor corner cover to its original position.

- ① Rubber cap
- ② PM 1.0 sensor case

## ⚠ WARNING

- For safety, turn off the main power switch.
- Be careful not to drop the product when removing the PM1.0 Sensor corner cover.
- Be careful of falling accidents when cleaning the PM1.0 sensor.

## NOTE

- It is recommended to clean it every six months. (assuming 8 hours of daily use)
- PM1.0 Sensor is only included with Air purification panel.
- The feature may be changed according to the type of model.
- Some functions may not be supported, depending on the model.

## Ceiling Cassette - Round

### ⚠ CAUTION

Before performing any maintenance, turn off the main power to the system.

### Grille, Case, and Remote Control

- ❑ Turn the system off before cleaning. To clean, wipe with a soft, dry cloth. Do not use bleach or abrasives.

#### NOTE

Supply power must be disconnected before cleaning the indoor unit.

### Air Filters

The air filters behind the front grille should be checked and cleaned once every 2 weeks or more often if necessary.

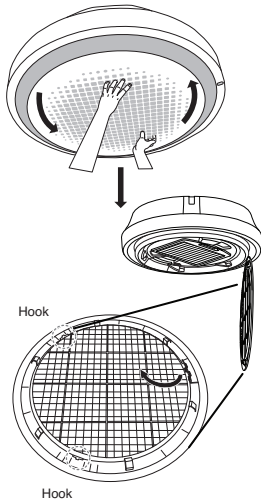

- Never use any of the followings:
  - Water hotter than 40 °C.  
Could cause deformation and/or discoloration.
  - Volatile substances.  
Could damage the surfaces of the air conditioner.

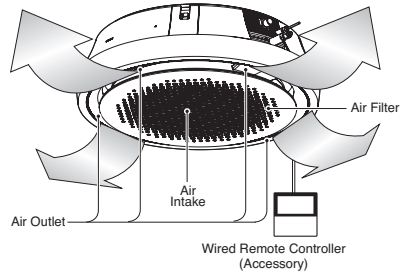

#### 1. Remove the Air filters.

- Take hold of the tab and pull slightly forward to remove the filter.

### ⚠ CAUTION

When the air filter is to be removed, do not touch the metal parts of the indoor unit. It may cause an injury.

#### 2. Clean dirt from the air filter using a vacuum cleaner or washing with water.

- If dirt is conspicuous, wash with a neutral detergent in lukewarm water.
- If hot water (40 °C or more) is used, it may be deformed.

#### 3. After washing with water, dry well in the shade.

- Do not expose the air filter to direct sunlight or heat from a fire when drying it.

#### 4. Install the air filter.

## When the air conditioner is not going to be used for a long time.

When it is not going to be used for a long time.

- 1** Operate the air conditioner at the following settings for 2 to 3 hours.
  - Type of operation: Fan operation mode.
  - This will dry out the internal mechanisms.

- 2** Turn off the breaker.

### **⚠ CAUTION**

Turn off the breaker when the air conditioner is not going to be used for a long time.

Dirt may collect and may cause a fire.

### Helpful information

The air filters and your electric bill.  
If the air filters become clogged with dust, the cooling capacity will drop, and 6% of the electricity used to operate the air conditioner will be wasted.

When the air conditioner is to be used again.

- 1** Clean the air filter and install it in the indoor unit.

- 2** Check that the air inlet and outlet of the indoor/outdoor unit are not blocked.

- 3** Check that the ground wire is connected correctly. It may be connect to the indoor unit side.

## Operation Tips

Do not overcool the room.

This is not good for the health and wastes electricity.

Make sure that the doors and windows are shut tight.

Avoid opening doors and windows as much as possible to keep the cool air in the room.

Keep blinds or curtains closed.

Do not let direct sunshine enter the room when the air conditioner is in operation.

Clean the air filter regularly.

Blockages in the air filter reduce the airflow and lower cooling and dehumidifying effects. Clean at least once every two weeks.

Keep the room temperature uniform.

Adjust the vertical and horizontal airflow direction to ensure a uniform temperature in the room.

Ventilate the room occasionally.

Since windows are kept closed, it is a good idea to open them and ventilate the room now and then.

## Before you call for service...



### Troubleshooting Tips! Save time and money!

Check the following points before requesting repairs or service.... If the malfunction persists, please contact your dealer.

<p><b>The air conditioner does not operate.</b></p> <ul style="list-style-type: none"> <li>• Have you made a mistake in timer operation?</li> <li>• Has the fuse blown or has the circuit breaker been tripped?</li> </ul>	<p><b>The room has a peculiar odor.</b></p> <ul style="list-style-type: none"> <li>• Check that this is not a damp smell exuded by the walls, carpet, furniture or cloth items in the room.</li> </ul>	<p><b>It seems that condensation is leaking from the air conditioner.</b></p> <ul style="list-style-type: none"> <li>• Condensation occurs when the airflow from the air conditioner cools the warm room air.</li> </ul>	<p><b>Air conditioner does not operate for about 3 minutes when restart.</b></p> <ul style="list-style-type: none"> <li>• This is the protector of the mechanism.</li> <li>• Wait about three minutes and operation will begin.</li> </ul>
<p><b>Does not cool or heat effectively.</b></p> <ul style="list-style-type: none"> <li>• Is the air filter dirty? See air filter cleaning instructions.</li> <li>• The room may have been very hot when the room air conditioner was first turned on. Allow time for it to cool down.</li> <li>• Has the temperature been set incorrectly?</li> <li>• Are the indoor unit's air inlet or outlet vents obstructed?</li> </ul>	<p><b>The air conditioner operation is noisy.</b></p> <ul style="list-style-type: none"> <li>• For a noise that sounds like water flowing.           <ul style="list-style-type: none"> <li>-This is the sound of freon flowing inside the air conditioner unit.</li> </ul> </li> <li>• For a noise that sounds like the compressed air releasing into atmosphere.           <ul style="list-style-type: none"> <li>-This is the sound of the dehumidifying water being processed inside the air conditioning unit.</li> </ul> </li> </ul>	<p><b>Crack sound is heard.</b></p> <ul style="list-style-type: none"> <li>• This sound is generated by the expansion/ constriction of the front panel, etc. due to changes of temperature.</li> </ul> <p><b>Remote control display is faint, or no display at all.</b></p> <ul style="list-style-type: none"> <li>• Are the batteries depleted?</li> <li>• Are the batteries inserted in the opposite (+) and (-) directions?</li> </ul>	<p><b>The buzzer sounds. (7 times)</b></p> <ul style="list-style-type: none"> <li>• Is the suction panel completely closed? Close the suction grille completely.</li> <li>• Is the water completely dried after cleaning PM1.0 filter? If moisture remains, let it dry in the shade for about a day.</li> <li>• Is PM1.0 filter film torn? Contact the LG Electronics Service Center.</li> </ul>

#### NOTE

**WATER RESISTANT:** The outdoor side of this appliance is WATER RESISTANT. The indoor side is not water resistant and should not be exposed to excess water. Some functions may not be supported, depending on the model.

**Specifications.**

Model	Max. Current
*RNU05GTR*4	0.2 A
*RNU07GTR*4	0.2 A
*RNU09GTR*4	0.2 A
*RNU09GTRE4	0.2 A
*RNU09GTRF4	0.2 A
*RNU12GTR*4	0.2 A
*RNU15GTR*4	0.2 A
*RNU15GTQ*4	0.2 A
*RNU18GTQ*4	0.2 A
*RNU21GTQ*4	0.2 A
*RNU24GTP*4	0.15 A
*RNU28GTP*4	0.15 A
*RNU30GTP*4	0.15 A
*RNU36GTN*4	0.56 A
*RNU42GTM*4	0.56 A
*RNU48GTM*4	0.56 A
*RNU54GTM*4	0.56 A
*RNU24GTBB4	0.98 A
*RNU28GTBB4	0.98 A
*RNU30GTBB4	0.98 A
*RNU36GTAB4	1.83 A
*RNU42GTAB4	1.83 A
*RNU48GTAB4	1.83 A
*RNU24GTYA4	1.97 A
*RNU36GTYA4	1.97 A
*RNU48GTYA4	1.97 A

\* : A, C

**Frequency / Voltage**

- Argentina : 50 Hz 220-240 V~
- Brazil : 60 Hz 220 V~
- Mexico : 50 Hz 220-240 V~ / 60 Hz 220 V~



Modelo(s): \*RNU05GTR\*4, \*RNU07GTR\*4, \*RNU09GTR\*4, \*RNU09GTRE4  
\*RNU09GTRF4 \*RNU12GTR\*4, \*RNU15GTQ\*4, \*RNU15GTR\*4  
\*RNU18GTQ\*4, \*RNU21GTQ\*4, \*RNU24GTP\*4, \*RNU28GTP\*4  
\*RNU30GTP\*4, \*RNU36GTN\*4, \*RNU42GTM\*4, \*RNU48GTM\*4  
\*RNU54GTM\*4, \*RNU24GTBB4, \*RNU28GTBB4, \*RNU30GTBB4,  
\*RNU36GTAB4, \*RNU42GTAB4, \*RNU48GTAB4, \*RNU24GTYA4,  
\*RNU36GTYA4, \*RNU48GTYA4

\* : A, C

**NOM**

**LG Electronics México, S.A de C.V**

Sor Juana Inés de la Cruz No. 555

Col. San Lorenzo Industrial

Tlalnepantla de Baz Estado de México C.P.  
54033

Tel. 55 5321 1919

Página web <http://www.lg.com/mx>

※ This mark applies to the following products.

※ Esta marca se aplica a los siguientes productos.

ARNU24GTPC4, ARNU28GTPC4, ARNU30GTPC4  
ARNU36GTNC4, ARNU42GTMC4, ARNU48GTMC4  
ARNU54GTMC4, ARNU24GTBB4, ARNU28GTBB4,  
ARNU30GTBB4, ARNU36GTAB4, ARNU42GTAB4,  
ARNU48GTAB4, ARNU24GTYA4, ARNU36GTYA4,  
ARNU48GTYA4