



Scan the QR code to see the manual.



OWNER'S MANUAL

BUILT-IN OVEN



Before beginning installation, read these instructions carefully. This will simplify installation and ensure that the product is installed correctly and safely. Leave these instructions near the product after installation for future reference.

ENGLISH

WSED7667M, WSED7665B

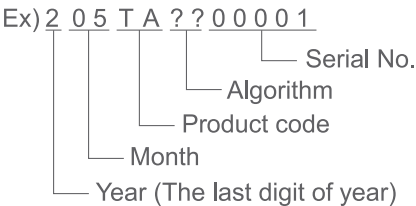

MFL71927517
Rev.03_052926



www.lg.com

TABLE OF CONTENTS

This manual may contain images or content that may be different from the model you purchased.
This manual is subject to revision by the manufacturer.

IMPORTANT SAFETY INSTRUCTIONS

- READ ALL INSTRUCTIONS BEFORE USE 5**
 - Safety Messages.....5
- WARNING 6**
 - Installation6
 - Operation7
 - Maintenance9
 - Risk of Fire and Flammable Materials.....10
- CAUTION..... 11**
 - Operation11
 - Maintenance12
 - Using Steam Function.....12
- CARING FOR THE ENVIRONMENT 13**
 - Disposal13
 - Used Appliances14
- INSTALLATION INSTRUCTIONS..... 14**
 - Safety Instructions for the Installer15
 - Electrical connection.....15

PRODUCT OVERVIEW

- Product Features 17**
 - Exterior / Interior17
 - Accessories.....18

OPERATION

- Operating Control Panel 20**
 - Control Panel Features20
 - Energy Saving Tips22
- Changing Settings 22**
 - Getting Started22
 - Settings.....22
 - Control Lock22
 - Time22

Wi-Fi	23
Remote Start	23
Start Screen	23
Brightness	23
Language	23
Volume	23
InstaView	24
Preheat Light	24
Temperature Adjustment	24
Smart Diagnosis	25
Factory Data Reset	25
Demo Mode	25
Oven Cooling	26
Timer	26
Operating the Oven	26
Before Using the Oven	26
Assembling Rail(Telescopic) Rack	27
Removing Rail Rack	27
Using the Telescopic Runners	27
Manual Cook	30
Hot Air / Economic Hot Air	36
Recommended Economic Hot Air Guide	37
Baking	37
Recommended Baking Guide	38
Roasting	44
Probe Mode (Model WSED7667M)	45
Recommended Probe Guide	47
Grilling	48
Recommended Grilling Guide	49
Air Fry	50
Recommended Air Frying Guide	52
Air Sous-Vide (Model WSED7665B)	55
Recommended Air Sous-Vide Guide	56
Defrosting	56
Steam Function	58
Steam Cook	59
Sous-Vide (Model WSED7667M)	61
Recommended Sous-Vide Guide	63
Recipe Cook	64
My Recipes	80
Information for Test Institutes	82

SMART FUNCTIONS

LG ThinQ Application	85
LG ThinQ Application Features	85
Installing LG ThinQ Application and Connecting an LG Appliance	85
Open Source Software Notice Information	86
Smart Diagnosis Feature	86
Using LG ThinQ to Diagnose Issues	86
Using Audible Diagnosis to Diagnose Issues	86

MAINTENANCE

Cleaning	88
Interior	88
Exterior	88
EasyClean	89
Cleaning the Water Tank	91
Using Descaling Function	91
Using Draining Function	92
Using Evaporation Function	92
Periodic Maintenance	92
Changing the Oven Light	92
Removing, Assembling and Dismantling the Oven Door	93

TROUBLESHOOTING

FAQs	97
Frequently Asked Questions	97
Before Calling for Service	98
Cooking	98
Parts & Features	100
Noises	101
Wi-Fi	101
Customer Service & Spare Parts	101
Standby Power Consumption	102

IMPORTANT SAFETY INSTRUCTIONS

READ ALL INSTRUCTIONS BEFORE USE

Safety Messages

Your safety and the safety of others are very important.

We have provided many important safety messages in this manual and on your appliance. Always read and follow all safety messages.

Read and follow instructions when you use the appliance to avoid fire risks, electric shock, bodily injuries or damage. This guide does not include all possible situations that could happen. Always contact your technical service agent or the manufacturer when any incomprehensible problem appears. These instructions are only valid if the country symbol appears on the appliance. If the symbol does not appear on the appliance, it is necessary to refer to the technical instructions which will provide the necessary instructions concerning modification of the appliance to the conditions for use in the country.



This is the safety alert symbol.

This symbol alerts you to potential hazards that can kill or injure you and others. All safety messages will follow the safety alert symbol and either the word **WARNING** or **CAUTION**.

These words mean:



WARNING

You may be killed or seriously injured if you do not follow instructions.



CAUTION

You may be injured or cause damage to the product if you do not follow instructions.

All safety messages will tell you what the potential hazard is, tell you how to reduce the chance of injury, and tell you what may happen if the instructions are not followed.

WARNING

WARNING

- To reduce the risk of explosion, fire, death, electric shock, injury or scalding to persons when using this product, follow basic precautions, including the following:
-

Installation

- Never allow anyone to climb, sit, stand or hang on the oven door. Injury might result from contact with hot food or the oven itself.
- Do not line the oven walls, racks, bottom, or any other part of the oven with aluminum foil or any other material. Doing so will disrupt heat distribution, produce poor baking results and cause permanent damage to the oven interior (aluminum foil will melt to the interior surface of the oven).
- Do not use aluminum foil or any other material to line the oven bottom. Improper installation of oven liners may result in a risk of electric shock or fire.
- Make sure your appliance is properly installed and grounded by a qualified installer, according to the installation instructions. Any adjustment and service should be performed only by qualified installers or service technicians.
- Be certain that all packing materials are removed from the appliance before operating. Keep plastic, clothes, paper, and other flammable materials away from parts of the appliance that may become hot.
- The electrical power must be shut off while the electrical connections are being made.
- Improper connection of aluminum house wiring to copper leads can result in an electrical hazard or fire. Use only connectors designed for joining copper to aluminum and follow the manufacturer's recommended procedure closely.
- Do not open or close the oven door by foot using excessive force.
- Do not obstruct vent hole with tissue.
- Do not use the oven to dry a live animal.

- Do not place, store, or cook any living animals or organism in the oven.
- Do not use the oven for firing of pottery or curing of painted items.
- The appliance must not be installed behind a decorative door in order to avoid overheating.
- Do not install the appliance on the floor.
- Ensure that the appliance is switched off before replacing the lamp to avoid the possibility of electric shock.

Operation

- Do not use this oven for Commercial applications. This oven is exclusively and intended for Domestic use only.
- **DO NOT TOUCH HEATING ELEMENTS OR INTERIOR SURFACES OF THE OVEN.** Heating elements may be hot even though they are dark in color. Interior surfaces of an oven become hot enough to cause burns. During and after use, do not touch or let clothing or other flammable materials contact heating elements or interior surfaces of the oven until they have had sufficient time to cool. Other surfaces, such as oven vent openings and surfaces near these openings, oven doors, and windows of oven doors, also get hot and may cause burns if not allowed to cool.
- Use care when opening the door. The hot air and steam that escape can cause burns to hands, face and eyes. Let hot air or steam escape from the oven before removing or replacing food in the oven.
- Do not use plastic to cover food. Use foil or oven-safe lids only.
- Never attempt to dry a pet in the oven.
- Never use your appliance for warming or heating the room.
- Always use pot holders or oven mitts when removing food from an oven. Cookware will be hot. Use only dry pot holders. Moist or damp pot holders on hot surfaces may result in burns from steam. Do not let the pot holder touch hot heating elements. Do not use a towel or other bulky cloth to remove food.
- Do not heat unopened food containers. Pressure in the containers may cause them to burst which may result in injury.

8 IMPORTANT SAFETY INSTRUCTIONS

- Do not allow aluminum foil or the temperature probe to contact heating elements.
- Do not touch the oven racks while they are hot.
- If a rack must be moved while the oven is hot, do not let the pot holder contact the hot heating element in the oven.
- Pull the oven rack to the stop-lock position when loading and unloading food from the oven. This helps prevent burns caused by touching hot surfaces of the door and oven walls.
- Do not use the oven if a heating element develops a glowing spot during use or shows other signs of damage. A glowing spot indicates the heating element may fail and present a potential burn, fire, or shock hazard. Turn the oven off immediately and have the heating element replaced by a qualified service technician.
- DO NOT block the oven vent during operation. This can damage the electric parts of the oven. Air must be able to circulate freely. The bottom vent trim should be properly assembled on the front bottom of the oven before installing the oven door.
- Do not put large, heavy items such as whole turkeys on the open oven door.
- Take care when the door is open to avoid injury.
- If the door or door seals are damaged, the oven must not be operated until it has been repaired by a competent qualified person.
- Do not allow children to crawl into the oven.
- Do not put your hand under the controller or between the door and bottom vent trim during operation. The outside of the oven can become very hot to the touch.
- This appliance can be used by children aged from 8 years and above and persons with reduced physical, sensory or mental capabilities or lack of experience and knowledge if they have been given supervision or instruction concerning use of the appliance in a safe way and understand the hazards involved. Children shall not play with the appliance. Cleaning and user maintenance shall not be made by children without supervision.

- Young children should be supervised to ensure that they do not play with the appliance.
- During use, the appliance becomes hot. Care should be taken to avoid touching heating elements inside the oven. Young children should be kept away.
 - These surfaces may be hot enough to burn skin even after cooking is finished, though they may not appear to be so, avoid placing hands and arms inside the oven.
- Accessible parts can become hot during use. Young children should be kept away.
- Exposed parts of the oven can become hot during grilling. Keep children at a distance.
- The instructions shall state that under such conditions the surfaces can get hotter than usual and children should be kept away.

Maintenance

- Do not store items of interest to children on the back guard or in cabinets above a cooking appliance. Children climbing on the oven to reach items could be seriously injured.
- Let hot cookware and utensils cool in a safe place, out of reach of small children.
- If the door glass, surface, or oven heating unit of the appliance are damaged, discontinue use of the appliance and call for service.
- Always disconnect power from the appliance before servicing.
- Before replacing the oven light, switch off the electrical power to the oven at the main fuse or circuit breaker panel.
- Never pour cold water over a hot oven for cleaning purposes.
- Do not clean with metal scouring pads. Pieces can burn off the pad and touch electrical parts causing a risk of electric shock.
- Do not store any materials, other than manufacturer's recommended accessories, in this oven when not in use.
- Do not cover racks or any other part of the oven with metal foil. This will cause overheating of the oven.

- If your oven is dropped or damaged, have it thoroughly checked by a qualified service technician before using it.
- If the supply cord is damaged, it must be replaced by the manufacturer, its service agent or similarly qualified persons in order to avoid a hazard. (on some models only)
- **DO NOT TOUCH HEATING ELEMENTS OR INTERIOR SURFACES OF OVEN CAVITY.** During and after use or cleaning the interior, do not touch other flammable materials contact heating elements or interior surfaces of oven cavity until they have had sufficient time to cool. Other surfaces, such as windows of oven door, oven lamp, also get hot and may cause burns if not allowed to cool.
- Do not use harsh abrasive cleaners or sharp metal scrapers to clean the oven door glass/ the glass of hinged lids of the hob (as appropriate), since they can scratch the surface, which can result in shattering of the glass.
- The oven must be switched off before removing the guard and that, after cleaning, the guard must be reinstalled in accordance with the instructions.

Risk of Fire and Flammable Materials

- Do not store or use flammable material in or near the oven. Flammable materials include paper, plastic, pot holders, linens, wall coverings, curtains, and gasoline or other flammable vapors and liquids such as grease or cooking oil. These materials can ignite when the oven is in use.
- Use extreme caution when moving or disposing of hot grease.
- Wear proper apparel. Do not wear loose-fitting or hanging garments, which may ignite if they contact hot surfaces, and cause severe burns.
- Do not use the oven for drying clothes. Only use the oven for its intended purpose.
- If cabinet storage is provided directly above the oven, use it to store items that are not frequently used and can be safely stored in an area subjected to heat. Temperatures may be unsafe for volatile items such as flammable liquids, cleaners or aerosol sprays.

- Do not use water on grease fires. Should an oven fire occur, leave the oven door closed and turn the oven off. If the fire continues, throw baking soda on the fire or use a fire extinguisher. Do not put water or flour on the fire. Flour may be explosive and water can spread a grease fire and cause personal injury.

CAUTION

Operation

- Always heat fat slowly, and watch as it heats.
- If frying combinations of oils and fats, stir them together before heating.
- Use a deep fat thermometer, if possible, to prevent overheating fat beyond the smoking point.
- Use the least possible amount of fat for effective shallow or deep-fat frying. Filling the pan with too much fat can cause spillovers when food is added.
- Accessible parts can become hot when the grill is in use.
- When using cooking or roasting bags in the oven, follow the manufacturer's directions.
- The door or the outer surface may get hot when the appliance is operating.
- Do not use this oven for purposes other than cooking.
- Use caution if opening the door when the oven is operating. Hot surfaces can cause serious burns.
- In order to avoid a hazard due to inadvertent resetting of the thermal cut-out, this appliance must not be supplied through an external switching device, such as a timer, or connected to a circuit that is regularly switched on and off by the utility.
- Excess spillage must be removed before cleaning.
- When using cleaning mode, remove the baking tray, deep baking tray, wire grill, all cookware, aluminum foil, or any other material from the oven.
- Only use the recommended probe temperature for this oven model.

Maintenance

- Do not repair or replace any part of the appliance unless specifically recommended in the manual. All other servicing should be performed by a qualified technician.
- Do not use harsh etching, abrasive cleaners or sharp metal scrapers to clean the oven door glass since they can scratch the surface. Scratches can cause the glass to shatter.
- Make sure oven lights are cool before cleaning.
- Do not clean the door gasket. The door gasket is essential for a good seal. Care should be taken not to rub, damage, or move the gasket.
- Do not rinse trays and racks by placing them in water just after cooking. This may cause breakage or damage.
- The oven should be cleaned regularly and any food deposits should be removed. Failure to maintain the oven in a clean condition could lead to deterioration of the surface that could shorten the life of the appliance and possibly result in a hazardous situation.
- Never use oven cleaner in the cooking compartment when it is still warm, and never heat up the oven unless all oven cleaner has been wiped off.
- Do not clean the accessories in a dishwasher.
- Do not use oven cleaners, steam cleaners, harsh chemical cleaners, bleach, vinegar, steel scouring pads, or abrasive pads or cleansers to clean the oven, as they can permanently damage the oven surface.

Using Steam Function

- Hot steam may cause scalding.
- Don't open the door and don't touch the vent holes while steam function is working.
- Use care when opening the door. The hot air and steam that escape can cause burns to hands, face and eyes. Let hot air or steam escape from the oven before opening the door.
- Steam may condense on the inside of the door. Do not wipe condensation off until the door has cooled.

CARING FOR THE ENVIRONMENT

Disposal

CAUTION

- Your new oven has been correctly packaged for transportation. Remove all of the packaging material before putting the appliance into use.
- Do not forget to remove the foils from the telescoping runners and from the control panel.

Single material of packaging

Packaging material		Alphabetical	Numerical
Plastic	Polyethylene terephthalate	PET	1
	High-density polyethylene	HDPE	2
	Polyvinylchloride	PVC	3
	Low-density polyethylene	LDPE	4
	Polypropylene	PP	5
	Polystrene	PS	6
Paper & Cardboard	Corrugated board	PAP	20
	Another board	PAP	21
	Paper	PAP	22
Metals	Steel	FE	40
	Aluminum	ALU	41

Packaging material		Alphabetical	Numerical
Wood	Wood	FOR	50
	Cork		51
Textile	Cotton	TEX	60
	Jute		61
Glass	Clear glass	GL	70
	Green glass		71
	Brown glass		72

- If you wish to store your oven away temporarily, choose a dry, dust-free place. Dust and damp may adversely affect the working parts in the oven.

Used Appliances

CAUTION

- Used appliances must be rendered unusable prior to disposal so that they no longer present a risk. To achieve this, disconnect from the mains supply and remove the power supply cable.

For the protection of the environment, used appliances must be disposed of properly.

- The appliance must not be disposed of along with normal domestic waste.

INSTALLATION INSTRUCTIONS

Installation should be undertaken by a qualified professional electrician only.

Safety Instructions for the Installer

The oven must be installed in compliance with the manufacturer's instructions. For more information about installation, please refer to the installation manual.

- Do not install the appliance if there is a transport damage. Contact an LG Electronics customer information centre.
- During installation, ensure that no persons can come into contact with live components.
- The oven must be installed by a qualified professional electrician, in accordance with the corresponding regulations and standards.
- The oven is a heavy appliance and must be transported with great care at least by two persons.
- Before initial use, remove all packaging, both external and from inside the appliance.
- No modification may be made to the oven's technical characteristics.
- Disconnect the electrical power to the appliance at the main fuse or circuit breaker panel. Failure to do so can result in severe personal injury, death, or electrical shock.
- Make sure to slide the tray and wire grill in a correct position as the telescopic runner pins are inserted through the holes on both sides.

Electrical connection

The range should always be plugged into its own individual properly grounded electrical outlet.

- This prevents overloading house wiring circuits which could cause a fire hazard from overheated wires.
- It is recommended that a separate circuit serving only this appliance be provided.
- Connection of this appliance must comply with national and local safety regulations.
- Connection to a switched socket is recommended as this provides easier access in the case of a service call.

- For extra safety, it is advisable to protect the appliance with a suitable residual current device (RCD) with a trip current of 30 mA.
- If the switch is not accessible after installation an additional means of disconnection must be provided for all poles. The means of disconnection must be incorporated in the fixed wiring in accordance with the wiring rules.
- When switched off there must be an all pole contact gap of 3 mm in the isolator switch (including switch, fuses and relays).
- Connection data
 - Blue : Neutral Wire
 - Green + Yellow : Ground Wire
 - Brown : Live Wire
 - The voltage and rated load are given on the data plate situated at the front of the oven frame visible with the oven door open. Please ensure the connection data matches the household supply.
- This appliance incorporates an earth connection for functional purposes.

PRODUCT OVERVIEW

Product Features

Exterior / Interior

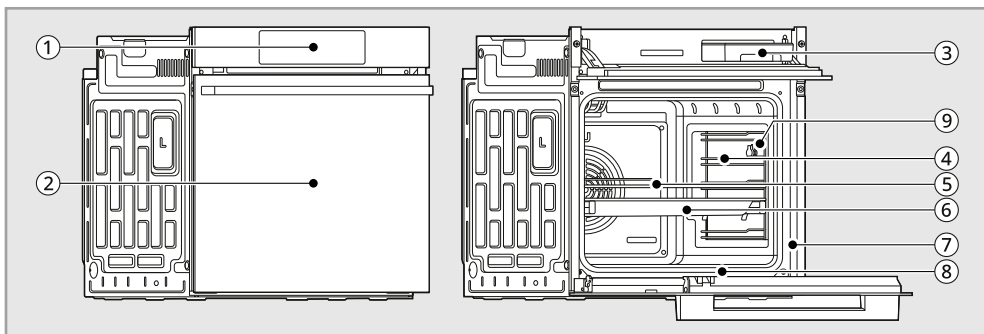

①	Oven Controller	⑥	Baking Tray
②	Oven Door	⑦	Rating Label, Model and Serial Number Plate
③	Water Tank	⑧	Gasket
④	Rail Rack (2 ea)	⑨	Meat Probe Socket (Model WSED7667M)
⑤	Wire Grill		

NOTE

- The model and serial number can be verified at the rating label.

Accessories

Accessories for Cooking

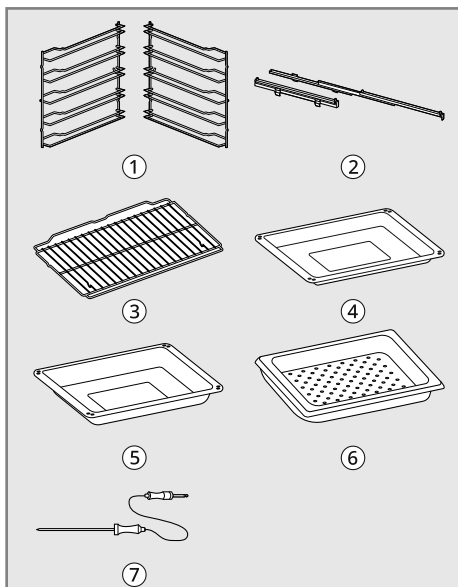

①	Rail Rack (2 ea)
②	Telescopic Runner (2 ea)
③	Wire Grill (1 ea)
④	Baking Tray (1 ea)
⑤	Deep Pan (1 ea)
⑥	Perforated Tray (1 ea) • Model WSED7667M
⑦	Meat Probe (1 ea) • Model WSED7667M

Accessories for Installation

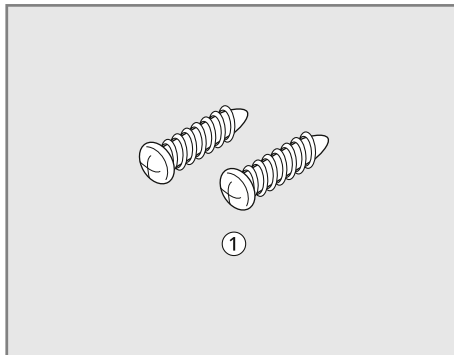

①	Wood Screws for Mounting (2 ea)
---	---------------------------------

Manuals

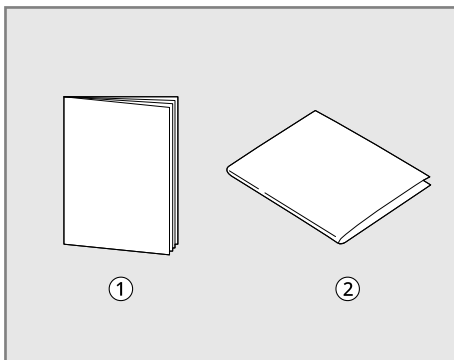

①	Owner's Manual
②	Installation Guide

⚠ WARNING

- After installation, pull off the protection film from the control panel as well as from the telescoping runners.

NOTE

- Contact your LG Electronics customer information center if any accessories are missing for your particular model.

-
- For your safety and for extended product life, only use authorized components.
 - The manufacturer is not responsible for product malfunction or accidents caused by the use of separately purchased, unauthorized components or parts.
 - The images in this guide may be different from the actual components and accessories, which are subject to change by the manufacturer without prior notice for product improvement purposes.
-

OPERATION

Operating Control Panel

Control Panel Features

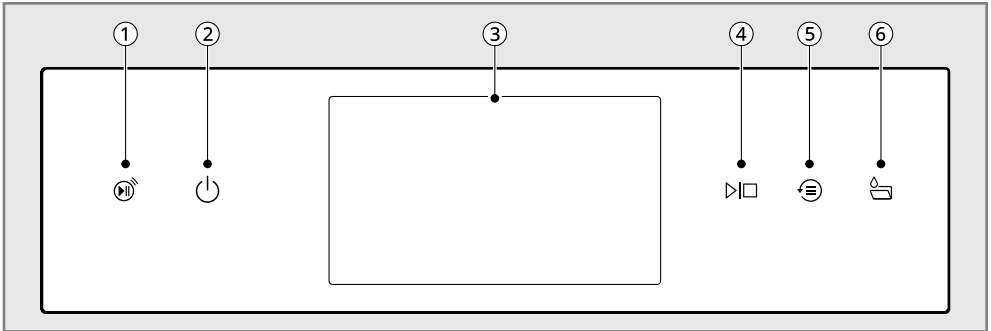





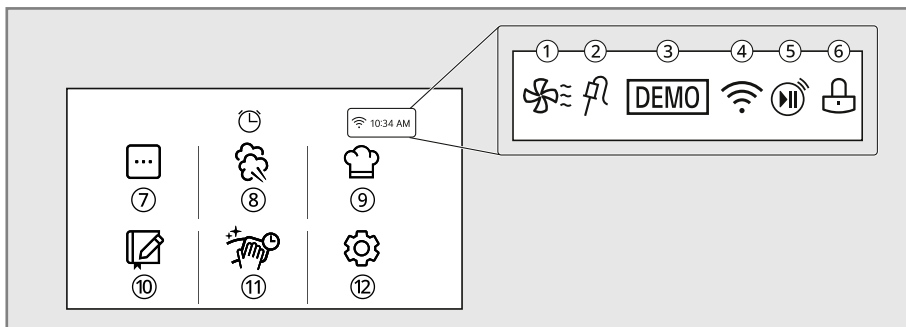

①	Remote Start Indicator
②	Power On/Off
③	LCD Touchscreen
④	Start/Stop
⑤	Recent Cook
⑥	Water Tank

Display Icons

Icons appear in display when activated.



	<p>① Oven Cooling Appears during or after oven operation to indicate cooling fan is running in the oven.</p>
	<p>② Probe Appears when probe is connected. (Model WSED7667M)</p>
	<p>③ Demo Appears when Demo mode is active.</p>
 	<p>④ Wi-Fi</p> <ul style="list-style-type: none"> • Appears when oven is connected to Wi-Fi. • Appears when oven is not connected to Wi-Fi.
	<p>⑤ Remote Start Appears when Remote Start is active.</p>
	<p>⑥ Lock Appears when Control Lock is activated. Once the door has been locked, the lock indicator light stops flashing and remains on.</p>

⑦	Manual Cook
⑧	Steam Cook
⑨	Recipe Cook
⑩	My Recipes
⑪	Cleaning
⑫	Settings

Energy Saving Tips

- Multiple-rack cooking saves time and energy. Whenever possible, cook foods requiring the same cooking temperature together in one oven.
- For optimal performance and energy savings, follow the guides for proper rack and pan placement.
- Reduce energy use by cleaning light oven soil with the **EasyClean** feature.
- Avoid opening the oven door more than necessary during use. This helps the oven maintain temperature, prevents unnecessary heat loss, and saves on energy use.

Changing Settings

Getting Started

After turning on the oven for the first time, adjust the settings to suit your preferences.

- 1) Press the **Power On/Off** button on the control panel if the LCD display is turned off.
- 2) After the startup animation, select the desired language, then press **Next**.
- 3) Set the time, then press **Done**.
- 4) The **Main Menu** screen appears in the display.

NOTE

- These settings are stored in memory, see **Time** and **Language** section to change.

Settings

To adjust settings after the initial setup, press the **Power On/Off** button to open the **Main Menu** screen. Press **Settings** at the bottom right of the **Main Menu** screen.

Swipe the screen to navigate through the **Settings** screens.

Control Lock

The **Control Lock** feature automatically prevents most oven controls from being turned on. All function are disabled except the **Power On/Off** button. It does not lock the oven door.

Lock

- 1) Press **Settings** at the right bottom of the **Main Menu** screen, and press **Control Lock**.
- 2) When **Control Lock** is activated, the lock icon  appears at the top of the display.

Unlock

- 1) Press any part of screen while **Control Lock** is on.
- 2) A popup screen appears. Press and hold **Unlock** for 3 seconds until the countdown ends.
- 3) The lock icon  disappears from the top of the display.

Time

The time shows in the LCD display.

Setting Time of Day

- 1) Press **Settings** at the right bottom of the **Main Menu** screen, then press **Time**.
- 2) Press **Current Time**. Press **▲** or **▼** to raise or lower the numbers, then press **←** several times to save the settings until the **Main Menu** screen is displayed.

You can also use the number pad icon to set the correct hour and minutes directly, then press **OK**.

- 3) Press **←**.

Setting Time Format

- 1) Press **Settings** at the right bottom of the **Main Menu** screen, then press **Time**.
- 2) Press **Time Format** and select a 12-hour or 24-hour clock mode.

Wi-Fi

Connect the appliance to a home Wi-Fi network to use Remote Start and other smart functions. See the Smart Functions section for more details.

Setting Up Wi-Fi

- 1) Press **Settings** at the right bottom of the **Main Menu** screen, then press **Wi-Fi**.
- 2) Press **Set Up Wi-Fi**.
- 3) Follow the instructions in the Wi-Fi Guide in the display.

Resetting Wi-Fi

- 1) Press **Settings** at the right bottom of the **Main Menu** screen, then press **Wi-Fi**.
- 2) Press **Reset Wi-Fi**.
- 3) Follow the instructions in the Wi-Fi Guide in the display.

Remote Start

This feature can be used with the **Manual Cook** modes. Remotely starts or stops the cooking operation. The appliance must be connected to a home Wi-Fi network to use Remote Start.

Setting Remote Start (network port activation or deactivation)

- 1) Press **Settings** at the right bottom of the **Main Menu** screen, then press **Remote Start**.
- 2) Select **On** to activate remote start or **Off** to deactivate it.
- 3) If **On** is selected, the **Remote Start** icon  appears at the top of the display.
"Remote Start is on. Check the LG ThinQ app to use Remote Start." appears in the display when the **Remote Start** is activated.
- 4) Follow the instructions in the LG ThinQ app for using the Remote Start function.

Start Screen

There are five different screen themes available.

Setting Start Screen

- 1) Press **Settings** at the right bottom of the **Main Menu** screen, then press **Start Screen**.
- 2) Select the desired start screen theme.

Brightness

Adjust the brightness of the LCD display from Level 1 (20 %) to Level 5 (100 %) in increments of 20 %.

Setting Display Brightness

- 1) Press **Settings** at the center bottom of the **Main Menu** screen, swipe the Settings screen, then press **Brightness**.
- 2) Adjust the display brightness by pressing and dragging the dot across the bar, by tapping anywhere on the bar, or by pressing **+** or **-**.

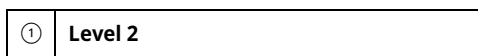
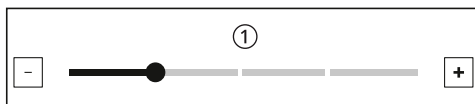

- 3) Press **←**.

Language

Set the display language.

Selecting a Language

- 1) Press **Settings** at the right bottom of the **Main Menu** screen, swipe the Settings screen, then press **Language**.
- 2) Select the desired language.

Volume

Adjust the volume of the following features: Oven start, Button operation, End of cooking, Preheating complete.

Setting the Volume

- 1) Press **Settings** at the right bottom of the **Main Menu** screen, swipe the Settings screen, then press **Volume**.
- 2) Select **Mute, Low, or High**.
- 3) Press ←.

InstaView

Knock twice on the center of the glass panel to reveal the contents of the oven without opening the door.

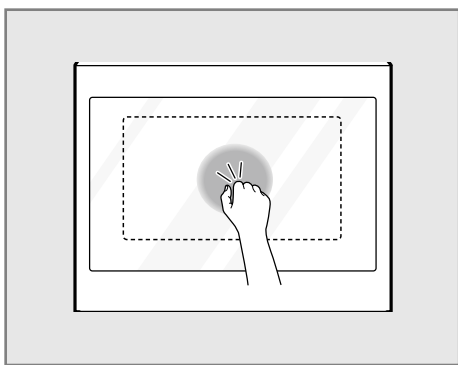

⚠ CAUTION

- Do not hit the glass door panel with excessive force. Do not allow hard objects like cookware or glass bottles to hit the glass door panel. The glass could break, resulting in a risk of personal injury.

NOTE

- Knocking twice on the glass panel turns the interior light on or off.
- The light stays ON during cooking.
- The light turns off automatically after 5 minutes and switches to standby mode when cooking is finished or the oven is not in operation.
- The InstaView function is disabled when the oven door or oven controller is opened and for one second after closing the door.

- The InstaView function is disabled during **Control Lock** Mode and initial power input (on some models only).
- Tapping the edges of the glass panel may not activate the InstaView function.
- The taps on the glass panel must be hard enough to be audible.
- The taps on the control panel or loud noises near the oven may activate the InstaView function.

Setting InstaView

- 1) Press **Settings** at the right bottom of the **Main Menu** screen, then press **InstaView**.
- 2) "**Knock twice on the centre of the glass panel to reveal the contents of the oven without opening the door**" appears in the display when the **InstaView** feature is activated. Press **OK**.

Preheat Light

When the oven reaches its set-temperature, the preheating light flashes 5 times or until the oven door is opened.

You can turn the preheat light on or off.

Setting the Preheat Light

- 1) Press **Settings** at the right bottom of the **Main Menu** screen, swipe the screen, then press **Preheat Light**.
- 2) Select **On** or **Off**.

Temperature Adjustment

Your new oven may cook differently than the one it replaced. Use your new oven for a few weeks to become more familiar with it before changing the temperature settings. If after familiarizing yourself with the new oven, you still think that it is too hot or too cold, you can adjust the oven temperature yourself.

NOTE

- To begin, either raise or lower the temperature 19 °C. Try the oven with the new setting. If the oven still needs adjustment, raise or lower the

temperature again, using the first adjustment as a gauge. For example, if the adjustment was too much, raise or lower the temperature 5 °C. If the adjustment was not enough, raise or lower the temperature 12 °C. Proceed in this way until the oven is adjusted to your satisfaction.

Adjusting the Temperature

- 1) Press **Settings** at the right bottom of the **Main Menu** screen, swipe the screen, then press **Temperature Adjustment**.
- 2) Press **▲** or **▼** to raise or lower the temperature in 1-degree increments. Press and hold **▲** or **▼** to scroll up or down the scale.

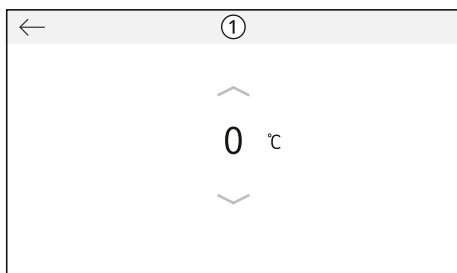

①	Temperature Adjustment
---	-------------------------------

- 3) When the desired change appears above the range, press ←.

Smart Diagnosis

Smart Diagnosis can be run through a smartphone application or by calling for support. Place your smartphone's mouthpiece near the top left corner of the screen. See "Smart Diagnosis Function" in the Smart Functions section for detailed instructions.

- 1) Press **Settings** at the right bottom of the **Main Menu** screen, swipe the screen, then press **Smart Diagnosis**.
- 2) Press **START** to start the diagnostic tone.

Factory Data Reset

This function returns all settings to the factory defaults.

⚠ CAUTION

- All stored data will be deleted.

- 1) Press **Settings** at the right bottom of the **Main Menu** screen, swipe the screen, then press **Factory Data Reset**.
- 2) If you want to reset data to the factory defaults, press **RESET**. A popup will appear in the display, then press **RESET**.

Demo Mode

Demo Mode for showroom use only. The oven will not heat up.

- 1) Press **Settings** at the right bottom of the **Main Menu** screen, swipe the screen, then press **Volume**.
- 2) Tap the upper right corner of the screen 15 times to enable or disable demo mode.
 - **DEMO** is displayed in the right corner of the **Main Menu** screen.

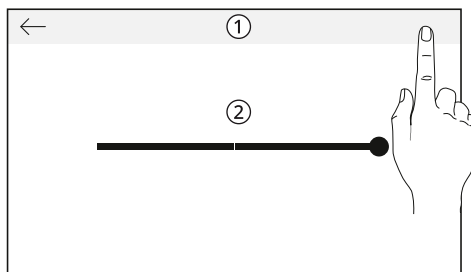

①	Volume
②	High

- 3) To deactivate the mode, repeat step 1) and 2) again.

NOTE

- When Demo Mode is on, the appliance will not heat up.
- The oven Demo Mode icon appears in the display if the Demo Mode is on.

Oven Cooling

The oven cooling icon  appears in the display if the temperature inside the oven is high during or after operation. The oven cooling icon disappears if the oven temperature is low.

The oven cooling icon  disappears if the oven temperature is low.

- In some modes, the cooling fan can be operated regardless of the oven temperature.

Timer

The oven timers don't affect oven operation or cooking time. Use them as extra kitchen timers. Once the time runs out, the oven chimes and **Timer Ended** appears in the display.

Setting the Timer

- 1) Press the clock icon  at the center top of the display.
- 2) Scroll through the numbers in the popup until the desired time appears in the display, then press **START**.

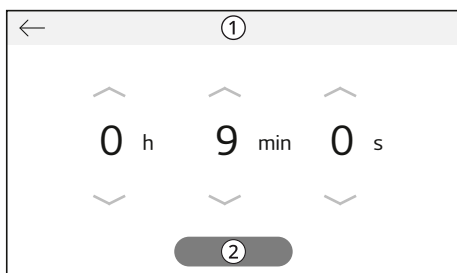

① **Timer**

② **START**

- 3) The time remaining appears next to the clock icon in the display.

A chime sounds when the set time runs out and **Timer Ended** appears in the display. The chime sounds every 15 seconds until **OK** is pressed.

Adjusting or Cancelling the Timer

- 1) Press the remaining time next to the clock icon in the display.
- 2) To cancel the timer, press **STOP** in the display.
- 3) To adjust the time, scroll through the numbers in the popup until the desired time appears in the display, then press **RESTART**.
- 4) The remaining time in the display is adjusted.

Operating the Oven**Before Using the Oven****NOTE**

- Because the oven temperature cycles, an oven thermometer placed in the oven cavity may not show the same temperature that is set on the oven.
- The heating turns off if the door is open during operating. The heat turns back on automatically once the door is closed.
- Avoid opening the oven door more than necessary during use. This helps the oven maintain temperature, prevents unnecessary heat loss, and saves on energy use.

Oven Vent

Areas near the vent may become hot during operation and may cause burns. Avoid placing plastics near the vent as heat may distort or melt the plastic.

It is normal for steam to be visible when cooking foods with high moisture content.

⚠ WARNING

- Do not block the vent between the oven door and the controller.

Assembling Rail(Telescopic) Rack**⚠ WARNING**

- Remove the protection film from all telescopic runners.

Assemble the rail racks on both sides of the oven cavity before operating the oven for the first time.

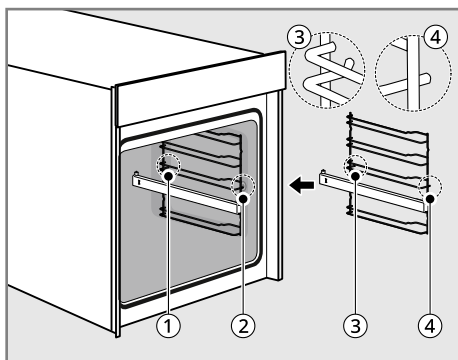

①	Rear Hole
②	Front Hole
③	Rear Rail Rack Hook (curved)
④	Front Rail Rack Hook (straight)

- Align the rack inside the oven cavity. So that the curvature of the rack is pointing to the oven door.
- Insert the rear rail rack hook ③ into the oven cavity hole ①.
- Insert the front rail rack hook ④ into the oven cavity hole ② and press down to secure the fitting.

- Repeat steps 1-3 for the other side of the oven cavity.

Removing Rail Rack**⚠ WARNING**

- Do not touch the oven racks while they are hot.

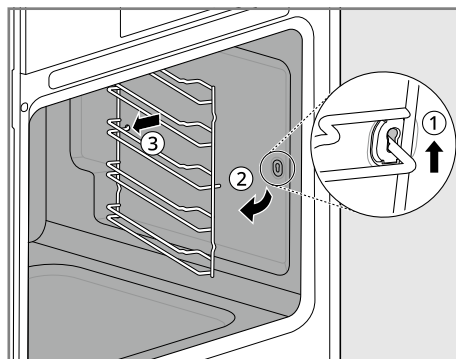

- Lift up the rack slightly ①.
- Pull the front of the rack away from the side wall ②.
- Continue to Swing the front of the rack to the center of the oven ② while pulling the rear of the rack away from the side wall to release its hook ③.
- Repeat steps 1-3 for the other side of the oven cavity.

Using the Telescopic Runners**Installing the Telescopic Runners**

Install the telescopic runners before operating the oven for the first time.

⚠ WARNING

- Allow the oven to cool before installing or removing the telescopic runners to prevent burns.

NOTE

- Place a soft cloth on the floor to avoid damaging the parts. It is essential that the telescopic runners are fitted and secured correctly. Failing to do so could cause the runner and its contents to fall causing serious damage to the oven.

- 1) Check the telescopic runner direction, as the long part of the telescopic clip facing down and the pins of the telescopic runner are pointing upwards.

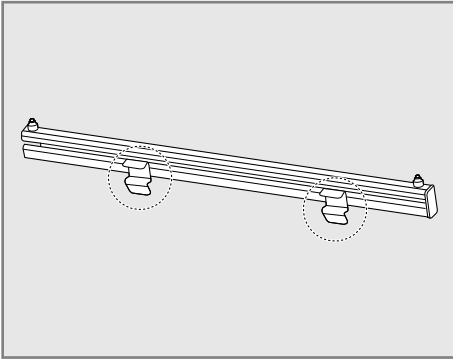

- 2) Place the telescopic runner parallel with the rail rack horizontally.

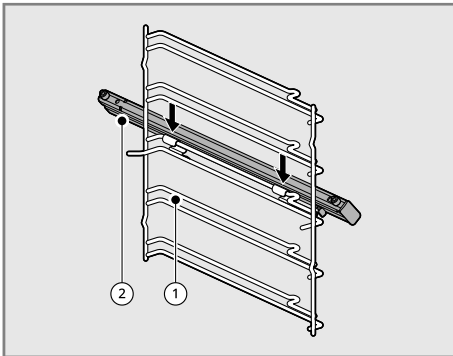

①	Rail Rack
②	Telescopic Runner

- 3) Hook both the telescopic runner clips onto the upper rail of the desired rack position.

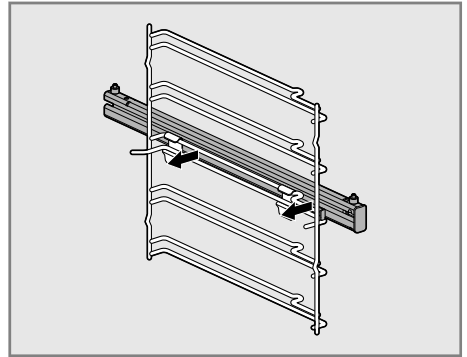

- 4) Place the telescopic runner onto the rail rack until the lower part of the telescopic runner clip buckle clips onto the lower rail of the desired rack position.
- 5) Repeat steps 1-4 for the other telescopic runner to install on the other side.

Removing the Telescopic Runners

⚠ WARNING

- Allow the oven to cool before installing or removing the telescopic runners to prevent burns.

NOTE

- Place a soft cloth on the floor to avoid damaging the parts. It is essential that the telescopic runners are fitted and secured correctly each time. Failing to do so could cause the runner and its contents to fall causing serious damage to the oven.

- 1) Pull forward the telescopic runner clips

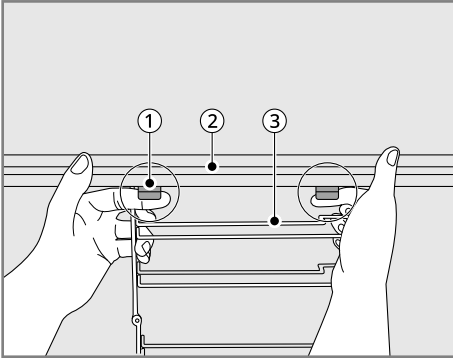

①	Telescopic Runner Clip
②	Telescopic Runner
③	Rail Rack

- 2) Lift up the whole telescopic runner and pull it away to detach from the rail rack.

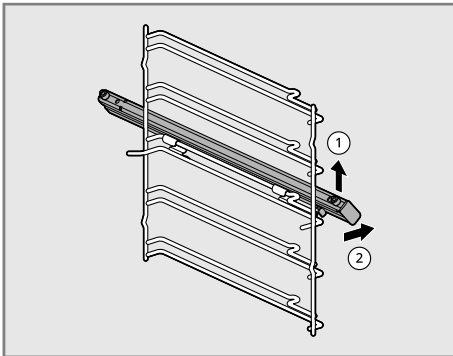

from sliding forward when the telescopic runner is completely extended.

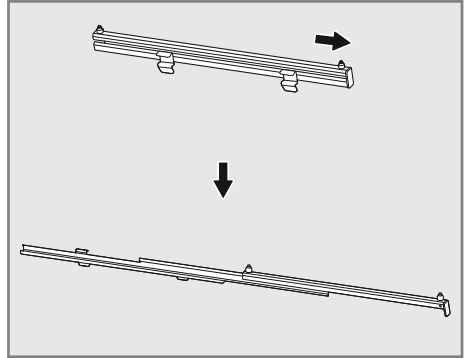

- Make sure to slide the tray and wire grill in a correct position as the telescopic runner pins are inserted through the holes on both sides.

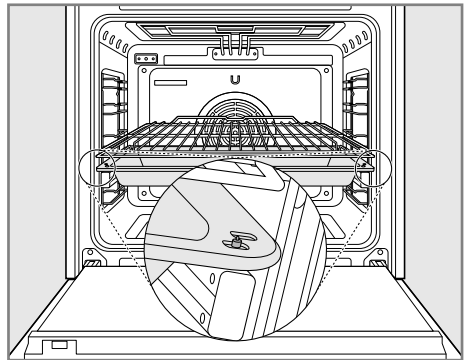





Using the Telescopic Runners



The telescopic runners slide in and out on a frame. This keeps heavy cookware level and prevents it

Manual Cook





Read the below guide and select the desired cooking mode to meet your specific cooking needs.



• ● : Available / X: Not available

Function	Temperature Range	Default Temperature	Option		Description
			Rapid Preheat >>	Probe \uparrow (WSED7667M)	
Hot Air 	30-275 °C (WSED7665B) 30-250 °C (WSED7667M)	160 °C	●	●	Hot Air mode uses only the heating element in the back wall and the convection fan. It is also possible to bake on more than one level in Hot Air mode. This means that it is suitable for fruit cakes and stirred cake or yeast-dough, for example a bread plait.
Economic Hot Air 	30-275 °C (WSED7665B) 30-250 °C (WSED7667M)	160 °C	X	X	Economic Hot Air mode uses the optimised heating system to save energy while cooking food. In this mode, residual heat can be used to conserve energy.
Top Bottom Heat 	30-300 °C (WSED7665B) 30-250 °C (WSED7667M)	170 °C	●	●	In Top Bottom Heat mode, the upper and concealed lower heating elements are used. This operating mode is suitable for baking cakes, baking for a short time, and sensitive doughs.
Roasting 	30-300 °C (WSED7665B) 30-250 °C (WSED7667M)	190 °C	X	●	In Roasting mode, the upper heating elements and the convection fan are on. This function is suitable for large pieces of meat or poultry, such as rolled roast or turkey.



Function	Temperature Range	Default Temperature	Option		Description
			Rapid Preheat >>	Probe π (WSED766 7M)	
Pizza Mode 	30-300 °C (WSED7665B) 30-250 °C (WSED7667M)	180 °C	X	X	In Pizza Mode mode, the concealed heating element at the bottom of the oven cavity and the element in the back wall and convection fan are activated. When using the Pizza Mode , the cooking time must vary depending on the type and thickness of the dough and topping.
Fan Assisted Air 	30-300 °C (WSED7665B) 30-250 °C (WSED7667M)	160 °C	●	X	In addition to the Top Bottom Heat mode (upper and concealed lower), the Fan Assisted Air mode uses the convection fan. This means that the roasting and baking temperature can be reduced by 20-40 °C. This mode is suitable for cakes and biscuits, as it is possible to bake on more than one level at the same time.
Large Grill 	High / Medium / Low	High	X	X	Large Grill mode uses the entire grill heating element. No specific temperature can be set. You can choose between three settings. The Large grill is suitable for cooking steaks, cutlets, fish or making toast, and for browning when cooking larger dishes with a gratin topping. The preset level is high. Always grill with the door closed.

32 OPERATION

Function	Temperature Range	Default Temperature	Option		Description
			Rapid Preheat >>	Probe π (WSED766 7M)	
Small Grill 	High / Medium / Low	High	X	X	Small Grill mode operates in the same way as the Large grill , however, only part of the grill heating element is used. This makes it suitable for smaller dishes. The preset level is High. Always grill with the door closed.
Bottom Heat 	30 - 250 °C	170 °C	X	X	In Bottom Heat mode, only the concealed heating element in the oven floor is used. This function is particularly suitable for finishing off cakes or pizzas on one of the lower oven levels.
Economic Top Bottom Heat 	30 - 300 °C (WSED7665B) 30 - 250 °C (WSED7667M)	170 °C	X	X	Economic Top Bottom Heat mode uses the optimised heating system to save energy while cooking food. In this mode, residual heat can be used to conserve energy. To avoid losing heat, always keep the door closed when cooking.
Air Fry 	150 - 275 °C (WSED7665B) 150 - 250 °C (WSED7667M)	200 °C	X	X	Air Fry function is specially designed for oil free frying.
Air Sous-Vide (WSED766 5B) 	30 - 100 °C	50 °C	X	X	Air Sous-Vide mode uses air to cook foods "low and slow". Use it to cook meat, fish, seafood, poultry or vegetables. Food must be vacuum packed in pouches before cooking

Function	Temperature Range	Default Temperature	Option		Description
			Rapid Preheat >>	Probe \uparrow (WSED766 7M)	
Drying 	30 - 150 °C	80 °C	X	X	Drying mode uses only the heating element in the back wall and the convection fan. For drying herbs, fruits and vegetables.
Warm 	40 - 100 °C	75 °C	X	X	In Warm mode, the heating element at the top and concealed element at the bottom of the oven cavity are activated. You can use this function for keeping food warm until ready to serve. In this mode, a selectable temperature from 40 to 100 °C can be set. The duration of this function can also be set.
Defrost 	-	-	X	X	In Defrost mode, only the fan is used without heating. The circulating air speeds up the defrosting process. Place the frozen food in a suitable container to trap the liquid produced during defrosting. Where appropriate, you can use the wire grill and a deep pan (or baking tray) to avoid soiling the oven. If water is allowed to run out into the oven, the door seal will be contaminated and an unpleasant odour may result.

34 OPERATION

Function	Temperature Range	Default Temperature	Option		Description
			Rapid Preheat >>	Probe $f\bar{n}$ (WSED766 7M)	
Frozen Meal 	30 - 250 °C	200 °C	X	X	For the quick preparation of frozen products. The temperature depends on the manufacturer's instructions. Use the highest temperature specified on the packaging. The cooking time is as specified or shorter.
Proof 	30 - 60 °C	40 °C	X	X	Proof mode maintains a warm oven for rising yeast leavened products before baking. To avoid lowering the oven temperature and lengthening proofing time, do not open the oven door unnecessarily. Check bread products early to avoid over proofing. Do not use the proofing mode for warming food or keeping food hot. The proofing oven temperature is not hot enough to keep foods at safe temperatures. Use the Warm feature to keep food warm.

Function	Temperature Range	Default Temperature	Option		Description
			Rapid Preheat >>	Probe \overline{fl} (WSED766 7M)	
Warm Dishes 	30 - 70 °C	50 °C	X	X	Warm Dishes mode is used to keep dishes warm evenly. In this operating mode, the system uses the convection heating element and fan located at the back of the oven to circulate warm air. A selectable temperature from 30 to 70 °C can be set. The duration of this function can also be set. Please ensure that the dishes are oven compatible.

Hot Air / Economic Hot Air

CAUTION

- Pressing the **Power On/Off** button during cooking clears all settings.

NOTE

- If no cook time is set, the oven turns off automatically after 12 hours.

Setting Hot Air / Economic Hot Air Mode

- 1) Press **Manual Cook** in the **Main Menu** screen.
- 2) Select **Hot Air** or **Economic Hot Air** in the cooking mode screen.
- 3) Press **Temp.** to set the desired cooking temperature. Press **▲** or **▼** to raise or lower the numbers, then press **←** to save the settings.

You can also use the number pad icon to set the cooking temperature directly, then press **OK**.

- 4) If desired, press **Time**.

And press **Cook Time** or **Cooking ends at.** to set the cook time or cooking end time.

Press **▲** or **▼** to raise or lower the numbers, then press **←** to save the settings.

You can also use the number pad icon to set the cooking time directly, then press **OK**.

- 5) Press the **Start/Stop** button on the control panel. The oven starts to preheat.
- 6) If the cook time is set, the remaining time appears in the display. If a cooking end time is set, the start time appears in the display.
- 7) A chime sounds once preheating is complete.
- 8) A chime sounds at the end of the set cook time and a notification appears in the display. Open the oven door and remove the food.

Changing the Hot Air or Economic Hot Air Settings

- 1) Press **Edit** to bring up the Cook Settings screen.
- 2) Adjust the settings using the number pad or scroll function.
- 3) Press the **Start/Stop** button on the control panel.

To Stop Cooking

- 1) Press the **Start/Stop** button on the control panel, then press **Stop** in the display.

NOTE

- The oven fan runs during the **Hot Air** cycle. The fan stops when the door is open. In some cases, the fan may shut off during the **Hot Air** cycle.

Tips for Hot Air

- Use **Hot Air** for faster and more even multiple-rack cooking of pastries, cookies, muffins, biscuits, and breads of all kinds.
- Bake cookies and biscuits on pans with no sides or very low sides to allow heated air to circulate around the food. Food baked on pans with a dark finish will cook faster.
- Multiple oven rack cooking may slightly increase cook times for some foods.
- Cakes, cookies and muffins have better results when using multiple racks.

Tips for Economic Hot Air

- When possible, do not preheat the oven before placing food inside.
- Only preheat if it is specified in the recipe.
- To maximise energy efficiency, do not open the door during cooking.
- Use dark black enameled tins that absorb heat particularly well.
- Remove unused accessories from the oven.

Recommended Economic Hot Air Guide

This table is intended as a guide only, individual tastes and cuts of meat will vary.

Always count the oven rack position from the bottom up.

The durations given are for an oven which has not been preheated.

- Rack: Rack Position

Food		Rack	Temp. (°C)	Time (minute)
In a baking tin	Flan base - cake mixture	3	150-170	35-45
	Spicy cakes and flan base (e.g. quiche lorraine)	2	160-180	30-70
On a baking tray	Pizza (thin base)	1	200-220	15-30
Biscuits	Iced	3	140-150	10-40
	Cake mixture	3	150-160	25-35
Meat	Beef (approx. 1 kg)	2	190	60-80
	Poultry (approx. 1 kg)	2	210	50-70
	Poultry (approx. 2 kg)	2	210	60-80

Baking

When baking, use the **Hot Air** or **Top Bottom Heat** modes.

Baking Tins

- When baking in **Top Bottom Heat** modes, use baking tins with a dark metal or coated surface.
- When baking with **Hot Air**, you can also use baking tins with a bright metal surface.
- Always place cake tins in the middle of the tray or wire grill.
- When baking with **Top Bottom Heat**, you can place two baking tins side by side in the oven. This means that the baking time is only slightly longer.

NOTE

- Included tray may differ depending on the product.

Oven Rack Position

The Oven Rack Positions are numbered from the bottom up.

When using **Top Bottom Heat**, you can bake on one rack only, for example on rack position ③.

When using **Hot Air**, you can bake sponge bases and biscuits on up to two baking trays at the same time, for example on rack position ② and ④.

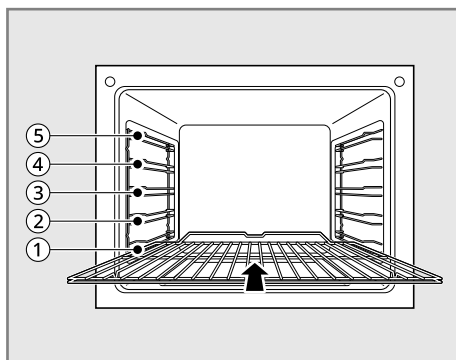

Recommended Baking Guide

The baking guide contains the temperature settings, baking times and oven rack positions for a selection of typical dishes.

- Temperatures and baking times should be regarded as reference figures only. The actual values depend on the type of preparation, quality of ingredients and the baking tin in use.
- We recommend first selecting a lower temperature and then increasing it if necessary, for example if you want a higher degree of browning or the baking time is too long.
- If you cannot work out the settings for a specific recipe, simply use the settings for the most similar recipe.

- When baking cakes on baking trays or in tins on more than one rack, the baking time may be extended by 10-15 minutes.
- Foods with a high liquidity content (e.g. pizza, fruit cakes, etc.) should be baked on a single rack only.
- With cakes and baked items with different racks of dough, uneven browning may take place initially. In this case, do not alter the temperature setting. The degree of browning will even itself out over the baking process.
- For energy saving, use the residual heat for 8 minutes before you finish cooking.



NOTE



- Always count rack position from the bottom up.



Baking on a single oven rack

- Rack: Rack Position

Cakes in baking tins					
Cook Mode	Hot Air		Top Bottom Heat		Time (minute)
	Rack	Temp. (°C)	Rack	Temp. (°C)	
Ring-shaped pound cake	2	150-160	2	160-180	50-70
Biscuits / pancakes	2	140-160	2	150-170	30-60
Sponge finger	2	150-160	2	160-180	25-40
Flan base – shortcrust pastry	3	170-180	2	190-210 *1	10-25
Flan base – cake mixture	3	150-170	2	170-190	20-25
Apple pie	3	160-180	1	170-190	65-75
Spicy cakes and flan base (e.g. quiche lorraine)	2	160-180	2	190-210	30-70
Cheesecake	2	140-160	2	170-190	60-90

Cakes on baking tray					
Cook Mode	Hot Air 		Top Bottom Heat 		Time (minute)
	Category	Rack	Temp. (°C)	Rack	
Bread plaits / larger cakes	3	160-170	4	170-190	30-40
Christmas stollen	3	150-170 *1	4	160-180 *1	40-60
Bread (rye bread) Fermentation is required	2	180-200 *1 140-160	2	230 *1 160-180	20 30-60
Pie / eclair	3	160-170 *1	4	190-210	15-30
Swiss roll	3	150-170 *1	4	180-200 *1	10-20
Fruit cake with shortcrust pastry	3	160-170 *1	4	170-190 *1	40-80
Slices with topping / filling e.g. quark, cream, sugar, almonds	-	-	4	160-180 *1	40-80
Pizza (thick base) *2*3	1	180-200	1	190-210 *1	30-60
Pizza (thin base) *2	1	200-220	1	230 *1	10-25
Unleavened bread	1	200-220	1	230 *1	08-15
Swiss flan	1	180-200	1	210-230	35-50

Biscuits					
Cook Mode	Hot Air 		Top Bottom Heat 		Time (minute)
	Category	Rack	Temp. (°C)	Rack	
Shortcrust biscuits *2	3	150-160	4	170-190 *1	06-20
Iced biscuits *2	3	140-150	4	160-180	10-40
Cake mixture biscuits *2	3	150-160	4	170-190	15-20
Cakes and pastries with egg white, meringues	3	80-100	4	100-120	120-150

Biscuits					
Cook Mode	Hot Air 		Top Bottom Heat 		Time (minute)
	Category	Rack	Temp. (°C)	Rack	
Macaroons	3	100-120	4	120-140	30-60
Yeast dough biscuits *2	3	160-170	4	170-190	20-40
Puff pastry cakes and pastries	3	160-180 *1	4	190-210 *1	20-30
Bread rolls	3	180-200 *1	4	180-220 *1	20-35

*1 Preheat the oven.

*3 Use deep pan (or baking tray).

*2 Always switch off **Rapid Preheat** when baking on more than one oven rack.

Baking on more than one oven rack

- Rack: Rack Position

Cakes /cakes and pastries on baking sheet			
Category	Hot Air 		Time (minute)
	Rack	Temp. (°C)	
Pie / eclair *2	2, 4	160-180 *1	35-60
Dry sponge cake with crumble topping *2	2, 4	140-160	30-60
Shortcrust biscuits *2	2, 4	150-160	15-35
Iced biscuits *2	2, 4	140-150	20-60
Cake mixture biscuits *2	2, 4	160-170	25-40
Cakes and pastries with egg white, meringues *2	2, 4	80-100	130-170
Macaroons *2	2, 4	100-120	40-80
Yeast dough biscuits *2	2, 4	160-170	30-60

Cakes /cakes and pastries on baking sheet			
Category	Hot Air 		Time (minute)
	Rack	Temp. (°C)	
Puff pastry cakes and pastries *2	2, 4	170-180 *1	30-50
Bread rolls *2	2, 4	180-190 *1	30-55

NOTE

- This is optional for products with two trays.
- Place the deep pan (or baking tray) on rack position ⑤.

*1 Preheat the oven.

*3 Use deep pan (or baking tray).

*2 Always switch off **Rapid Preheat** when baking on more than one oven rack.

Guide for strudel and baked dishes

- Rack: Rack Position

Category	Top Bottom Heat 		Time (minute)
	Rack	Temp. (°C)	
Baked Pasta	1	180-200	45-60
Lasagne	1	180-200	30-60
Baked Vegetables	1	200-220 *1	15-30
Pizza Baguette	1	200-220 *1	15-30
Soufflé	1	180-200	20-50
Fish Pie	1	180-200	30-60
Stuffed Vegetables	1	180-200	30-60

*1 Preheat the oven.

*2 Always switch off **Rapid Preheat** when baking on more than one oven rack.

42 OPERATION

*3 Use deep pan (or baking tray).

Guide for frozen ready-made dishes

- Rack: Rack Position

Category	Top Bottom Heat		Time (minute)
	Rack	Temp. (°C)	
Frozen pizza	3	Follow instructions on pack.	Follow instructions on pack.
Baguette	3	Follow instructions on pack.	Follow instructions on pack.
Fruit Cake Base	3	Follow instructions on pack.	Follow instructions on pack.
Chips	3	200-220	15-25

NOTE

- Turn chips 2 or 3 times when heating.
- When heating frozen dishes, the baking tray may bend out of shape because of the great difference in the temperature of the frozen food and the oven. Trays normally return to their original shape once they have cooled down.

Tips for baking

Results of Baking	Possible Cause	Solution
The cake base is too light	Wrong oven rack position	Use a dark baking tin or put the cake one rack lower down.
Cake collapses (turns lumpy, soggy)	Oven temperature too high	Set the temperature slightly lower.
	Baking time too short	Set a longer baking time. The baking time cannot be reduced by setting a higher temperature.
	Mixture contains too much liquid	Use less liquid. Follow instructions for dough mixing times, especially when using kitchen appliances.
Cakes are too dry	Oven temperature too low	Next time set a slightly higher temperature.
	Baking time too long	Set a slightly shorter baking time.

Results of Baking	Possible Cause	Solution
Cakes are browned unevenly	Baking temperature too high and baking time too short	Set a slightly lower baking temperature and a slightly higher baking time.
	Mixture unevenly distributed	Distribute the mixture evenly over the baking tray/tin.
Baking time too long	Temperature too low	Next time set a slightly higher temperature.

Roasting

When roasting, use the **Roasting** or the **Top Bottom Heat** mode.

The roasting guide contains the required temperatures, roasting times and oven rack positions for various kinds of meat. The figures stated are approximate figures only.

- We recommend cooking meat and fish weighing over 1 kg in the oven.
- For lean meat and fish, use **Top Bottom Heat**. For all other kinds of meat we recommend **Roasting** mode.
- Add a little liquid to prevent roasting juices or fat from getting burned onto the pan surfaces.
- Turn the food over after about half or two thirds of the cooking time.

WARNING

- Allow the oven to cool down enough to ensure there is no risk of burning yourself.

NOTE

- This roasting guide is intended as a guide only, individual tastes and cuts of meat will vary.

Setting Roasting Mode

- 1) Press **Manual Cook** in the **Main Menu** screen.
- 2) Select **Roasting** in the cooking mode screen.
- 3) Press **Temp.** to set the desired cooking temperature. Press **▲** or **▼** to raise or lower the numbers, then press **←** to save the settings.

You can also use the number pad icon to set the cooking temperature directly, then press **OK**.



- 4) If desired, press **Time**.

And press **Cook Time** or **Cooking ends at.** to set the cook time or cooking end time. Press **▲** or **▼** to raise or lower the numbers, then press **←** to save the settings.

You can also use the number pad icon to set the cooking time directly, then press **OK**.

- 5) Press the **Start/Stop** button on the control panel. The oven starts to preheat.
- 6) If the cook time is set, the remaining time appears in the display. If a cooking end time is set, the start time appears in the display.
- 7) A chime sounds once preheating is complete.
- 8) A chime sounds at the end of the set cook time and a notification appears in the display. Open the oven door and remove the food.

Recommended Roasting Guide

Food	Rack Position	Roasting 		Top Bottom Heat 	
		Temp. (°C) *1	Time (minute)	Temp. (°C) *1	Time (minute)
Beef (approx. 1 kg)	2	190	50-70	200	70-90
Venison (approx. 1 kg)	2	180	75-100	200-230	100-120
Leg of lamb (approx. 1 kg)	2	180	110-130	200	150
Poultry (approx. 1 kg)	2	210	50-60	200-220	70-90
Poultry (approx. 2 kg)	2	200	60-80	200-220	110-120
Poultry (approx. 4 kg)	2	180-190	120-140	190-210	130-150

Food	Rack Position	Roasting		Top Bottom Heat	
		Temp. (°C) *1	Time (minute)	Temp. (°C) *1	Time (minute)
Whole fish (approx. 1.5 kg)	2	160-180	35-55	200-220	35-55

*1 Set the pot roasting temperature 20 °C higher.

Tips for Roasting

- For better roasting results, baste joints and poultry with their own juices a number of times during the roasting process.
- Use heat resistant dishes when roasting (follow manufacturer's instructions).
- Stainless steel roasting pans are only of limited use, as they reflect the heat to a very large extent.
- When using dishes with plastic handles, ensure that the handles are heat resistant (follow manufacturer's instructions).
- Large items for roasting or a number of items can be placed directly on the wire grill above the deep pan (or baking tray) (e.g. turkey, goose, 3~4 chickens, 3~4 knuckles of veal).
- Lean meat should be roasted in a roasting tray with a lid (e.g. veal, braised beef, deep frozen meat). This keeps the juices in the meat.
- Pour enough water into the deep pan (or baking tray) to prevent smoke generation when you use roasting mode.
- Clean the oven as soon as possible after use if you are roasting in an open-topped tin or dish. It is easier to remove fat splashes when the oven is still warm.

meat or into the inner thigh or breast of poultry, away from fat or bone. Place food in the oven and connect the meat probe to the jack. Keep the probe as far away from heat sources as possible.

- The probe can be used in the **Hot Air, Top Bottom Heat** or **Roasting** modes.
- For thin cuts of meat, insert probe in thickest side of meat.

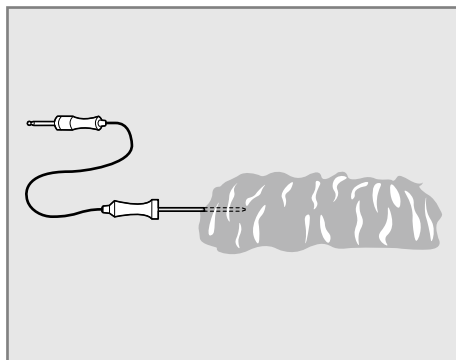

NOTE

- Only use the recommended probe temperature for this oven model.

Using the Meat Probe Feature

⚠ CAUTION

- Always use an oven mitt to remove the temperature probe. Do NOT touch the grilling element. Failure to follow this warning can result in severe personal injury.
- To avoid damage to the meat probe, do not use tongs to pull on the probe when removing it.

Probe Mode (Model WSED7667M)

The probe accurately measures the internal temperature of meat, poultry and casseroles. Always unplug and remove the probe from the oven before removing food. Before using, insert the probe into the center of the thickest part of

⚠ CAUTION

- Do not store the meat probe in the oven.

NOTE

- To avoid breaking the probe, make sure food is completely defrosted before inserting the probe.
- See the Recommended Probe Temperature Chart to set the probe temperature.

- 1) Insert the probe into the food.
- 2) Open the flap upwards and connect the probe to the jack in the oven. **Probe connected** appears in the display and the probe icon appears at the top of the display.

Probe icon	
------------	---

- 3) Select a desired cooking mode. The probe can be used with **Hot Air**, **Top Bottom Heat** and **Roasting** modes.
- 4) Press **Temp.** to set the desired cooking temperature. Press **▲** or **▼** to raise or lower the numbers, then press **←** to save the settings.

You can also use the number pad icon to set the cooking temperature directly, then press **OK**.

- The default probe temperature is 65 °C, but can be changed to any temperature between 30 °C and 99 °C in step of 1 °C.

Number pad icon	
-----------------	---

- 5) If desired, press **Time** to set the cooking end time.

Press **▲** or **▼** to raise or lower the numbers, then press **←** to save the settings.

You can also use the number pad icon to set the cooking time directly, then press **OK**.

- 6) Press the **Start/Stop** button on the control panel. If a delayed start time has been set, the start time appears in the display.
- 7) When the set probe temperature is reached, the oven shuts off automatically.

Changing the Probe Temperature while Cooking

- 1) Press **Edit** in the display to bring up the Cook Settings screen.
- 2) Adjust the settings as desired.
- 3) Press the **Start/Stop** button on the control panel.

To Stop Cooking

Press the **Start/Stop** button on the control panel, then press **Stop** in the display.

NOTE

- Press the **Start/Stop** button on the control panel at any time to cancel a cooking operation.
- While the meat probe mode is running, EasyClean does not respond.

Recommended Probe Guide

Recommended Probe Placement Chart

Category	Examples of Food	Probe Placement
Ground Meat & Meat Mixtures	Meatloaf	Insert in the thickest part
	Meatballs	
Fresh Beef, Veal, Lamb	Steaks, Roasts, Chops	Insert in the thickest part, away from bone, fat and gristle
Poultry	Whole Chicken or Turkey	Insert in the thickest part of thigh, avoiding bone
	Poultry Breasts or Roasts	
	Duck, Goose, Pheasant	
	Stuffing (Alone or in Bird)	Insert in the thickest part of the dish
Leftovers & Casseroles	Leftovers	Insert in the thickest part of the dish
	Casseroles	
Seafood	Whole Fish	Insert in the thickest part of the fish
	Fish Fillet (Side of Fish)	
	Fish Steaks or Portions	

Recommended Probe Temperature Chart

Category	Examples of Food	Target Internal Temp.	Desired Doneness
Ground Meat & Meat Mixtures	Meatloaf	71 °C	-
	Meatballs	74 °C	
Fresh Beef, Veal, Lamb	Roasts	63 °C	Rare: 49 °C Medium rare: 52 °C Medium: 54 °C Medium well done: 57 °C Well done: 60 °C
Poultry	Whole Chicken or Turkey	74 °C	-
	Poultry Breasts or Roasts		
	Duck, Goose, Pheasant		
	Stuffing (Alone or in Bird)		

Category	Examples of Food	Target Internal Temp.	Desired Doneness
Leftovers & Casseroles	Leftovers	74 °C	-
	Casseroles		
Seafood	Whole Fish	63 °C	-
	Fish Fillet (Side of Fish)		
	Fish Steaks or Portions		

Grilling

For grilling, you have a choice of 2 different operating modes. Preheat for 5 minutes when grilling.

- For larger quantities of flat food for grilling, for top-baking in large tins. Choose power levels (**Low, Medium, High**), as suitable for the food being grilled.
- For smaller quantities of flat food for grilling, for top-baking in small tins. Choose power levels (**Low, Medium, High**), as suitable for the food being grilled.

WARNING

- Exposed parts of the oven can become hot during grilling. Keep children at a distance.

NOTE

- Close the door to set the Grill function. If the door is open, the Grill function cannot be set. If the door is open, the grill heater turns off. Once the door is closed, the grill heater turns back on automatically.

Setting the Grill Mode

- 1) Press **Manual Cook** in the **Main Menu** screen.
- 2) Select **Large Grill** or **Small Grill** in the cooking mode screen.
- 3) Select the desired temperature: **Low, Medium, or High**.
- 4) If desired, press **Time**.

And press **Cook Time** or **Cooking ends at.** to set the cook time or cooking end time. Press **▲** or **▼** to raise or lower the numbers, then press **←** to save the settings.

You can also use the number pad icon to set the cooking time directly, then press **OK**.

- 5) Press the **Start/Stop** button on the control panel.
- 6) Let the oven preheat for approximately 5 minutes before cooking the food.
- 7) If the cook time is set, the remaining time appears in the display. If a cooking end time is set, the start time appears in the display.
- 8) Press the **Start/Stop** button on the control panel to cancel at any time or when cooking is complete.

Changing the Grill Settings

- 1) Press **Edit** in the display to bring up the Cook Settings screen.
- 2) Adjust the settings using scroll function.
- 3) Press the **Start/Stop** button on the control panel.

To Stop Cooking

Press the **Start/Stop** button on the control panel, then press **Stop** in the display.

Recommended Grilling Guide

The grilling times are intended as approximate values only. The actual times may vary depending on the quality of the actual meat or fish. Grilling is particularly suitable for cooking flat pieces of meat and fish. Turn the grilled food over about half way through the cooking time.

Always count oven rack position from the bottom up.

Food	Rack Position	Large Grill Step 3 (min.)	
		1st Side	2nd Side
Rissoles	5	8-10	6-8
Beef or Veal Steaks	5	10-15	10-15
Beef Fillet (1 kg approx.)	4	10-12	10-12
Toast*1	4	2-4	2-4
Toast with Topping	4	6-8	-

*1 Wire grill or deep pan or baking tray.

NOTE

- Use rack position ④ or ⑤ for grilling flat pieces of meat.

Tips for Reducing Smoke

Due to the intense heat associated with grilling, it is normal to experience smoke during the cooking process. This smoke is a natural byproduct of searing and should not cause you to worry. If you are experiencing more smoke than you are comfortable with, use the following tips to reduce the amount of smoke in your oven.

- Always use a griller pan. Do not use saute pans or regular baking sheets for safety reasons.
- The griller pan should always be thoroughly cleaned and at room temperature at the beginning of cooking.
- ALWAYS run your cooktop ventilation system or vent hood during grilling.
- Keep the interior of your oven as clean as possible. Leftover debris from prior meals can burn or catch fire.
- Avoid fatty marinades and sugary glazes. Both of these will increase the amount of smoke you experience. If you would like to use a glaze, apply it at the very end of cooking.
- If you are experiencing significant smoke with any food item, consider:
 - Lowering the griller to the **Low** setting.
 - Lowering the rack position to cook the food farther away from the griller.
 - Using the **High** grill setting to achieve the level of searing you desire, and then either switching to the **Low** grill setting, or switching to the **Medium** grill setting.
- As a rule, fatter cuts of meat and fish will produce more smoke than leaner items.

- Adhere to the recommended grill settings and cooking guidelines in the chart on the following page whenever possible.

Air Fry

The **Air Fry** function is specially designed for oil-free frying.

NOTE

- No preheating is required when using the **Air Fry** mode.
- If cooking multiple batches, the later batches may take less time to cook.
- Wet batters and coatings will not crisp or set when using the **Air Fry** mode.

Setting Air Fry Mode

- 1) Press **Manual Cook** in the **Main Menu** screen.
- 2) Select **Air Fry** in the cooking mode screen.
- 3) Press **Temp.** to set the desired cooking temperature. Press **▲** or **▼** to raise or lower the numbers, then press **←** to save the settings.

You can also use the number pad icon to set the cooking temperature directly, then press **OK**.

- 4) If desired, press **Time**.
And press **Cook Time** or **Cooking ends at.** to set the cook time or cooking end time. Press **▲** or **▼** to raise or lower the numbers, then press **←** to save the settings.
You can also use the number pad icon to set the cooking time directly, then press **OK**.
- 5) Press the **Start/Stop** button on the control panel. The oven starts to preheat.
- 6) If the cook time is set, the remaining time appears in the display. If a cooking end time is set, the start time appears in the display.
- 7) A chime sounds at the end of the set cook time and a notification appears in the display. Open the oven door and remove the food.

To Stop Cooking

- 1) Press the **Start/Stop** button on the control panel, then press **Stop** in the display.

Tips for Air Fry

- For best results, cook food on a single rack placed in positions suggested in the chart in this manual.
- Spread the food out evenly in a single layer.
- Use either the provided air fry tray or a dark baking tray with no sides or short sides that does not cover the entire rack. This allows for better air circulation.
- If desired, spray the baking tray or air fry tray with a pan spray. Use an oil that can be heated to a high temperature before smoking, such as avocado, grapeseed, peanut or sunflower oil.
- Place a foil-lined baking tray on a rack in position 1 to catch the oil falling from the food. For high-fat foods like chicken wings, add a few sheets of parchment paper to absorb the fat.
- Check food often and shake it or turn it over for crisper results.
- Prepared frozen foods may cook faster with the Air Fry mode than stated on the package. Reduce the cooking time by about 20 percent, check food early, and adjust cooking time as needed.
- Use a food thermometer to make sure food has reached a safe temperature for consumption. Eating undercooked meats can increase your risk of food-borne illness.
- For the crispiest results, dredge fresh chicken wings or tenders in seasoned flour. Use 1/3 cup flour for 2 pounds of chicken.

Recommendations When Air Frying High-Fat Foods

Foods high in fat will smoke when using the Air Fry mode. For best results, follow these recommendations when air frying foods that are high in fat, such as chicken wings, turkey legs, lamb chops, ribs, duck breasts, or some plant-based proteins.

CAUTION

- Never cover slots, holes, or passages in the oven bottom or cover entire racks with materials such as aluminum foil. Doing so blocks airflow through the oven and can result in carbon monoxide poisoning. Aluminum foil can also trap heat, causing a fire hazard or poor oven performance.
- Open a window or sliding glass door, if possible, to make sure the kitchen is well-ventilated.
- Keep the oven free from grease buildup. Wipe down the interior of the oven before and after air frying (once the oven has cooled).
- Run oven cleaning cycles (EasyClean) regularly, depending on how often and what types of food you Air Fry.
- Avoid opening the oven door more than necessary to help maintain the oven temperature, prevent heat loss, and save energy.
- Air-frying fresh chicken pieces such as wings or drumsticks with the skin left on can produce smoke as the fat renders at high temperatures. If the smoke is excessive, use the Roast mode instead of Air Fry.

Recommended Air Frying Guide

Cooking on a baking tray

- Arrange food evenly in a single layer.
- Place the baking tray on rack position ③.
- Flip food over during cooking to avoid burning it.

POTATOES-Frozen				
Menu	Quantity (kg)	Temp. (°C)	Rack Position	Time (minute)
Frozen french fries (Shoestring)	0.4	200	3	15-25
Frozen french fries (Crinkle cut, 10x10 mm)	0.8	200	3	20-30
Frozen sweet potato fries	0.6	200	3	17-27
Frozen tater tots	1.0	220	3	17-27
Frozen hash browns	1.0	220	3	15-25

POTATOES-Fresh/Homemade				
Menu	Quantity (kg)	Temp. (°C)	Rack Position	Time (minute)
Homemade potato wedges	1.3	230	3	25-35

CHICKEN-Frozen				
Menu	Quantity (kg)	Temp. (°C)	Rack Position	Time (minute)
Frozen chicken nuggets, Crispy	0.6	200	3	15-25
Frozen chicken strips	0.8	210	3	20-30

CHICKEN-Fresh, Skin on				
Menu	Quantity (kg)	Temp. (°C)	Rack Position	Time (minute)
Fresh chicken wings	1.2	230	3	27-37
Fresh chicken drumsticks	2.0	230	3	35-45
Thighs	1.2	230	3	27-37
Breasts	1.2	230	3	27-37

OTHER				
Menu	Quantity (kg)	Temp. (°C)	Rack Position	Time (minute)
Frozen onion rings, Breaded	0.5	200	3	15-25
Frozen spring rolls (20 g each)	1.2	210	3	20-30
Frozen coconut shrimps	0.7	200	3	20-30
Fresh scallops on the half shell	1.0	210	3	15-25
Fresh shrimps	1.0	200	3	20-30
Mixed vegetables	1.0	220	3	17-27

Cooking on an air fry tray

- Arrange food evenly in a single layer.
- Put a foil-lined baking pan on rack position ② to catch drips. If needed, add parchment paper to absorb oil and reduce smoking.
- Flip food over during cooking to avoid burning it.

POTATOES-Frozen				
Menu	Quantity (kg)	Temp. (°C)	Rack Position	Time (minute)
Frozen french fries (Shoestring)	0.4	200	3	15-25
Frozen french fries (Crinkle cut, 10x10 mm)	0.8	200	3	20-30
Frozen sweet potato fries	0.6	200	3	17-27
Frozen tater tots	1.0	220	3	17-27
Frozen hash browns	1.0	220	3	15-25

POTATOES-Fresh/Homemade				
Menu	Quantity (kg)	Temp. (°C)	Rack Position	Time (minute)
Homemade french fries (10x10 mm)	0.6	220	3	20-30

54 OPERATION

POTATOES-Fresh/Homemade				
Menu	Quantity (kg)	Temp. (°C)	Rack Position	Time (minute)
Homemade potato wedges	1.3	230	3	25-35

CHICKEN-Frozen				
Menu	Quantity (kg)	Temp. (°C)	Rack Position	Time (minute)
Frozen chicken nuggets, Crispy	0.6	200	3	15-25
Frozen chicken strips	0.8	210	3	20-30
Frozen hot wings, Bone-in	1.2	200	3	30-40

CHICKEN-Fresh, Skin on				
Menu	Quantity (kg)	Temp. (°C)	Rack Position	Time (minute)
Fresh chicken wings	1.2	230	3	27-37
Fresh chicken drumsticks	2.0	230	3	35-45
Thighs	1.2	230	3	27-37
Breasts	1.2	230	3	27-37

OTHER				
Menu	Quantity (kg)	Temp. (°C)	Rack Position	Time (minute)
Frozen onion rings, Breaded	0.5	200	3	15-25
Frozen spring rolls (20 g each)	1.2	210	3	20-30
Frozen coconut shrimps	0.7	200	3	20-30
Fresh scallops on the half shell	1.0	210	3	15-25

Air Sous-Vide (Model WSED7665B)

This feature is only available on some models.

Air Sous-Vide cooking uses air to cook foods "low and slow." Use it to cook meat, fish, seafood, poultry or vegetables. Food must be vacuum packed in pouches.

It is not necessary to preheat the oven when using **Air Sous-Vide**.

Refer to the cooking guide for recommended **Air Sous-Vide** settings.

Setting Air Sous-Vide Mode

- 1) Place the wire grill and place the sealed food bag on it.
- 2) Press **Manual Cook** in the **Main Menu** screen.
- 3) Select **Air Sous-Vide** in the cooking mode screen.
- 4) Press **Temp.** to set the desired cooking temperature. Press **▲** or **▼** to raise or lower the numbers, then press **←** to save the settings.

You can also use the number pad icon to set the cooking temperature directly, then press **OK**.

- 5) If desired, press **Time**.
And press **Cook Time** or **Cooking ends at.** to set the cook time or cooking end time. Press **▲** or **▼** to raise or lower the numbers, then press **←** to save the settings.
You can also use the number pad icon to set the cooking time directly, then press **OK**.
- 6) Press the **Start/Stop** button on the control panel. The oven starts to preheat.
- 7) If the cook time is set, the remaining time appears in the display. If a cooking end time is set, the start time appears in the display.
- 8) A chime sounds at the end of the set cook time and a notification appears in the display. Open the oven door and remove the food.

To Stop Cooking

- 1) Press the **Start/Stop** button on the control panel, then press **Stop** in the display.

Benefits of Air Sous-Vide

The lower temperatures and long cooking times used in **Air Sous-Vide** cooking provide many benefits.

- **Healthier**
Compared to other cooking methods, Air Sous-Vide retains most of the original nutrients in food.
- **Safe and Convenient**
The long cooking times used in Air Sous-Vide cooking allow food to be pasteurized. Because food is vacuum packed before cooking, the unopened pouches can be quickly chilled then easily stored after cooking.
- **Crisp and Moist Results**
The fine temperature control of Air Sous-Vide cooking is an excellent way to achieve the perfect texture when cooking meat and poultry. The low temperatures used retain more of the moisture in food than conventional cooking methods. After cooking, a final sear in a frying pan adds the perfect crisp finish.

Recommended Air Sous-Vide Guide

The size, weight, thickness, starting temperature, and your personal preferences will affect operating times. This guide is only for reference. Adjust cook time according to your preference.

- Rack: Rack Position

Food	Quantity (each)	Temp. (°C)	Rack	Time (min.)		
				Min	Target	Max
Beef Steak (Medium rare)	2.5 cm thick 0.3~0.5 kg	58	2	-	150	180
Chicken, Breasts	0.1~0.2 kg	67	2	-	120	180
Salmon	2.5 cm thick 0.1~0.2 kg	60	2	-	120	150
Asparagus	15~20 g	85	2	20	30	45

- Cook 30 minutes or 1 hour more if you use meats thicker than 2.5 cm.
- If you use larger cuts of meat, cut to match the recommended weight. Be careful not to put pouches of meat too close to each other.

Defrosting

Use the Defrost  operating mode to defrost food.

Defrosting Dishes

- Remove the dish from its packaging, put it on a plate and place the plate on the wire grill.
- Do not cover the dish with a plate or bowl, as this can considerably extend the defrosting time.
- Do not use the liquid produced during defrosting for cooking the dish to avoid the risk of salmonella. Ensure that the liquid produced during defrosting is free to run off the food onto the plate or a baking pan if using the wire grill.

Oven Rack Position

For defrosting, use the wire grill on rack position ① or ② for larger dishes.

Setting Defrosting Mode

- 1) Press **Manual Cook** in the **Main Menu** screen.
- 2) Select **Defrost** in the cooking mode screen.

- 3) If desired, press **Time**.

And press **Cook Time** or **Cooking ends at**. to set the cook time or cooking end time. Press **▲** or **▼** to raise or lower the numbers, then press **←** to save the settings.

You can also use the number pad icon to set the cooking time directly, then press **OK**.

- 4) Press the **Start/Stop** button on the control panel. The oven starts to preheat.
- 5) The remaining time appears in the display. If a cooking end time is set, the start time appears in the display.
- 6) A chime sounds at the end of the set cook time and a notification appears in the display. Open the oven door and remove the food.

To Stop Cooking

- 1) Press the **Start/Stop** button on the control panel, then press **Stop** in the display.

Recommended Defrosting Guide

- Rack: Rack Position

Food	Weight (kg)	Time (minute)	Instructions
Chicken	1.0	100-140	Use the wire grille with the deep pan (or baking tray). Turn the chicken after half of the time.
Meat	1.0	100-140	Turn the meat after half of the time or cover with tin foil.
	0.5	90-120	
Trout	0.15	25-35	Do not cover.
Strawberries	0.3	20-30	Do not cover.

Steam Function

Steam cooking uses the moist heat of steam to cook food. This is an ideal cooking method for delicate food items such as seafood, which can lose nutrients when boiled.

Steam Cook modes may vary depending on the appliance. Refer to the below table to see available cooking modes.

Model	Steam Cooking Modes
WSED7667M	Steam, Steam-Hot Air, Steam-Roasting, Steam-Baking, Steam-Regenerating, Sous-Vide
WSED7665B	Steam-Hot Air, Steam-Roasting, Steam-Baking, Steam-Regenerating

⚠ CAUTION

- Take care when opening the oven door during or after steam cooking. Hot steam can cause scalding.
- After any steam cooking cycle, the drying function will run automatically. It is normal to hear the steam pump running during the drying function.

Using the Water Tank

The water tank is located behind the control panel.

- 1) Press the **Water Tank** button on the control panel.

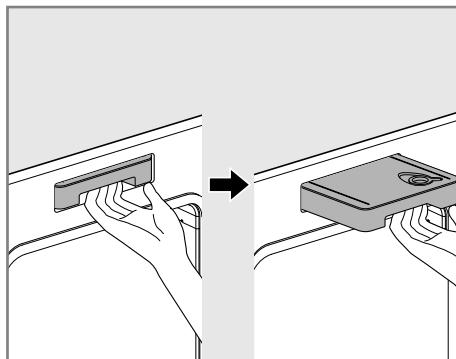

- For Model WSED7667M, the control panel automatically fully opens.
 - For Model WSED7665B, the control panel opens a little. Manually open the control panel fully.
- 2) Remove the tank and place it on a flat surface.
 - 3) Remove the tank cover or flip open the fill lid at the front of the tank cover.
 - 4) Fill the tank to the **Max** line. Use softened, filtered water, if possible. Hard water may clog the steam generator more quickly with scale buildup.

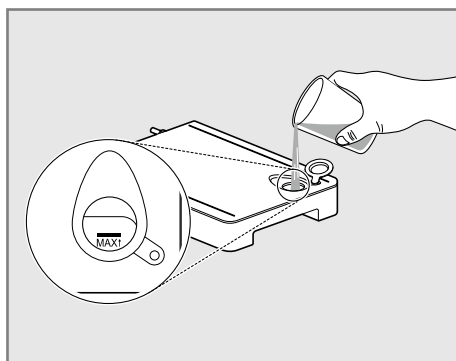

- 5) Assemble the tank cover and the fill lid.

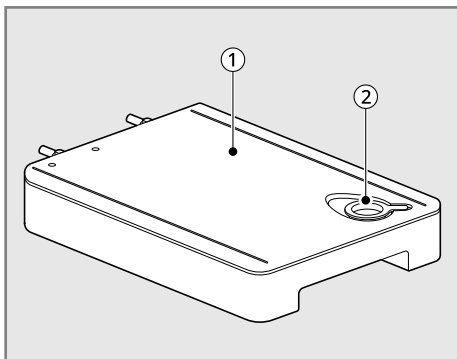

①	Tank cover
②	Fill lid

⚠ CAUTION

- Make sure the tank cover and fill lid are closed before putting the tank in the oven.
- Use potable water only.
- Do not fill the water tank with any fluid or mixture other than water.
- Do not fill the tank with hot water.
- Fill the water tank up to the line indicated on the front.
- Do not tilt the water tank while it is full.
- Discard any remaining water and clean the water tank after cooking.
- Use the water tank only for its intended purpose of providing water for steam cooking.
- Monitor the water level in the tank and refill as needed for steam cooking. Use oven mitts to avoid burns when handling the hot tank.

- 6) Carefully insert the water tank into correct position in the control panel, making sure to keep the tank level while carrying it. If the tank is not kept level, water will drain out of the tubes in the back.
- 7) Close the control panel.

Steam Cook

Setting Steam-Hot Air

The **Steam-Hot Air** mode heats food gradually, using heating element in the back wall and moist steam heat. The oven can be programmed to cook at any temperature from 30 °C to 250 °C. Preset temperature options start at 160 °C.

- 1) Press **Steam Cook** in the **Main Menu** screen.
- 2) Press **Steam-Hot Air**.
- 3) Press **Steam Level** and select the desired **Steam Level High, Medium or Low**.
 - The **Steam Level** defaults to **High** unless changed by the user.
- 4) Press **Temp.** to set the desired cooking temperature. Press **▲** or **▼** to raise or lower the numbers, then press **←** to save the settings.

You can also use the number pad icon to set the cooking temperature directly, then press **OK**.

- 5) If desired, press **Time**.

And press **Cook Time** or **Cooking ends at.** to set the cook time or cooking end time. Press **▲** or **▼** to raise or lower the numbers, then press **←** to save the settings.

You can also use the number pad icon to set the cooking time directly, then press **OK**.

- 6) Press the **Start/Stop** button on the control panel.
- 7) Once cooking is finished, allow oven to cool completely, then wipe up any water on the oven interior.

To Stop Cooking

- 1) Press the **Start/Stop** button on the control panel, then press **Stop** in the display.

Setting Steam-Roasting

The **Steam-Roasting** mode is designed to quickly roast poultry. The combination of intense heat from the upper heating elements and steam results in crispier food and shorter cooking times. The Steam-Roasting mode is especially good for medium sized poultry. The oven can be programmed to cook at any temperature from 30

°C to 250 °C. Preset temperature options start at 190°C.

- 1) Press **Steam Cook** in the **Main Menu** screen.
- 2) Press **Steam-Roasting**.
- 3) Press **Temp.** to set the desired cooking temperature. Press **▲** or **▼** to raise or lower the numbers, then press **←** to save the settings.

You can also use the number pad icon to set the cooking temperature directly, then press **OK**.

- 4) If desired, press **Time**.

And press **Cook Time** or **Cooking ends at.** to set the cook time or cooking end time. Press **▲** or **▼** to raise or lower the numbers, then press **←** to save the settings.

You can also use the number pad icon to set the cooking time directly, then press **OK**.

- 5) Press the **Start/Stop** button on the control panel.
- 6) Once cooking is finished, allow oven to cool completely, then wipe up any water on the oven interior.

NOTE

- **Steam-Roasting** is designed to reduce the cooking time. There is no need for preheating.
-

To Stop Cooking

- 1) Press the **Start/Stop** button on the control panel, then press **Stop** in the display.

Setting Steam-Baking

The **Steam-Baking** mode heats food gradually, using both the top & bottom oven heating elements and moist steam heat. The oven can be programmed to cook at any temperature from 30 °C to 250 °C. Preset temperature options start at 180°C.

- 1) Press **Steam Cook** in the **Main Menu** screen.
- 2) Press **Steam-Baking**.
- 3) Press **Steam Level** and select the desired **Steam Level High, Medium** or **Low**.

- The **Steam Level** defaults to **High** unless changed by the user.

- 4) Press **Temp.** to set the desired cooking temperature. Press **▲** or **▼** to raise or lower the numbers, then press **←** to save the settings.

You can also use the number pad icon to set the cooking temperature directly, then press **OK**.

- 5) If desired, press **Time**.

And press **Cook Time** or **Cooking ends at.** to set the cook time or cooking end time. Press **▲** or **▼** to raise or lower the numbers, then press **←** to save the settings.

You can also use the number pad icon to set the cooking time directly, then press **OK**.

- 6) Press the **Start/Stop** button on the control panel.
- 7) Once cooking is finished, allow oven to cool completely, then wipe up any water on the oven interior.

To Stop Cooking

- 1) Press the **Start/Stop** button on the control panel, then press **Stop** in the display.

Setting Steam-Regenerating

The **Steam-Regenerating** mode heats food gently and makes the pastry crispy. Steam ensures that the food does not dry out. The oven can be programmed to cook at any temperature from 80 °C to 180 °C. Preset temperature options start at 120°C.

- 1) Press **Steam Cook** in the **Main Menu** screen.
- 2) Press **Steam-Regenerating**.
- 3) Press **Temp.** to set the desired cooking temperature. Press **▲** or **▼** to raise or lower the numbers, then press **←** to save the settings.

You can also use the number pad icon to set the cooking temperature directly, then press **OK**.

- 4) If desired, press **Time**.

And press **Cook Time** or **Cooking ends at.** to set the cook time or cooking end time. Press

▲ or ▼ to raise or lower the numbers, then press ← to save the settings.

You can also use the number pad icon to set the cooking time directly, then press **OK**.

- 5) Press the **Start/Stop** button on the control panel.
- 6) Once cooking is finished, allow oven to cool completely, then wipe up any water on the oven interior.

To Stop Cooking

- 1) Press the **Start/Stop** button on the control panel, then press **Stop** in the display.

Setting Steam (Model WSED7667M)

The **Steam** mode cooks food without the assistance of the oven heating elements, using only the moist heat produced by steam. The available temperature range is 80 °C to 99 °C. Make sure to empty the water tank after use.

- 1) Press **Steam Cook** in the **Main Menu** screen.
- 2) Press **Steam**.
- 3) Press **Temp.** to set the desired cooking temperature. Press ▲ or ▼ to raise or lower the numbers, then press ← to save the settings.

You can also use the number pad icon to set the cooking temperature directly, then press **OK**.

- 4) If desired, press **Time**.
And press **Cook Time** or **Cooking ends at.** to set the cook time or cooking end time. Press ▲ or ▼ to raise or lower the numbers, then press ← to save the settings.

You can also use the number pad icon to set the cooking time directly, then press **OK**.

- 5) Press the **Start/Stop** button on the control panel.
- 6) Once cooking is finished, allow oven to cool completely, then wipe up any water on the oven interior.

To Stop Cooking

- 1) Press the **Start/Stop** button on the control panel, then press **Stop** in the display.

NOTE

- Once steam cooking is started, an indicator on the display shows the status of the steam function.
- Make sure the water tank is filled with water before starting the steam cooking. If the water in the tank runs out during cooking, a chime sounds and a popup appears in the display. The oven continues to cook without steam.
- Remember to drain the water tank after use.
- When the temperature rises in the oven, steam may not be visible.
- It is normal to hear the sound of boiling water from the steam generator while running the steam functions.
- If mineral deposits remain on the oven bottom after steam mode, use a cloth or sponge soaked in vinegar or a weak citric acid solution to remove them before using the steam mode again. See the Maintenance section under Descaling for more info. To remove stubborn hard water scale, use the Descaling function.
- Wipe away excess water left over after cooling.
- To avoid damage and extend product life, descale the steam feeder after every 8 hours of use, or more often if needed.
- If the descaling reminder appears, press **OK** to run the Descaling function.
- After the steam mode is used for 8 hours, a reminder to descale the product appears in the display the next time the steam mode is selected. You will not be able to use the steam mode until the Descaling function is run. To avoid this delay, run the Descaling function after every 2-3 uses of the steam mode.

Sous-Vide (Model WSED7667M)

Sous-Vide cooking uses steam to cook foods "low and slow." Use it to cook meat, fish, seafood, poultry or vegetables. Food must be vacuum packed in pouches.

It is not necessary to preheat the oven when using Sous-Vide.

Refer to the cooking guide for recommended Sous-Vide settings.

Preset temperature options start at 60 °C.

Benefits of Sous-Vide

The lower temperatures and long cooking times used in Sous-Vide cooking provide many benefits.

- **Healthier**

Compared to other cooking methods, Sous-Vide retains most of the original nutrients in food.

- **Safe and Convenient**

The long cooking times used in Sous-Vide cooking allow food to be pasteurized. Because food is vacuum packed before cooking, the unopened pouches can be quickly chilled then easily stored after cooking.

- **Crisp and Moist Results**

The fine temperature control of Sous-Vide cooking is an excellent way to achieve the perfect texture when cooking meat and poultry. The low temperatures used retain more of the moisture in food than conventional cooking methods. After cooking, a final sear in a frying pan adds the perfect crisp finish.

Setting Sous-Vide Mode

- 1) Fill the tank to the **Max** line. Use softened, filtered water, if possible. Hard water may clog the steam generator more quickly with scale buildup.
- 2) Place the wire grill on rack position ③ and place the sealed food bag on it.
- 3) Press **Steam Cook** in the **Main Menu** screen.
- 4) Press **Sous-Vide**.
- 5) Press **Temp.** to set the desired cooking temperature. Press **▲** or **▼** to raise or lower the numbers, then press **←** to save the settings.

You can also use the number pad icon to set the cooking temperature directly, then press **OK**.

- 6) If desired, press **Time**.

And press **Cook Time** or **Cooking ends at.** to set the cook time or cooking end time. Press **▲** or **▼** to raise or lower the numbers, then press **←** to save the settings.

You can also use the number pad icon to set the cooking time directly, then press **OK**.

- 7) Press the **Start/Stop** button on the control panel.
- 8) Once cooking is finished, allow the oven to cool completely. Then wipe up any water left on the oven interior.

Changing the Sous-Vide Settings

- 1) Press **Edit** in the display to bring up the Cook Settings screen.
- 2) Adjust the settings using scroll function.
- 3) Press the **Start/Stop** button on the control panel.

To Stop Cooking

- 1) Press the **Start/Stop** button on the control panel, then press **Stop** in the display

Recommended Sous-Vide Guide

The size, weight, thickness, starting temperature, and your personal preferences will affect operating times. This guide is only for reference. Adjust cook time according to your preference.

- Rack: Rack Position

Food	Quantity (each)	Temp. (°C)	Rack	Time (min.)		
				Min	Target	Max
Beef Steak	2.5 cm thick 0.3~0.5 kg	58	2	-	150	180
Chicken, Breasts	0.1~0.2 kg	67	2	-	120	180
Salmon	2.5 cm thick 0.1~0.2 kg	60	2	-	120	150
Asparagus	15~20 g	85	2	20	30	45

Recipe Cook

The **Recipe Cook** function provides guidance for cooking foods or dishes that may be unfamiliar. It contains preset programs for cooking many popular food items, with information on recommended preheating, accessories, and rack position for optimal results. The remaining time is automatically adjusted and appears in the display.

Setting Recipe Cook Mode

- 1) Press **Recipe Cook** in the **Main Menu** screen.
- 2) Press a category to filter the options.
- 3) Scroll through or tap the letters to find and select an item.
- 4) Press **Weight** to set the weight of the food. Press **▲** or **▼** to increase or decrease the weight, then press **←**.
 - The Weight feature can be used with some menu. Refer to the Recipe Cook Guide for more information.

- 5) Press **Info.** to see the recommended recipe.
 - The recommendations may differ depending on the category and weight of your food.
 - Follow the recommendations in the display regarding accessories and rack position.
- 6) Press **←**.
- 7) Press the **Start/Stop** button on the display.

Recipe Cook Guide

- Preheat oven first for most items.
- Preheat for 5 minutes when grilling.

NOTE

- When cooking thin cuts of meat, insert the probe into the thickest part of the meat. If the probe is inserted incorrectly, the oven could turn off too soon. See the Probe section for instructions.

Recipe Cook Guide

Poultry					
Menu	Weight	Step	Food Temp.	Rack Position	Instructions
Chicken , Legs *1*3	0.6-1.8 kg	0.2 kg	Refrigerated	3	Brush chicken legs with oil or melted butter, season as desired. Place chicken legs on the wire grill. Put into the oven. To catch drippings or fat from food, place the deep pan (or baking tray) below of the wire grill. When oven beeps, turn food over. After cooking, allow to rest covered with foil for 3 minutes. Use generated juice for gravy or sauce.
	Default 1.2 kg				
Chicken , Breasts *11*12	0.2-1.0 kg	0.2 kg	Refrigerated	3	Model WSED7667M Prepare chicken breast (about 200 g each). Place chicken breast in the perforated pan on the wire grill. Put into the oven. To catch drippings or fat from food, place the deep pan (or baking tray) below of the wire grill.
	Default 0.6 kg				

Poultry					
Menu	Weight	Step	Food Temp.	Rack Position	Instructions
Chicken, Whole *1*3	1.0-2.0 kg	0.2 kg	Refrigerated	2	Brush chicken with oil or melted butter, season as desired. Wrap thin part of the legs in foil, place chicken on the wire grill. Put into the oven. To catch drippings or fat from food, fill a big cup of water into the deep pan (or baking tray) and place below of the wire grill. When oven beeps, turn food over. After cooking, allow to rest covered with foil for 3 minutes. Use generated juice for gravy or sauce.
	Default 1.4 kg				
Duck, Breasts *11*12	0.2-1.0 kg	0.2 kg	Refrigerated	3	Model WSED7667M Prepare duck breast (about 200 g each). Place duck breast in the perforated tray on the wire grill. Put into the oven. To catch drippings or fat from food, place the deep pan (or baking tray) below of the wire grill.
	Default 0.6 kg				
Duck, Whole *1*3	1.7-2.5 kg	0.2 kg	Refrigerated	2	Brush duck with oil or melted butter, season as desired. Wrap thin part of the legs in foil, place duck on the wire grill. Put into the oven. To catch drippings or fat from food, fill a big cup of water into the deep pan (or baking tray) and place below of the wire grill. When oven beeps, turn food over. After cooking, allow to rest covered with foil for 3 minutes. Use generated juice for gravy or sauce.
	Default 2.1 kg				
Turkey, Whole *1*3	3.2-4.7 kg	0.5 kg	Refrigerated	1	Brush turkey with oil or melted butter, season as desired. Wrap thin part of the legs in foil, place turkey on the wire grill. Put into the oven. To catch drippings or fat from food, fill a big cup of water into the deep pan (or baking tray) and place below of the wire grill. When oven beeps, turn food over. After cooking, allow to rest covered with foil for 3 minutes. Use generated juice for gravy or sauce.
	Default 4.2 kg				

Beef					
Menu	Weight	Step	Food Temp.	Rack Position	Instructions
Kebab *3	0.5 Kg	0.5 kg	Room	4	<p>Ingredients 1.2 kg ground meat (Mix beef and veal at a ratio of 3 to 1), 2 eggs, ½ tsp minced garlic, 1 small onion chopped, ½ cup breadcrumbs, 1 tbsp. salt, ½ tsp pepper, ¼ cup finely chopped fresh mint, ¼ cup olive oil</p> <p>Method Combine the ground meat, eggs, garlic onion, breadcrumbs, salt, pepper, mint, and olive oil into a large bowl and mix the ingredients. Roll into balls of 50 g each and pierce each ball through with bamboo skewers and spread into long kebabs, about 3 inch or longer on the skewer. Position the skewers onto a wire grill. Put into the oven and place the deep pan(or baking tray) below of the wire grill. After cooking, let cool kebabs before serving.</p>
	Default 1.5 kg				
Kafta *12	0.4 Kg	0.4 kg	Room	4	<p>Ingredients 1 kg ground beef with some fat(15 %), 1 ½ tsp ground cardamom, 2 ½ tsp ground allspice, 2 tsp salt, 1 tsp black pepper, 1 packed cup (25 g) chopped parsley, 2-3 hot green chile peppers, 4-5 cloves garlic, 1 medium onion</p> <p>Method Place the ground meat in a large bowl and add the spices. Run the parsley, chiles, garlic and onion together through a meat grinder or pulse them gently, adding one ingredient at a time, in a food processor, beginning with the parsley and ending with the onions. Combine with the ground meat. Mould a small quantity of the meat mixture around skewers, forming elongated, thin kebabs. Position the skewers onto a wire grill. Put into the oven and place the deep pan(or baking tray) below of the wire grill.</p>
	Default 1.2 kg				

Beef					
Menu	Weight	Step	Food Temp.	Rack Position	Instructions
Goulash *3	1 serving	-	Room	3	<p>Ingredients</p> <p>1 tbsp. olive oil, 1 small onion, 680 g lean ground beef, 1 tsp allspice, ½ tsp ground black pepper, 1 tsp salt, ¼ tsp ground cinnamon, ¼ tsp ground ginger, 1 tbsp. tomato paste</p> <p>A packet (45 g) phyllo dough thawed, ½ cup light tasting olive oil, ¼ cup ghee or butter melted, 1 cup milk, 1 large egg, salt and pepper</p> <p>Method</p> <p>Add the olive oil in a large non-stick saute pan and heat, then saute onion for 2-3 minutes until tender. Add the ground beef, breaking it apart then add all the other ingredients. Cook until browned, set aside. Melt ghee in a small sauce pan or in the microwave. Mix in olive oil. Brush or spray an oven safe dish with the oil, take 2-3 sheets of phyllo dough and lay them flat on dish, then brush with oil mixture. Continue layering the phyllo dough 2-3 sheets at a time and brushing them until done with half the package. Add the minced meat mixture and spread evenly. Continue layering and brushing the remaining phyllo sheets until done with the package. Cut into squares or diamond shape. In a measuring cup, beat the egg and add the milk, sprinkle some salt and pepper, then carefully pour into the dish, tilt the dish in all directions so the milk mixture will spread evenly. Put into the oven.</p>
Roast Beef *1*3	1.0-2.5 kg	0.5 kg	Refrigerated	2	Brush beef with oil or melted butter, season as desired. Place beef on the wire grill. Put into the oven. To catch drippings or fat from food, fill a big cup of water into the deep pan (or baking tray) and place below of the wire grill. When oven beeps, turn food over. After cooking, allow to rest covered with foil for 10 minutes. Use generated juice for gravy or sauce.
	Default 1.5 kg				

Beef					
Menu	Weight	Step	Food Temp.	Rack Position	Instructions
Roast Veal *1*3	1.0-2.0 kg	0.5 kg	Refrigerated	2	Brush veal (back of veal) with oil or melted butter, season as desired. Place veal on the wire grill. Put into the oven. To catch drippings or fat from food, fill a big cup of water into the deep pan (or baking tray) and place below of the wire grill. When oven beeps, turn food over. After cooking, allow to rest covered with foil for 10 minutes. Use generated juice for gravy or sauce.
	Default 1.5 kg				
Fillet of Beef *1*3	0.4-1.2 kg	0.2 kg	Refrigerated	4	Brush fillet of beef with oil or melted butter, season as desired. Place beef on the wire grill. Put into the oven. To catch drippings or fat from food, place the deep pan (or baking tray) below of the wire grill. When oven beeps, turn food over. After cooking, allow to rest covered with foil for 5 minutes. Use generated juice for gravy or sauce.
	Default 0.8 kg				
Beef Bourguignon *4*7*13	1 serving	-	Room	2	<p>Ingredients 1 kg beef, 50 g oil, 750 ml red wine, 200-300 ml broth, 5 onions, 5 cloves of garlic, 200 g mushrooms, 100 g tomato puree, 1 tsp sweet paprika, 5 bay leaves, salt, pepper</p> <p>Method Cut the beef into 1 cm cubes. Put the oil in a roasting pot, add the meat and roast it on a hob. Deglaze the roasted meat with red wine and broth. Peel and dice the onions and garlic. Clean the mushrooms and slice. Add the ingredients, season and mix it, cover with a lid. Place roasting pot on the wire grill. Put into the oven. After cooking, allow to rest covered with foil for 10 minutes.</p>

Lamb					
Menu	Weight	Step	Food Temp.	Rack Position	Instructions
Leg of Lamb *1*3	1.0-2.0 kg	0.5 kg	Refrigerated	2	Brush leg of lamb with oil or melted butter, season as desired. Place lamb on the wire grill. Put into the oven. To catch drippings or fat from food, fill a big cup of water into the deep pan (or baking tray) and place below of the wire grill. When oven beeps, turn food over. After cooking, allow to rest covered with foil for 10 minutes. Use generated juice for gravy or sauce.
	Default 1.5 kg				
Lamb Chops *1*3	0.4-1.2 kg	0.2 kg	Refrigerated	4	Brush lamb chops with oil or melted butter, season as desired. Place lamb chops on the wire grill. Put into the oven. To catch drippings or fat from food, place the deep pan (or baking tray) below of the wire grill. When oven beeps, turn food over. After cooking, allow to rest covered with foil for 3 minutes. Use generated juice for gravy or sauce.
	Default 0.8 kg				

Fish					
Menu	Weight	Step	Food Temp.	Rack Position	Instructions
Salmon *1*3	0.4-1.2 kg	0.2 kg	Refrigerated	4	Choose salmon steaks of 200 g weight and 2.5 cm thickness each. Brush salmon with oil or melted butter, season as desired. Place salmon on the wire grill. Put into the oven. To catch drippings or fat from food, place the deep pan (or baking tray) below of the wire grill. When oven beeps, turn food over. After cooking, allow to rest covered with foil for 3 minutes. Use generated juice for gravy or sauce.
	Default 0.8 kg				
Trout *1*3	0.4-1.2 kg	0.2kg	Refrigerated	4	Choose trout of 200 g weight each. Brush trout with oil or melted butter, season as desired. Place trout on the wire grill. Put into the oven. To catch drippings or fat from food, place the deep pan (or baking tray) below of the wire grill. When oven beeps, turn food over. After cooking, allow to rest covered with foil for 3 minutes. Use generated juice for gravy or sauce.
	Default 0.8 kg				

Fish					
Menu	Weight	Step	Food Temp.	Rack Position	Instructions
Tuna *1*3	0.4-1.2 kg	0.2 kg	Refrigerated	4	Choose tuna fish steaks of 200 g weight and 2.5 cm thickness each. Brush tuna with oil or melted butter, season as desired. Place tuna on the wire grill. Put into the oven. To catch drippings or fat from food, place the deep pan (or baking tray) below of the wire grill. When oven beeps, turn food over. After cooking, allow to rest covered with foil for 3 minutes. Use generated juice for gravy or sauce.
	Default 0.8 kg				
Shrimps *1*3	0.4-0.8 kg	0.2 kg	Refrigerated	4	Brush shrimp with oil or melted butter, season as desired. Place shrimp on the deep pan. Put into the oven. When oven beeps, turn food over. After cooking, allow to rest covered with foil for 5 minutes. Use generated juice for gravy or sauce.
	Default 0.6 kg				
Scallops *3	0.4-0.8 kg	0.2 kg	Refrigerated	4	Put sherry with scallops. Place scallops on the deep pan. Brush melted butter over scallops. Cover with breadcrumbs. Add melted butter over breadcrumbs. Put into the oven. After cooking, allow to rest covered with foil for 5 minutes. Use generated juice for gravy or sauce.
	Default 0.6 kg				

Vegetables					
Menu	Weight	Step	Food Temp.	Rack Position	Instructions
Broccoli *11*12	0.2-0.6 kg	0.2 kg	Refrigerated	3	Model WSED7667M Cut broccoli into even size pieces (about 15 g for each). Wash the broccoli. Place broccoli in the perforated tray on the wire grill. Put into the oven. To catch drippings from food, place the deep pan(or baking tray) below of the wire grill.
	Default 0.4 kg				
Green Beans *11*12	0.1-0.3 kg	0.1 kg	Refrigerated	3	Model WSED7667M Wash green beans. Place green beans in the perforated tray on the wire grill. Put into the oven. To catch drippings from food, place the deep pan (or baking tray) below of the wire grill.
	Default 0.2 kg				

Vegetables					
Menu	Weight	Step	Food Temp.	Rack Position	Instructions
Asparagus *11*12	0.2-0.4 kg	0.1 kg	Refrigerated	3	Model WSED7667M Wash asparagus. Place asparagus in the perforated tray on the wire grill. Put into the oven. To catch drippings from food, place the deep pan (or baking tray) below of the wire grill.
	Default 0.3 kg				
Spinach *11*12	0.1-0.3 kg	0.1 kg	Refrigerated	3	Model WSED7667M Wash spinach. Place spinach in the perforated tray on the wire grill. Put into the oven. To catch drippings from food, place the deep pan (or baking tray) below of the wire grill.
	Default 0.2 kg				
Carrot *11*12	0.2-0.6 kg	0.2 kg	Refrigerated	3	Model WSED7667M Cut carrots into even size pieces (about 1-2 cm cube shape). Wash the carrots. Place carrots in the perforated tray on the wire grill. Put into the oven. To catch drippings from food, place the deep pan (or baking tray) below of the wire grill.
	Default 0.4 kg				
Grilled Vegetables *1*3	0.8 kg	-	Refrigerated	4	Ingredients Eggplants, cut into 1-2 cm thickness zucchinis, cut into 1-2 cm thickness onions, cut into wedges sweet peppers, cut in half lengthwise and discard seeds, whole cherry tomatoes, mushrooms-cut in half, butter (or oil) Method Brush vegetables with melted butter or oil and season as desired. Place food on the deep pan. Put into oven. When oven beeps, turn food over. After cooking, allow to rest covered with foil for 5 minutes. Use generated juice for gravy or sauce.

Potato					
Menu	Weight	Step	Food Temp.	Rack Position	Instructions
Roasted Potato *1*4*8*13	0.4-1.6 kg	0.2 kg	Room	2	Choose small potatoes (150-200 g each). Peel, wash, dry and cut potatoes into halves. Mix potatoes with salt, pepper and oil or melted butter. Place potatoes in a heat proof pan. Put into the oven. When oven beeps, turn food over.
	Default 1.0 kg				

72 OPERATION

Potato					
Menu	Weight	Step	Food Temp.	Rack Position	Instructions
Gratinated Potato *4*8*13	0.5-1.5 kg	0.5 kg	Room	2	Cut pre-cooked gratin potatoes with slices. Place potatoes in a heat proof pan, cover with grated cheese (30 g per 500 g gratin potatoes). Put into the oven.
	Default 1.0 kg				
Diced Potato *11*12	0.2-0.8 kg	0.2 kg	Room	3	Model WSED7667M Cut potatoes into even size pieces (about 1-2 cm cube shape). Wash the potatoes. Place diced potatoes in the perforated tray on the wire grill. Put into the oven. To catch drippings from food, place the deep pan (or baking tray) below of the wire grill.
	Default 0.4 kg				

Bread/Pastries					
Menu	Weight	Step	Food Temp.	Rack Position	Instructions
Umm Ali *3	1 serving	-	Room	3	<p>Ingredients 4 all-butter croissants, 2 tbsp. raisins or dried mixed berries, 2 tbsp. flaked/slivered almonds, 2 tbsp. pine nuts, 2 tbsp. roughly chopped shelled unsalted pistachios, 250 ml milk, 5 tbsp caster sugar, ¼ tsp ground cinnamon, 2 tsp orange blossom water, 250 ml whipping cream, 4 tbsp shredded coconut, 1 small egg (optional)</p> <p>Method Tear up the croissants into bite-size pieces, place on the baking sheet and bake in the 180 °C oven for 10 minutes until crisp and golden. Spread the baked croissant pieces across the base of a baking dish, about 23 cm in square. Sprinkle over the raisins, almonds, pine nuts and pistachios, making sure they are spread evenly. Heat the milk in a heavy-based saucepan over a medium heat, add 3 tablespoons of the sugar and mix well to dissolve. Reduce the heat to low, add the cinnamon and orange blossom water and heat through at a gentle simmer for 3-4 minutes. Remove the pan from the heat and leave it to cool so that the egg will not scramble when it's added to it. Put the cream and the remaining sugar in a mixing bowl and whisk until the mixture forms soft peaks. Sprinkle in the coconut and gently fold to incorporate. Add the egg to the cool milk mixture and whisk to combine. Ladle the mixture into the baking dish and spread the whipped cream over the top. Put into the oven.</p>

Bread/Pastries					
Menu	Weight	Step	Food Temp.	Rack Position	Instructions
Baklaw a ^{*3}	1 serving	-	Room	3	<p>Ingredients 175 g melted butter, 400 g thawed filo pastry, 2 tbsp. lemon juice, 4 tbsp. clear thick honey, 59 g caster sugar, finely grated rind of 1 lemon, 2 tsp cinnamon, 200 g blanched almonds copped, 200 g chopped walnuts, 75 g chopped pistachios or hazelnuts</p> <p>359 g caster sugar, 115 g clear honey, 600 ml water, 2 strips of thinly pared lemon rind, 1 tsp orange flower or rose water</p> <p>Method Brush the base of a shallow 30x20 cm loose-bottomed or Swiss roll tin (jelly roll pan) with a little of the melted butter. Using the tin as a guide, cut the sheets of filo pastry with a sharp knife so that they fit the tin exactly. To make filing, place the lemon juice, honey and sugar in a pan and heat gently until dissolved. Stir in the lemon rind, cinnamon and chopped nuts. Mix thoroughly. Spread half the filling over the pastry, cover with three layers of the filo pastry and butter then spread the remaining filling over the pastry. Finish by using up the remaining sheets of pastry and butter on top and brush the top of the pastry liberally with butter. Using a sharp knife, carefully mark the pastry into squares or diamond shape, almost cutting through the filing. Put into the oven. Place the caster sugar, honey, water and lemon rind in a pan and stir over a low heat until the mixture has thickened slightly. Take the syrup off the heat and leave to cool slightly. Remove the baklawa from the oven. Remove and discard the lemon rind from the syrup and stir in the orange flower or rose water, then pour over the pastry. Leave to soak for 6 hours. Cut into squares and serve, decorated with chopped pistachios.</p>

Bread/Pastries					
Menu	Weight	Step	Food Temp.	Rack Position	Instructions
Kobaiba *3	1 serving	-	Room	2	<p>Ingredients</p> <p>1 tbsp butter, 100 g coarsely ground or chopped walnuts, 750 g ground lamb (10 % fat), 500 g finely chopped onion, 1 tsp salt, 1 tsp freshly ground black pepper, ½ tsp ground allspice, 1 egg</p> <p>500 g fine grain bulgur, 500 ml water, 500 g lean ground lamb or beef, 1 onion, 1 tsp salt, 1 tsp freshly ground black pepper</p> <p>120 g room temperature butter, ½ cup blanched almond</p> <p>Method</p> <p>Melt the butter in a large saute pan set over medium heat, then add the walnuts and cook, stirring occasionally, for 10 to 15 minutes, until toasted. Remove from pan and add the ground lamb, onion, salt, pepper, and allspice. Cook, stirring often, until the juices evaporate, about 30 to 50 minutes. Remove from heat and stir in the toasted walnuts. Set aside to cool slightly, then add the egg and mix thoroughly. Put the bulgur in the bowl of a food processor, then add the water. Stir well with a fork and let sit for 15 minutes. Add the lamb or beef, onion, salt, and pepper, then pulse about 3 times, or just until malleable paste.</p> <p>Butter a 40x25 cm baking dish and spread half of the bulgur paste into the dish, patting with moistened hands to make it as even as possible. Next spread the filling, again making it as even as possible. Finish with the rest of the bulgur paste, pressing down with our hands to ensure that it sticks to the filling. Cut into 16 diamond shapes, make a small indentation in the center of each diamond, and press one almond in each dimple. Spread the butter over the kobaiba using hand. Put into the oven. Remove from the oven and sprinkle some water over top with fingers.</p>

Bread/Pastries					
Menu	Weight	Step	Food Temp.	Rack Position	Instructions
Cookies *4*9*13	1 serving	-	Refrigerated	2	<p>Ingredients (2 servings) 250 g butter, 250 g sugar, 500 g flour, 3 eggs, 2 g salt, 1 packet vanilla sugar (ca. 8 g), 1 egg yolk and milk</p> <p>Method Method Cream together the butter, sugar, vanilla sugar and salt. Gradually add the eggs. Add the flour and mix it with the butter mixture. Cover and put the dough overnight in a refrigerator. Portions of the dough roll out about 5 mm thick. Cut out the rolled out dough with various cutters and place on greased baking sheet. Mix the egg yolk with a little bit milk and brush the surface of the cookies with it. Put into the oven.</p>
Muffins *4*10*13	1 serving	-	Room	2	<p>Ingredients 150 g flour, 1 ½ tsp baking powder, 60 g granulated sugar, 1 egg beaten, 130 ml milk, 70 ml vegetable oil, ½ tsp vanilla extract, 50 g semisweet chocolate chips, 50 g chopped walnuts, sifted confectioners' sugar</p> <p>Method Ingredients 150 g flour, 1 ½ tsp baking powder, 60 g granulated sugar, 1 egg beaten, 130 ml milk, 70 ml vegetable oil, ½ tsp vanilla extract, 50 g semisweet chocolate chips, 50 g chopped walnuts, sifted confectioners' sugar Method Combine flour and sugar in a mixing bowl; make a well in center of mixture. Combine remaining ingredients except for confectioners' sugar; add to dry ingredients, stir just until moistened. Spoon into greased and floured muffin pan, filling about two-thirds full. Put into the oven. Remove from pans and sprinkle with confectioners' sugar.</p>

Bread/Pastries					
Menu	Weight	Step	Food Temp.	Rack Position	Instructions
Buns *4*9	1 serving	-	Room	3	<p>Ingredients 400 g flour, 200 ml warm milk, 70 g sugar, 30 g yeast, 50 g butter, 15 g vanilla sugar, 2 g salt, 120 g raisins (optional)</p> <p>Method Method Put the flour in a mixing bowl and make a well. Add yeast and 20 g sugar to milk and mix. Pour the liquid into the well and cover with some flour. Leave to rise in a warm place until cracks appear on the surface. Add the remaining sugar, softened butter, vanilla sugar, salt and knead into a smooth yeast dough. Let the dough rise in a warm place until it doubles in size. Put raisins into the batter. Divide the dough into 12 pieces and shape into rounds. Place on a baking sheet lined with parchment paper on the wire grill. Let rise again and brush with milk. Put into the oven.</p>
Brownies *4*8*13	1 serving	-	Room	2	<p>Ingredients 225 g melted butter, 400 g white sugar, 100 g cocoa powder, 1 tsp vanilla extract, 2 eggs, 130 g all-purpose flour, ½ tsp baking powder, ½ tsp salt, 70 g walnut halves</p> <p>Method Combine the melted butter, sugar, cocoa powder and mix well. Add vanilla, eggs, flour, baking powder and salt. Spread the batter into the heat proof pan lined with baking paper. Decorate with walnut halves, if desired. Put into the oven.</p>

Bread/Pastries					
Menu	Weight	Step	Food Temp.	Rack Position	Instructions
Apple Pie *4*13	1 serving	-	Refrigerated	3	<p>Ingredients 150 g white sugar, 2 tbsp all-purpose flour, ½ tsp ground cinnamon, ¼ tsp ground nutmeg, ½ tsp lemon zest, 1.2 kg thinly sliced apples, 2 tsp lemon juice, 1 tbsp butter, 1 recipe pastry for a 9 inch double crust pie, 4 tbsp milk (optional)</p> <p>Method Mix together the sugar, flour, cinnamon, nutmeg and lemon zest. Line one crust in a 9-inch deep-dish pie pan. Layer 1/3 of apples on pie crust. Sprinkle with sugar mixture and repeat until done. Sprinkle with lemon juice and dot with butter. Place second pie crust on top of filling and flute the edges. Cut vents in top crust and brush with milk for a glazed appearance if desired. Put into the oven.</p>

Pizza					
Menu	Weight	Step	Food Temp.	Rack Position	Instructions
Frozen Pizza (thin base)	0.2-0.4 kg	0.1 kg	Frozen	2	Place frozen pizza on the wire grill. Put into the oven. Use only one frozen pizza at a time.
	Default 0.3 kg				
Frozen Pizza (thick base)	0.5 kg	-	Frozen	2	Place frozen pizza on the wire grill. Put into the oven. Use only one frozen pizza at a time.

Pizza					
Menu	Weight	Step	Food Temp.	Rack Position	Instructions
Homemade Pizza *4*9*13	1 serving	-	Room	2	<p>Ingredients 20 g yeast, 200 ml warm water, 5 g salt, 350 g flour, 10 g sugar, 10 g vegetable oil, 1 small jar tomato sauce, 250 g grated cheese, 200 g Mozzarella cheese, 1 small can of sliced mushrooms, oregano, salt, pepper</p> <p>Method Dissolve yeast in warm water. Stir in salt and sugar. Add flour slowly, kneading constantly. Add oil and keep kneading. If dough is sticky, add a little more flour. Cover dough and allow to rise for ½ hour. Using floured hands, knead dough and spread it on greased baking sheet with fingertips. Spread tomato sauce over dough, add toppings in layers. Sprinkle cheese over dough. Put into the oven.</p>

• **White Bread** (1 searving)^{*4*11*13}

- Category : **Bread/Pastries**
- Food Temperature: Room
- Rack Position: 3
- Ingredients: 400 g bread flour, 100 g all-purpose flour, 300 g water, 10 g instant yeast, 8 g salt
- Method
 - 1) In a mixing bowl of a stand mixer, whisk together the bread flour and all-purpose flour, yeast and salt. Make sure that the salt and yeast do not come into direct contact.
 - 2) With a paddle attachment, slowly pour in water. Then switch to a dough hook and knead for 8 minutes.
 - 3) Transfer dough to a lightly flour-dusted work surface. Shape the dough into a ball. Cover with plastic wrap. Let rest for 30 minutes.
 - 4) Knead dough for 5 minutes by hand. Cover the dough and let rest 1 ½ hours. Stretch and fold the dough. Start from the top of the dough pull forwards (away from you) then bring it to the middle.
 - 5) Then pull bottom of the dough backward (towards yourself) and fold to the middle.
 - 6) Place a loaf pan on the wire grill. Put into oven.

• **Baguette** (1 serving)^{*11*12*13}

- Category : **Bread/Pastries**
- Food Temperature: Room
- Rack Position: 3
- Ingredients: 400 g Bread flour, 100 g All-purpose flour, 300 g Water, 10 g Instant yeast, 8 g Salt
- Method

- 1) In a mixing bowl of a stand up mixer, whisk together the bread flour, all-purpose flour, yeast and salt.
- 2) With a paddle attachment, slowly add the water. Then switch to a dough hook and knead for 8 minutes.
- 3) Turn the dough out onto a lightly flour-dusted countertop. Shape into a ball. Cover with plastic wrap. Let rest for 30 minutes.
- 4) Knead the dough by hand for 1-3 minutes. Cover the dough and let rest 1 ½ hours.
- 5) Decompress the dough by gently indenting with fingers into the center of the dough. Stretch and fold the dough. Working along the length of the dough, start from the upper edge of the dough, pull forward, away from you and then bring it to the center. Pull the bottom of the dough backwards (toward yourself) and fold to the center.
- 6) Do the same for the left and right side of the dough.
- 7) Flip the dough and cover with plastic wrap. Let rest 1 hour.
- 8) Divide the dough into two equal portions. Shape the dough into 6" cylinders. Working with one piece of dough at a time (keeping the other covered in plastic wrap), shape into a rectangle. Working along the length of the dough, press with three fingers gently making several indentations into the dough.
- 9) Repeat the process; roll the dough over onto itself three times until the upper edge meets the lower edge and creates a deep seam. Sealing each turn with your fingers. Pinch the seam tight and let rest for about 5 minutes (or when the dough is relaxed enough to roll) with the seam facing up. Cover with a towel. Roll and shape the baguettes to fit a perforated baguette pan.
- 10) Place on a baguette pan, seam side down, and let rest for about 5 minutes covered with a towel. Make five cuts on the surface of the dough.
- 11) Place a perforated baguette pan on the wire grill. Put into the oven.

*1 After the BEEP, turn the food over.

*2 After the BEEP, remove the lid.

*3 Use wire grill over the deep pan (or baking tray).

*4 Use wire grill.

*5 Use your own heat proof glass dish on the wire grill.

*6 Use deep pan (or baking tray).

*7 Use your roasting pot.

*8 Use your heat proof pan.

*9 Use your baking sheet.

*10 Use your muffin pan.

*11 Fill the water tank to the max line located at the front of the tank.

*12 Use perforated tray on the wire grill over the deep pan.

*13 Use your own cooking containers.

My Recipes

My Recipes allows you to download a new and special cooking recipe to your appliance with a smartphone. Cook food according to your preference.

Install the **LG ThinQ** application in your smartphone. Follow the instructions on the **LG ThinQ** application to create, edit or delete **My Recipes**. If the appliance is connected to a home Wi-Fi network and the **LG ThinQ** application, **My Recipes** can be downloaded to the appliance.

NOTE

- Creating, editing, or deleting **My Recipes** is only available in the **LG ThinQ** application.

- Make sure to remove the probe from the oven before using the **My Recipes** feature (Model WSED7667M).
 - To change the **My Recipes** settings permanently, edit the recipe in the **LG ThinQ** application.
-

Setting My Recipes Mode

- 1) Press **My Recipes** in the **Main Menu** screen.
- 2) Select one of the created recipes.
- 3) Press the **Start/Stop** button on the control panel.

To Stop Cooking

- 1) Press the **Start/Stop** button on the control panel, then press **Stop** in the display.

Information for Test Institutes

This table is only for use by test institutes. It includes the best settings for the test recipes out of the standard IEC 60350-1.

Dish	Heating Mode	Temp. (°C)	Accessories	Rack Position	Preheat	Cooking Time (minute)	Handlings
Small cake	Top Bottom Heat	170	Baking tray	3	Yes	20-30	-
	Hot Air	150	Baking tray	3	Yes	20-30	-
	Hot Air	150	Baking tray / Deep pan	4 / 2	Yes	25-35	Baking tray at the 4, Deep pan at the 2 from down
Sponge cake	Top Bottom Heat	170	Wire grill	2	Yes	20-30	-
	Hot Air	160	Wire grill	3	Yes	30-40	-
Apple pie	Top Bottom Heat	180	Wire grill	1	No	65-75	One tin in the left back and the other one in the right front
	Hot Air	170	Wire grill	2	No	65-75	
Pastry stripes	Top Bottom Heat	170	Baking tray	3	Yes	20-30	-
	Hot Air	140	Baking tray	3	Yes	20-30	-
			Baking tray / Deep pan	4 / 2	Yes	20-30	Baking tray at the 4, Deep pan at the 2 from down
Toast	Large Grill	Low	Wire grill	4	Yes 5 minutes	2-4	-
Beef steak	Large Grill	High	Wire grill	4 / 1	Yes 5 minutes	10-15 each side	Turn after half time
Meringue	Hot Air	80	Baking tray	3	No	120-150	-

Dish	Heating Mode	Temp. (°C)	Accessories	Rack Position	Preheat	Cooking Time (minute)	Handlings
Roast Chicken	Roasting	190	Wire grill / Deep pan	2	Yes	55-65	Turn after half time

84 OPERATION

Steam

- Model WSED7667M

Dish	Heating Mode	Temp. (°C)	Accessories	Rack Position	Preheat	Cooking Time (minute)	Handlings
Broccoli : 300 g	Steam	99	Perforated tray	3	No	12-18	Baking tray at the 2, from down
Broccoli : 2 x 300 g	Steam	99	Perforated tray	3	No	12-18	Baking tray at the 2, from down
Broccoli : max. amount	Steam	99	Perforated tray	3	No	15-20	Baking tray at the 2, from down
Peas: 800 g	Steam	99	Perforated tray	3	No	-	Baking tray at the 2, from down

SMART FUNCTIONS

LG ThinQ Application

This feature is only available on models with Wi-Fi. The **LG ThinQ** application allows you to communicate with the appliance using a smartphone.

LG ThinQ Application Features

Communicate with the appliance from a smartphone using the convenient smart features.

• Settings

- Allows you to set various options on the oven and in the application.

• My Recipes

- Download new and special cooking recipes that are not included in the standard cooking mode on the appliance. Once **My Recipes** download is completed in the appliance, the appliance keeps the recipes. You can only create, edit or delete the recipes in the **LG ThinQ** application.

• Smart Diagnosis

- This function provides useful information for diagnosing and solving issues with the appliance based on the pattern of use.

• Monitoring

- This function helps you check the current status, remaining time, cook settings and end time in one place.

• Product Notifications

- Turn on the Push Alerts to receive appliance status notifications. The notifications are triggered even if the **LG ThinQ** application is not open.

• Timer

- You can set the timer from the application.

• Firmware Update

- Keep the appliance updated.

NOTE

- In the following cases, you must update the network information for each appliance in the

LG ThinQ application under **Device Cards** → **Settings** → **Change Network**.

- wireless router is changed
- wireless router password is changed
- Internet service provider is changed
- This information is current at the time of publication. The application is subject to change for product improvement purposes without notice to users.
- Functions may vary by model.

Installing LG ThinQ Application and Connecting an LG Appliance

Scan the QR code attached to the product using the camera or a QR code reader application on your smartphone.

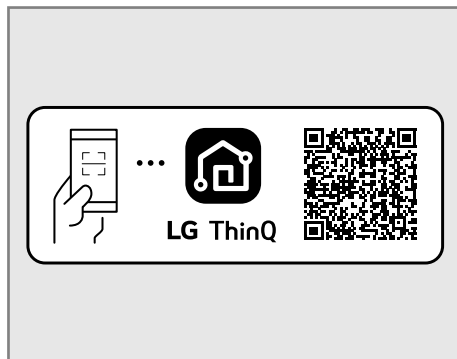

NOTE

- To verify the Wi-Fi connection, check that the  icon on the control panel is lit.
- The appliance supports 2.4 GHz Wi-Fi networks only. To check your network frequency, contact your Internet service provider or refer to your wireless router manual.

NOTE

- **LG ThinQ** is not responsible for any network connection problems or any faults, malfunctions, or errors caused by network connection.
- The surrounding wireless environment can make the wireless network service run slowly.
- If the appliance is having trouble connecting to the Wi-Fi network, it may be too far from the router. Purchase a Wi-Fi repeater (range extender) to improve the Wi-Fi signal strength.
- The network connection may not work properly depending on the Internet service provider.
- The Wi-Fi may not connect or the connection may be interrupted because of the home network environment.
- If the appliance cannot be connected due to problems with the wireless signal transmission, unplug the appliance and wait about a minute before trying again.
- The wireless network name (SSID) should be a combination of English letters and numbers. (Do not use special characters.)
- Smartphone user interface (UI) may vary depending on the mobile operating system (OS) and the manufacturer.
- If the security protocol of the router is set to **WEP**, network setup may fail. Change the security protocol (**WPA2** is recommended), and connect the product again.

Open Source Software Notice Information

To obtain the source code that is contained in this product, under GPL, LGPL, MPL, and other open source licenses that have the obligation to disclose source code, and to access all referred license terms, copyright notices, please visit <https://opensource.lge.com>.

LG Electronics will also provide open source code to you for a charge covering the cost of performing such distribution upon email request to opensource@lge.com.

This offer is valid to anyone in receipt of this information for a period of three years after our last shipment of this product.

Smart Diagnosis Feature

Use this feature to help you diagnose and solve problems with your appliance.

NOTE

- For reasons not attributable to LGE's negligence, the service may not operate due to external factors such as, but not limited to, Wi-Fi unavailability, Wi-Fi disconnection, local app store policy, or app unavailability.
- The feature may be subject to change without prior notice and may have a different form depending on where you are located.

Using LG ThinQ to Diagnose Issues

If you experience a problem with your Wi-Fi equipped appliance, it can transmit troubleshooting data to a smartphone using the **LG ThinQ** application.

- Launch the **LG ThinQ** application and select the **Smart Diagnosis** feature in the menu. Follow the instructions provided in the **LG ThinQ** application.

Using Audible Diagnosis to Diagnose Issues

Follow the instructions below to use the audible diagnosis method.

- Launch the **LG ThinQ** application and select the **Smart Diagnosis** feature in the menu. Follow the instructions for audible diagnosis provided in the **LG ThinQ** application.
- 1) Press **Settings** at the right bottom of the **Main Menu** screen, swipe the screen, then press **Smart Diagnosis**.
 - If the display has been locked, you must deactivate the lock and then reactivate it.

- 2) Place your phone's mouthpiece near the top left corner of the screen.

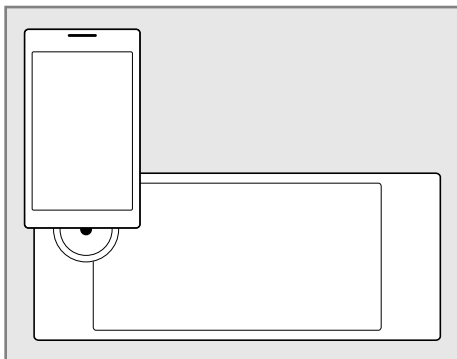

- 3) Keep the phone in place until the tone transmission has finished. The display will count down the time. Once the countdown is over and the tones have stopped, the diagnosis will be displayed in the application.

NOTE

- For best results, do not move the phone while the tones are being transmitted.
-

MAINTENANCE

Cleaning

Interior

WARNING

- Never wipe a warm or hot porcelain surface with a damp sponge; it may cause chipping or crazing (tiny hairlike cracks).

CAUTION

- Do not use oven cleaners, steam cleaners, harsh chemical cleaners, bleach, vinegar, steel scouring pads, or abrasive pads or cleansers to clean the oven, as they can permanently damage the oven surface.
- Do not clean the gasket.
- Do not clean the interior with the oven light on.
- To prevent burns, wait until the oven has cooled down before touching any of its parts.

Do not use oven cleaners to clean the oven cavity. Use the product's **EasyClean** function regularly to clean light soil. For stubborn soil, clean manually using the following tips.

- A plastic spatula can be used as a scraper to scrape off any chunks or debris before and after oven cleaning.
- Using the rough side of a non-scratch scouring pad may help to take off burnt-on stains better than a soft sponge or towel.
- Certain non-scratch scrubbing sponges, such as those made of melamine foam, available at local stores, can also help improve cleaning.
- Food spills should be cleaned when the oven cools immediately after the cooking has ended. Leaving spills or splatter unattended to may cause surface etching or discoloration.
- At high temperature, foods react with porcelain and a permanent dull spot can result. When cleaning a spot, use only non-abrasive cleaners or scrubbers.
- When cleaning a spot, use only non-abrasive cleaners or scrubbers.

Exterior

Painted and Decorative Trim

For general cleaning, use a cloth with hot soapy water. For more difficult soils and built-up grease, apply a liquid detergent directly onto the soil. Leave it on for 30 to 60 minutes. Rinse with a damp cloth and dry. Do not use abrasive cleaners.

Stainless Steel Surfaces

WARNING

- To avoid scratches, do not use steel wool pads.

NOTE

- To clean the stainless steel surface, use warm sudsy water or a stainless steel cleaner or polish.
- Always wipe in the direction of the metal surface finish.
- Stainless steel appliance cleaner or polish can be purchased online or from most retailers of appliances or home goods.

- 1) Place a small amount of stainless steel appliance cleaner or polish on a damp cloth or paper towel.
- 2) Clean a small area, rubbing with the grain of the stainless steel if applicable.
- 3) Dry and buff with a clean, dry paper towel or soft cloth.
- 4) Repeat as necessary.

Oven Door

CAUTION

- Do not use harsh cleaners or harsh abrasive cleaning materials on the outside of the oven door. Doing so can cause damage.
- Do not use harsh abrasive cleaners or sharp metal scrapers to clean the oven door glass, since they can scratch the surface, which may result in shattering of the glass.

- Do not use oven cleaners, cleaning powders, or harsh abrasive cleaning materials on the outside of the oven door.
- Do not force the oven door open when the lock icon is displayed. The oven door remains locked until the oven temperature has cooled. Forcing the door open will damage the door.

- Use soapy water to thoroughly clean the oven door. Rinse well. Do not immerse the door in water.
- You may use a glass cleaner on the outside glass of the oven door. Do not spray water or glass cleaner on the door vents.
- Do not clean the oven door gasket. The oven door gasket is made of a fiberglass material that is essential for a good seal. Care should be taken not to rub, damage, or remove this gasket.

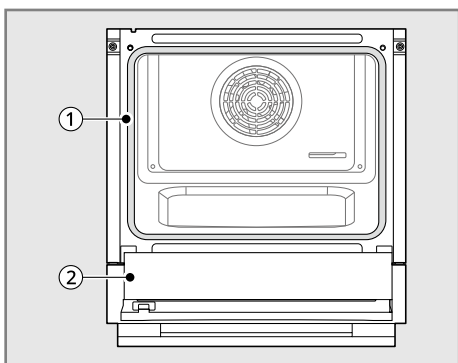

①	Don't hand clean oven door gasket
②	Do hand clean door

Oven Racks

Remove the oven racks before cleaning them.

- 1) Clean with a mild, abrasive cleaner.
 - Food spilled into the tracks could cause the racks to become stuck.
- 2) Rinse with clean water and dry.

Accessories

- Clean the wire grill, baking tray, and other accessories with a soft cloth and hot, soapy water.
- Do not clean the accessories in the dishwasher.

EasyClean

The **EasyClean** feature takes advantage of LG's new enamel to help lift soils without harsh chemicals, and it runs using **ONLY WATER** for just 10 minutes in low temperatures to help loosen **LIGHT** soils before hand cleaning.

Your LG oven gives you the option of cleaning with **LESS HEAT, LESS TIME,** and virtually **NO SMOKE OR FUMES.** You can reduce energy use by cleaning light oven soils with the **EasyClean** feature.

Benefits of EasyClean

- Helps loosen light soils before hand-cleaning.
- **EasyClean** only uses water; no chemical cleaners.
- Minimizes smoke and odors.

When to Use EasyClean

- Example of oven soiling

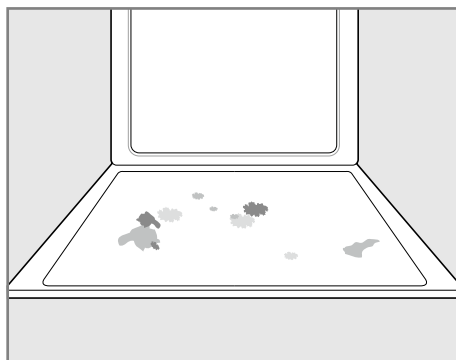

Case 1

- Soil pattern: Small drops or spots
- Types of soils: Cheese or other ingredients
- Common food items that can soil your oven: Pizza

Case 2

- Soil pattern: Light splatter
- Types of soils: Fat/grease
- Common food items that can soil your oven: Steaks, grilled / Fish, grilled / Meat roasted at low temperatures

EasyClean Instruction Guide**⚠ CAUTION**

- The oven should be level to ensure that the bottom surface of the oven cavity is entirely covered by water at the beginning of the **EasyClean** cycle.
- Do not open the oven door during the **EasyClean** cycle. Water will not get hot enough if the door is opened during the cycle.
- Some surfaces may be hot after the **EasyClean** cycle. Wear rubber gloves while cleaning to prevent burns.
- During the **EasyClean** cycle, the oven becomes hot enough to cause burns. Wait until the cycle is over before wiping the inside surface of the oven. Failure to do so may result in burns.
- Avoid leaning or resting on the oven door glass while cleaning the oven cavity.
- Do not use any steel scouring pads, abrasive pads or cleaners as these materials can permanently damage the oven surface.
- Do not use oven cleaners. Commercial oven cleaner or oven liner protective coating of any kind should not be used in or around any part of the oven.
- Remove the baking tray, deep baking tray, wire grill, all cookware, aluminum foil or any other material from the oven.
- Do not clean the gasket. The fiberglass material of the oven door gasket cannot withstand abrasion. It is essential for the gasket to remain intact. If you notice it becoming worn or frayed, replace it by a service technician.
- As the oven heats, you may hear sounds of metal parts expanding and contracting. This is normal and will not damage the oven.
- Once the door has been locked, the lock  indicator light stops flashing and remains on.

Allow about 15 seconds for the oven door lock to activate.

NOTE

- Allow the oven to cool to room temperature before using the **EasyClean** cycle. If your oven cavity is above 65 °C, the **EasyClean** cycle will not be activated until the oven cavity cools down.
- For best results, use distilled or filtered water. Tap water may leave mineral deposits on the oven bottom.
- Soil baked on through several cooking cycles will be more difficult to remove with the **EasyClean** cycle.

- 1) Remove oven racks and accessories from the oven.
- 2) Scrape off and remove any burnt-on debris with a plastic scraper.

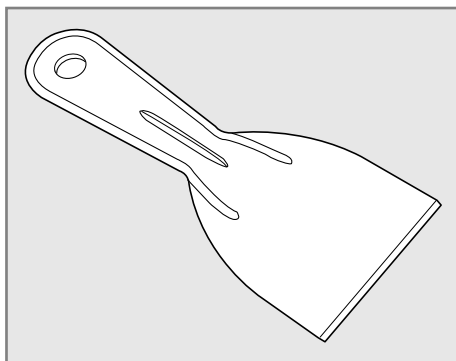

- Suggested plastic scrapers:
 - Hard plastic spatula
 - Plastic pan scraper
 - Plastic paint scraper
 - Old credit card
- 3) Fill the tank to the **Max** line. Use softened, filtered water, if possible. Hard water may clog the steam generator more quickly with scale buildup.
 - 4) Press **Cleaning** in the **Main Menu** screen, then press **EasyClean**.

- 5) Press the **Start/Stop** button on the control panel. The remaining time appears in the display.
- 6) A tone will sound at the end of the 10 minutes cycle and **Cleaning is finished** appears in the display. Press the **Start/Stop** button on the display.
- 7) After the cleaning cycle and during hand-cleaning, enough water should remain on the oven bottom to completely submerge all soils. Add water if necessary. Place a towel on the floor in front of the oven to capture any water that may spill out during hand-cleaning.
- 8) Clean the oven cavity immediately after the **EasyClean** cycle by scrubbing with a wet, non-scratch scouring sponge or pad. (The scouring side will not scratch the finish.) Some water may spill into the bottom vents while cleaning, but it will be captured in a pan under the oven cavity and will not hurt the burner.
- 9) Once the oven cavity is cleaned, wipe any excess water with a clean dry towel. Replace racks and any other accessories.
- 10) If some light soils remain, repeat the above steps, making sure to thoroughly soak the soiled areas.
 - Be sure that the oven cavity is empty of oven racks and other accessories.

NOTE

- The cavity gasket may be wet when the **EasyClean** cycle finishes. This is normal. Do not clean the gasket.
- If mineral deposits remain on the oven bottom after cleaning, use a cloth or sponge soaked in vinegar to remove them.
- Using commercial oven cleaners or bleach to clean the oven is not recommended. Instead, use a mild liquid cleanser with a pH value below 12.7 to avoid discoloring the enamel.

Cleaning the Water Tank

The water tank is used during the steam cooking functions. Use filtered, softened water if possible.

NOTE

- After using the steam function, the water tank should be drained. To avoid bacteria or odors, clean and dry the steam feeder tank after every use.
- Do not clean in a dishwasher.
- If the water tank does not slide in as smoothly as it should, clean the bottom of the tank.

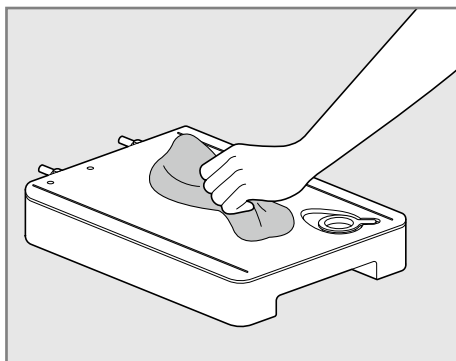

Hard Water Scale

If hard water is used in the water tank, the steam generator may become clogged with hard water scale. In areas with hard water, run the **Descaling** function frequently or use softened water.

Using Descaling Function

To remove mineral deposits that remain on the oven bottom after using the steam mode, use a cloth or sponge soaked in vinegar or a weak citric acid solution. For more stubborn or extensive scaling, use the **Descaling** function.

NOTE

- Use the Descaling function after every 2-3 uses of steam mode.

Descaling

Use this function to remove the white deposits that form after the steam generator is used for a long period.

The **Descaling** function runs for 1 hour 43 minutes. Water will come out of the steam generator while it is being cleaned.

For instructions on removing and filling the water tank, see "**Using the Water Tank.**"

Setting Descaling

NOTE

- After a power failure, the **Descaling** function will resume automatically even if the **Rinsing** function was running.
- If water remains on the oven bottom after descaling, see the instructions under "**Using Draining Function**" for residual water inside the steam generator.
- After running the **Descaling** function, clean the water tank.

- 1) Fill the water tank with a premixed 50:1 mixture of water and citric acid. For example, use 4 tsp of citric acid in 4 1/4 cups water (20 g citric acid in 1000 ml water).
- 2) Carefully insert the water tank into correct position in the control panel, making sure to keep the tank level while carrying it. If the tank is not kept level, water will drain out of the tubes in the back.
- 3) Press **Cleaning** in the **Main Menu** screen. Press **Steam Maintenance**, then press **Descaling**.
- 4) After 1 hour 32 minutes of descaling, a popup will appear in the display. Following the instructions, drain the tank and fill it with clean water.
- 5) Insert the tank and start the **Rinsing** function. The **Rinsing** takes about 11 minutes.
- 6) Once the **Rinsing** function is complete, dry the inside of the oven with a soft cloth. Leave the oven door open and allow the oven to dry completely.

Using Draining Function

The **Draining** function removes residual water inside the steam generator. The function takes a little over 1 minute and runs automatically after

any steam cooking cycle. The **Draining** function can also be started manually, if needed.

Setting Draining

- 1) Make sure that the water tank is empty.
- 2) Press **Cleaning** in the **Main Menu** screen. Press **Steam Maintenance**, then press **Draining**.
- 3) Press the **Start/Stop** button on the display to begin **Draining**. The remaining time appears in the display.

Using Evaporation Function

The **Evaporation** function removes residual water inside the oven cavity. The function takes a little over 20 minutes.

Setting Evaporation

- 1) Press **Cleaning** in the **Main Menu** screen. Press **Steam Maintenance**, then press **Evaporation**.
- 2) Press the **Start/Stop** button on the display to begin **Evaporation**. The remaining time appears in the display.

Periodic Maintenance

Changing the Oven Light

Model WSED7667M

The oven light is a standard LED lamp. If the LED lamp does not turn on, please contact the LG Electronics Customer Service. Do not attempt to replace or remove the LED lamp.

Model WSED7665B

The oven light is a standard 25-watt or 40-watt appliance halogen. Please read the following instructions to replace the halogen lamp.

WARNING

- Ensure that the appliance is switched off before replacing the lamp to avoid the possibility of electric shock.

- Make sure that the oven and bulb are cool.
- Disconnect the electrical power to the appliance at the main fuse or circuit breaker panel. Failure to do so can result in severe personal injury, death, or electrical shock.
- Wear gloves while changing the oven light. Glass fragments from broken bulbs can cause risk of injury.
- If you apply force, the glass or oven may crack

- 1) Unplug the oven or disconnect power.
- 2) Turn the glass lamp cover counterclockwise to remove.
- 3) Remove the halogen lamp from the socket and dispose it in an environmentally friendly way.
- 4) Insert the new halogen lamp. Do not touch the lamp with your fingers when inserting as it can cause the lamp to fail.
- 5) Insert the glass lamp cover and turn it clockwise.
- 6) Plug in the range or reconnect the power.

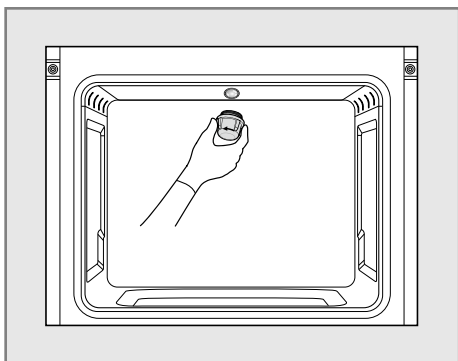

Removing, Assembling and Dismantling the Oven Door

Removing and dismantling the oven door may be needed to achieve better cleaning results. The oven door contains glass that can break. Care should be taken when removing, assembling and dismantling the oven door.

⚠ CAUTION

- To prevent burns, wait until the oven has cooled down before touching any of its parts.
- The door is very heavy. Be careful when removing, lifting and replacing the door.
- Do not lift the door by its handle. The handle is not designed to support the weight of the door when it has been removed from the oven.
- Do not hit the glass with pots, pans, or any other object.
- Scratching, hitting, jarring or stressing the glass may weaken its structure, causing an increased risk of breakage at a later time.
- Do not close the oven door until all the oven racks are fully in place.

Removing the Oven Door

⚠ CAUTION

- Clip the clamp completely in order to prevent damaging the oven cavity.

- 1) Fully open the door.
- 2) Lift up the door clamp ② and flip it towards the oven ① completely.

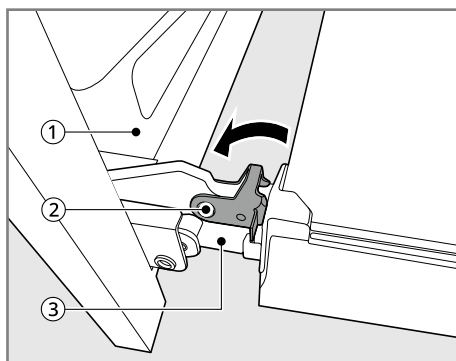

- 3) Firmly grasp both sides of the door at the top.

- Partially close the door to approximately 70 degrees ④. If the position is correct, the hinges ③ will move freely.

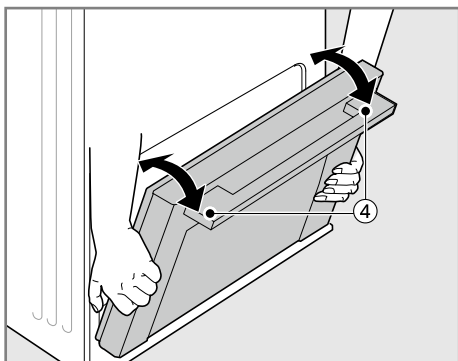

- Lift and pull the door towards you until the hinge latches are completely loosened.

- Fully insert the hinges ② into the slots ③.

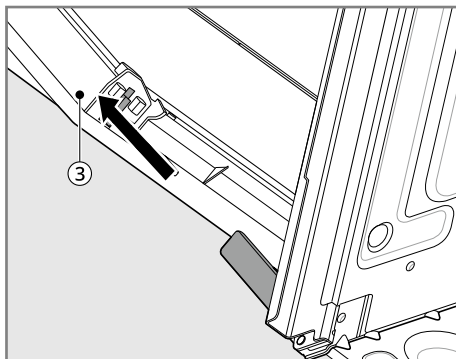

- Slowly open the door fully. Make sure that the hinges ② are properly engaged in the slots ③.
- Lift up the door clamp ④ and flip it towards the oven door ① until it clicks into position.

Assembling the Oven Door

- Firmly grasp both sides of the door ① near the top.

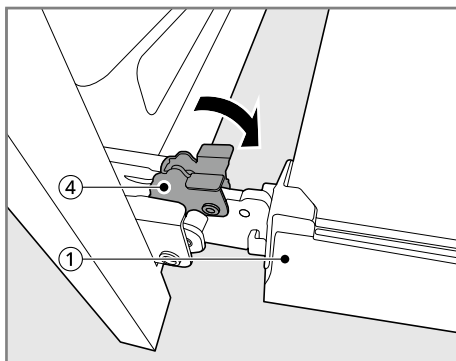
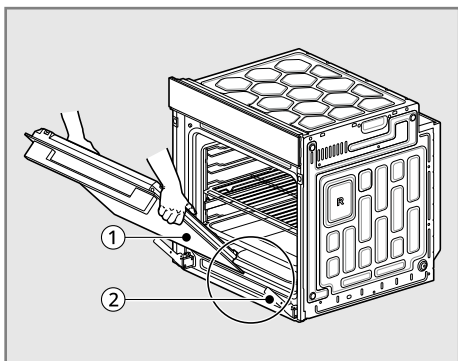

- Close the door.

Dismantling the Oven Door

The oven door contains three layers of glass panels. Remove the oven door from the oven before dismantling the oven door.

- Remove the oven door from the oven and place it on a soft, flat surface to prevent breakage and scratching with the door handle facing the floor.

- 2) Push the locks ① on both sides of the door top cover ② and pull forwards.

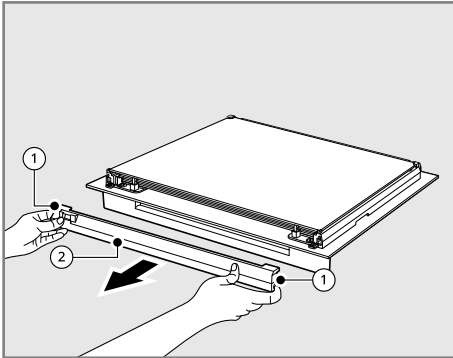

- 3) With both hands, grab and lift up the glass panel ③ slightly and pull forward to remove it from the oven door.

Set aside the gasket (4 ea) inserted into glass. Repeat to remove all three layers of glass panels.

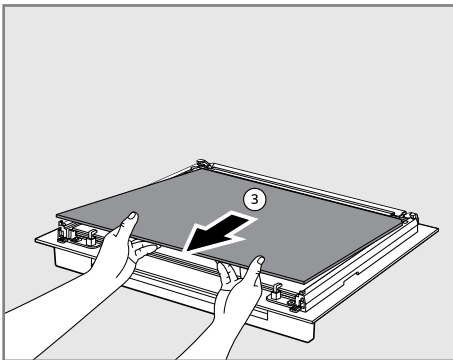

- Place the glass panel as the **LG** printed side toward the oven door handle.

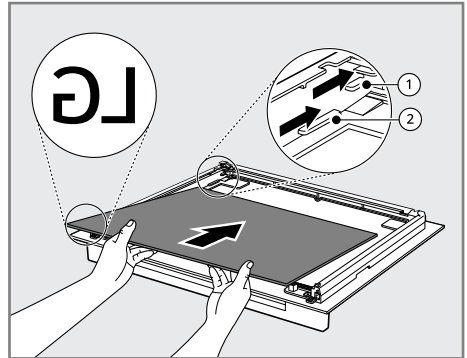

- 2) Assemble the 4 packings on the second glass panel as follows.

- The packings hold the glass in place reducing noise and vibration in a door.

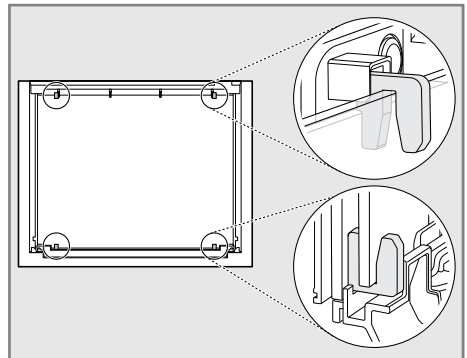

- 3) Slide in the top glass panel ③ on top of the second glass panel into the oven door.

Assembling the Glass Panel

Assemble the glass panels in the reverse sequence of its removal.

- 1) Slide in the bottom glass panel into ② and the second glass panel into ① of the oven door.

- If correctly placed, you will see **TOP** printed on the bottom of the glass panel to indicate the correct surface orientation.

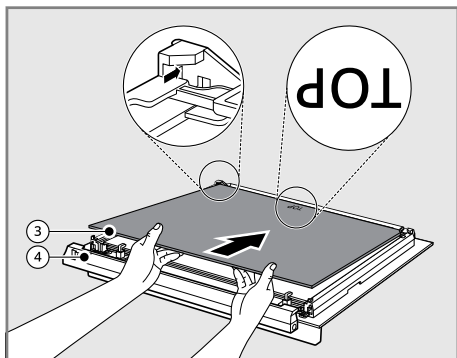

- 4) Assemble the door top cover⁴.
- Ensure that it is fixed (click!).

TROUBLESHOOTING

FAQs

Frequently Asked Questions

Q: My new oven doesn't cook like my old one. Is there something wrong with the temperature settings?

A: No. Your oven has been factory tested and calibrated. For the first few uses, follow your recipe times and temperatures carefully. If you still think your new oven is too hot or too cold, you can adjust the oven temperature yourself to meet your specific cooking needs. Refer to the **Changing Settings** section in this manual for easy instructions on how to adjust your thermostat.

Q: Is it normal to hear a clicking noise coming from the back of my oven when I am using it?

A: Your new appliance is designed to maintain a tighter control over your oven's temperature. You may hear your oven's heating elements click on and off more frequently on your new oven. This is normal.

Q: During convection cooking the fan stops when I open the door. Is that normal?

A: Yes, this is normal. When the door is opened, the convection fan will stop until the door is closed.

Q: Can I use aluminum foil to catch drippings in my oven cavity?

A: Never use aluminum foil to line the bottom or sides of the oven. The foil will melt and stick to the bottom surface of the oven and will not be removable. Use a foil-lined sheet pan placed on a lower oven rack to catch drippings instead. Never place any rack, tray or pan on the base of the oven. (If foil has already melted onto the bottom of the oven, it will not interfere with the oven's performance.)

Q: Can I use aluminum foil on the racks?

A: Do not cover racks with aluminum foil. Covering entire racks with foil restricts air flow, leading to poor cooking results. Use a sheet pan lined with foil under fruit pies or other acidic or sugary foods to prevent spillovers from damaging the oven finish.

CAUTION

- Foil may be used to wrap food in the oven, but do not allow the foil to come into contact with the exposed heating/grilling elements in the oven. The foil could melt or ignite, causing smoke, fire, or injury.

Q: What should I do if my racks are sticky and have become hard to slide in and out?

A: Over time, the racks may become hard to slide in and out. Apply a small amount of olive oil to the sides of the racks. This will work as a lubricant for easier gliding.

Q: Should I grill with the door open or closed?

A: Your electric oven isn't designed for open door grilling. If you grill with the oven door open, it can damage the oven door or display.

Q: Why aren't the function buttons working?

A: Check if **Control Lock** is activated. The lock icon  will show in the display if **Control Lock** is activated. To deactivate **Control Lock**, refer to the **Control Lock** in **Operation** chapter.

Q: How can I help keep children safe around the appliance?

A: Children should be supervised around the appliance whenever it is in use, and after use until the oven surfaces have cooled. You can also use **Control Lock** to prevent children from accidentally turning on the oven. **Control Lock** disables most of oven controls. Refer to the **Control Lock** in **Operation** section.

Before Calling for Service

Cooking

Symptoms	Possible Cause & Solution
Oven will not work	Plug on appliance is not completely inserted in the electrical outlet. <ul style="list-style-type: none"> • Make sure electrical plug is plugged into a live, properly grounded outlet.
	A fuse in your home may be blown or the circuit breaker tripped. <ul style="list-style-type: none"> • Replace the fuse or reset the circuit breaker.
	Oven controls improperly set. <ul style="list-style-type: none"> • See the "Operating the Oven" section in the Operation chapter.
	Oven too hot. <ul style="list-style-type: none"> • Allow the oven to cool to below locking temperature.
Steam is exhausted through the oven vent.	Cooking foods with high moisture produces steam. <ul style="list-style-type: none"> • This is normal.
Appliance does not operate.	Cord is not plugged in correctly. <ul style="list-style-type: none"> • Make sure cord is plugged correctly into outlet. Check circuit breakers.
	Service wiring is not complete. <ul style="list-style-type: none"> • Contact your electrician for assistance.
	Power outage. <ul style="list-style-type: none"> • Check house lights to be sure. Call your local electric company for service.
Oven smokes excessively during grilling.	Oven is not installed properly. <ul style="list-style-type: none"> • Refer to the Installation Guide.

Symptoms	Possible Cause & Solution
Oven smokes excessively during grilling.	Meat too close to the element. <ul style="list-style-type: none"> • Reposition the rack to provide proper clearance between the meat and the element. Preheat grill element for searing.
	Meat not properly prepared. <ul style="list-style-type: none"> • Remove excess fat from meat. Cut remaining fatty edges to prevent curling.
	Grease has built up on oven surfaces. Old grease or food spatters cause excessive smoking. <ul style="list-style-type: none"> • Regular cleaning is necessary when grilling frequently.
Food does not bake or roast properly	Oven controls improperly set. <ul style="list-style-type: none"> • See the "Operating the Oven" section in the Operation chapter.
	Rack position is incorrect or the rack is not level. <ul style="list-style-type: none"> • See the "Operating the Oven" section in the Operation chapter.
	Incorrect cookware or cookware of improper size being used. <ul style="list-style-type: none"> • See the "Operating the Oven" section in the Operation chapter.
Food does not grill properly	Oven controls improperly set. <ul style="list-style-type: none"> • Make sure you select the Grill mode properly.
	Improper rack position being used. <ul style="list-style-type: none"> • See the Recommended Grilling Guide.
	Cookware not suited for grilling. <ul style="list-style-type: none"> • Use grilling pan and grid.
	In some areas the power voltage may be low. <ul style="list-style-type: none"> • Preheat the grill element for 5-7 minutes.
Moisture collects on oven window or steam comes from oven vent	This happens when cooking foods high in moisture. <ul style="list-style-type: none"> • This is normal.
	Excessive moisture was used when cleaning the window. <ul style="list-style-type: none"> • Do not use excessive moisture when cleaning the window.
Warm air venting into kitchen after oven has been turned off.	Warm air exhaust is needed to maintain and cool down oven temperatures. It turns off automatically when the heat cools to a safe temperature. <ul style="list-style-type: none"> • This is normal.
Oven will not steam cook	Improper assembly <ul style="list-style-type: none"> • Make sure to insert the water tank into correct position in the control panel.

Symptoms	Possible Cause & Solution
Oven will not steam cook	<p>The drain in the water tank may be clogged with hard water scale.</p> <ul style="list-style-type: none"> If this happens, the descaling function must be run before the steam function can be used.
Water pools in the bottom of the oven during or after steam cooking	<p>During steam cooking, the water in the water tank is transferred to the bottom of the oven.</p> <ul style="list-style-type: none"> It is normal for water to fill the bottom of the oven during or after the Steam function. If the water leaves mineral deposits on the oven bottom, remove the deposits with a cloth or sponge soaked in vinegar.
White residue appears on the oven bottom after steam cooking	<p>Using hard water in the water tank can result in hard water scale on the oven bottom.</p> <ul style="list-style-type: none"> To remove mineral deposits that remain on the oven bottom, use a cloth or sponge soaked in vinegar or a weak citric acid solution.

Parts & Features

Symptoms	Possible Cause & Solution
Oven control beeps and displays any F code error.	<p>Electronic control has detected a fault condition.</p> <ul style="list-style-type: none"> Turn off the oven function you are using to clear the display and stop the beeping. Reprogram the oven. If the fault recurs, record the fault number and call for service.
 is on in the display when you want to cook	<p>The oven door is locked because the temperature inside the oven has not dropped below the locking temperature.</p> <ul style="list-style-type: none"> Press the Start/Stop button on the control panel. Allow the oven to cool.
	<p>The Control Lock is activated</p> <ul style="list-style-type: none"> To deactivate Control Lock, refer to the Control Lock in Operation chapter.
Oven light does not work. (Model WSED7665B)	<p>It is time to replace the bulb or the bulb is loose.</p> <ul style="list-style-type: none"> Replace or tighten the bulb. See "Changing the Oven Light" in the Periodic Maintenance section.
Cooling fan continues to run after oven is turned off.	<p>The fan turns off automatically when the electronic components have cooled sufficiently.</p> <ul style="list-style-type: none"> This is normal.
Convection fan stops.	<p>Convection fan stops during a Hot Air cycle. It is done to allow more even heating during the cycle.</p> <ul style="list-style-type: none"> This is not a failure of the range and should be considered normal operation.

Noises

Symptoms	Possible Cause & Solution
"Crackling" or "popping" sound	<p>This is the sound of the metal heating and cooling during both the cooking and EasyClean functions.</p> <ul style="list-style-type: none"> This is normal.
Fan noise	<p>A convection fan may automatically turn on and off.</p> <ul style="list-style-type: none"> This is normal.

Wi-Fi

Symptoms	Possible Cause & Solution
Your home appliance and smartphone are not connected to the Wi-Fi network.	<p>The password for the Wi-Fi that you are trying to connect to is incorrect.</p> <ul style="list-style-type: none"> Find the Wi-Fi network connected to your smartphone and remove it, then register your appliance on LG ThinQ.
	<p>Mobile data for your smartphone is turned on.</p> <ul style="list-style-type: none"> Turn off the Mobile data of your smartphone and register the appliance using the Wi-Fi network.
	<p>The wireless network name (SSID) is set incorrectly.</p> <ul style="list-style-type: none"> The wireless network name (SSID) should be a combination of English letters and numbers. (Do not use special characters.)
	<p>The router frequency is not 2.4 GHz.</p> <ul style="list-style-type: none"> Only a 2.4 GHz router frequency is supported. Set the wireless router to 2.4 GHz and connect the appliance to the wireless router. To check the router frequency, check with your Internet service provider or the router manufacturer.
	<p>The distance between the appliance and the router is too far.</p> <ul style="list-style-type: none"> If the distance between the appliance and the router is too far, the signal may be weak and the connection may not be configured correctly. Move the location of the router so that it is closer to the appliance.

Customer Service & Spare Parts

Customer Service

If the fault cannot be rectified by the above measures, contact the LG Customer Information Center for service.

- If faulty, the appliance must not be used. If a fault occurs, the appliance must be isolated by removing the mains plug or switched off by removing the fuse or turning off the circuit breaker in the house fuse box.

- The appliance must only be repaired by a specially trained and qualified electrical professional. Repairs carried out improperly may result in considerable damage or injury.

CAUTION

- Repairs to the appliance must be carried out by a specially licensed technician only. Considerable danger may result from incorrect repairs.
 - Do not use the appliance if damaged. In the event of a fault or failure, switch off at the mains. In the event of a fault, visits by technicians from Customer Service or dealers may not be covered by the warranty if the cause of failure is the result of abnormal customer use.
-

Spare Parts

If you require spare parts or a technician, contact the LG Service.

- Your call will be automatically passed on to the Customer Service Centre responsible for your post code area.
- You can find the address of your local Customer Service Centre and other information for customers on the Internet at www.lg.com

Please ensure you have the following details to hand:

- Your name and address, including your post code.
- Your telephone number.
- Exact details of the nature of the problem.
- The model, series and serial number. These details are found on the rating plate located at the left-hand inner edge of the oven door.
- Your dated receipt of purchase. Please note that proof of purchase is required for any warranty claim. Before requesting a warranty claim, please ensure that you have read through the section on "TROUBLESHOOTING". There will be a charge for any inspection carried out by a technician if it should transpire that there is no mechanical or electrical fault present in the appliance.

Standby Power Consumption

COMMISSION REGULATION (EU) No 801/2013 and (EU) No 1275/2008, Applicable Standard EN 50564:2011

Standby power consumption	0.50 W
Network standby power consumption	2.00 W
The period of time after which the power management function, or a similar function, switches the equipment automatically into standby and/or off mode and/or the condition providing networked standby	5 minutes

Memo

