



# INSTALLATION MANUAL

# AIR CONDITIONER

Please read this installation manual completely before installing the product.  
Installation work must be performed in accordance with the national wiring standards  
by authorized personnel only. Please retain this installation manual for future reference  
after reading it thoroughly.

**MULTI V**<sup>inverter</sup>  
Original instruction



MFL32987320  
Rev.12\_11 1925



[www.lg.com](http://www.lg.com)

Copyright © 2017 - 2025 LG Electronics Inc. All Rights Reserved.

РУССКИЙ ЯЗЫК

ENGLISH

УКРАЇНЬСЬКА

ITALIANO

ҚАЗАҚ ТІЛІ

ESPAÑOL

БЕЛАРУСКАЯ МОВА

FRANÇAIS

ЎЗБЕК ТИЛИ

DEUTSCH

العربية

ΕΛΛΗΝΙΚΑ

ČEŠTINA

NEDERLANDS

POLSKI

LIMBA ROMÂNĂ

## TIPS FOR SAVING ENERGY

Here are some tips that will help you minimize the power consumption when you use the air conditioner. You can use your air conditioner more efficiently by referring to the instructions below:

- Do not cool excessively indoors. This may be harmful for your health and may consume more electricity.
- Block sunlight with blinds or curtains while you are operating the air conditioner.
- Keep doors or windows closed tightly while you are operating the air conditioner.
- Adjust the direction of the air flow vertically or horizontally to circulate indoor air.
- Speed up the fan to cool or warm indoor air quickly, in a short period of time.
- Open windows regularly for ventilation as the indoor air quality may deteriorate if the air conditioner is used for many hours.
- Clean the air filter once every 2 weeks. Dust and impurities collected in the air filter may block the air flow or weaken the cooling / dehumidifying functions.

### *For your records*

Staple your receipt to this page in case you need it to prove the date of purchase or for warranty purposes. Write the model number and the serial number here:

Model number : \_\_\_\_\_





Serial number : \_\_\_\_\_

You can find them on a label on the side of each unit.

Dealer's name : \_\_\_\_\_

Date of purchase : \_\_\_\_\_

# SAFETY INSTRUCTIONS

	Read the precautions in this manual carefully before operating the unit.		This appliance is filled with flammable refrigerant. (for R32)
	This symbol indicates that the Operation Manual should be read carefully.		This symbol indicates that a service personnel should be handling this equipment with reference to the Installation Manual.

The following safety guidelines are intended to prevent unforeseen risks or damage from unsafe or incorrect operation of the appliance.

The guidelines are separated into 'WARNING' and 'CAUTION' as described below.

 This symbol is displayed to indicate matters and operations that can cause risk.  
Read the part with this symbol carefully and follow the instructions in order to avoid risk.

## WARNING

This indicates that the failure to follow the instructions can cause serious injury or death.

## CAUTION

This indicates that the failure to follow the instructions can cause the minor injury or damage to the product.

## WARNING

### Installation

- Installation or repairs made by unqualified persons can result in hazards to you and others.
- The information contained in the manual is intended for use by a qualified service technician familiar with safety procedures and equipped with the proper tools and test instruments.
- Failure to carefully read and follow all instructions in this manual can result in equipment malfunction, property damage, personal injury and/or death.

- The appliance shall be installed in accordance with the national wiring regulation.
- Compliance with national gas regulations shall be observed.
- Have all electric work done by a licensed electrician according to "Electric Facility Engineering Standard" and "Interior Wire Regulations" and the instructions given in this manual and always use a special circuit.
  - If the power source capacity is inadequate or electric work is performed improperly, electric shock or fire may result.
- Ask the dealer or an authorized technician to install the HR unit.
  - Improper installation by the user may result in water leakage, electric shock, or fire.
- Always ground the product.
  - There is risk of fire or electric shock.
- Make the connections securely so that the outside force of the cable may not be applied to the terminals.
  - Inadequate connection and fastening may generate heat and cause a fire.
- For re-installation of the installed product, always contact a dealer or an Authorized Service Center.
  - There is risk of fire, electric shock, explosion, or injury.
- Do not install, remove, or re-install the unit by yourself (customer).
  - There is risk of fire, electric shock, explosion, or injury.
- Use the correctly rated breaker or fuse.
  - There is risk of fire or electric shock.
- Do not damage or use an unspecified power cord.
  - There is risk of fire, electric shock, explosion, or injury.
- Securely install the cover of control box and the panel.
  - If the cover and panel are not installed securely, dust or water may enter the HR unit and fire or electric shock may result.
- Be cautious when unpacking and installing the product.
  - Sharp edges could cause injury. Be especially careful of the case edges.
- Safely dispose of the packing materials.
  - Packing materials, such as nails and other metal or wooden parts, may cause stabs or other injuries.
  - Tear apart and throw away plastic packaging bags so that children may not play with them. If children play with a plastic bag which was not torn apart, they face the risk of suffocation.

- Mechanical connections shall be accessible for maintenance purposes.
- When mechanical connectors are reused indoors, sealing parts shall be renewed. (for R32)
- When flared joints are reused indoors, the flare part shall be re-fabricated. (for R32)
- Be aware that refrigerants may not contain an odour.

## Operation

- Do not store or use flammable gas or combustibles near the HR Unit.
  - There is risk of fire or failure of product.
- Do not touch the power switch with wet hands.
  - There is risk of fire, electric shock, explosion, or injury.
- Keep any required ventilation openings clear of obstruction.
- Do not use means to accelerate the defrosting process or to clean, other than those recommended by the manufacturer.
- Do not pierce or burn refrigerant cycle part.

## CAUTION

### Installation

- Do not install a HR unit in a space where persons exists such as living room, office or meeting room with not only low but also open ceiling.
- Always check for gas (refrigerant) leakage after installation or repair of product.
  - Low refrigerant levels may cause failure of product.
- Keep level even when installing the product.
  - To avoid vibration or water leakage.
- Means for disconnection must be incorporated in the fixed wiring in accordance with the wiring rules.
- Any person who is involved with working on or breaking into a refrigerant circuit should hold a current valid certificate from an industry accredited assessment authority, which authorizes their competence to handle refrigerants safely in accordance with an industry recognized assessment specification. (for R32)
- The installation of pipe-work shall be kept to a minimum.
- Pipe-work shall be protected from physical damage.

- A brazed, welded, or mechanical connection shall be made before opening the valves to permit refrigerant to flow between the refrigerating system parts.
- Dismantling the unit, treatment of the refrigerant oil and eventual parts should be done in accordance with local and national standards.
- Servicing shall only be performed as recommended by the equipment manufacturer. Maintenance and repair requiring the assistance of other skilled personnel shall be carried out under the supervision of the person competent in the use of flammable refrigerants. (for R32)
- Do not install the unit in potentially explosive atmospheres.
- (Australia only) This product must be installed by a professional installer.
- After the installation of the product in the customer premises, fully remove all product packaging (including any expanded or moulded plastic packaging materials) and recycle or dispose of such packaging responsibly. Do not dispose any expanded plastic packaging in the household bin.

### Operation

- Avoid a place where rain may enter since the HR unit is for indoor.
  - There is risk of property damage, failure of product, or electric shock.
- This appliance is not intended for use by persons (including children) with reduced physical, sensory or mental capabilities or lack of experience and knowledge, unless they have been given supervision or instruction concerning use of the appliance by a person responsible for their safety.
  - Children should be supervised to ensure that they do not play with the appliance.
- The appliance shall be stored so as to prevent mechanical damage from occurring.
- Refrigerant tubing shall be protected or enclosed to avoid damage.
- Flexible refrigerant connectors (such as connecting lines between the indoor and outdoor unit) that may be displaced during normal operations shall be protected against mechanical damage.
- If the supply cord is damaged, it must be replaced by the manufacturer, its service agent or similarly qualified persons in order to avoid a hazard.
- To prevent the mixing of different types of refrigerants, be sure to check the type of refrigerant used in the outdoor unit.

---

# TABLE OF CONTENTS

## 2 TIPS FOR SAVING ENERGY

---

## 3 SAFETY INSTRUCTIONS

---

## 8 FEATURES

---

## 10 INSTALLATION PART

---

11 Dimensional drawings

## 11 INSTALLATION

---

11 Selection of the best location

15 HR Unit Installation

16 Connecting the Strainer

20 Insulation

21 Wiring Connection

22 Electric Characteristics

23 HR Unit PCB

24 Setup the switch of HR Unit

## 31 COIL EXCHANGING METHOD

---

## 32 JOINT METHOD OF HR UNIT

---

## FEATURES

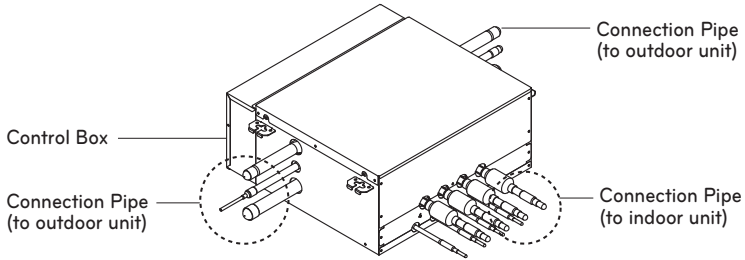

Type of HR unit		2 port HR unit	3 port HR unit	4 port HR unit	
Max. Connectable No. of Indoor Units		16	24	32	
Max. Connectable No. of Indoor Units of a branch		8	8	8	
Nominal Input	Cooling [W]	39.8			
	Heating [W]	37.2			
Net. Weight	kg	15.1	17.1	18.7	
	lbs	33.3	37.7	41.2	
Dimensions (WxHxD)	mm	786 X 218 X 688			
	Inch	30.9 X 8.6 X 27.1			
Casing		Galvanized steel plate			
Connecting Pipes	Indoor side	Liquid Pipe [mm]	Ø 9.52 – Ø 6.35		
		Gas Pipe [mm]	Ø 15.88 – Ø 12.7		
	Outdoor side	Liquid [mm]	Ø 9.52	Ø 12.7	Ø 15.88
		Low Pressure [mm]	Ø 22.2	Ø 28.58	Ø 28.58
		High Pressure [mm]	Ø 19.05	Ø 22.2	Ø 22.2
Sound Absorbing Insulation Material		Polyethylene Foam			
Current	Minimum circuit Amps(MCA)	0.17			
	Maximum fuse Amps(MFA)	15			
Power Supply		220-240 V~ 50/60 Hz			

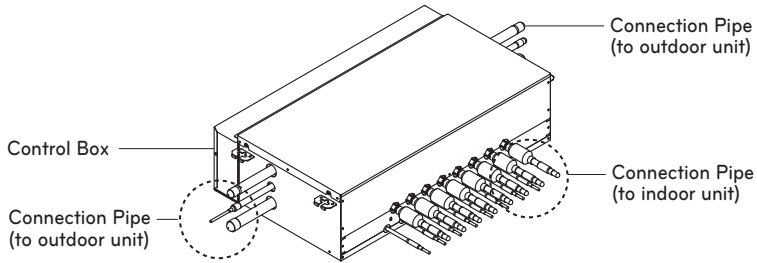



Type of HR unit		6 port HR unit	8 port HR unit
Max. Connectable No. of Indoor Units		48	64
Max. Connectable No. of Indoor Units of a branch		8	8
Nominal Input	Cooling [W]	75.9	
	Heating [W]	72.1	
Net. Weight	kg	28	31.7
	lbs	61.7	69.9
Dimensions (WxHxD)	mm	1 113 X 218 X 688	
	Inch	43.8 X 8.6 X 27.1	
Casing		Galvanized steel plate	
Connecting Pipes	Indoor side	Liquid Pipe [mm]	Ø 9.52 – Ø 6.35
		Gas Pipe [mm]	Ø 15.88 – Ø 12.7
	Outdoor side	Liquid [mm]	Ø 15.88
		Low Pressure [mm]	Ø 28.58
		High Pressure [mm]	Ø 22.2
Sound Absorbing Insulation Material		Polyethylene Foam	
Current	Minimum circuit Amps(MCA)	0.27	
	Maximum fuse Amps(MFA)	15	
Power Supply		220-240 V ~ 50/60 Hz	

# INSTALLATION PART

- Installation Manual
- Hanging bolts (4 x M10 or M8), Nut(8 x M10 or M8), Flat washers(8 x M10)
- Reducers

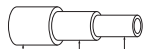
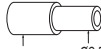
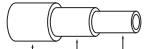
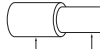
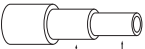
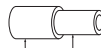
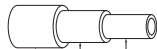
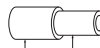
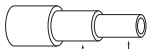
[Unit : mm(inch)]

Type of HR unit		Liquid pipe	Gas pipe	
			High pressure	Low pressure
HR unit reducer	2 port	 <p>OD9.52(3/8) Ø6.35(1/4)</p>	 <p>OD19.05(3/4) Ø15.88(5/8) Ø12.7(1/2)</p>  <p>OD12.7(1/2) Ø9.52(3/8)</p>	 <p>OD22.2(7/8) Ø19.05(3/4) Ø15.88(5/8)</p>  <p>OD15.88(5/8) Ø12.7(1/2)</p>
	3 port/ 4 port/ 6 port/ 8 port	 <p>OD15.88(5/8) Ø12.7(1/2) Ø9.52(3/8)</p>  <p>OD12.7(1/2) Ø9.52(3/8)</p>	 <p>OD22.2(7/8) Ø19.05(3/4) Ø15.88(5/8)</p>  <p>OD15.88(5/8) Ø12.7(1/2)</p>	 <p>OD28.58(1-1/8) Ø22.2(7/8) Ø19.05(3/4)</p>  <p>OD19.05(3/4) Ø15.88(5/8)</p>

Models		High pressure gas pipe
Strainer	3 port/ 4 port/ 6 port/ 8 port	

\* For more information, refer accessory installation manual.

# INSTALLATION

## Selection of the best location

Select installation location of the HR unit suitable for following conditions

- Avoid a place where rain may enter since the HR unit is for indoor.
- Sufficient service space must be obtained.
- Refrigerant pipe must not exceed limited length.
- Avoid a place subject to a strong radiation heat from other heat source.
- Avoid a place where high humidity over 80%, oil spattering, vapor spray or high frequency electric noise is expected.
- Install the unit at a place in which it is not affected by operation noise. (Installation within cell such as meeting room etc. may disturb business due to noise.)
- Place where refrigerant piping, drain piping and electrical wiring works are easy.

## Dimensional drawings

### 2 port / 3port / 4port HR unit

\*Connect the strainer to the HR unit directly.

1 Parallel connection with the HR unit. (Except PRHR023)

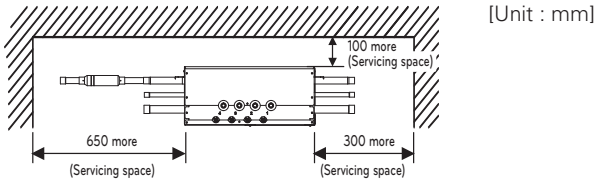

2 Serial connection with the HR unit. (Except PRHR023)

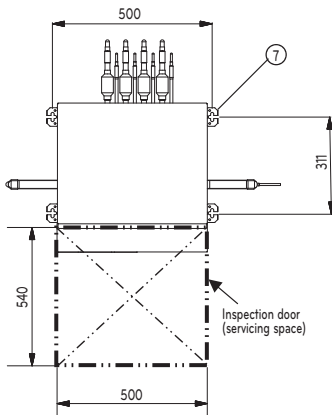

[Unit : mm]

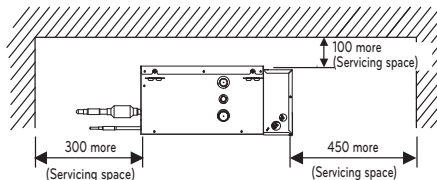
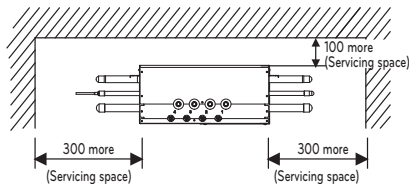

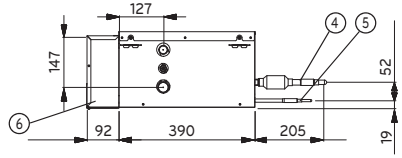
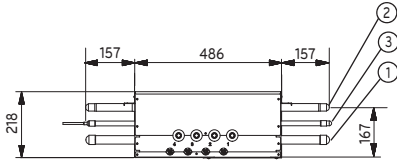

**6 port / 8 port HR unit**

\*Connect the strainer to the HR unit directly

1 Parallel connection with the HR unit.

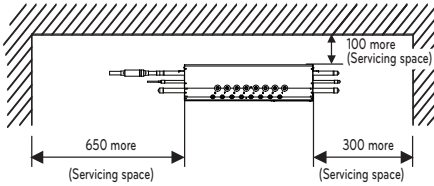

[Unit : mm]

2 Serial connection with the HR unit.

[Unit : mm]

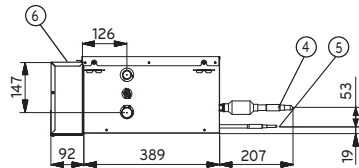
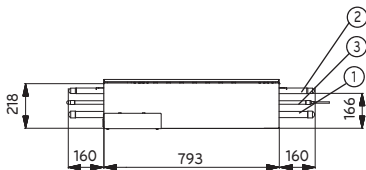
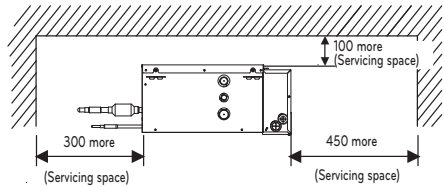
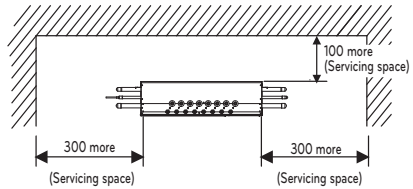
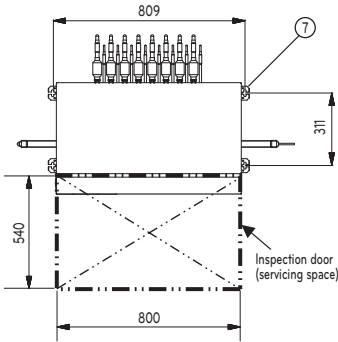

No.	Part Name	Type of HR unit	
		3 port / 4 port 6 port / 8 port	2 port
		Description	
1	Low pressure Gas pipe connection port	Ø 28.58 Brazing connection	Ø 22.2 Brazing connection
2	High pressure Gas pipe connection port	Ø 22.2 Brazing connection	Ø 19.05 Brazing connection
3	Liquid pipe connection port	Ø 15.88 Brazing connection (In a type of 3 port HR unit, use Ø12.7)	Ø 9.52 Brazing connection
4	Indoor unit Gas pipe connection port	Ø 15.88 – Ø 12.7 Brazing connection	Ø 15.88 – Ø 12.7 Brazing connection
5	Indoor unit Liquid pipe connection port	Ø 9.52 – Ø6 .35 Brazing connection	Ø 9.52 – Ø 6.35 Brazing connection
6	Control box	-	-
7	Hanger metal	Suspension bolt M10 or M8	Suspension bolt M10 or M8

**NOTE**

\* Be sure to install the inspection door at the electric control side.

\*\* If reducers are used, servicing space must be increased equal to reducer's dimension.

### Minimum floor area (for R32)

- The appliance shall be installed, operated and stored in a room with a floor area larger than the minimum area.
- Use the graph of table to determine the minimum area.

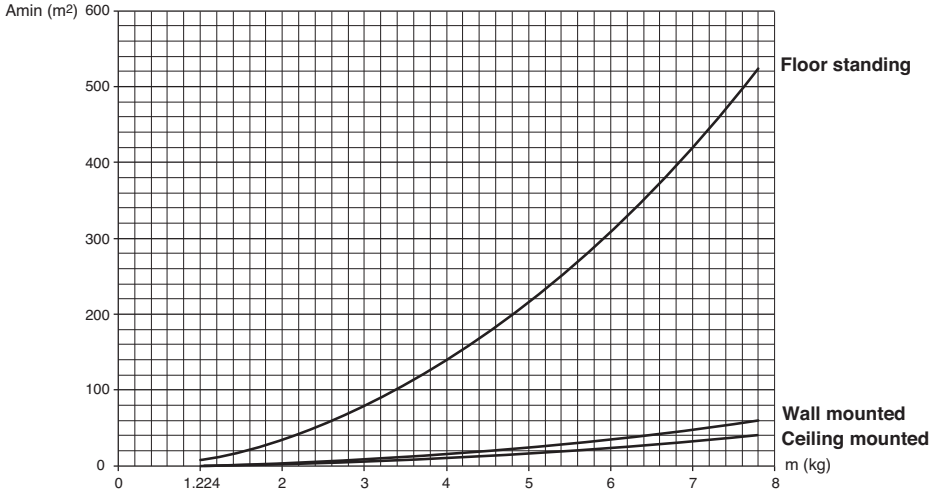

- m : Total refrigerant amount in the system
- Total refrigerant amount : factory refrigerant charge + additional refrigerant amount
- Amin : minimum area for installation

Floor location		Floor location	
m (kg)	Amin (m <sup>2</sup> )	m (kg)	Amin (m <sup>2</sup> )
< 1.224	-	4.6	181.56
1.224	12.9	4.8	197.70
1.4	16.82	5	214.51
1.6	21.97	5.2	232.02
1.8	27.80	5.4	250.21
2	34.32	5.6	269.09
2.2	41.53	5.8	288.65
2.4	49.42	6	308.90
2.6	58.00	6.2	329.84
2.8	67.27	6.4	351.46
3	77.22	6.6	373.77
3.2	87.86	6.8	396.76
3.4	99.19	7	420.45
3.6	111.20	7.2	444.81
3.8	123.90	7.4	469.87
4	137.29	7.6	495.61
4.2	151.36	7.8	522.04
4.4	166.12		

Wall mounted		Wall mounted	
m (kg)	Amin (m <sup>2</sup> )	m (kg)	Amin (m <sup>2</sup> )
< 1.224	-	4.6	20.17
1.224	1.43	4.8	21.97
1.4	1.87	5	23.83
1.6	2.44	5.2	25.78
1.8	3.09	5.4	27.80
2	3.81	5.6	29.90
2.2	4.61	5.8	32.07
2.4	5.49	6	34.32
2.6	6.44	6.2	36.65
2.8	7.47	6.4	39.05
3	8.58	6.6	41.53
3.2	9.76	6.8	44.08
3.4	11.02	7	46.72
3.6	12.36	7.2	49.42
3.8	13.77	7.4	52.21
4	15.25	7.6	55.07
4.2	16.82	7.8	58.00
4.4	18.46		

Ceiling Mounted		Ceiling Mounted	
m (kg)	Amin (m <sup>2</sup> )	m (kg)	Amin (m <sup>2</sup> )
< 1.224	-	4.6	13.50
1.224	0.956	4.8	14.70
1.4	1.25	5	15.96
1.6	1.63	5.2	17.26
1.8	2.07	5.4	18.61
2	2.55	5.6	20.01
2.2	3.09	5.8	21.47
2.4	3.68	6	22.98
2.6	4.31	6.2	24.53
2.8	5.00	6.4	26.14
3	5.74	6.6	27.80
3.2	6.54	6.8	29.51
3.4	7.38	7	31.27
3.6	8.27	7.2	33.09
3.8	9.22	7.4	34.95
4	10.21	7.6	36.86
4.2	11.26	7.8	38.83
4.4	12.36		

Ceiling Mounted		Ceiling Mounted	
m (kg)	Amin (m <sup>2</sup> )	m (kg)	Amin (m <sup>2</sup> )
< 1.224	-	4.6	13.50
1.224	0.956	4.8	14.70
1.4	1.25	5	15.96
1.6	1.63	5.2	17.26
1.8	2.07	5.4	18.61
2	2.55	5.6	20.01
2.2	3.09	5.8	21.47
2.4	3.68	6	22.98
2.6	4.31	6.2	24.53
2.8	5.00	6.4	26.14
3	5.74	6.6	27.80
3.2	6.54	6.8	29.51
3.4	7.38	7	31.27
3.6	8.27	7.2	33.09
3.8	9.22	7.4	34.95
4	10.21	7.6	36.86
4.2	11.26	7.8	38.83
4.4	12.36		

Ceiling Mounted		Ceiling Mounted	
m (kg)	Amin (m <sup>2</sup> )	m (kg)	Amin (m <sup>2</sup> )
< 1.224	-	4.6	13.50
1.224	0.956	4.8	14.70
1.4	1.25	5	15.96
1.6	1.63	5.2	17.26
1.8	2.07	5.4	18.61
2	2.55	5.6	20.01
2.2	3.09	5.8	21.47
2.4	3.68	6	22.98
2.6	4.31	6.2	24.53
2.8	5.00	6.4	26.14
3	5.74	6.6	27.80
3.2	6.54	6.8	29.51
3.4	7.38	7	31.27
3.6	8.27	7.2	33.09
3.8	9.22	7.4	34.95
4	10.21	7.6	36.86
4.2	11.26	7.8	38.83
4.4	12.36		

## HR Unit Installation

- Select and mark the position for fixing bolts.
- Drill the hole for set anchor on the face of ceiling.

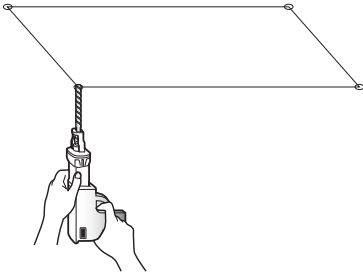

### ⚠ WARNING

Tighten the nut and bolt to prevent unit falling.

- Insert the set anchor and washer onto the suspension bolts for locking the suspension bolts on the ceiling.
- Mount the suspension bolts to the set anchor firmly.
- Secure the installation plates onto the suspension bolts (adjust level roughly) using nuts, washers and spring washers.

- 1 Using an insert-hole-in- anchor, hang the suspension bolt.
- 2 Install a six-sided nut and a flat washer (locally-procured)to the suspension bolt as shown in the figure in the bottom, and fit the main unit to hang on the hanger metal.
- 3 After checking with a level that the unit is level, tighten the hexagon nut.  
\* The tilt of the unit should be within  $\pm 5^\circ$  in front/back and left/right.
- 4 This unit should be installed suspended from ceiling and side A should always be facing up.

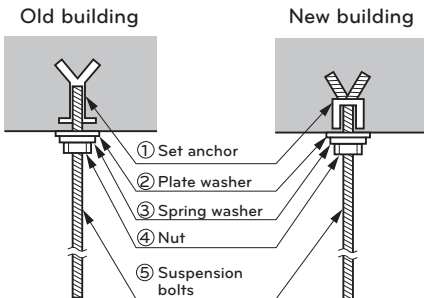
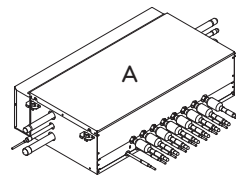
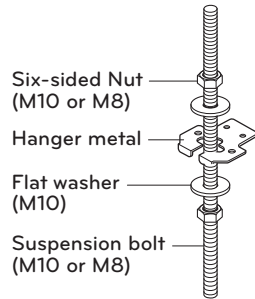

## Connecting the Strainer

- Connect the strainer to the HR unit directly.

If there is not enough space to install the strainer, install it between the outdoor unit and the HR unit connection pipe. The distance between the strainer and the HR unit should be within 3 m.

### 1 Parallel connection with the HR unit (Except PRHR023)

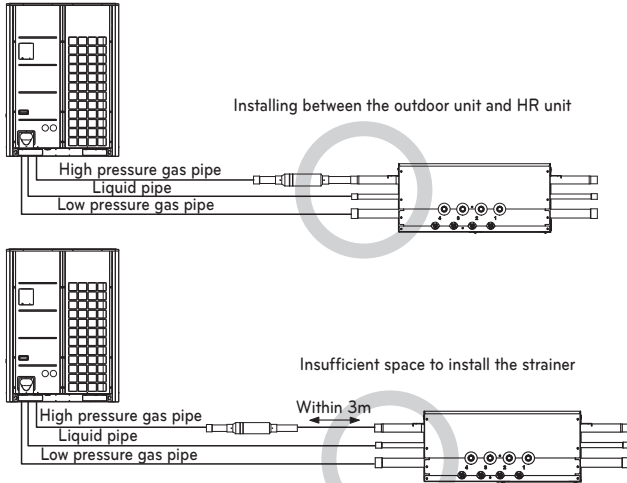

### 2 Serial connection with the HR unit (Except PRHR023)

- When connecting the HR unit in a series, the first strainer is mounted between the outdoor unit and the HR unit, and the next strainer is mounted between the previous HR unit and the next HR unit.

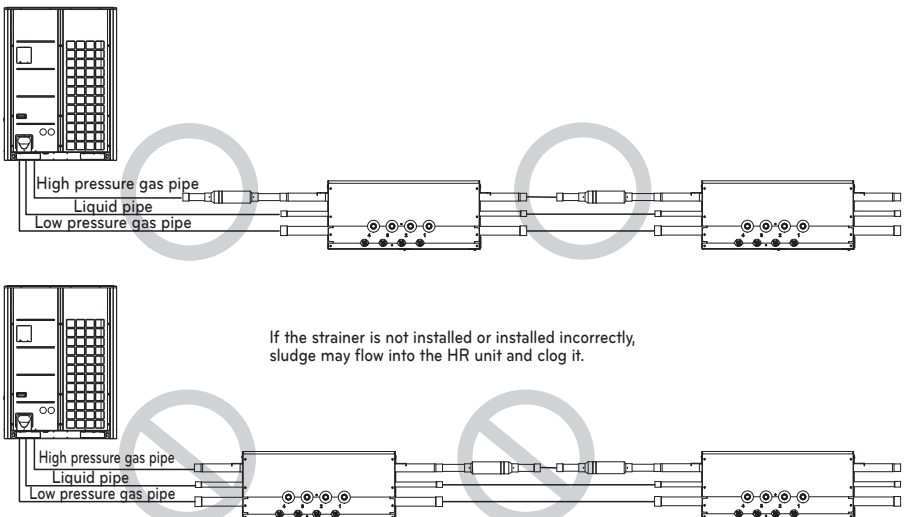

## ⚠ CAUTION

HR Unit should be installed that top side is facing up. If not, it may cause failure of the product.

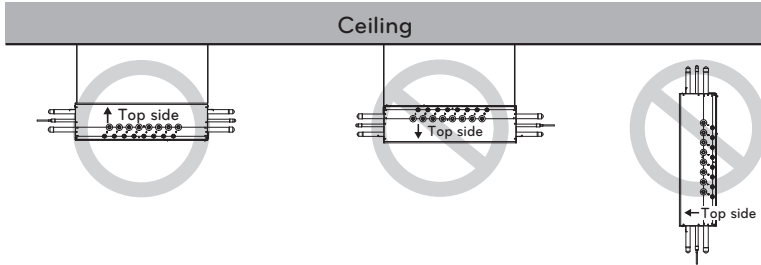

## ⚠ WARNING

Before brazing work, remove gas in the HR Unit by cutting the three pipes in the small circles on the figure. If not, it may cause injuries. Remove the caps before connecting pipes.

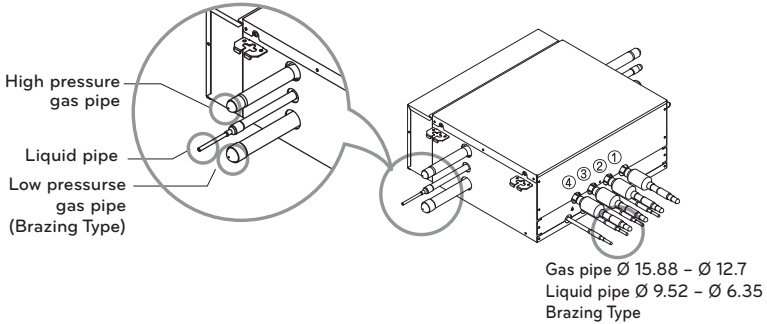

Connect after removing the cap.

Connect the strainer which is provided as an accessory to the HR unit's high pressure gas pipe.

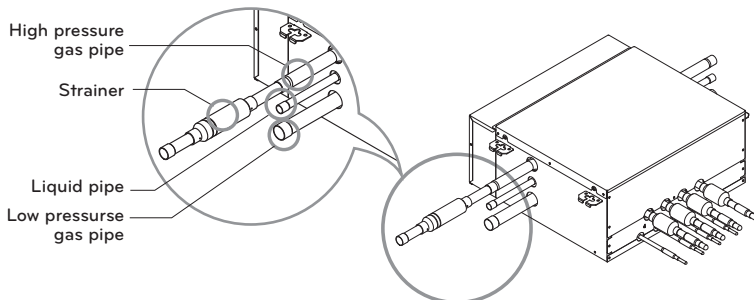

After considering the indoor unit capacity, determine the pipe sizes and cut the pipes connected to the indoor unit.

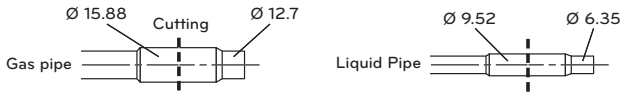

## ! CAUTION

- Whenever connecting the indoor units with the HR unit, install the indoor units in numerical order from No.1.  
Ex) In case of installing 3 indoor units : No. 1, 2, 3 (O), No. 1, 2, 4 (X), No.1, 3, 4 (X), No.2, 3, 4 (X).
- Take care of no thermal damage on the valves of the HR unit.  
(Especially packing part of valve)  
Wrap the valve with a wet towel when brazing it.

## IMPORTANT!

### Please read this instruction sheet completely before installing the product.

This air conditioning system meets strict safety and operating standards. As the installer or service person, it is an important part of your job to install or service the system so it operates safely and efficiently.

## WARNING

- Installation or repairs made by unqualified persons can result in hazards to you and others. Installation of all field wiring and components **MUST** conform with local building codes or, in the absence of local codes, with the National Electrical Code 70 and the National Building Construction and Safety Code or Canadian Electrical code and National Building Code of Canada.
- The information contained in the manual is intended for use by a qualified service technician familiar with safety procedures and equipped with the proper tools and test instruments.
- Failure to carefully read and follow all instructions in this manual can result in equipment malfunction, property damage, personal injury and/or death.

**CAUTION** : Improper installation, adjustment, alteration, service or maintenance can void the warranty.

The weight of the condensing unit requires caution and proper handling procedures when lifting or moving to avoid personal injury. Use care to avoid contact with sharp or pointed edges.

### Safety Precautions

- Always wear safety eye wear and work gloves when installing equipment.
- Never assume electrical power is disconnected. Check with meter and equipment.
- Keep hands out of fan areas when power is connected to equipment.
- R-410A causes frostbite burns.
- R-410A is toxic when burned.

**NOTE TO INSTALLING DEALER** : The Owners Instructions and Warranty are to be given to the owner or prominently displayed near the indoor Furnace/Air Handler Unit.

## WARNING

### When wiring:

Electrical shock can cause severe personal injury or death. Only a qualified, experienced electrician should attempt to wire this system.

- Do not supply power to the unit until all wiring and tubing are completed or reconnected and checked.
- Highly dangerous electrical voltages are used in this system. Carefully refer to the wiring diagram and these instructions when wiring. Improper connections and inadequate grounding can cause accidental injury or death.
- Ground the unit following local electrical codes.
- Connect all wiring tightly. Loose wiring may cause overheating at connection points and a possible fire hazard.
- The choice of materials and installations must comply with the applicable local/national or international standards.
- Connect the power/communication wire with Double insulation or Reinforced insulation at reachable place.

### When transporting:

Be careful when picking up and moving the indoor and outdoor units. Get a partner to help, and bend your knees when lifting to reduce strain on your back. Sharp edges or thin aluminum fins on the air conditioner can cut your finger.

### When installing...

... in a wall: Make sure the wall is strong enough to hold the unit's weight.

It may be necessary to construct a strong wood or metal frame to provide added support.

... in a room: Properly insulate any tubing run inside a room to prevent "sweating" that can cause dripping and water damage to wall and floors.

... in moist or uneven locations: Use a raised concrete pad or concrete blocks provide a solid, level foundation for the outdoor unit. This prevents water damage and abnormal vibration.

... in an area with high winds: Securely anchor the outdoor unit down with bolts and a metal frame. Provide a suitable air baffle.

... in a snowy area(for Heat Pump Model): Install the outdoor unit on a raised platform that is higher than drifting snow. Provide snow vents.

### When connecting refrigerant tubing

- Keep all tubing runs as short as possible.
- Use the flare method for connecting tubing.
- Check carefully for leaks before starting the test run.

### When servicing

- Turn the power OFF at the main power box(mains) before opening the unit to check or repair electrical parts and wiring.
- Keep your fingers and clothing away from any moving parts.
- Clean up the site after you finish, remembering to check that no metal scraps or bits of wiring have been left inside the unit being serviced.

## Insulation

Insulate the connected pipes completely(all thermal insulation must comply with local requirement)

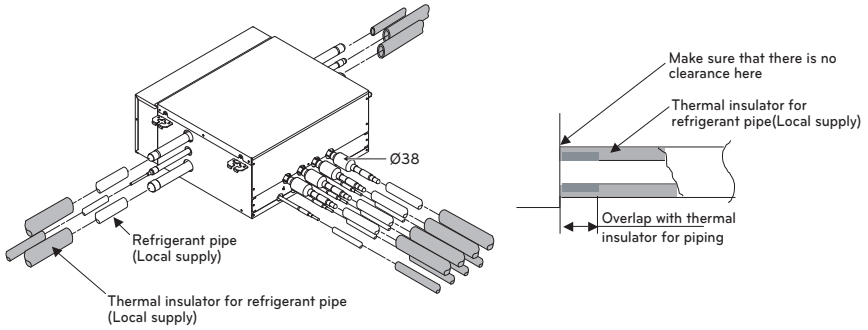

## ! CAUTION

Insulate completely unconnected pipes as shown in the Figure.

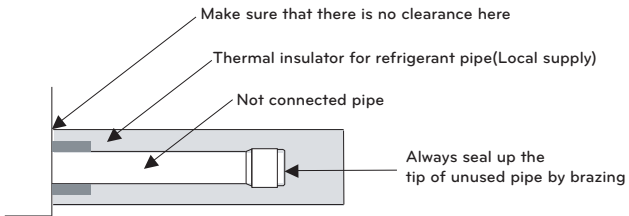

## Wiring Connection

Connect the wires to the terminals on the control board individually according to the outdoor unit connection.

- Ensure that the color of the wires of outdoor unit and the terminal No. are the same as those of HR Unit respectively.
- The installation of a residual current device (RCD) having a rated residual operating current not exceeding 30 mA is advisable.

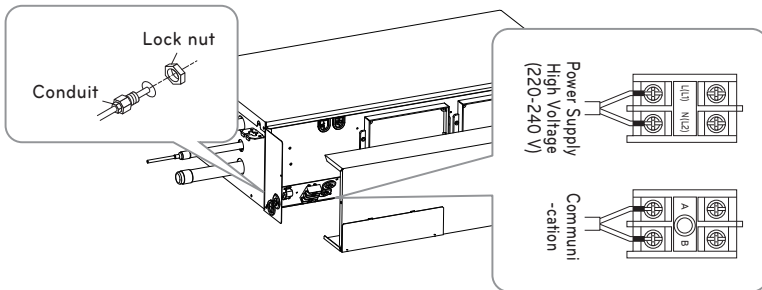
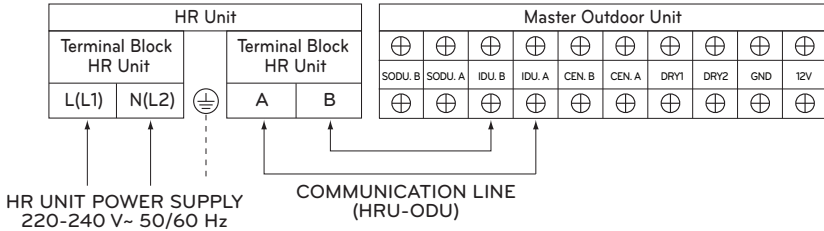

## Electric Characteristics

- Recommended circuit breaker is ELCB
- MFA is used to select the circuit breaker and ground fault circuit interrupter
- Refer to the PDB about detail electric characteristics

ELCB : Earth Leakage Circuit Breaker  
 MFA : Maximum Fuse Amperes(A)  
 PDB : Product Data Book

### CAUTION

- The connecting cable connected to the indoor and outdoor unit should be complied with the following specifications (Rubber insulation, type H05RN-F approved by HAR or SAA).

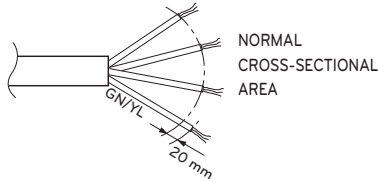

Rated current of appliance A.	Nominal cross-sectional area mm <sup>2</sup>
≤ 0.2	Tinsel cord
> 0.2 and ≤ 3	0.5
> 3 and ≤ 6	0.75
> 6 and ≤ 10	1.0 (0.75)
> 10 and ≤ 16	1.5 (1.0)
> 16 and ≤ 25	2.5
> 25 and ≤ 32	4
> 32 and ≤ 40	6
> 40 and ≤ 63	10

- If the supply cord is damaged, it must be replaced by a special cord or assembly available from the manufacturer of its service agent.
- Pipes and wires should be purchased separately for installation of the product.

### WARNING

Loose wiring may cause the terminal to overheat or result in unit malfunction.  
 A fire hazard may also exist.  
 Therefore, be sure all wiring is tightly connected.

### WARNING

Make sure that the screws of the terminal are free from looseness.

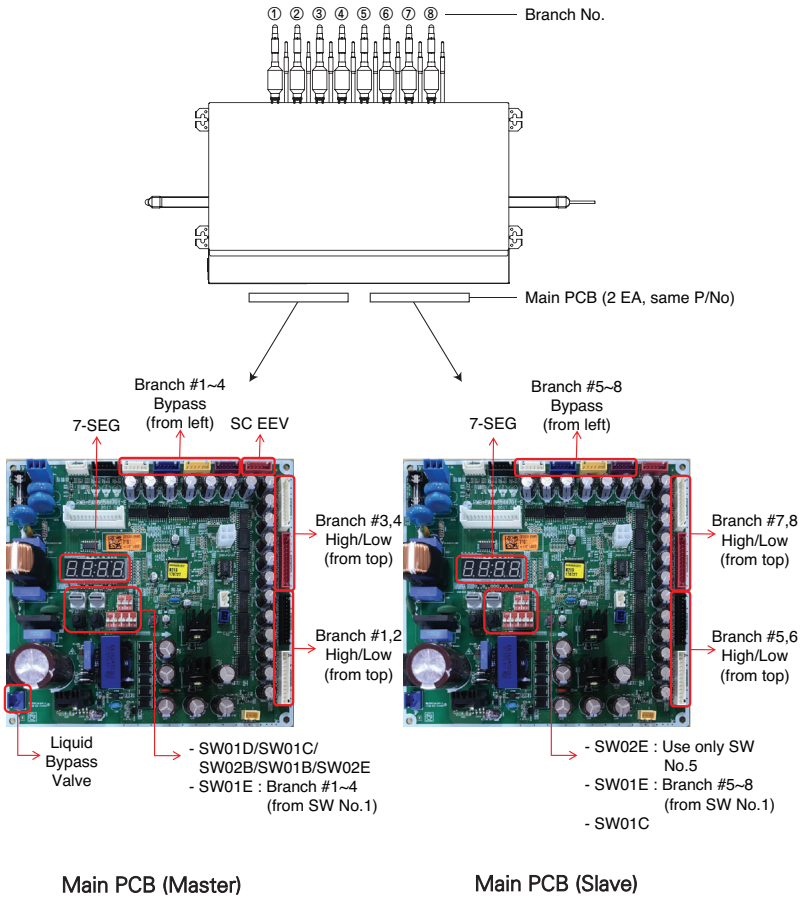

# HR Unit PCB



\* Number from left in sequence for less-than-8 branch model.

\*\* 2 port / 3 port / 4 port HR unit : Mater only

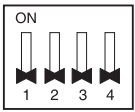
## Setup the switch of HR Unit

	SW		Function
DIP SW		SW02E (8 pin DIP SW)	Selection of the method for pipe detection Selection of Master/Slave Main PCB Setting the Zoning Control Selection of the No. of connected branches
		SW01E (4 pin DIP SW)	Selection of the valve to address
Rotary SW		SW01D (Left)	Selection of the Valve Group Control
		SW01C (Right)	Manual addressing of zoning indoor units Setting to address HR units
Push SW		SW02B (Left)	Increase in the digit of 10
		SW01B (Right)	Increase in the digit of 1

### Main function of SW02E

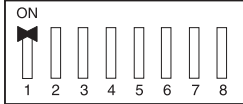

ON S/W	Selection	
No.1	Method for pipe detection of an HR Unit (Auto/Manual)	
No.2	No. of connected branches	
No.3		
No.4		
No.5	Master/Slave (Main PCB) Setting	
No.6	EEPROM factory initialization (4, 5, 6)	
No.7	Use only in factory production (preset to "OFF")	Zoning setting ("ON")
No.8	Use only in factory production (preset to "OFF")	

1) Selection of the method for pipe detection of an HR unit (Auto/Manual)

Auto	Manual
<p style="text-align: center;">Switch No.1 Off</p> <p style="text-align: center;"><b>Master</b></p> 	<p style="text-align: center;">Switch No.1 On</p> <p style="text-align: center;"><b>Master</b></p> 

\* Master Only

2) Selection of Master/Slave Main PCB

Master	Slave
<p style="text-align: center;">Switch No.5 Off</p> 	<p style="text-align: center;">Switch No.5 On</p> 

**NOTE**



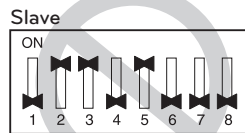



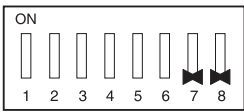
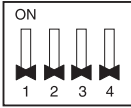
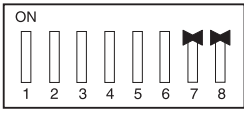
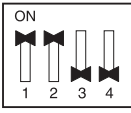

Do not turn on any SW02E on Slave Main PCB except No.5.



3) Setting the zoning control

	SW02E setting	SW01E setting
Normal control	<p>* Master Only</p> <p><b>Master</b></p> 	 <p><b>SW01E</b></p>
Zoning control	<p>* Master Only</p> <p><b>Master</b></p> 	<p><b>Master</b></p>  <p><b>SW01E</b></p> <p>Turn the DIP switch of the zoning branch on. EX) Branch 1,2 are zoning control.</p>

4) Selection of the No. of connected branches

1 branch Connected		5 branch Connected	
2 branches Connected		6 branch Connected	
3 branches Connected		7 branch Connected	
4 branches Connected		8 branch Connected	

\* Master Only

**! WARNING**

If you want to use a "Model" for "No. of using branch(es)" HR Unit after closing the "Closing pipe No.", set the DIP switch for "No. of using branch(es)" HR Unit.

Ex) If you want to use a type of 8 port HR unit for 4 branches HR Unit after closing the 5~8th pipes, set the DIP switch for 4 branches HR Unit.



### SW01C (Rotary S/W for addressing HR unit)

Must be set to '0' when installing only one HR unit.

When installing multiple HR units, address the HR units with sequentially increasing numbers starting from '0'.

Maximum 16 HR Units can be installed.



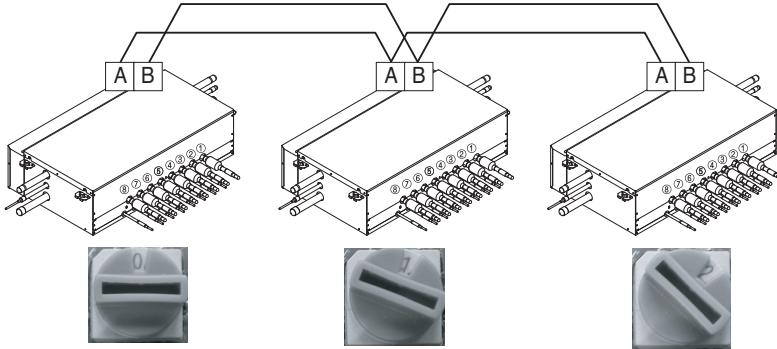

Ex) Installation of 3 HR units

\* Master Only

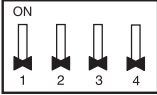

### SW01B/SW01C/SW01E/SW02B (DIP S/W and push S/W for Manual pipe detection)

- Set the address of the valve of the HR unit to the central control address of the connected indoor unit.
- SW01E: selection of the valve to address
- SW02B: increase in the digit of 10 of valve address
- SW01B: increase in the last digit of valve address
- SW01C: Manual addressing of zoning indoor units (use for Zoning setting)
- Prerequisite for Manual pipe detection : central control address of each indoor unit must be preset differently at its wired remote control.

	S/W No.	Setup
 SW01E	No.1	Manual addressing of valve #1 (Master) / #5 (Slave)
	No.2	Manual addressing of valve #2 (Master) / #6 (Slave)
	No.3	Manual addressing of valve #3 (Master) / #7 (Slave)
	No.4	Manual addressing of valve #4 (Master) / #8 (Slave)
	SW02B	Increase in the digit of 10 of valve address
	SW01B	Increase in the last digit of valve address
* Use for Zoning setting 	SW01C	Manual addressing of zoning indoor units

1) Normal setting (Non-Zoning setting)

ex) Manual pipe detection of Valve #1, 6.

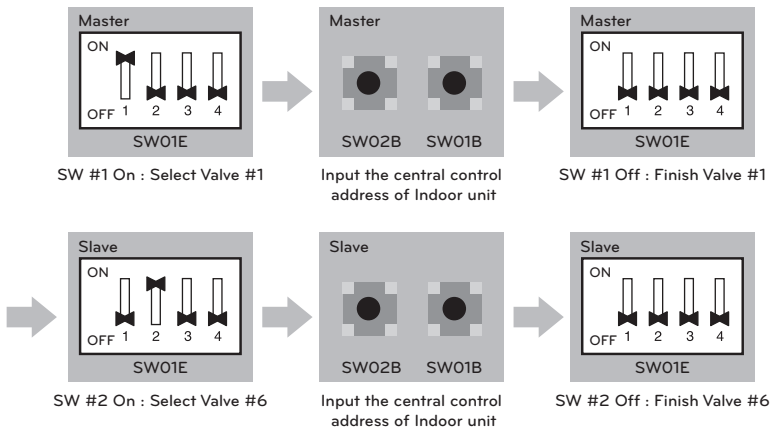

2) Zoning setting

**NOTE**

Use the Zoning Control when install two or more indoor units at 1 branch of HR Unit. The indoor units controlled by Zoning Control can be selected collectively as the cooling/heating mode.

ex) Manual pipe detection of Valve #5 with three zoning indoor units, #6 without zoning unit.

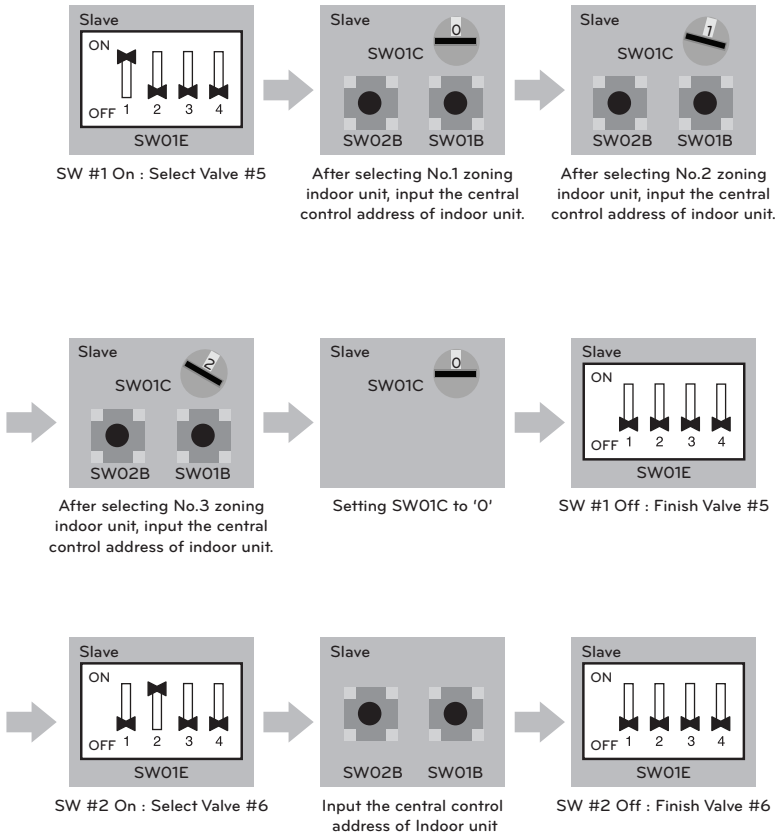

# COIL EXCHANGING METHOD

- 1 Remove the 2 securing screws.  
Remove the cover by pulling on the bottom of the cover and lifting up.
- 2 Remove the 6 securing screws.  
Lift up and pull on the cover.

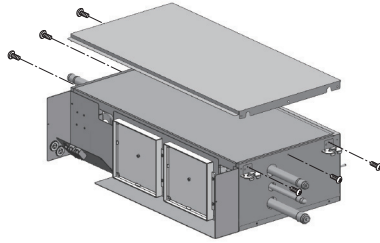
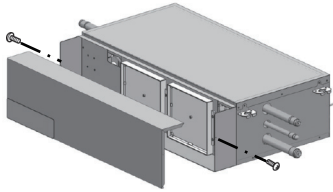

- 3 Lift up and pull on the insulator.
- 4 Exchange the coil.

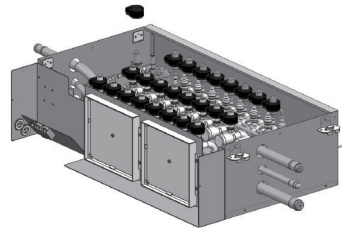
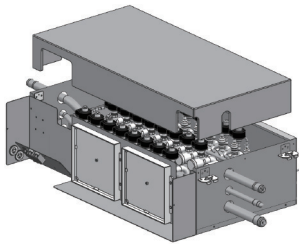

## NOTE

Be sure that system power off before exchanging the coil.  
Check the position of the valve coil with the label attached on the cover inside when abnormal noise is heard loudly during operation.

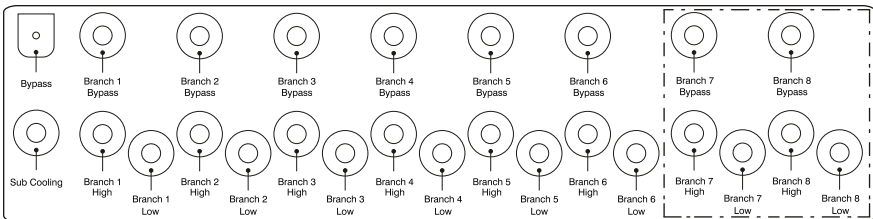

Position label of the valve coil of a type of 8 port HR unit

# JOINT METHOD OF HR UNIT

Joint Method is required when use indoor unit that exceed 61 kbtu is installed. In Joint Method, two neighboring outlets of one HR unit are linked by Y branch pipe and connected to one indoor unit.

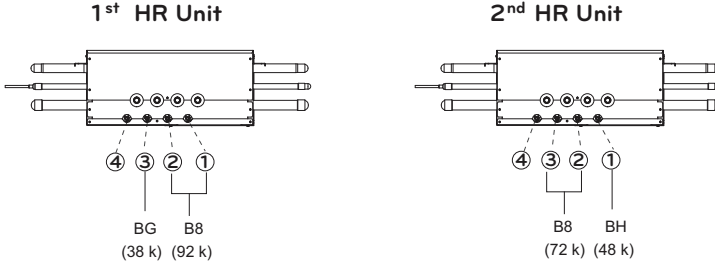

## NOTICE

1. A connection to un-neighboring pipes is forbidden. Do not link more than 2 outlets.

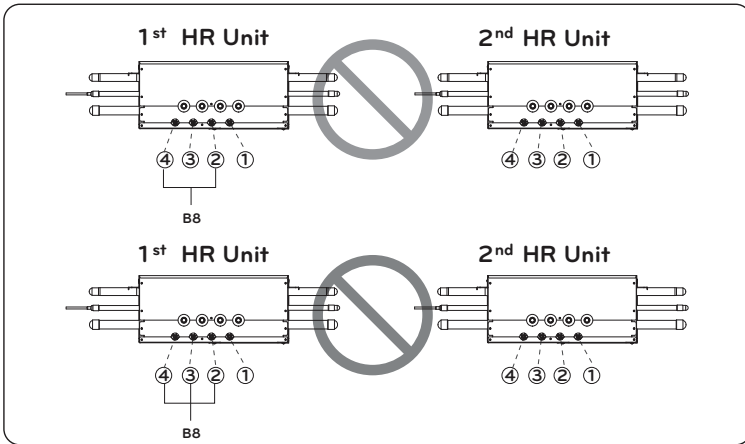

2. The B8 unit, which has the largest capacity, must be connected to the 1st and 2nd outlets of the 1st HR unit. Other B8 units can be connected to any two neighboring outlets within one HR unit.

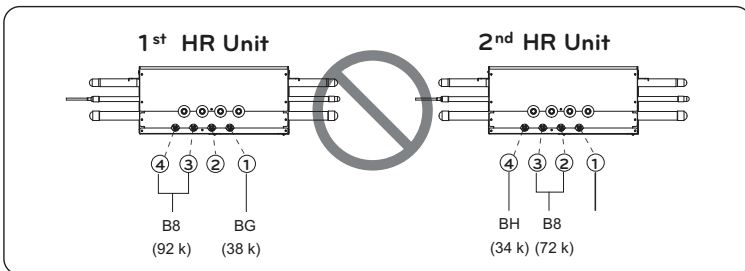

## Limiting concentration

Limiting concentration is the limit of Freon gas concentration where immediate measures can be taken without hurting human body when refrigerant leaks in the air. The limiting concentration shall be described in the unit of  $\text{kg/m}^3$  (Freon gas weight per unit air volume) for facilitating calculation.

Limiting concentration:  $0.44 \text{ kg/m}^3(\text{R410A})$

$$\text{Refrigerant concentration} \quad (\text{kg/m}^3) \quad = \quad \frac{\text{Total amount of replenished refrigerant in refrigerant facility (kg)}}{\text{Capacity of smallest room where indoor unit is installed (m}^3\text{)}}$$

