



# INSTALLATION MANUAL

# AIR CONDITIONER

Please read this installation manual completely before installing the product. Installation work must be performed in accordance with the national wiring standards by authorized personnel only.

Please retain this installation manual for future reference after reading it thoroughly.

**Hydro Kit** Floor Standing (Medium Temperature)  
Original instruction



MFL67086722  
Rev.01\_112025

[www.lg.com](http://www.lg.com)

Copyright © 2025 LG Electronics Inc. All Rights Reserved.

ENGLISH

ITALIANO

ESPAÑOL

FRANÇAIS

DEUTSCH

ΕΛΛΗΝΙΚΑ

ČEŠTINA

NEDERLANDS

POLSKI

LIMBA ROMÂNĂ

# TABLE OF CONTENTS

## 4 SAFETY INSTRUCTIONS

---

## 16 INSTALLATION PART

---

## 17 GENERAL INFORMATION

---

- 17 Model Information
- 17 Accessories

## 20 INSTALLATION

---

- 20 Transporting the Unit
- 20 Selection of the best location

## 21 SPECIAL REQUIREMENTS

---

- 21 Flow chart

## 25 INSTALLATION OF INDOOR UNIT

---

- 25 Conditions where Indoor Unit is Installed
- 27 Water Piping and Water Circuit Connection
- 30 Installation Scenes
- 38 Water Quality
- 38 Frost protection
- 39 Preparation for Piping
- 40 Electrical Wiring
- 41 Wiring Connection
- 43 Connecting Cables
- 44 Installation of Wired Remote Controller
- 46 Independent Power Module

## 48 ACCESSORIES INSTALLATION

---

- 48 Before Installation
- 48 Thermostat
- 51 DHW Tank
- 54 DHW Tank Kit
- 55 Solar Thermal Kit
- 56 Dry Contact
- 58 External Controller - Setting up programmable digital input operation
- 59 Remote Temperature Sensor
- 60 How to Install Remote Temperature Sensor
- 61 Solar pump
- 62 Wi-fi Modem
- 63 2Way Valve
- 64 3Way Valve(A)
- 65 Final check

---

## 66 SYSTEM SET-UP

---

66 DIP Switch Setting

---

## 71 SERVICE SETTING

---

71 How to enter service setting

71 Service setting

72 Service contact

73 Model information

74 RMC version Information

75 Open source license

---

## 76 INSTALLER SETTING

---

76 How to enter installer setting

77 Installer setting

---

## 93 COMMISSIONING

---

93 Check List before Starting Operation

94 Starting Operation

95 Starting Operation flow chart

95 Airborne Noise Emission





96 Decommissioning and Recycling

97 Troubleshooting

100 Model Designation

101 Open Source Software Notice Information

## SAFETY INSTRUCTIONS

|   |  |   |  |
|---|--|---|--|
|  | <p>Read the precautions in this manual carefully before operating the unit.</p>  |  | <p>This appliance is filled with flammable refrigerant (R32)</p>   |
|  | <p>This symbol indicates that the Operation Manual should be read carefully.</p> |  | <p>This symbol indicates that a service personnel should be handling this equipment with reference to the Installation Manual.</p> |

The following safety guidelines are intended to prevent unforeseen risks or damage from unsafe or incorrect operation of the appliance. The guidelines are separated into 'WARNING' and 'CAUTION' as described below.

 This symbol is displayed to indicate matters and operations that can cause risk. Read the part with this symbol carefully and follow the instructions in order to avoid risk.

### **WARNING**

This indicates that the failure to follow the instructions can cause serious injury or death.

### **CAUTION**

This indicates that the failure to follow the instructions can cause the minor injury or damage to the product.

## **WARNING**

### Installation

- Compliance with national gas regulations shall be observed.
- Do not use a defective or underrated circuit breaker. Use this appliance on a dedicated circuit.
  - There is risk of fire or electric shock.

- For electrical work, contact the dealer, seller, a qualified electrician, or an Authorized Service Center.
  - There is risk of fire or electric shock.
- Always ground the unit.
  - There is risk of fire or electric shock.
- Install the panel and the cover of control box securely.
  - There is risk of fire or electric shock.
- Always install a dedicated circuit and breaker.
  - Improper wiring or installation may cause fire or electric shock.
- Be cautious when unpacking and installing the product.
  - Sharp edges could cause injury. Be especially careful of the case edges and the fins on the condenser and evaporator.
- Use the correctly rated breaker or fuse.
  - There is risk of fire or electric.
- Do not modify or extend the power cable.
  - There is risk of fire or electric shock.
- Do not install, remove, or reinstall the unit by yourself (customer).
  - There is risk of fire, electric shock, explosion, or injury.
- For antifreeze, always contact the dealer or an authorized service center.
  - Almost the antifreeze is a toxic product.
- For installation, always contact the dealer or an Authorized Service Center.
  - There is risk of fire, electric shock, explosion, or injury.
- Do not install the unit on a defective installation stand.
  - It may cause injury, accident, or damage to the unit.
- Do not turn on the breaker or power under condition that front panel, cabinet, top cover, control box cover are removed or opened.
  - Otherwise, it may cause fire, electric shock, explosion or death.

- Be sure the installation area does not deteriorate with age.
  - If the base collapses, the unit could fall with it, causing property damage, unit failure, and personal injury.
- Do not install the unit outdoor.
  - It may cause damage to the unit.
- Use a vacuum pump or inert (nitrogen) gas when doing leakage test or purging air. Do not compress air or oxygen and do not use flammable gases.
  - There is the risk of death, injury, fire or explosion.
- The appliance shall be stored in a well-ventilated area where the room size corresponds to the room area as specified for operation. (for R32)
- Ducts connected to an appliance shall not contain an ignition source. (for R32)
- The appliance shall be stored in a room without continuously operating ignition sources (for example: open flames, an operating gas appliance or an operating electric heater.)
- Means for disconnection must be incorporated in the fixed wiring in accordance with the wiring rules.
- This equipment shall be provided with a supply conductor complying with the national regulation.
- Have all electric work done by a licensed electrician according to "Electric Facility Engineering Standard" and "Interior Wire Regulations" and the instructions given in this manual and always use a special circuit.
  - If the power source capacity is inadequate or electric work is performed improperly, electric shock or fire may result.
- Always install a dedicated circuit and breaker.
  - Improper wiring or installation may cause fire or electric shock.
- Keep any required ventilation openings clear of obstruction.
- Mechanical connections shall be accessible for maintenance purposes.

- To prevent the mixing of different types of refrigerants, be sure to check the type of refrigerant used in the outdoor unit.
- When mechanical connectors are reused indoors, sealing parts shall be renewed. (for R32)
- When flared joints are reused indoors, the flare part shall be re-fabricated. (for R32)

## Operation

- Do not let the air conditioner run for a long time when the humidity is very high and a door or a window is left open.
  - Moisture may condense and wet or damage furniture.
- Take care to ensure that power cable could not be pulled out or damaged during operation.
  - There is risk of fire or electric shock.
- Do not place anything on the power cable.
  - There is risk of fire or electric shock.
- Do not plug or unplug the power supply plug during operation.
  - There is risk of fire or electric shock.
- Do not touch (operate) the unit with wet hands.
  - There is risk of fire or electric shock.
- Do not place a heater or other appliances near the power cable.
  - There is risk of fire or electric shock.
- Do not allow water to run into electric parts.
  - There is risk of fire, failure of the unit, or electric shock.
- Do not store or use flammable gas or combustibles near the unit.
  - There is risk of fire or failure of unit.
- Do not use the product in a tightly closed space for a long time.
  - Oxygen deficiency could occur.

- When flammable gas leaks, turn off the gas and open a window for ventilation before turning the unit on.
  - There is risk of explosion or fire.
- If strange sounds, or smell or smoke comes from unit, turn the breaker off or disconnect the power supply cable.
  - There is risk of electric shock or fire.
- Stop operation and close the window in storm or hurricane. If possible, remove the unit from the window before the hurricane arrives.
  - There is risk of property damage, failure of unit, or electric shock.
- Do not open the front cover of the unit while operation. (Do not touch the electrostatic filter, if the unit is so equipped.)
  - There is risk of physical injury, electric shock, or unit failure.
- When the unit is soaked (flooded or submerged), contact an Authorized Service Center.
  - There is risk of fire or electric shock.
- Be cautious that water could not enter the product.
  - There is risk of fire, electric shock, or product damage.
- Ventilate the unit from time to time when operating it together with a stove, etc.
  - There is risk of fire or electric shock.
- Turn the main power off when cleaning or maintaining the unit.
  - There is risk of electric shock.
- Take care to ensure that nobody could step on or fall onto the unit.
  - This could result in personal injury and unit damage.
- For installation, always contact the dealer or an Authorized Service Center.
  - There is risk of fire, electric shock, explosion, or injury.
- If the unit is not used for long time, we strongly recommend not to switch off the power supply to the unit.
  - There is risk of water freezing.

- Periodic (more than once/year) cleaning of the dust or salt particles stuck on the heat exchanger by using water.
- Do not use means to accelerate the defrosting process or to clean, other than those recommended by the manufacturer.
- Do not pierce or burn refrigerant cycle part.
- Be aware that refrigerants may not contain an odour.

## CAUTION

### Installation

- Always check for gas (refrigerant) leakage after installation or repair of unit.
  - Low refrigerant levels may cause failure of unit.
- Keep level even when installing the unit.
  - To avoid vibration or water leakage.
- Use two or more people to lift and transport the unit.
  - Avoid personal injury.
- Any person who is involved with working on or breaking into a refrigerant circuit should hold a current valid certificate from an industry accredited assessment authority, which authorises their competence to handle refrigerants safely in accordance with an industry recognised assessment specification. (for R32)
- The appliance shall be stored so as to prevent mechanical damage from occurring.
- If anyone other than a licensed Professional installs, repairs, or alters LG Electronics Air Conditioning Products, the warranty is voided.
  - All costs associated with repair are then the full responsibility of the owner.
- Do not install the product where it will be exposed to sea wind (salt spray) directly.
  - It may cause corrosion on the product. Corrosion, particularly on the condenser and evaporator fins, could cause product malfunction or inefficient operation.

- Refrigerant tubing shall be protected or enclosed to avoid damage.
- Flexible refrigerant connectors (such as connecting lines between the indoor and outdoor unit) that may be displaced during normal operations shall be protected against mechanical damage.
- The installation of pipe-work shall be kept to a minimum.
- Pipe-work shall be protected from physical damage.
- A brazed, welded, or mechanical connection shall be made before opening the valves to permit refrigerant to flow between the refrigerating system parts.
- Dismantling the unit, treatment of the refrigerant oil and eventual parts should be done in accordance with local and national standards.
- Do not install the unit in potentially explosive atmospheres.

### Operation

- Do not lay on the cooled floor for long time when the unit is in cooling operation.
  - This could harm to your health.
- Do not use the unit for special purposes, such as preserving foods, works of art, etc.
  - There is risk of damage or loss of property.
- Use a soft cloth to clean. Do not use harsh detergents, solvents, etc.
  - There is risk of fire, electric shock, or damage to the plastic parts of the unit.
- Do not step on or put anything on the unit.
  - There is risk of personal injury and failure of unit.
- Use a firm stool or ladder when cleaning or maintaining the unit.
  - Be careful and avoid personal injury.

- Servicing shall only be performed as recommended by the equipment manufacturer. Maintenance and repair requiring the assistance of other skilled personnel shall be carried out under the supervision of the person competent in the use of flammable refrigerants. (for R32)
- Do not unplug the power supply plug of **Hydro Kit** when stopping **Hydro Kit** operation. Always turn **Hydro Kit** off, using the wired remote controller.
  - A plate heat exchanger burst may happen because of disconnection of communication between **Hydro Kit** and the outdoor unit.
- A discharge pipe connected to the pressure-relief device is to be installed in a continuously downward direction and in a frost-free environment.

### Ventilated area

Ensure that the area is in the open or that it is adequately ventilated before breaking into the system or conducting any hot work. A degree of ventilation shall continue during the period that the work is carried out. The ventilation should safely disperse any released refrigerant and preferably expel it externally into the atmosphere.

### Cabling

Cabling will not be subject to wear, corrosion, excessive pressure, vibration, sharp edges or any other adverse environmental effects. The check shall also take into account the effects of ageing or continual vibration from sources such as compressors or fans.

### Detection of flammable refrigerants

Under no circumstances shall potential sources of ignition be used in the searching for or detection of refrigerant leaks. A halide torch (or any other detector using a naked flame) shall not be used.

## Leak detection methods

The following leak detection methods are deemed acceptable for systems containing flammable refrigerants.

Electronic leak detectors shall be used to detect flammable refrigerants, but the sensitivity may not be adequate, or may need re-calibration. (Detection equipment shall be calibrated in a refrigerant-free area.)

Ensure that the detector is not a potential source of ignition and is suitable for the refrigerant used.

Leak detection equipment shall be set at a percentage of the LFL of the refrigerant and shall be calibrated to the refrigerant employed and the appropriate percentage of gas (25 % maximum) is confirmed.

Leak detection fluids are also suitable for use with most refrigerants but the use of detergents containing chlorine shall be avoided as the chlorine may react with the refrigerant and corrode the copper pipe-work.

### NOTE

Examples of leak detection fluids are

- bubble method
- fluorescent method agents

If a leak is suspected, all naked flames shall be removed/extinguished.

If a leakage of refrigerant is found which requires brazing, all of the refrigerant shall be recovered from the system, or isolated (by means of shut off valves) in a part of the system remote from the leak. Removal of refrigerant shall be according to removal and evacuation procedure.

## Removal and evacuation

When breaking into the refrigerant circuit to make repairs - or for any other purpose - conventional procedures shall be used. However, for flammable refrigerants it is important that best practice be followed, since flammability is a consideration.

The following procedure shall be adhered to:

- a) safely remove refrigerant following local and national regulations;
- b) purge the circuit with inert gas;
- c) evacuate (optional for A2L);
- d) purge with inert gas (optional for A2L);
- e) open the circuit by cutting or brazing.

The refrigerant charge shall be recovered into the correct recovery cylinders if venting is not allowed by local and national codes. For appliances containing flammable refrigerants, the system shall be purged with oxygen-free nitrogen to render the appliance safe for flammable refrigerants. This process might need to be repeated several times. Compressed air or oxygen shall not be used for purging refrigerant systems.

For appliances containing flammable refrigerants, refrigerants purging shall be achieved by breaking the vacuum in the system with oxygen-free nitrogen and continuing to fill until the working pressure is achieved, then venting to atmosphere, and finally pulling down to a vacuum (optional for A2L).

This process shall be repeated until no refrigerant is within the system (optional for A2L).

When the final oxygen-free nitrogen charge is used, the system shall be vented down to atmospheric pressure to enable work to take place.

Ensure that the outlet for the vacuum pump is not close to any potential ignition sources and that ventilation is available.

## Charging procedures

In addition to conventional charging procedures, the following requirements shall be followed.

- Ensure that contamination of different refrigerants does not occur when using charging equipment. Hoses or lines shall be as short as possible to minimise the amount of refrigerant contained in them.
- Cylinders shall be kept in an appropriate position according to the instruction.
- Ensure that the refrigerating system is earthed prior to charging the system with refrigerant.
- Label the system when charging is complete (if not already).
- Extreme care shall be taken not to overfill the refrigerating system.

Prior to recharging the system, it shall be pressure tested with the appropriate purging gas.

The system shall be leak-tested on completion of charging but prior to commissioning. A follow up leak test shall be carried out prior to leaving the site.

## Recovery

When removing refrigerant from a system, either for servicing or decommissioning, it is recommended good practice that all refrigerants are removed safely.

When transferring refrigerant into cylinders, ensure that only appropriate refrigerant recovery cylinders are employed.

Ensure that the correct number of cylinders for holding the total system charge are available. All cylinders to be used are designated for the recovered refrigerant and labelled for that refrigerant (i.e. special cylinders for the recovery of refrigerant).

Cylinders shall be complete with pressure relief valve and associated shut-off valves in good working order.

Empty recovery cylinders are evacuated and, if possible, cooled before recovery occurs. The recovery equipment shall be in good working order with a set of instructions concerning the equipment that is at hand and shall be suitable for the recovery of flammable refrigerants. In addition, a set of calibrated weighing scales shall be available and in good working order.

Hoses shall be complete with leak-free disconnect couplings and in good condition. Before using the recovery machine, check that it is in satisfactory working order, has been properly maintained and that any associated electrical components are sealed to prevent ignition in the event of a refrigerant release.

Consult manufacturer if in doubt. The recovered refrigerant shall be returned to the refrigerant supplier in the correct recovery cylinder, and the relevant Waste Transfer Note arranged.

Do not mix refrigerants in recovery units and especially not in cylinders. If compressors or compressor oils are to be removed, ensure that they have been evacuated to an acceptable level to make certain that flammable refrigerant does not remain within the lubricant.

The evacuation process shall be carried out prior to returning the compressor to the suppliers. Only electric heating to the compressor body shall be employed to accelerate this process. When oil is drained from a system, it shall be carried out safely.

Connect the water for filling or refilling the heating system as specified by EN 1717/EN 61770 to avoid contamination of drinking water by return flow.





Servicing shall only be performed as recommended by the equipment manufacturer.

# INSTALLATION PART

Thank you for choosing LG Electronics **Hydro Kit**.

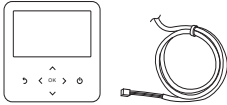
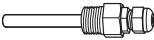
Before starting installation, please make it sure that all parts are found inside the unit box.

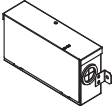
## Indoor Unit Box

| Item  | Image   | Quantity |
|---|---|----------|
| Remote Controller / Cable                         |    | 1        |
| Sensor Holder                                     |    | 1        |
| Water Tank Temperature Sensor                     |    | 1        |
| Independent Power Module (For Medium Temperature) |    | 1        |
| Owner's & Installation manual                     |   | 1        |
| CN_EXT Cable                                      |  | 1        |

# GENERAL INFORMATION

With advanced inverter technology, **Hydro Kit** is suitable for applications like under floor heating, and hot water generation. By Interfacing to various accessories user can customize the range of the application.

## Model Information

### Model name and related information

| Type         |         | Hydro Kit |                |         |         |
|--------------|---------|-----------|----------------|---------|---------|
| HP           |         | 4         | 10             | 16      |         |
| Power Supply |         | Ø, V, Hz  | 1, 220-240, 50 |         |         |
| Capacity     | Cooling | kW        | 12.3           | 28.0    | 46.4    |
|              |         | kcal/h    | 10 580         | 24 100  | 39 900  |
|              |         | Btu/h     | 42 000         | 95 900  | 158 300 |
|              | Heating | kW        | 13.8           | 31.5    | 52.0    |
|              |         | kcal/h    | 11 870         | 27 100  | 44 700  |
|              |         | Btu/h     | 47 000         | 107 500 | 177 400 |

\*1 : Tested under Eurovent Heating condition  
(water temperature 30 °C → 35 °C at outdoor ambient temperature 7 °C / 6 °C)

\*2 : Tested under Eurovent Cooling condition  
(water temperature 23 °C → 18 °C at outdoor ambient temperature 35 °C / 24 °C)

- Max Allowable pressure High side: 4.2 MPa / Low Side : 2.4 MPa
- Max Allowable water temperature High side: 50 °C / Low side : 10 °C
- Max Allowable water pressure: 0.98 MPa (0.3~10 kgf/cm<sup>2</sup>)

## Accessories

To extend the functionality of **Hydro Kit**, there are various external auxiliary apparatus called as "accessories".

They are classified by "accessories" and "3rd party accessories" according to the manufacturer. Accessories are presented LG Electronics, and 3rd party accessories are presented by related manufacturers.

## Accessories supported by LG Electronics

| Item                         | Purpose  | Model   |
|------------------------------|--|---|
| DHW Tank Kit                 | To operate with DHW tank   | PHLTB : 1Ø  |
| Remote Air Sensor            | To control by air temperature  | PQRSTA0   |
| Dry Contact                  | 1 input port, AC 220 - 240V  | PDRYCB000<br>PDRYCB100  |
|                              | 8 input port, For 3rd Party Thermostat                               | PDRYCB300   |
|                              | 8 input port, For 3rd Party Thermostat (AnalogInput)                 | PDRYCB320   |
| Solar Thermal Kit            | To operate with solar heating system                                 | PHLLA(Limit temperature : 96 °C)  |
| DHW Tank                     | To generate and store hot water                                      | OSHW-200F : 200 L, Single Heating Coil<br>OSHW-300F : 300 L, Single Heating Coil<br>OSHW-500F : 500 L, Single Heating Coil<br>OSHW-300FD : 300 L, Double Heating Coil |
| Thermistor for DHW Tank      | To control hot water temperature of DHW tank                         | PHRSTA0   |
| Central Controller           | Multiple installed products into one central control                 |   |
| Wi-Fi Modem                  | To enable remote system operation from smartphone                    | PWFMD200  |
| Extension wire               | To connect remote controller with Indoor PCB for communication       | PZCWRC1   |
| Remote Temperature sensor    | -  | PQRSTA0   |
| Group Control wire           | Cable Assembly for group control (Y-typecable : 0.25m, cable : 9.6m) | PZCWRG3   |
| Refrigerant Leakage Detector | R410A  | PRLDNV50  |
|                              | R32  | PLDRNV1S  |
| 2nd Circuit Thermistor       | -  | PRSTAT5K10  |

## Accessories supported by 3rd party Companies

| Item                             | Purpose  | Specification  |
|----------------------------------|--|--|
| Solar Heating System             | To generate auxiliary heating energy for water tank  | Solar collector  |
| Thermostat                       | To control by air temperature  | Heating-Only type (230 V AC)<br>Cooling/Heating type<br>(230 V AC with Mode selection switch)                    |
| Mix Kit                          | To use mixing circuit  | <ul style="list-style-type: none"> <li>• Mixing valve</li> <li>• Mix pump</li> <li>• Mix Valve Sensor</li> </ul> |
| 3 <sup>rd</sup> Party Controller | To connect external controller using modbus protocol   |  |
| 3way valve and actuator          | (A) : To control water flow for hot water heating or floor heating /<br>To control water flow when installing 3rd party boiler | 3 wire, SPDT<br>(Single Pole Double Throw) type,<br>230 V AC   |
| 2way valve and actuator          | To control water flow for Fan Coil Unit  | 2 wire, NO(Normal Open) or<br>NC(Normal Closed) type, 230 V AC   |
| 3rd Party ESS                    | To control the operation mode according to the energy storage state  |  |

# INSTALLATION

## Transporting the Unit

### CAUTION

Be very careful while carrying the unit.

- Do not have only one person carry the unit if it is more than 20 kg (44.1 lbs).
- PP bands are used to pack some products. Do not use them as a mean for transportation because they are dangerous.
- Tear plastic packaging bag and scrap it so that children cannot play with it. Otherwise plastic packaging bag may suffocate children to death.
- When carrying the unit, be sure to support it at 6-points. Carrying and lifting the unit with 4-point support may make it unstable, resulting in a fall.

## Selection of the best location

Select space for installing the unit, which will meet the following conditions:

The place where the unit shall be installed inside.

The place shall easily bear a load exceeding four times of the unit weight.

The place where the unit shall be leveled.

The place shall allow easy water drainage.

The place where the unit shall be connected to the outdoor unit.

The place where the unit is not affected by an electrical noise.

The place where there should not be any heat source or steam near the unit.

# SPECIAL REQUIREMENTS

## Flow chart

### For Installation

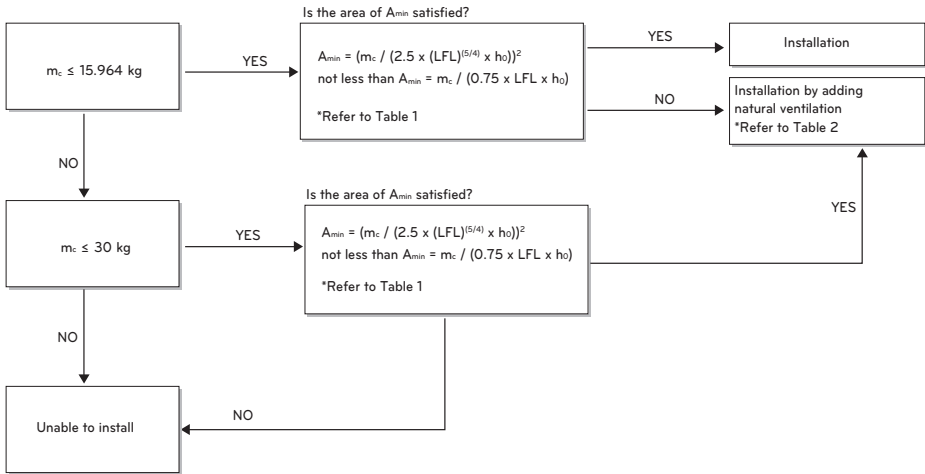

- $A_{min}$  = Minimum installation required area
- $m_c$  = Total amount of refrigerant in the system (kg)
- LFL(Lower Flammability Limit)(kg/m<sup>3</sup>) = 0.307 kg/m<sup>3</sup>
- $h_o$ : The Vertical Distance from the floor to the point of Release (m)

**Table 1: Minimum installation required area**

| Total amount of refrigerant in the system (kg) | Minimum installation required area (m <sup>2</sup> ) |  | Total amount of refrigerant in the system (kg) | Minimum installation required area (m <sup>2</sup> ) |  |
|--|--|--|--|--|--|
|  | Floor standing (h <sub>0</sub> : 0.6 m)              |  |  | Floor standing (h <sub>0</sub> : 0.6 m)              |  |
| 1.50   | 19.15  |  | 10.40  | 920.53   |  |
| 1.60   | 21.79  |  | 10.60  | 956.28   |  |
| 1.80   | 27.58  |  | 10.80  | 992.70   |  |
| 2.00   | 34.04  |  | 11.00  | 1029.81  |  |
| 2.20   | 41.19  |  | 11.20  | 1067.60  |  |
| 2.40   | 49.02  |  | 11.40  | 1106.07  |  |
| 2.60   | 57.53  |  | 11.60  | 1145.22  |  |
| 2.80   | 66.72  |  | 11.80  | 1185.05  |  |
| 3.00   | 76.60  |  | 12.00  | 1225.56  |  |
| 3.20   | 87.15  |  | 12.20  | 1266.75  |  |
| 3.40   | 98.39  |  | 12.40  | 1308.62  |  |
| 3.60   | 110.30   |  | 12.60  | 1351.18  |  |
| 3.80   | 122.90   |  | 12.80  | 1394.41  |  |
| 4.00   | 136.17   |  | 13.00  | 1438.33  |  |
| 4.20   | 150.13   |  | 13.20  | 1482.93  |  |
| 4.40   | 164.77   |  | 13.40  | 1528.20  |  |
| 4.60   | 180.09   |  | 13.60  | 1574.16  |  |
| 4.80   | 196.09   |  | 13.80  | 1620.80  |  |
| 5.00   | 212.77   |  | 14.00  | 1668.12  |  |
| 5.20   | 230.13   |  | 14.20  | 1716.12  |  |
| 5.40   | 248.18   |  | 14.40  | 1764.80  |  |
| 5.60   | 266.90   |  | 14.60  | 1814.17  |  |
| 5.80   | 286.30   |  | 14.80  | 1864.21  |  |
| 6.00   | 306.39   |  | 15.00  | 1914.94  |  |
| 6.20   | 327.16   |  | 15.20  | 1966.34  |  |
| 6.40   | 348.60   |  | 15.40  | 2018.43  |  |
| 6.60   | 370.73   |  | 15.60  | 2071.19  |  |
| 6.80   | 393.54   |  | 15.80  | 2124.64  |  |
| 7.00   | 417.03   |  | 15.964 *                                       | 2168.98  |  |
| 7.20   | 441.20   |  | 16.00  | 2178.77  |  |
| 7.40   | 466.05   |  | 16.20  | 2233.58  |  |
| 7.60   | 491.59   |  | 16.40  | 2289.07  |  |
| 7.80   | 517.80   |  | 16.60  | 2345.24  |  |
| 8.00   | 544.69   |  | 16.80  | 2402.09  |  |
| 8.20   | 572.27   |  | 17.00  | 2459.63  |  |
| 8.40   | 600.52   |  | 17.20  | 2517.84  |  |
| 8.60   | 629.46   |  | 17.40  | 2576.74  |  |
| 8.80   | 659.08   |  | 17.60  | 2636.31  |  |
| 9.00   | 689.38   |  | 17.80  | 2696.57  |  |
| 9.20   | 720.36   |  | 18.00  | 2757.51  |  |
| 9.40   | 752.02   |  | 18.20  | 2819.12  |  |
| 9.60   | 784.36   |  | 18.40  | 2881.42  |  |
| 9.80   | 817.38   |  | 18.60  | 2944.40  |  |
| 10.00  | 851.08   |  | 18.80  | 3008.07  |  |
| 10.20  | 885.47   |  | 19.00  | 3072.41  |  |

\* If  $m_c > 15.964$ , must add natural ventilation

| Total amount of refrigerant in the system (kg) | Minimum installation required area (m <sup>2</sup> ) |
|--|--|
|  | Floor standing (h <sub>0</sub> : 0.6 m)              |
| 19.20  | 3137.43  |
| 19.40  | 3203.13  |
| 19.60  | 3269.52  |
| 19.80  | 3336.58  |
| 20.00  | 3404.33  |
| 20.20  | 3472.76  |
| 20.40  | 3541.86  |
| 20.60  | 3611.65  |
| 20.80  | 3682.12  |
| 21.00  | 3753.27  |
| 21.20  | 3825.10  |
| 21.40  | 3897.62  |
| 21.60  | 3970.81  |
| 21.80  | 4044.68  |
| 22.00  | 4119.24  |
| 22.20  | 4194.47  |
| 22.40  | 4270.39  |
| 22.60  | 4346.99  |
| 22.80  | 4424.27  |
| 23.00  | 4502.23  |
| 23.20  | 4580.87  |
| 23.40  | 4660.19  |
| 23.60  | 4740.19  |
| 23.80  | 4820.87  |
| 24.00  | 4902.23  |
| 24.20  | 4984.28  |
| 24.40  | 5067.00  |
| 24.60  | 5150.41  |

| Total amount of refrigerant in the system (kg) | Minimum installation required area (m <sup>2</sup> ) |
|--|--|
|  | Floor standing (h <sub>0</sub> : 0.6 m)              |
| 24.80  | 5234.50  |
| 25.00  | 5319.26  |
| 25.20  | 5404.71  |
| 25.40  | 5490.84  |
| 25.60  | 5577.65  |
| 25.80  | 5665.14  |
| 26.00  | 5753.32  |
| 26.20  | 5842.17  |
| 26.40  | 5931.70  |
| 26.60  | 6021.92  |
| 26.80  | 6112.81  |
| 27.00  | 6204.39  |
| 27.20  | 6296.65  |
| 27.40  | 6389.59  |
| 27.60  | 6483.20  |
| 27.80  | 6577.50  |
| 28.00  | 6672.48  |
| 28.20  | 6768.15  |
| 28.40  | 6864.49  |
| 28.60  | 6961.51  |
| 28.80  | 7059.22  |
| 29.00  | 7157.60  |
| 29.20  | 7256.67  |
| 29.40  | 7356.41  |
| 29.60  | 7456.84  |
| 29.80  | 7557.95  |
| 30.00  | 7659.74  |

\* If m<sub>c</sub> > 15.964, must add natural ventilation

Minimum installation required area (m<sup>2</sup>)

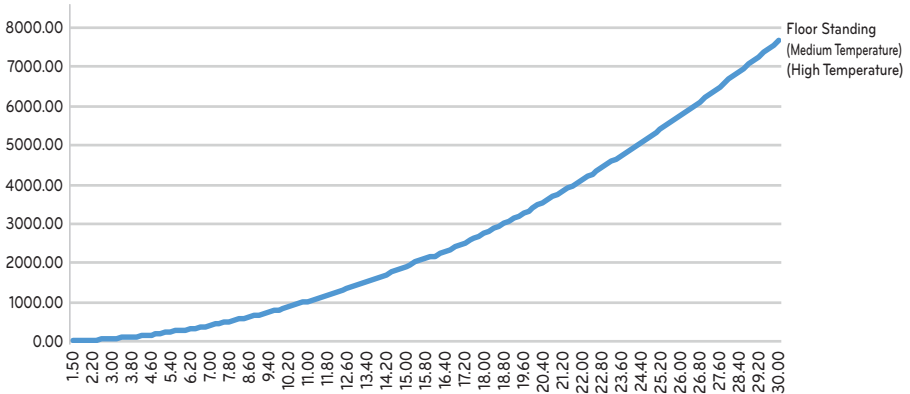
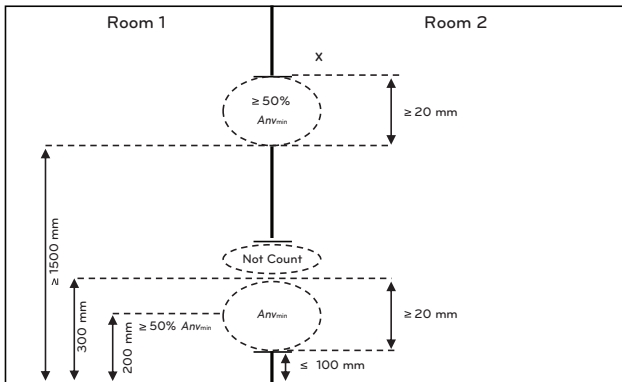

**Table 2: Minimum installation required area****For the lower opening:**

- It is not an opening to the outside
- The opening cannot be closed
- The opening must be  $\geq Anv_{min}$
- The area of any openings above 300 mm from the floor does not count when determining  $Anv_{min}$
- At least 50% of  $Anv_{min}$  is less than 200 mm above the floor
- The bottom of the lower opening is  $\leq 100$  mm from the floor
- The height of the opening is  $\geq 20$  mm

**For the upper opening:**

- It is not an opening to the outside
- The opening cannot be closed
- The opening must be  $\geq 50\%$  of  $Anv_{min}$
- The bottom of the upper opening must be  $\geq 1\,500$  mm above the floor
- The height of the opening is  $\geq 20$  mm

**Minimum opening area ( $Anv$ )**

$$Anv_{min} = \frac{m_c - m_{max}}{LFL \times 104} \times \sqrt{\frac{A}{g \times m_{max}} \frac{M}{M - 29}}$$

- $Anv$  Is the minimum opening for natural ventilation in  $m^2$ .
- $m_c$  Is the actual refrigerant charge of refrigerant in the system in kg;
- $m_{max}$  Is the allowable maximum refrigerant charge in the system in kg, calculated according to Equation GG.8 or  $m^2$ , whichever is lower,
- LFL Is the lower flammability limit in  $kg/m^3$ ;
- A Is the room area in  $m^2$ ;
- M Is the molar mass of the refrigerant in  $kg/kmol$ ;
- g Is the gravity acceleration of  $9,81 m/s^2$ ;
- 29 Is the average molar mass of air in  $kg/kmol$ .

# INSTALLATION OF INDOOR UNIT

The indoor unit of **Hydro Kit** is installed inside where terminal of under floor water pipe cycle and refrigerant pipe from the outdoor unit are accessible at the same time.

In this chapter conditions for installation place is described. In addition, considerations when installing accessories or 3rd party accessories are described, too.

## Conditions where Indoor Unit is Installed

Specific conditions are required for installation place such as service space, wall mounting, water pipe length and height, total volume of water, adjusting expansion vessel, and water quality.

### General Considerations

Followings are should be considered before the installation of the indoor unit.

- The installation place should be free from outdoor weather conditions such as rain, snow, wind, frost, etc.
- Choose the place where is water-resistant or good drainage.
- Service space should be secured.
- No flammable materials around the indoor unit.
- Mice can not be appeared to prevent entering the indoor unit or attacking wires.
- Do not place anything in front of the indoor unit to ensure air circulation around the indoor unit.
- Do not locate anything under the indoor unit to be free from unexpected water out.
- In case of water pressure increasing to 3 bar, water drainage should be treated when water is drained by safety valve.

### Service Space

- Ensure that the spaces indicated by arrows around bottom, side, and top side.
- Ensure that the minimum service space from the product to combustible surfaces.
- Wider spaces are preferred for easy maintenance and piping.
- If minimum service space is not secured, air circulation can be troubled and internal parts of the indoor unit can be damaged by overheating.

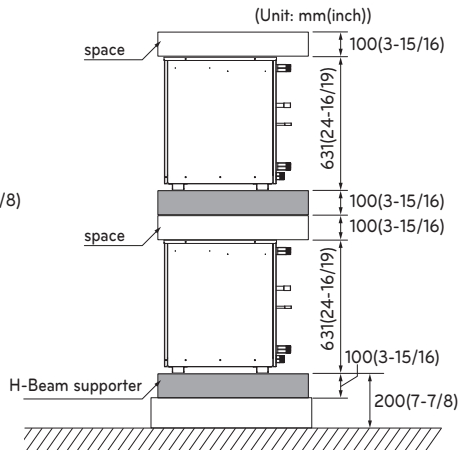
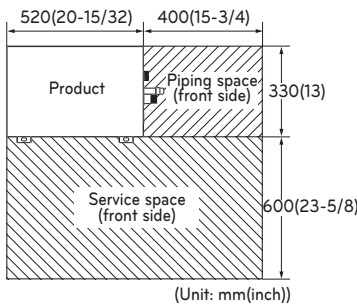

## Foundation for Installation

- Fix the unit tightly with bolts as shown below so that the unit will not fall down due to earthquake.
- Noise and vibration may occur from the floor or wall since vibration is transferred through the installation part depending on installation status. Thus, use anti-vibration materials (cushion pad) fully (The base pad shall be more than 200 mm (7-7/8 inch)).

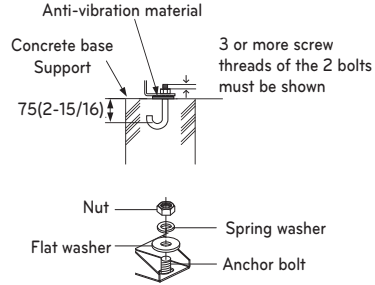
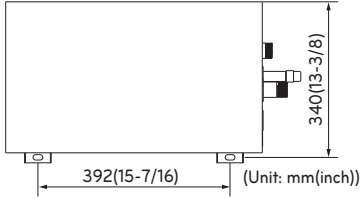

## CAUTION

- When mechanical connectors are reused indoors, sealing parts shall be renewed. (for R32)
- When flared joints are reused indoors, the flare part shall be re-fabricated. (for R32)

## Drain pipe connection

- **Hydro Kit** does not use the drain pump.
- Do not install in upward direction.
- Install the drain pipe in downward direction (1/50-1/100).
- **Hydro Kit** drain connection pipe is PT 1.

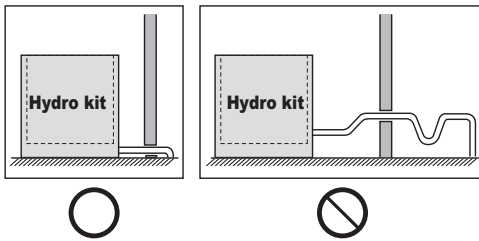

## Water Piping and Water Circuit Connection

### General Considerations

Followings should be considered before beginning water circuit connection.

- Service space should be secured.
- Water pipes and connections should be cleaned using water.
- Space for installing external water pump should be provided.
- Never connect electric power while proceeding water charging.

### Water Piping and Water Circuit Connection

While installing water pipes, followings should be considered :

- While inserting or putting water pipes, close the end of the pipe with pipe cap to avoid dust entering.
- When cutting or welding the pipe, always be careful that inner section of the pipe should not be defective. For example, no weldments or no burrs are found inside the pipe.
- Pipe fittings (e.g. L-shape elbow, T-shape tee, diameter reducer, etc) should be tightened strongly to be free from water leakage.
- Connected sections should be leakage-proof treatment by applying teflon tape, rubber bushing, sealant solution, etc.
- Appropriate tools and tooling methods should be applied to prevent mechanical breakage of the connections.
- Operation time of flow valve(e.g. 3way valve or 2way valve) should be less than 90 seconds.
- Pipe is insulated to prevent heat loss to external environment.

### Strainer

- Use the 30 mesh strainer. (Exclude scale diameter of 0.8 mm or less and other net)
- Check the strainer direction and assemble on the inlet hole (Refer to picture)
- Wrap the Teflon tape on the screw thread of the water pipe for more than 15 times for assembly.
- Install the service port facing downward. (Within left/right 45 degrees)
- Check if there is any leakage on the connecting part.
- Clean the strainer periodically. (Once a year or more frequent)

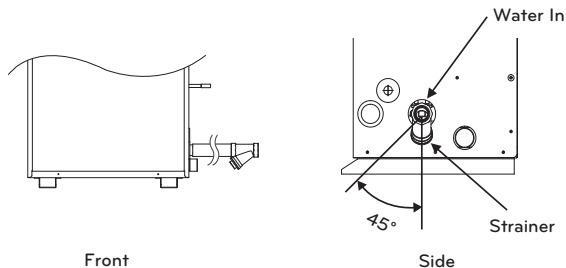

## Water cycle minimum requirements

1. For selecting the components of the hydraulic system, be sure they are above the design water pressure.
2. For the water pipe, diffusely tight water pipes are recommended instead of steel pipes.
3. For the drain pipe size, use the same diameter as the product connected or larger. Always install a natural drainage so that the drained water does not flows back
4. Install insulated material across the total hydraulic piping to prevent condensation and to prevent low cooling or heating capacity during heat transfer losses. If the temperature is higher than 30 °C and the humidity is higher than 80 % the insulation material must be minimum 20 mm thick to prevent condensation.
5. Install the shut-off valve (1) to block the water by closing the valve when replacing the component or cleaning.
6. Install an expansion tank (2) based on the water volume of the hydraulic system.
7. Install the drain valve (3) that can be used for draining the water inside when replacing the component or providing service.
8. Install a magnetic dirt separator (4) at the inlet water pipe If the air separator is not installed there can be formed air bubbles inside the hydraulic system. Flow error will be showed first on remote controller, however finally a plate heat exchanger may burst during combined circumstances.
9. Install a circulation pump (5) which meets the water flow specifications mentioned inside product data book.
10. Install the strainer (6) at the inlet water pipe connection to protect the PHE. Do not charge water into the water pipe directly during **Hydro Kit** operation. If the strainer is not installed, component malfunction of **Hydro Kit** may occur.
  - For the strainer, use one with 30 mesh or above with measurement diameter of 0.8 mm or less.
  - Always install the strainer on the horizontal pipe.
11. Install a balancing valve (with flow meter) (8)
12. Install an automatic air separator in the outlet water pipe (9)
13. Install pressure safety relief valve (10) in vertical upright position that meets the design water pressure to prevent unit or water pipe damage during pressure increase inside the water pipe system.
14. Install a pressure meter (11) in the outlet water pipe.
15. Install in case of cascade hydraulic systems or bivalent systems a flow-check valve (12) at each outlet water pipe.
16. Install a buffer tank (13) of at least 10L/kW heating capacity in order to have a correct defrost cycle, if there is no knowledge about the type and dimensions of the heating system. If there is no buffer tank installed, the product can be damaged during normal operation or defrost operation.
17. After product operation for 2 weeks in case of new installation, clean the water filter. In the beginning of operation small particular dirt from installing process can block the filter which can lead to damage of the product.

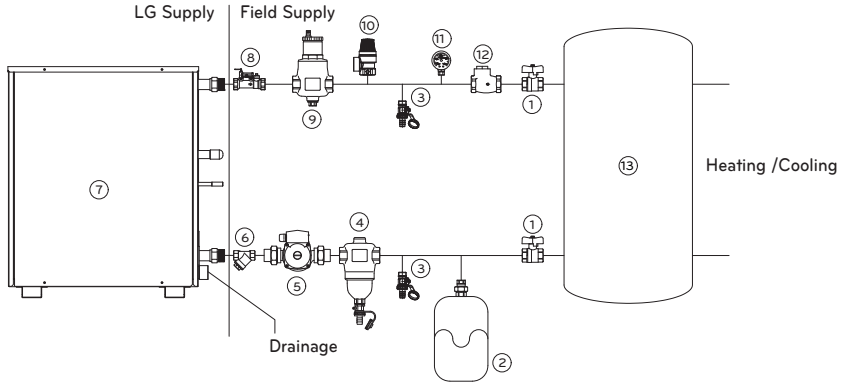

|   |                                   |    |   |
|---|-----------------------------------|----|---|
| 1 | Shut-Off valve                    | 8  | Balancing valve with flow meter                       |
| 2 | Expansion tank                    | 9  | Automatic air separator                               |
| 3 | Service port(Drain valve)         | 10 | Pressure safety relief valve                          |
| 4 | Magnetic filter(Recommended)      | 11 | Pressure meter  |
| 5 | Water Pump                        | 12 | Check valve   |
| 6 | Strainer                          | 13 | Buffer tank / DHW <sup>1)</sup> (Sanitary Water) Tank |
| 7 | Flow switch (included in product) |    |   |

### NOTE

Install the closed loop type water pipe system.

Balancing valve with flow meter is recommended to ensure 100 % of the nominal flow.

<sup>1)</sup> DHW : Domestic Hot Water.

## Installation Scenes

Installation scenes are presented for example.

Installer should optimize the installation scene according to the installation conditions and local/national regulation.

i.e. Shut-off valves position for spare water pump and water pump service, Flexible joint installation to prevent noise and vibration.

### 1) Space Heating/Cooling<sup>1)</sup> Installation

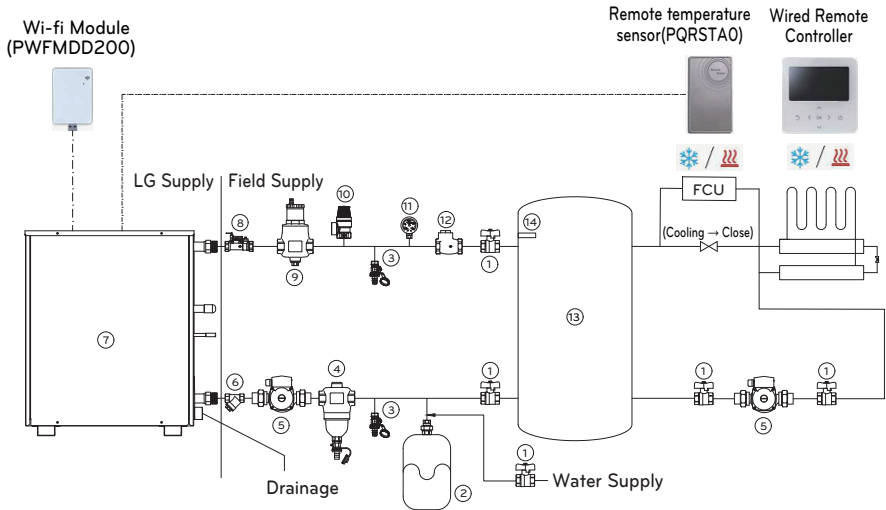

|   |   |    |                                      |
|---|---|----|--------------------------------------|
| 1 | Shut-Off valve  | 8  | Balancing valve with flow meter      |
| 2 | Expansion tank  | 9  | Automatic air separator              |
| 3 | Service port(Drain valve)                                   | 10 | Pressure safety relief valve         |
| 4 | Magnetic filter (Mandatory with Corrosive material of pipe) | 11 | Pressure meter                       |
| 5 | Water Pump  | 12 | Check valve                          |
| 6 | Strainer  | 13 | Buffer Tank                          |
| 7 | Flow switch (included in product)                           | 14 | Water Tank temperature Sensor (12 m) |

- For space heating / cooling, 'DIP switch #2' should be set correctly.
- For sensing air temperature at specific area, remote temperature sensor(PQRSTA0) or wired remote controller could be choose, depending on the 'DIP switch #3' setting.  
\*please refer the "System Set-Up, DIP Switch Setting"
- Wi-Fi module(PWFMDD200/105 cm) connected to 'CN-WF' on **Hydro Kit** PCB. To increase the length between Wi-Fi modem and **Hydro Kit**, please purchase USB Extension Cable(PWYREW000, 10 m)
- In case of floor cooling, please make sure to set cooling cut off temperature for preventing condensation on the floor
- For 2 way valve control, please refer the "Accessories Installation, 2 Way valve"

| Mode    | Condition       | 2-way valve |
|---------|-----------------|-------------|
| Cooling | FCU – 'Not use' | Open        |
|         | FCU – 'Use'     | Close       |
| Heating | None            | No control  |

**NOTE**

- Balancing valve with flow meter is recommended to ensure 100 % of the nominal flow. If the water flow rate is too low or High, PHEX could be frozen and burst or capacity could be reduced.

<sup>1)</sup> Cooling operation is only available for Medium temperature **Hydro Kit**.

## 2) Water Tank(DHW) Installation

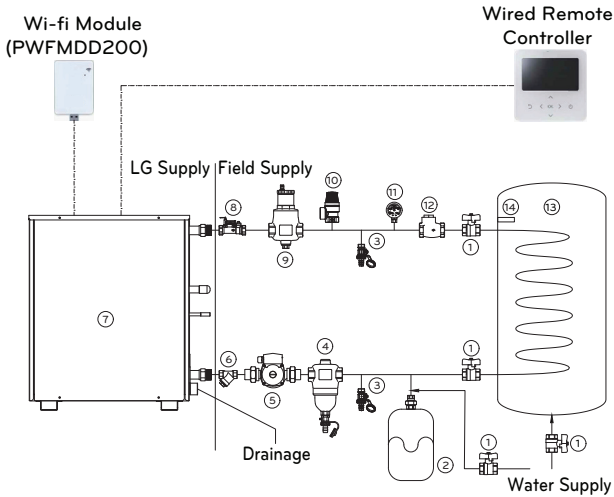

|   |   |    |                                      |
|---|---|----|--------------------------------------|
| 1 | Shut-Off valve  | 8  | Balancing valve with flow meter      |
| 2 | Expansion tank  | 9  | Automatic air separator              |
| 3 | Service port(Drain valve)                                   | 10 | Pressure safety relief valve         |
| 4 | Magnetic filter (Mandatory with Corrosive material of pipe) | 11 | Pressure meter                       |
| 5 | Water Pump  | 12 | Check valve                          |
| 6 | Strainer  | 13 | Buffer Tank                          |
| 7 | Flow switch (included in product)                           | 14 | Water Tank temperature Sensor (12 m) |

- For water tank(DHW) operation, DIP switch #2 in **Hydro Kit** PCB should be set correctly, please refer the "System Set-Up, DIP Switch Setting"
- Wi-Fi module(PWFMD200, 105 cm) is connected to 'CN-WF" on **Hydro Kit** PCB.  
To increase the length between Wi-Fi modem and **Hydro Kit**, please purchase USB Extension Cable(PWYREW000, 10 m)
- DHW(Sanitary water) tank should be located at the flat place.
- Water quality should comply with EN 98/83 EC Directives.
- DHW(Sanitary water) tank (indirect heat exchange), do not use anti water-freezing treatment like ethylene glycol.
- It is highly recommend to wash out inside of the DHW(Sanitary water) tank after installation for clean hot water.
- Near the DHW(Sanitary water) tank , there should be water supply and water drain for easy access and maintenance.

### Water tank temperature sensor(14) connection

If hot water mode is used, make sure to install sensor to water tank.

- Make PT 1/2inch female bolt hole in the water tank and install sensor in the water tank.
- Push the sensor into the hole of the sensor holder cap.
- Lock the sensor holder cap.
- Maximum length of water tank temperature sensor is 12 m.

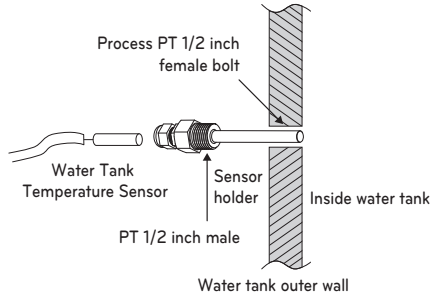

## 3) Water Tank(DHW) + Floor Heating Installation(Default)

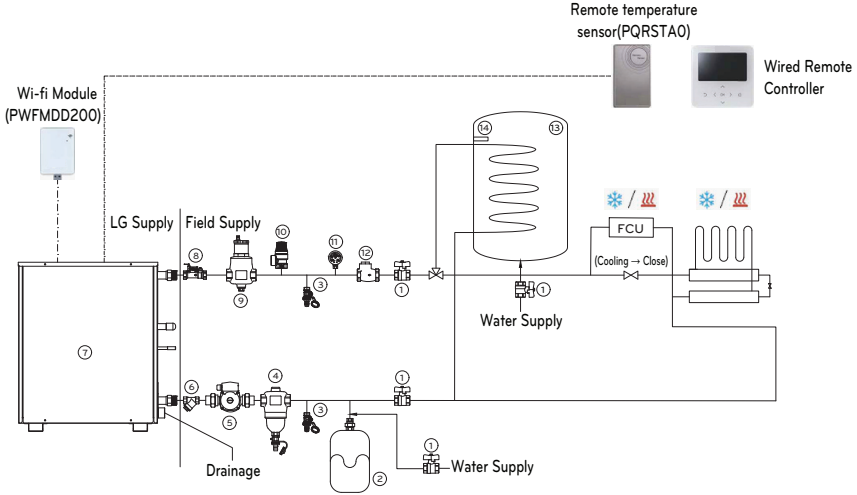

|   |                                   |    |   |
|---|-----------------------------------|----|---|
| 1 | Shut-Off valve                    | 8  | Balancing valve with flow meter         |
| 2 | Expansion tank                    | 9  | Automatic air separator                 |
| 3 | Service port(Drain valve)         | 10 | Pressure safety relief valve            |
| 4 | Magnetic filter(Recommended)      | 11 | Pressure meter                          |
| 5 | Water Pump                        | 12 | Check valve                             |
| 6 | Strainer                          | 13 | DHW <sup>1)</sup> (Sanitary Water) Tank |
| 7 | Flow switch (Included in product) | 14 | Water Tank temperature Sensor (12 m)    |

- For DHW / Floor Heating operation , 'DIP switch #2' should be set correctly.
- For sensing air temperature at specific area, remote temperature sensor(PQRSTA0) or wired remote controller could be choose, depending on the 'DIP switch #3' setting.  
\*please refer the "System Set-Up, DIP Switch Setting"
- Wi-Fi module(PWFMDD200/105 cm) connected to 'CN-WF' on **Hydro Kit** PCB. To increase the length between Wi-Fi modem and **Hydro Kit**, please purchase USB Extension Cable(PWYREW000, 10 m)
- In case of floor cooling, please make sure to set cooling cut off temperature for preventing condensation on the floor
- For 3-way, 2-way valve control, please refer the "Accessories Installation"

| Mode    | Condition        | 3-way valve direction     | 2-way valve |
|---------|------------------|---------------------------|-------------|
| Cooling | FCU – 'Not use'  | Under Floor               | Open        |
|         | FCU – 'Use'      | Under Floor               | Close       |
| Heating | Priority – 'DHW' | DHW / Sanitary Water Tank | No control  |
|         | Priority – 'UFH' | Under Floor               | No control  |

**NOTE**

- The Heating operation mode of the hot water tank is not a mode selection by the remote controller, it changes the 3-way valve direction to Water Tank base on the water tank temperature.
- It is impossible to operate Hot water(DHW) during cooling mode.

## 4) Water Tank(DHW) + Floor Heating + Solar booster Installation

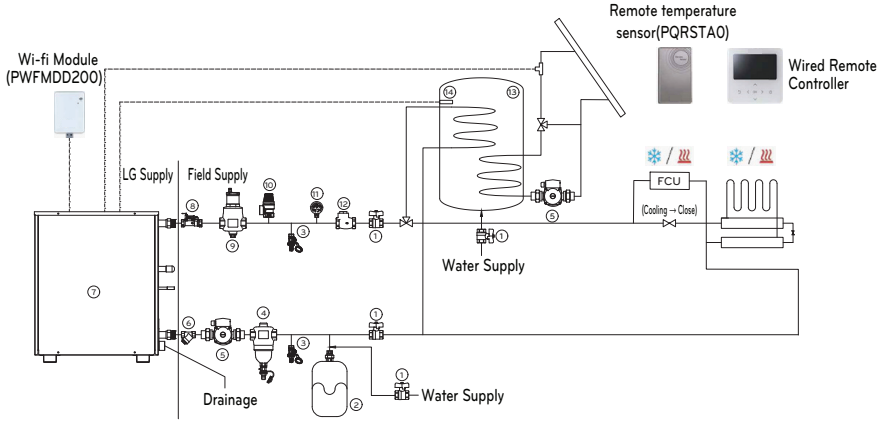

|   |                                   |    |  |
|---|-----------------------------------|----|--|
| 1 | Shut-Off valve                    | 9  | Automatic air separator                  |
| 2 | Expansion tank                    | 10 | Pressure safety relief valve             |
| 3 | Service port(Drain valve)         | 11 | Pressure meter                           |
| 4 | Magnetic filter(Recommended)      | 12 | Check valve                              |
| 5 | Water Pump                        | 13 | DHW <sup>(1)</sup> (Sanitary Water) Tank |
| 6 | Strainer                          | 14 | Water Tank temperature Sensor (12 m)     |
| 7 | Flow switch (Included in product) | 15 | Solar panel                              |
| 8 | Balancing valve with flow meter   |    |  |

- For DHW / Floor Heating and Solar booster operation, 'DIP switch #2' should be set correctly.
- For sensing air temperature at specific area, remote temperature sensor(PQRSTA0) or wired remote controller could be choose, depending on the 'DIP switch #3' setting.  
\*please refer the "System Set-Up, DIP Switch Setting"
- Wi-Fi module(PWFMD200/105cm) connected to 'CN-WF' on **Hydro Kit** PCB. To increase the length between Wi-Fi modem and **Hydro Kit**, please purchase USB Extension Cable(PWYREW000, 10 m)
- In case of floor cooling, please make sure to set cooling cut off temperature for preventing condensation on the floor
- DHW(Sanitary water) tank should be located at the flat place.
- Water quality should comply with EN 98/83 EC Directives.
- DHW(Sanitary water) tank (indirect heat exchange), do not use anti water-freezing treatment like ethylene glycol.
- It is highly recommend to wash out inside of the DHW(Sanitary water) tank after installation for clean hot water.
- Near the DHW(Sanitary water) tank , there should be water supply and water drain for easy access and maintenance.
- For 2-way or 3-way valve control, please refer the "Accessories Installation".

### How to install Solar Thermal Kit (PHLLA)

- Step 1.** Check the diameter of pre-installed pipes. (symbol Ⓐ and Ⓑ)
- Step 2.** If the diameter of pre-installed pipes is different from diameter of solar thermal kit, it is necessary to reduce or extend of pipe diameter.
- Step 3.** After Step 2, connect the pipe and solar thermal kit.
- Step 4.** Connect solar thermal sensor to 'CN\_TH4'(Red connector) of the indoor unit PCB.  
If the water tank sensor is connected, disconnect the sensor from PCB first.

#### DHW tank, additional information

If a Non-Stainless DHW tank is used there will be a coating inside the tank to protect this tank against corrosion.

The corrosion protection is done by an anode which is mounted inside the tank.

This anode is protecting the internal tank against corrosion which could lead to leakage and contaminated water inside the tank, the anode will increase the lifetime of the DHW tank.

#### When to replace the anode?

The lifetime of an anode itself is based on the water quality inside the country.

Depending on the used DHW tank, the tank can be equipped with an anode tester.

If the DHW does not have an anode tester manually the anode must be inspected and replaced every 3-5 years if needed.

#### What is an anode?

An anode protects the DHW tank against corrosion.

It consists of a bar of magnesium oxide.

A correct working anode is crucial to increase the lifetime of a Non-stainless steel DHW tank while it makes the tank cathodic and prevents against corrosion.

## Water Quality

Water quality should be complied with EN 98/83 EC Directives.  
Detailed water quality condition can be found in EN 98/83 EC Directives.

### CAUTION

- If the product is installed at existing hydraulic water loop, it is important to clean hydraulic pipes to remove sludge and scale.
- Installing sludge strainer in the water loop is very important to prevent performance degrade.
- Chemical treatment to prevent rust should be performed by installer.
- It is strongly recommended to install an additional filter on the heating water circuit. Especially to remove metallic particles from the heating piping, it is advised to use a magnetic or cyclone filter, which can remove small particles. Small particles may damage the unit and will NOT be removed by the standard filter of the heat pump system.

## Frost protection

In areas of the country where entering water temperatures drop below 0 °C, the water pipe must be protected by using an approved antifreeze solution. Consult your **Hydro Kit** unit supplier for locally approved solutions in your area. Calculate the approximate volume of water in the system. (Except the **Hydro Kit** unit.) And add six liters to this total volume to allow for the water contained in **Hydro Kit** unit.

| Type of Antifreeze | Minimum Temperature for Freeze Protection |               |              |               |                |
|--------------------|---|---------------|--------------|---------------|----------------|
|                    | 15 °C(59 °C) ~ -5 °C(23 °F)               | -10 °C(14 °C) | -15 °C(5 °C) | -20 °C(-4 °C) | -25 °C(-13 °C) |
| Ethylene glycol    | 12 %                                      | 20 %          | 30 %         | -             | -              |
| Propylene glycol   | 17 %                                      | 25 %          | 33 %         | -             | -              |
| Methanol           | 6 %                                       | 12 %          | 16 %         | 24 %          | 30 %           |

If you use frost protection function, change DIP switch setting and input the temperature condition in Installation mode of remote controller. Refer to page 109 and 161.

### CAUTION

- Use only one of the above antifreeze.
- If a antifreeze is used, pressure drop and capability degradation of the system can be occurred.
- If one of antifreezes is used, corrosion can be occurred. So please add corrosion inhibitor.
- Please check the concentration of the antifreeze periodically to keep same concentration.
- When the antifreeze is used (for installation or operation), take care to ensure that antifreeze must not be touched.
- Ensure to respect all laws and norms of your country about Anti-freeze usage.

## Preparation for Piping

- Main cause of gas leakage is defect in flaring work. Carry out correct flaring work in the following procedure.
- Use the de-oxidised copper as piping materials to install.

### Step 1. Cut the pipes and the cable.

- Use the accessory piping kit or the pipes purchased locally.
- Measure the distance between the indoor unit and the outdoor unit.
- Cut the pipes a little longer than measured distance.
- Cut the cable 1.5 m longer than the pipe length.

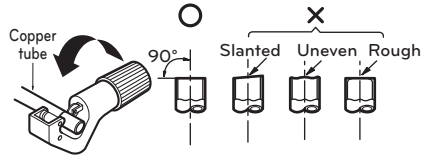

### Step 2. Burrs removal

- Completely remove all burrs from the cut cross section of pipe/tube.
- Put the end of the copper tube/pipe to downward direction as you remove burrs in order to avoid to let burrs drop in the tubing.

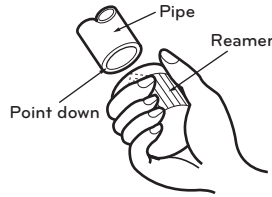

### Step 3. Putting nut on

- Remove flare nuts attached to indoor and outdoor units, then put them on pipe/tube having completed burr removal. (Not possible to put them on after flaring work)

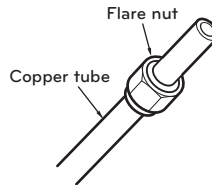

### Step 4. Flaring work.

- Carry out flaring work using dedicated flaring tool for R-410A refrigerant as shown below.

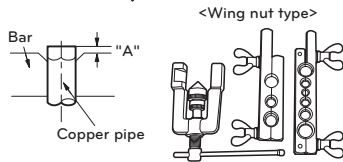

| Pipe diameter<br>[inch(mm)] | A inch (mm)        |                   | Clutch type |
|-----------------------------|--------------------|-------------------|-------------|
|                             | Wing nut type      | Clutch type       |             |
| 1/4 (6.35)                  | 0.04~0.05(1.1~1.3) | 0~0.02<br>(0~0.5) |             |
| 3/8 (9.52)                  | 0.06~0.07(1.5~1.7) |                   |             |
| 1/2 (12.7)                  | 0.06~0.07(1.6~1.8) |                   |             |
| 5/8 (15.88)                 | 0.06~0.07(1.6~1.8) |                   |             |
| 3/4 (19.05)                 | 0.07~0.08(1.9~2.1) |                   |             |

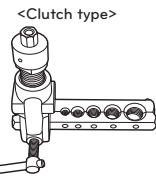

- Firmly hold copper tube in a bar(or die) as indicated dimension in the table above.

### Step 5. Check

- Compare the flared work with right figure.
- If flare is seemed to be defective, cut off the flared section and do flaring work again.

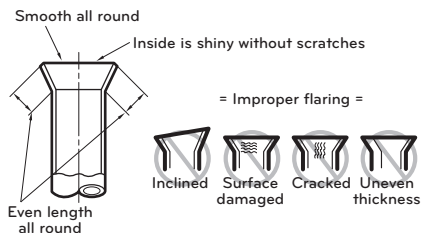

## Electrical Wiring

### General Consideration

Followings are should be considered before beginning indoor unit wiring.

- Field-supplied electrical components such as power switches, circuit breakers, wires, terminal boxes, etc should be properly chosen with compliance with national electrical legislation or regulation.
- Make it sure that supplied electricity is enough to operate the product including outdoor unit, electric heater, water tank heater, etc. The capacity of fuse also selected according to the power consumption.
- The main electricity supply should be dedicated line. Sharing main electricity supply with other devices such as washing machine or vacuum cleaner is not permitted.
- The installation of a residual current device(RCD) having a rated residual operating current not exceeding 30 mA is advisable.

### CAUTION

- Before starting wiring job, the main electricity supply should be turned off until wiring is completed.
- When adjusting or changing wiring, the main electricity supply should be turned off and ground wire should be connected securely.
- Installation place should be free from the attack of wild animal. For example, mice's wire attacking or frog's entering into the indoor unit may cause critical electrical accident.
- All power connections should be protected from dew condensation by thermal insulation.
- All electrical wiring should comply with national or local electrical legislation or regulation.
- The ground should be connected exactly. Do not earth the product to the copper pipe, steel fence at the veranda, city water outlet pipe, or any other conductivity materials.
- Fix all cable using cord clamp tightly. (When cable is not fixed with cord clamp, use additionally supplied cable ties.)

Remove the box cover of electric parts and connect the wiring.

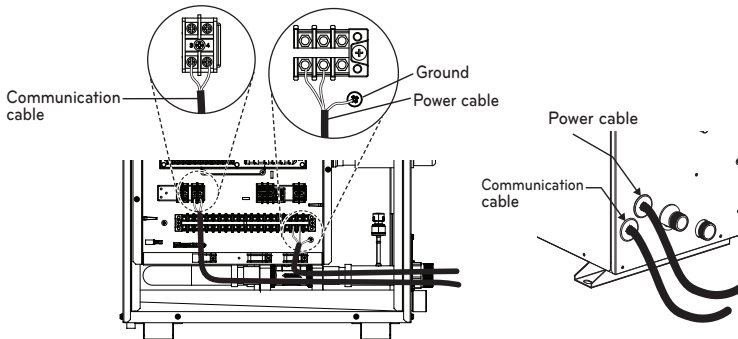

### CAUTION

When connecting the power and communication cable, always use the terminal connector. Make sure to tighten so that the screw of the terminal does not get loose.

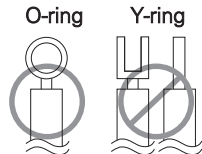

## Wiring Connection

Connect the wires to the terminals on the control board individually according to the outdoor unit connection.

- Ensure that the wire color of the outdoor unit and terminal No. are same as those of the indoor unit respectively.

### Terminal Block Information

Symbols used below pictures are as follows :

- L, L1, L2 : Live (230 VAC)
- N : Neutral (230 VAC)
- BR : Brown, WH : White, BL : Blue, BK : Black

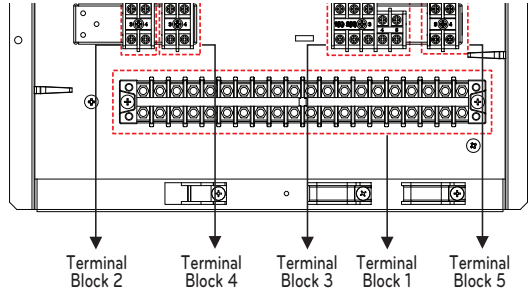

### Terminal Block 1 ~ 5

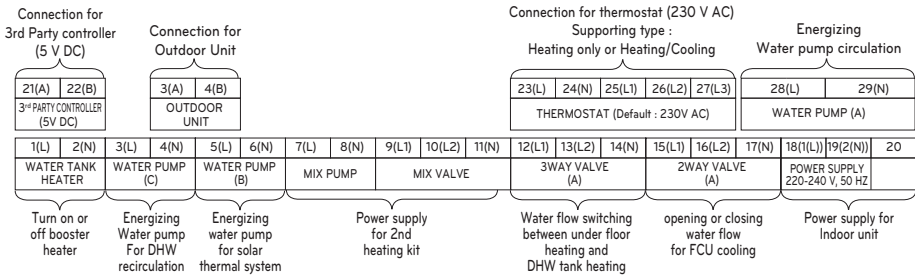

## ⚠ WARNING

Make sure that the screws of the terminal are free from looseness.

## ⚠ CAUTION

Be sure to test the power line and communication line for incorrect wiring before power is applied.

- 1) If the power line and communication line are swapped over, the product will be damaged.
- 2) Incorrect wiring confirmation test method : Measure the resistance across the power terminals (L,N) using a multi meter.
  - Resistance value of a normal connection: 1 mΩ or more
  - Incorrect wiring resistance value: 500 mΩ or less

## ! CAUTION

After the confirmation of the above conditions, prepare the wiring as follows:

1. Use a separate power source only for the air conditioner.  
For the method of wiring, follow the circuit diagram on the inner side of control box cover.
2. Install a circuit breaker between power source and the unit.
3. Make sure that wiring screws are fastened. Screw could be loose by vibration during transportation. (If screws are loose, wires could be burnt-out)
4. Check the Specification of power source
5. Make sure the electrical capacity is sufficient.
6. Starting voltage should be maintained above 90 percent of the rated voltage marked on the name plate.
7. Make sure the cable thickness matches the power sources specification.  
(Please note the relation between cable length and thickness.)
8. Do not install the earth leakage breaker in a place which is wet or moist.  
Water or moisture may cause a short circuit.
9. The following troubles could be caused by voltage drop-down.
  - Vibration of a magnetic switch, damage on the contact point there of, (fuse breaking), disturbance to the normal function of a an overload protection device.
  - Proper starting power is not given to the compressor.
10. Before supplying power to the indoor unit, please check the wiring of the power and communication lines.
11. If the supply cord is damaged, it must be replaced by the manufacturer, its service agent or similarly qualified persons in order to avoid a hazard.

### Rating of circuit breakers

|        | The thickness of Minimum wire (mm <sup>2</sup> ) |             | Leakage circuit breaker    |
|--------|--|-------------|----------------------------|
|        | Main power wire                                  | Ground wire |                            |
| 1 Unit | 2.5 ~ 6  | 2.5         | < 30 ~ 50 A 100 mA 0.1 S   |
| 2 Unit | 10 ~ 16  | 2.5         | < 75 ~ 100 A 100 mA 0.1 S  |
| 3 Unit | 25 ~ 35  | 4           | < 125 ~ 150 A 100 mA 0.1 S |
| 4 Unit | 70   | 6           | < 175 ~ 200 A 100 mA 0.1 S |

## Connecting Cables

### Types of the cables

| Classification               | Types                   | Cables cross section |
|------------------------------|-------------------------|----------------------|
| Power cable(H07RN-F)         | mm <sup>2</sup> x cores | 2.5 x 3              |
| Communication cable(VCTF-SB) | mm <sup>2</sup> x cores | 1.0~1.5 x 2          |

### The distance between communication cable and power cable

- If the power cable and communication cable are tied together, system malfunction may occur with electrostatic, electromagnetic combination effect causing the interference signal. If communication cable is connected along with power cable, secure at least 50 mm distance between indoor unit power cable and communication cable.

It is the value with the assumption of the length of the parallel cable as 100 m. If it is longer than 100 m, it shall be calculated again with proportional to the added length.

If the distortion in the waveform of the power still occurs despite securing the distance, increase the distance.

- ※ When several power cables are inserted into the transmission line, or tied together, make sure to consider the following issues.
  - Power cables and communication cable shall not be in the same transmission line.
  - Power cables and communication cable shall not be tied together.



## WARNING

- Are all of the indoor units and outdoor units grounded?
- If grounding is not properly done, there is a risk of electric shock. Grounding must be done by a qualified technician.
- Consider the surrounding conditions(surrounding temperature, direct sunlight, rain water, etc.) when wiring the cable.
- The thickness of the power cable is the minimum thickness of metal conductor cable. Use thicker cable considering the voltage drop.

## Installation of Wired Remote Controller

- Please fix tightly using provided screw after placing remote controller setup board on the place where you like to setup.
  - Please set it up not to bend because poor setup could take place if setup board bends.
  - Please set up remote controller board fit to the reclamation box if there is a reclamation box.
  - Install the product so as not to make a gap with the wall side and to prevent shaking after the installation.

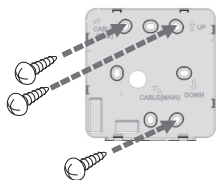

<4 socket reclamation box installation>

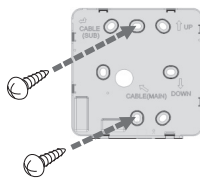

<2 socket reclamation box installation>

- Can set up Wired remote controller cable into three directions.

- Setup direction: the surface of wall reclamation, upper, right
- If setting up remote controller cable into upper and right side, please set up after removing remote controller cable guide groove.
- ※ Remove guide groove with long nose.
- Reclamation to the surface of the wall.

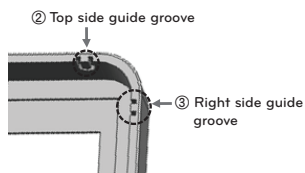
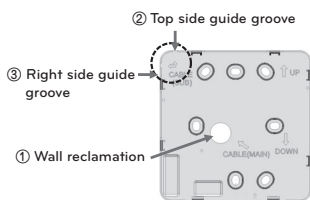

- Please fix remote controller upper part into the setup board attached to the surface of the wall, as the picture below, and then, connect with setup board by pressing lower part.

- Please connect not to make a gap at the remote controller and setup board's upper and lower, right and left part.
- Before assembly with the installation board, arrange the Cable not to interfere with circuit parts.

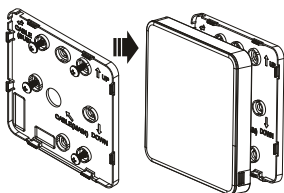

4. When separating remote controller from setup board, as the picture below, after inserting into the lower separating hole using screw driver and then, spinning clockwise, remote controller is separated.
- There are two separating holes. Please individually separate one at a time.
  - Please be careful not to damage the inside components when separating.

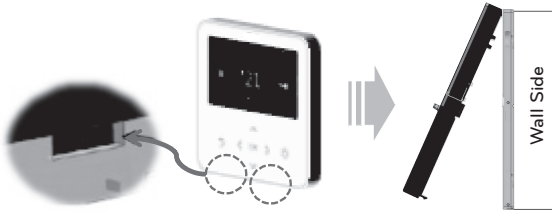

5. Please connect indoor unit and remote controller using connection cable.

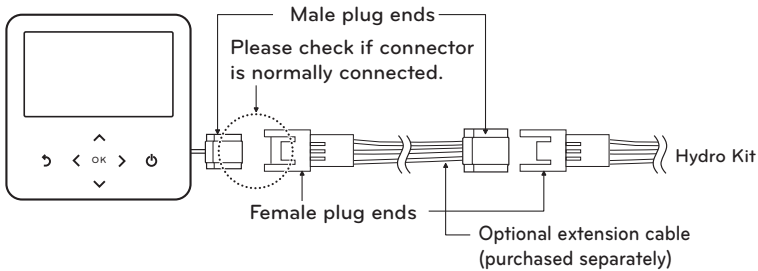

6. Please use extension cable if the distance between wired remote controller and indoor unit is more than 10 m.  
 Extension cable(10 m) model name : PZCWRC1

**CAUTION**

When installing the wired remote controller, do not bury it in the wall. (It can cause damage in the temperature sensor.)

Do not install the cable to be 50 m or above. (It can cause communication error.)

- When installing the extension cable, check the connecting direction of the connector of the remote controller side and the product side for correct installation.
- If you install the extension cable in the opposite direction, the connector will not be connected.
- Specification of extension cable: 2547 1007 22# 2 core 3 shield 5 or above.

## Independent Power Module

Independent power module is required to protect a plate heat exchanger burst. When the outdoor unit is operating, if **Hydro Kit** is suddenly powered off, a plate heat exchanger burst may happen during oil-return and defrosting cycle in cooling mode.

### How to install Independent Power Module

**Step 1.** Open the front panel of the control box

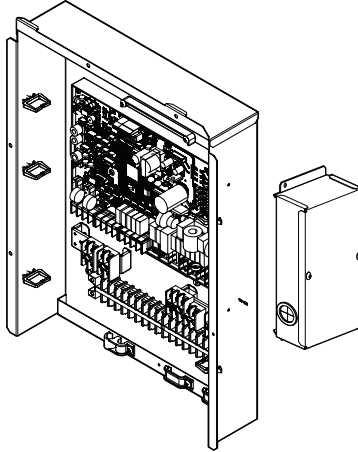

**Step 2.** Assemble the cover of independent power module, fix it tightly with bolts and connect wires.

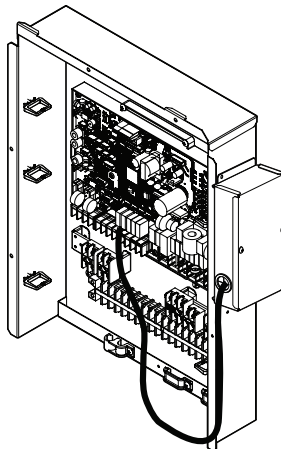

## How to wire Independent Power Module

**Step 1.** Turn the power off using circuit breaker.

**Step 2.** Disconnect the EEV cable of the indoor units PCB(CN-EEV)

**Step 3.** Connect the independent power kit(CN-EEV/LOAD) to the indoor units EEV, using harness 1.

**Step 4.** Connect the independent power kit(CN-EEV/MAIN) to the indoor units PCB (CN\_EEV / CN\_IPM), using harness 2.

**Step 5.** Supply the power.

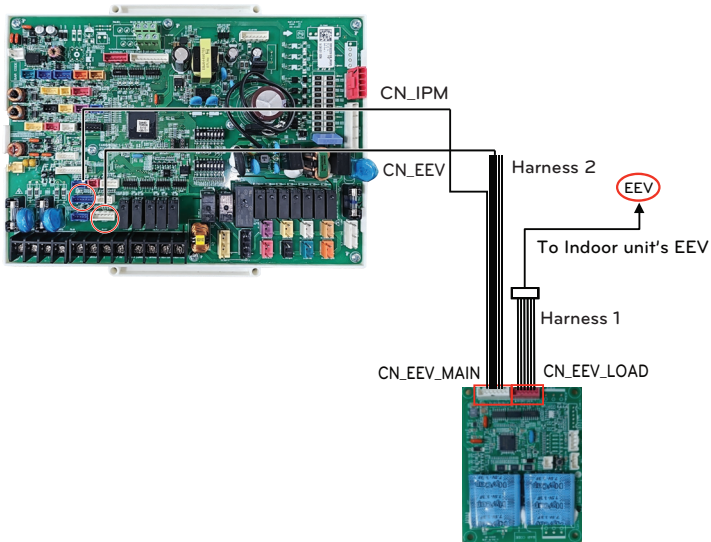

### ⚠ WARNING

- The wire should not be exposed to the outside otherwise it may lead to the malfunction of the independent power kit due to wire damage.
- Wrong wiring also causes the malfunction of the independent power kit or damage to it.
- Power should be supplied more than 20 minutes continuously in order to operate the independent power kit correctly. Otherwise, the independent power kit can not fully close the EEV due to the lack of the charging power.

### NOTE

For more detailed information, refer to the installation manual of Independent Power Module.

# ACCESSORIES INSTALLATION

**Hydro Kit** can interface to various accessories to extend its functionality and to improve user convenience. In this chapter, specifications about supported 3rd party accessories and how to connect to **Hydro Kit** is introduced.

It is noted that this chapter only deal with 3rd party accessories. For accessories supported by LG Electronics, please refer to installation manual of each accessories.

## ⚠ CAUTION

- Install the drain pan when cooling.
- If not installed, water may form.
- Please refer to separate installation manual when installing drain pan.

## Before Installation

### ⚠ WARNING

Followings should be kept before installation

- Main power must be turned off during installing 3rd party accessories.
- 3rd party accessories should be comply with supported specification.
- Proper tools should be chosen for installation.
- Never do installation with wet hands.

## Thermostat

Thermostat is generally used to control the product by air temperature. When thermostat is connected to the product, the product operation is controlled by the thermostat.

### Installation condition

### ⚠ CAUTION

- USE 220-240 V~ Thermostat
- Some electro-mechanical type thermostat has internal delay time to protect compressor. In that case, mode change can takes time more than user's expectation. Please read thermostat manual carefully if the unit does not response quickly.
- Setting temperature range by thermostat can be different with that of the unit. The heating or cooling set temperature should be chosen within the setting temperature range of the unit.
- It is highly recommended that the thermostat should be installed where space heating is mainly applied.

Following location should be avoid to secure proper operation :

- Height from floor is approximately 1.5 m.
- Thermostat can not be located where the area may be hidden when door is open.
- Thermostat can not be located where external thermal influence may be applied. (such as above heating radiator or open window)



## How to wire thermostat

Follow below procedures Step 1 ~ Step 3.

**Step 1.** Uncover front cover of the unit and open the control box.

**Step 2.** Identify the power specification of the thermostat. If it is 220-240 V~, go to Step 3.

**Step 3.** Find terminal block and connect wire as below.

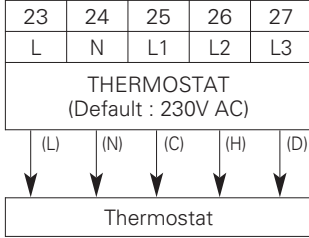

(L) : Live signal from PCB to thermostat

(N) : Neutral signal from PCB to thermostat

(C) : Cooling signal from thermostat to PCB

(H) : Heating signal from thermostat to PCB

(D) : DHW Heating signal from thermostat to PCB

### ⚠ WARNING

Mechanical type thermostat.

Do not connect wire (N) as mechanical type thermostat does not require electric power supply.

### ⚠ CAUTION

Do not connect external electric loads.

Wire (L) and (N) should be used only for operation Electric type thermostat.

Never connect external electric loads such as valves, fan coil units, etc. If connected, Main PCB (Heater) can be seriously damaged.

## Final check

- DIP switch setting :  
Set DIP switch No. 8 to 'ON'. Otherwise, the unit can not recognize the thermostat.
- Remote Controller :
  - 'Thermostat' text is displayed on the remote controller.
  - Button input is prohibited.

## DHW Tank

To establish DHW circuit, 3way valve and DHW tank kit is required. If solar thermal system is pre-installed at the installation field, solar thermal kit is required to interface solar thermal system – to – DHW tank – to – **Hydro Kit**

### Installation condition

Installing sanitary water tank requires following considerations :

- Sanitary water tank should be located at the flat place.
- Water quality should be complied with EN 98/83 EC directives.
- As this water tank is sanitary water tank (indirect heat exchange), do not use anti water-freezing treatment like ethylene glycol.
- It is highly recommend to wash out inside of the sanitary water tank after installation. It ensures generating clean hot water.
- Near the sanitary water tank there should be water supply and water drain to easy access and maintenance.
- Set the maximum value of the temperature control device of sanitary tank.

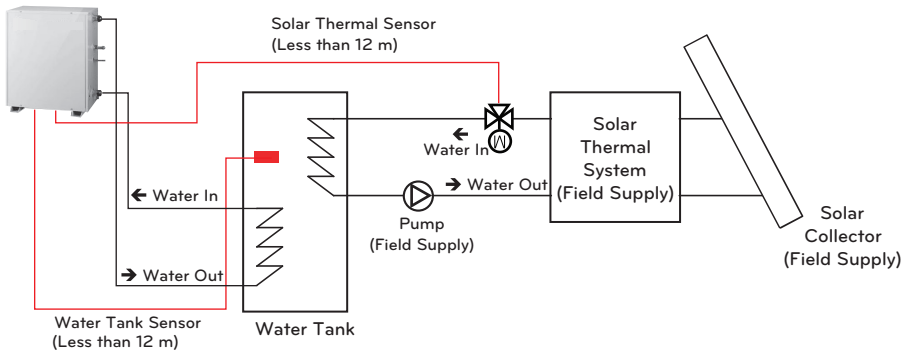

## General Information

**Hydro Kit** supports following 3way valve.

| Type                         | Power    | Operating Mode   | Supported |
|------------------------------|----------|--|-----------|
| SPDT <sup>1)</sup><br>3-wire | 230 V AC | Selecting Flow A <sup>2)</sup> between Flow A and Flow B | Yes       |
|                              |          | Selecting Flow B <sup>3)</sup> between Flow A and Flow B | Yes       |

(1) : SPDT = Single Pole Double Throw. Three wires consist of Live1 (for selecting Flow A), Live 2 (for selecting Flow B), and Neutral (for common).

(2) : 'Flow A' means water flow from the unit to under floor water circuit.

(3) : 'Flow B' means water flow from the unit to DHW tank.

## ! WARNING

Installing recirculation pump

When **Hydro Kit** is used with DHW tank, it is **STRONGLY** recommended to install recirculation pump to prevent flooding out cold water at the end of hot water supply and to stabilize the water temperature inside DHW tank

- The recirculation pump should be operated when DHW demand is not required. Therefore, external time scheduler to determine when the recirculation pump should turn on and turn off is required.

- The operating duration time of the recirculation pump is calculated as follow :

Duration time [minute] =  $k \times V \times R$

k : 1.2 ~ 1.5 is recommended. (If distance between pump and tank is far, then choose high number)

V : Volume of sanitary water tank [liter]

R : Water flow rate of pump [liter per minute], which is determined by pump performance curve.

- The pump operating start time should be prior to the sanitary water demand.

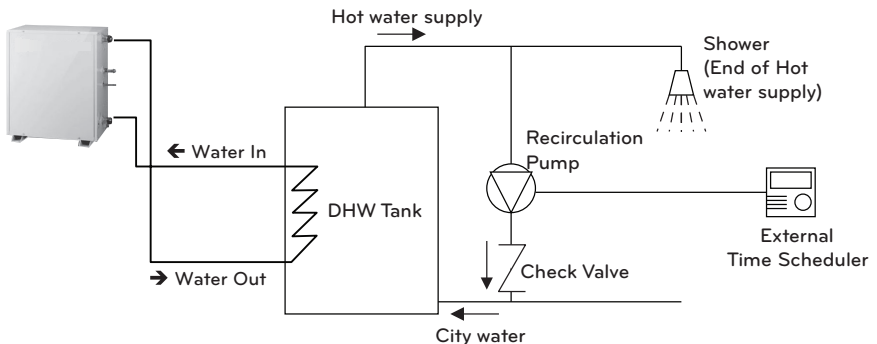

## How to Wire DHW Tank Heater

**Step 1.** Uncover heater cover of the DHW tank. It is located side of the tank.

**Step 2.** Find terminal block and connect wires as below. Wires are field-supplied item.

(L) : Live signal from PCB to Heater.

(N) : Neutral signal from PCB to Heater.

### ⚠ WARNING

Wire specification

- Cross-sectional area of the wire should be 6 mm<sup>2</sup>.

Adjusting thermostat temperature

- To guarantee proper operation, it is recommended to set temperature of thermostat to maximum temperature (symbol at the picture).
- 1Ø Electric Heater Model and 3Ø Electric Heater Model are set by same method as below.

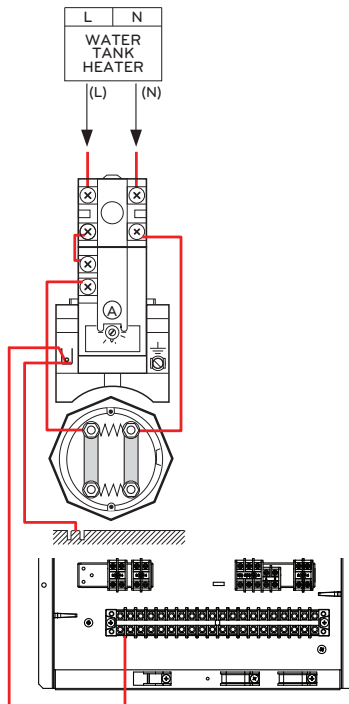

## DHW Tank Kit

This product can be used by connecting the DHW tank kit in the field. It can be utilized hot water heated by booster heater in DHW tank.

### How to install DHW tank kit

#### [Parts of DHW Tank Kit]

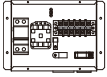

Tank kit body



Sensor

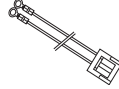

Multi harness

Temperature sensor for DHW tank is used to control hot water temperature of DHW tank. If sensor will be defective, you can purchase it separately.(Model name : PHRSTA0)

Follow below procedures step 1 ~ step 4.

**Step 1.** Uncover DHW tank kit and locate it on the wall.

**Step 2.** Connect Harness(Violet) of Main PCB assembly(TB1(6/7)) to 'CN\_TANK\_HEATER' of the Main PCB like following fig. 1.

**Step 3.** Insert DHW tank sensor to 'CN\_TH4' (Red) of the Main PCB refer as below.

**Step 4.** Connect power supply to the DHW tank kit as shown fig. 1.

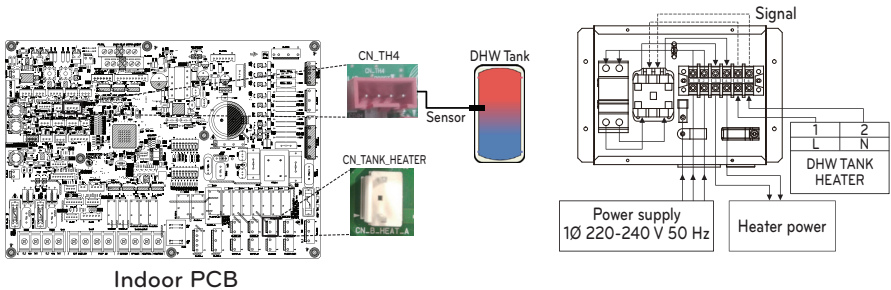

Fig. 1

## Solar Thermal Kit

This product can be used by connecting the solar thermal kit in the field. It can be utilized hot water heated by solar thermal system. End-user must be LG **Hydro Kit** solar thermal kit.

### How to Install Solar Thermal Kit

#### [Parts of Solar Thermal Kit]



Holder sensor

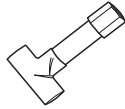

Tube Connector



Solar Thermal Sensor  
12 m(1 EA)

Follow below procedures step 1 ~ step 4.

**Step 1.** Install tube connector(it is necessary to reduce or extend diameter of pipe.) the pipe and solar thermal kit.

**Step 2.** Check if the power of the unit is turned off.

**Step 3.** Disassemble front panels and distinguish control box(Indoor) of the unit.

**Step 4.** Insert harness into PCB(CN\_TH4) fully and fix the thermal sensor into tube connector as shown below.

※ If the DHW tank sensor is connected, disconnect the sensor from PCB first.

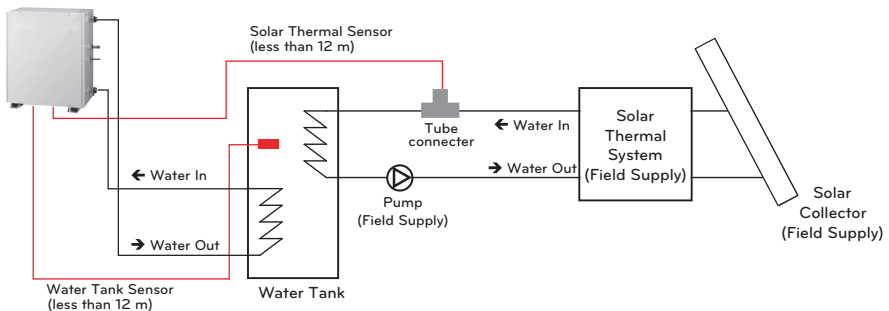
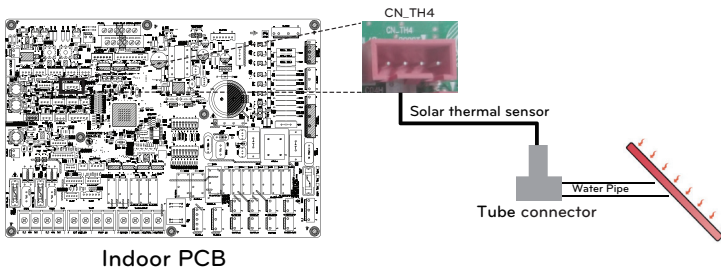

## Dry Contact

Dry Contact is a solution for automatic control of HVAC system at the owner's best. In simple words, it's a switch which can be used to turn the unit On/Off after getting the signal from external sources.

### How to install dry contact

#### [Parts of Dry contact]



Dry Contact body



Cable(for connecting with IDU)

Follow below procedures step 1 ~ step 4.

**Step 1.** Check if the power of the unit is turned off.

**Step 2.** Disassemble front panels and distinguish terminal block in Indoor PCB.

**Step 3.** Connect cable to the unit PCB(CN\_CC) fully.

**Step 4.** Then, Insert harness to the dry contact PCB(CN\_INDOOR) firmly as shown below.

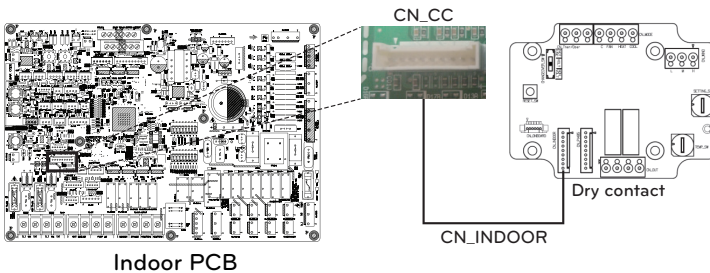

#### NOTE

- For more information about installing Dry Contact, Please refer installation manual provided with Dry Contact.
- For system set-up, please read chapter 8.(Especially function code No.6)

[Setting of Contact Signal Input]

- For input contact closure only(No power input)

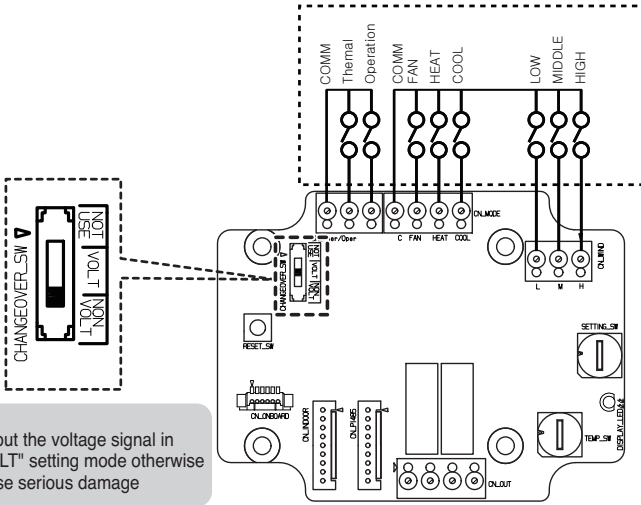

**Thermostat**  
LG does not supply this section (Field supply)

**Notes**

Do not input the voltage signal in "NON VOLT" setting mode otherwise it will cause serious damage

- For input contact voltage : DC 12 V, 24 V~

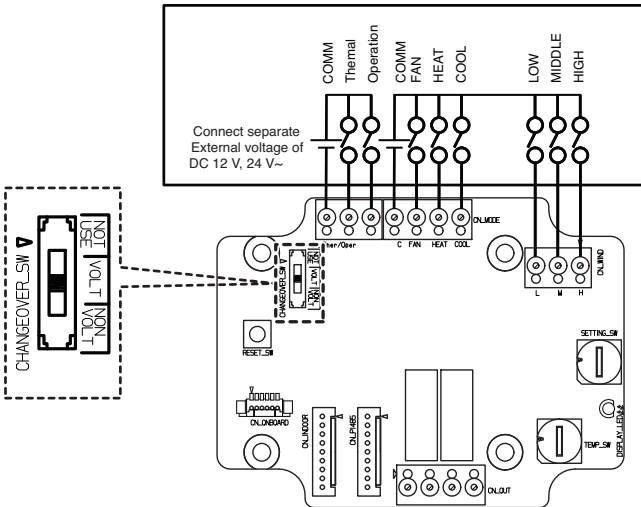

**Thermostat**  
LG does not supply this section (Field supply)

## External Controller - Setting up programmable digital input operation

If you require to operate control depending on external digital input(ON/OFF), connect cable to indoor PCB(CN\_EXT).

Follow below procedures step 1 ~ step 4.

**Step 1.** Check if the power of the unit is turned off.

**Step 2.** Disassemble front panels and distinguish control box(Indoor) of the unit

**Step 3.** Connect the external controller to PCB(CN\_EXT) completely.

**Step 4.** Connect the cable and field installation part.

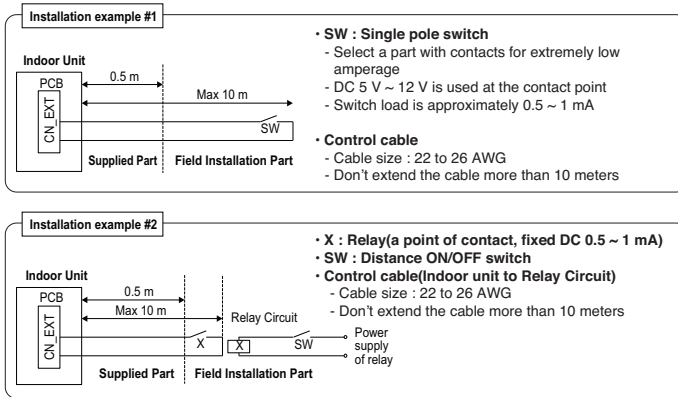
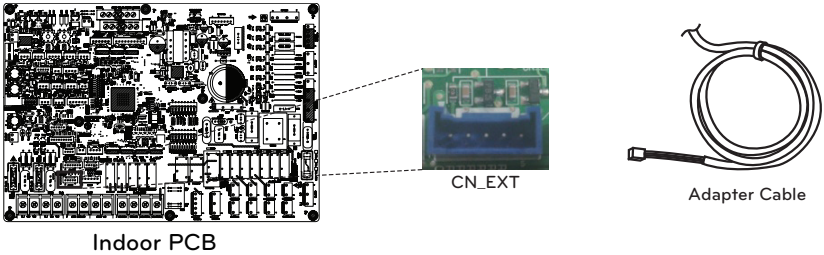

Determining the purpose of CN\_EXT

Setting value: 0 ~ 5 step Indoor CN-EXT port setting

- 0: default
- 1: Simple operation on / off
- 2: Dry contact (simple contact)
- 3: Emergency stop only for indoor unit
- 4: Reattachment / absence
- 5: Emergency stop of all indoor units (It can be set only when indoor unit has emergency stop function)

## Remote Temperature Sensor

Remote temperature sensor can be installed any place a user wants to detect the temperature.

- The function is not available for some products.

### Installation condition

Role and constraint while installation of remote air temperature sensor is very similar to that of thermostat.

- Distance between the unit and the remote air temperature sensor should be less than 15 m due to length of the connection cable of remote air temperature sensor.
- For other constraints, please refer to previous page where constraints about thermostat is described.

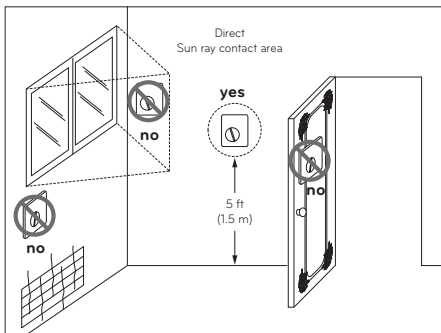

Thermostat

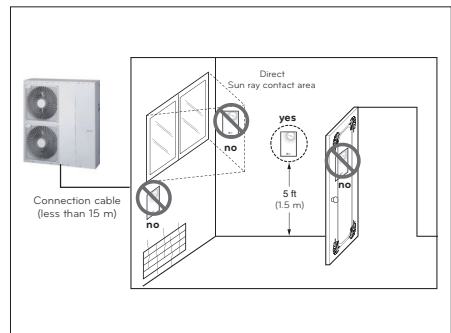

Remote Air Temperature Sensor

## How to Install Remote Temperature Sensor

[Parts of Remote Temperature Sensor]



Sensor



Screw(to fix remote sensor)

Follow below procedures step 1 ~ step 6.

**Step 1.** Decide where the remote temperature sensor is installed. Then, Determine the location and height of the fixing screws in fig. 1 (Interval between the screws : 60 mm)

**Step 2.** Check if the power of the unit is turned off.

**Step 3.** Disassemble front panels and distinguish control box(Indoor) of the unit.

**Step 4.** Insert temperature sensor into PCB(CN\_ROOM1) and fix the sensor firmly in fig. 2.

**Step 5.** The Connection wire does not matter if you change the color of the wire because of nonpolar.

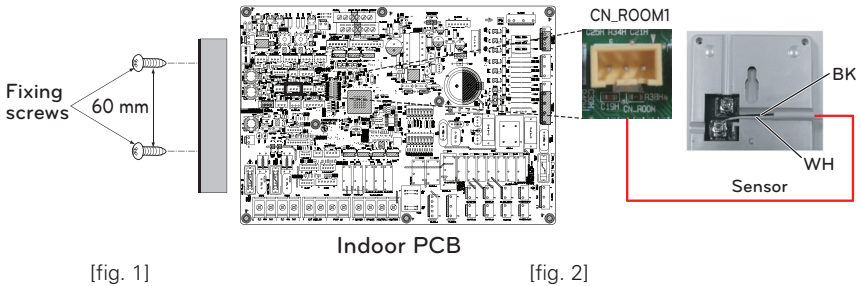

[fig. 1]

Indoor PCB

[fig. 2]

**Step 6.** Integrate the remote temperature sensor with the screws as the order of arrows.

Fixing the Remote Sensor

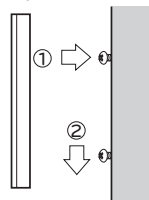

### CAUTION

- Choose the place where the average temperature can be measured for the unit operates.
- Avoid direct sunlight.
- Choose the place where the cooling/heating devices do not affect the remote sensor.
- Choose the place where the outlet of the cooling fan do not affect the remote sensor.
- Choose the place where the remote sensor isn't affected when door is open.

### NOTE

- For more information about installing Remote Temperature Sensor, Please refer installation manual provided with Remote Temperature Sensor.
- For system set-up, please read chapter 8. (Especially function code No.3)

## Solar pump

Solar pump can be required to energize water flow when solar thermal system is installed.

### How to install solar pump

Follow below procedures step 1 ~ step 4.

**Step 1.** Check if the power of the unit is turned off.

**Step 2.** Disassemble front panels and distinguish control box(Indoor) of the unit.

**Step 3.** Check if the harness(Black) is inserted fully to the indoor unit PCB (CN\_PUMP\_A4).

**Step 4.** Connect the external pump to terminal block 1(5/6).

※ It is possible to un-use solar pump depending on installation environment.

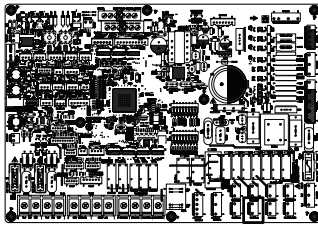

Indoor PCB



CN\_PUMP\_A4

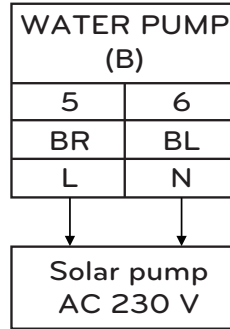

## Wi-fi Modem

Wi-fi modem enables remote system operation from smartphone. Available functions include selection of on/off, operation mode, DHW heating, temperature setup and weekly scheduling etc.

### How to install Wi-fi Modem

[Parts of Wi-fi modem]

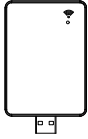

Wi-fi modem body

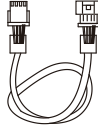

USB Cable

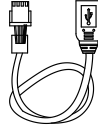

Extension Cable

Follow below procedures step 1 ~ step 5.

**Step 1.** Check if the power of the unit is turned off.

**Step 2.** Disassemble front panels and distinguish control box(Indoor) of the unit.

**Step 3.** Connect the USB cable to the indoor unit PCB (CN\_Wi-Fi ; Blue) until it clicks into place.

**Step 4.** Connect the Wi-Fi modem to the USB cable fully.

**Step 5.** Refer to the image below to install the Wi-Fi modem in the marked position.

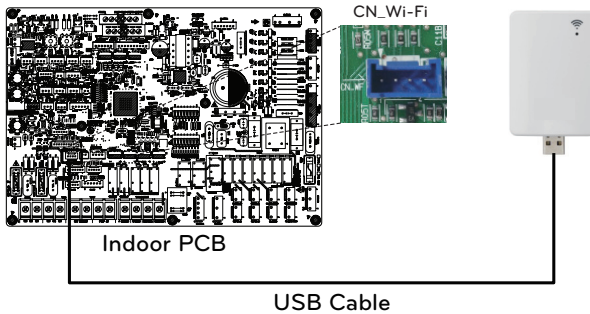

## 2Way Valve

2way valve is required to control water flow while cooling operation. Role of 2way valve is to cut off water flow into under floor loop in cooling mode when fan coil unit is equipped for cooling operation.

### General Information

**Hydro Kit** supports following 2way valve.

| Type                    | Power    | Operating Mode | Supported |
|-------------------------|----------|----------------|-----------|
| NO 2-wire <sup>1)</sup> | 230 V AC | Valve Closing  | Yes       |
|                         |          | Valve Opening  |           |
| NC 2-wire <sup>2)</sup> | 230 V AC | Valve Opening  | Yes       |
|                         |          | Valve Closing  |           |

(1) : Normal Open type. When electric power is NOT supplied, the valve is open. (When electric power is supplied, the valve is closed.)

(2) : Normal Closed type. When electric power is NOT supplied, the valve is closed. (When electric power is supplied, the valve is open.)

### How to Wire 2Way Valve

Follow below procedures Step 1 ~ Step 2.

**Step 1.** Uncover front cover of the unit.

**Step 2.** Find terminal block and connect wire as below.

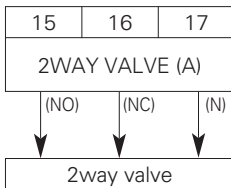

(NO) : Live signal (for Normal Open type) from PCB to 2way valve.

(NC) : Live signal (for Normal Closed type) from PCB to 2way valve.

(N) : Neutral signal from PCB to 2way valve.

### CAUTION

#### Dew Condensation

- Wrong wiring can yield dew condensation on the floor. If radiator is connected at the under floor water loop, dew condensation can be occurred on the surface of the radiator.

### WARNING

#### Wiring

- Normal Open type should be connected to wire (NO) and wire (N) for valve opening in cooling mode.
- Normal closed type should be connected to wire (NC) and wire (N) for valve closing in cooling mode.

### Final Check

- Flow direction :
  - Water should not flow into under floor loop in cooling mode.
  - To verify the flow direction, check temperature at the water inlet of the under floor loop.
  - If correctly wired, this temperatures should not be approached to 6 °C in cooling mode.

## 3Way Valve(A)

3Way Valve(A) is required to operate DHW water tank. Role of 3way valve is flow switching between under floor heating loop and water tank heating loop. Plus, it is required to operate 3<sup>rd</sup> party boiler.

### General Information

**Hydro Kit** supports following 3way valve.

| Type                         | Power      | Operating Mode  | Supported |
|------------------------------|------------|---|-----------|
| SPDT <sup>1)</sup><br>3-wire | 220-240 V~ | Selecting Flow A <sup>2)</sup> between<br>Flow A and Flow B | Yes       |
|                              |            | Selecting Flow B <sup>3)</sup> between<br>Flow A and Flow B | Yes       |

(1) : SPDT = Single Pole Double Throw. Three wires consist of Live1 (for selecting Flow A), Live 2 (for selecting Flow B), and Neutral (for common).

(2) : Flow A means 'water flow from the unit to under floor water circuit.'

(3) : Flow B means 'water flow from the unit to DHW water tank.'

### How to wire 3way valve(A)

Follow below procedures Step 1 ~ Step 2.

Step 1. Uncover front cover of the unit.

Step 2. Find terminal block and connect wire as below.

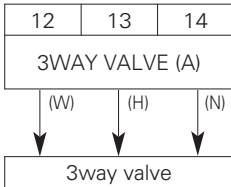

### WARNING

- 3way valve should select water tank loop when electric power is supplied to wire (W) and wire (N).
- 3way valve should select under floor loop when electric power is supplied to wire (U) and wire (N).

(W) : Live signal (Water tank heating) from PCB to 3way valve

(U) : Live signal (Under floor heating) from PCB to 3way valve

(N) : Neutral signal from PCB to 3way valve

## Final check

| No. | Check point                               | Description  |
|-----|---|--|
| 1   | Connection of Water Inlet/Outlet          | <ul style="list-style-type: none"> <li>- Check if the shut-off valves should be assembled with Water inlet and outlet pipe of the unit</li> <li>- Check the location of the water inlet/outlet water pipe</li> </ul>   |
| 2   | Hydraulic pressure                        | <ul style="list-style-type: none"> <li>- Check the pressure of supplying water by using pressure gauge inside the unit</li> <li>- Pressure of Supplying water should be Under 3.0 bar approximately</li> </ul>   |
| 3   | Water pump capacity                       | <ul style="list-style-type: none"> <li>- To secure enough water flow rate, do not set water pump capacity as Minimum.</li> <li>- It can lead unexpected flow rate error CH14.</li> </ul>   |
| 4   | Transmission line and power source wiring | <ul style="list-style-type: none"> <li>- Check if Transmission line and power source wiring are separated from each other.</li> <li>- If it is not, electronic noise may occur from the power source.</li> </ul>   |
| 5   | The power cord specifications             | <ul style="list-style-type: none"> <li>- Check the power cord specifications</li> </ul>  |
| 6   | 3Way Valve                                | <ul style="list-style-type: none"> <li>- Water should flow from Water outlet of the unit to sanitary tank Water inlet when sanitary tank heating is selected.</li> <li>- To verify the flow direction, Make sure that the water outlet temperature of the unit and water inlet temperature of sanitary Water tank are similar</li> </ul> |
| 7   | 2Way Valve                                | <ul style="list-style-type: none"> <li>- Water should not flow into under floor loop in cooling mode.</li> <li>- To verify the flow direction, check temperature at the water inlet of the under floor loop.</li> <li>- If correctly wired, this temperatures should not be approached to 6 °C in cooling mode.</li> </ul>               |
| 8   | Air Vent                                  | <ul style="list-style-type: none"> <li>- Air-vent must be located highest level of Water pipe system</li> <li>- It should be installed at the point which is easy to service.</li> <li>- It takes some times to remove air in the water system if air purge is not performed sufficiently it may occur CH14 error.</li> </ul>            |

# SYSTEM SET-UP

As **Hydro Kit** is designed to satisfy various installation environment, it is important to set up system correctly. If not configured correctly, improper operation or degrade of performance can be expected.

## DIP Switch Setting

### ! CAUTION

Turn off electric power supply before setting DIP switch

- Whenever adjusting DIP switch, turn off electric power supply to avoid electric shock.

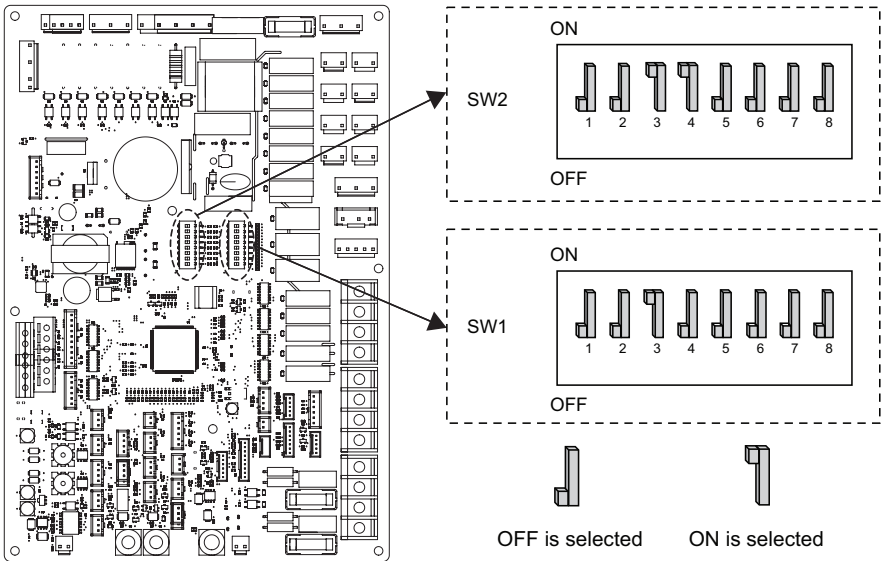

## General Information

### Indoor PCB











## DIP Switch Information

### Option Switch 2

| Description                         | Setting  |  | Default  |
|-------------------------------------|--|--|--|
| Group control                       | <br>1   | As Master  | <br>1   |
|                                     | <br>1   | As Slave   |  |
| Accessory installation information  | <br>2   | <br>3 | <br>2<br><br>3 |
|                                     | <br>2   | <br>3 |  |
|                                     | <br>2   | <br>3 |  |
| Cycle                               | <br>4   | Heating Only   | <br>4   |
|                                     | <br>4   | Heating & Cooling  |  |
| Thermostat installation information | <br>8   | Thermostat is NOT installed  | <br>8  |
|                                     | <br>8 | Thermostat is installed  |  |

## Option Switch 1

| Description     | Setting  |                                     | Default  |
|-----------------|--|-------------------------------------|--|
| MODBUS          | <br>1 | As Master<br>(LG extension modules) | <br>1 |
|                 | <br>1 | As Slave<br>(3rd party controller)  |  |
| MODBUS Function | <br>2 | REGINE                              | <br>2 |
|                 | <br>2 | Unified Open Protocol               |  |
| Antifreeze      | <br>8 | Antifreeze mode not use             | <br>8 |
|                 | <br>8 | Antifreeze mode *                   |  |

※ Only the switch in the table has a function. Others have no function.

\* Possibility to allow colder water temperature by setting.  
Bridge at CN\_ANTI\_SW must be dis-connected to enable setting.

## NOTE

**Emergency Operation**• **Definition of terms**

- Trouble : a problem which can stop system operation, and can be resumed temporarily under limited operation without certificated professional's assist.
- Error : problem which can stop system operation, and can be resumed ONLY after certificated professional's check.
- Emergency mode : temporary heating operation while system met Trouble.

• **Objective of introducing 'Trouble'**

- Not like air conditioning product, **Hydro kit** is generally operation in whole winter season without any system stopping.
- If system found some problem, which is not critical to system operating for yielding heating energy, the system can temporarily continue in emergency mode operation with end user's decision.

• **Classified Trouble**

- Trouble is classified two levels according to the seriousness of the problem : Slight Trouble and Heavy trouble
- Slight Trouble : a problem is found inside the unit. In most case, this trouble is concerned with sensor problems. The outdoor unit is operating under emergency mode operation condition which is configured by DIP switch No. 4 of the unit PCB.
- Heavy trouble : a problem is found inside the outdoor unit. As the outdoor unit has problem, the emergency mode operation is performed by electric heater located in the unit.
- Option Trouble : a problem is found for option operation such as water tank heating. In this trouble, the troubled option is assumed as if it is not installed at the system.

• **When the Hydro kit has any trouble,**

- (1) If there is not a function to judge possibility of operation : Once an error occurs mainly in indoor unit, **Hydro Kit** stops. On the other hand, remote controller allows the product to activate On/ Off operation. (On : emergency operation)
  - Slight / Heavy trouble : Heating Operable only
  - Critical trouble : Full stop
  - Treatment priority : Critical>Heavy>Slight
- (2) If there is a function to judge possibility of operation :  
Depending on the status of slight / heavy / critical trouble, pop-up phrase is guided separately on display.
  - Slight trouble : Heating/Cooling Operable
  - Heavy trouble : Heating Operable only
  - Critical trouble : Service center request

**Hydro Kit** operates when user pressed OK button on pop-up window.

**NOTE****• Duplicated trouble : Option trouble with slight or heavy trouble**

- If option trouble is occurred with slight (or heavy) trouble at the same time, the system puts higher priority to slight (or heavy) trouble and operates as if slight (or heavy) trouble is occurred.
- Therefore, sometimes DHW heating can be impossible in emergency operation mode. When DHW is not warming up while emergency operation, please check if DHW sensor and related wiring are all Ok.

**• Emergency operation is not automatically restarted after main electricity power is reset.**

- In normal condition, the product operating information is restored and automatically restarted after main electricity power is reset.
- But in emergency operation, automatic re-start is prohibited to protect the product.
- Therefore, user must restart the product after power reset when emergency operation has been running.

# SERVICE SETTING

## How to enter service setting

To enter the menu displayed at the bottom, you need to enter the service setting menu as follows.

- In the menu screen, press [ <, > (left/right) ] button to select the setting category, and press [OK] button to move to the setting list.
- In the setting list, select the service setting category, and press [OK] button to move to the service setting list.

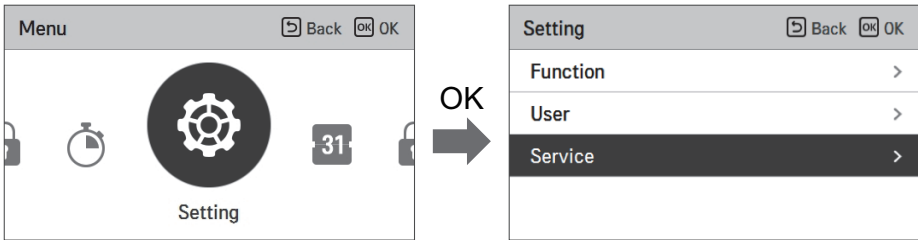

## Service setting

- You can set the product service functions.
- Some functions may not be displayed/operated in some product types.

| Menu                    | Description  |
|-------------------------|--|
| Service contact         | Check and input the service center phone number that you can call when there is service issue. |
| Model information       | View product and capacity information  |
| RMC Version Information | Check the remote controller model name and software version.                                   |
| Open Source License     | View the remote controller's open source license.  |



## Model information

Check product and capacity information to which the remote controller is connected.

- In the service setting list, select model information category, and press [OK] button to move to the detail screen.
- The unit capacity
  - $1 \text{ kWh} = 1 \text{ kBtu} * 0.29307$
  - kWh is the result calculated based on Btu, There may be a small difference between calculated and actual capacity.
  - Ex) If the unit capacity is 18 kBtu, it is displayed as 5 kWh.

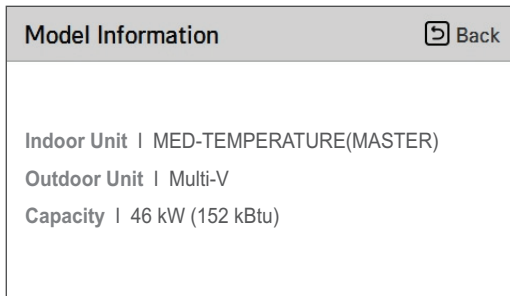
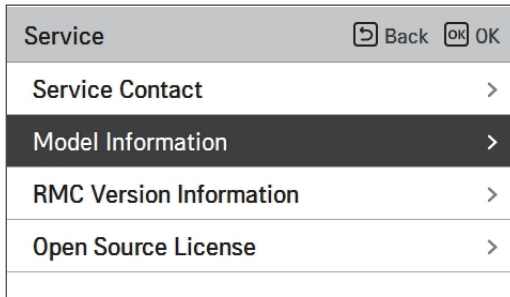

## RMC version Information

View the remote controller software version.

- In the service setting list, select the RMC version information and press [OK] button to move to the detail screen

| Service                        | Back | OK |
|--------------------------------|------|----|
| Service Contact                | >    |    |
| Model Information              | >    |    |
| <b>RMC Version Information</b> | >    |    |
| Open Source License            | >    |    |



(Example)

| RMC Version Information  | Back |
|--|------|
| Indoor Unit   Main : SAA43794506(5112)<br>EEPROM : SAA39124226(4E9C) |      |
| Outdoor Unit   -   |      |
| SW Version   3.07.3a(Master)   |      |

## Open source license

View the remote controller's open source license.

- In the service setting list, select the open source license category, and press [OK] button to move to the detail screen.

| Service                    | ⏪ Back | OK |
|----------------------------|--------|----|
| Service Contact            |        | >  |
| Model Information          |        | >  |
| RMC Version Information    |        | >  |
| <b>Open Source License</b> |        | >  |



| Open Source License  |                             | ⏪ Back |
|--|-----------------------------|--------|
| <b>LGE Open Source Software Notice</b>   |                             |        |
| Product Type   | HVAC WIRED REMOTE CONTR     |        |
| Model Number/Range   | RS3 Wired Remote Controller | 1/401  |
| Those products identified by the Product Type and Model Range above from LG Electronics, Inc. ("LGE") contain the open source software detailed below. Please refer to the |                             |        |

# INSTALLER SETTING

## How to enter installer setting

### CAUTION

The installer setting mode is the mode to set the remote controller's detail function. If the installer setting mode is incorrectly set, it may cause product failure, user's injury, or property damage. It must be set by the installation specialist with the installation license, and if it is installed or changed without installation license, all problems caused will be the responsibility of the installer, and may void the LG warranty.

- In the menu screen, press [,<,>(left/right)] button to select the setting category, and press [^ (up)] button for 3 seconds to enter the password input screen for the installer setting.
- Input the password and press [OK] button to move to the installer setting list.

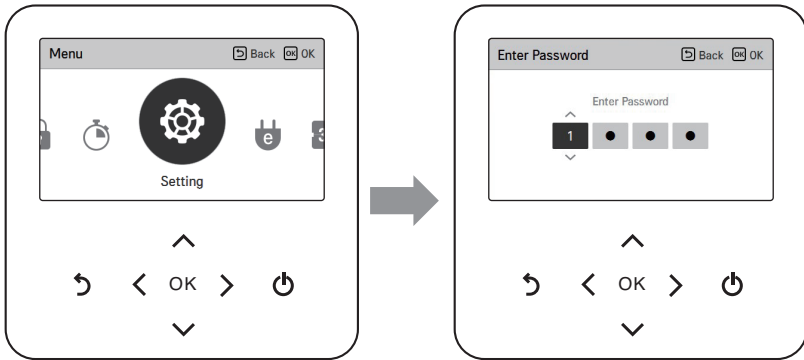

※ Installer setting password

Main screen → menu → setting → service → RMC version information → SW Version

Example) SW version : 1.00.1 a

In the above case, the password is 1001.

### NOTE

Some categories of the installer setting menu may not be available depending on the product function or the menu name may be different.

## Installer setting

- You can set the product user functions.
- Some functions may not be displayed/operated in some product types.

| Top menu      | Sub menu            | Collective menu       | Setting   | Explanation  | Setting option                     | Unit    | Default     |
|---------------|---------------------|-----------------------|---|--|------------------------------------|---------|-------------|
| CONFIGURATION | Control method      | -                     | Control method  | Definition which target the inverter should follow.<br>- Water: Water inlet or outlet setpoint defines pressure target for compressor<br>- Air: Room air setpoint defines pressure target for compressor (not recommended) | Air/Water                          | -       | Water       |
|               |                     |                       | Digital input   | With this setting a Digital input can be linked to a Circuit 1. Consequently, the signal will be used as thermo-on/off command for Circuit 1.  | CN-CC / CNTHMO / CN-EXT            | -       | CN-THMO     |
|               | Select room devices | Circuit 1             | Room air sensor option  | In case of Air- control method, either a Room sensor or the Remote controller can be used to sense the Room air temp. The device must be installed in a Reference room of Circuit 1.                                       | Room sensor/Remote controller      | -       | Room sensor |
|               |                     |                       | Digital input   | With this setting a Digital input can be linked to a Circuit 2. Consequently, the signal will be used as thermo-on/off command for Circuit 2.  | CN-CC / CNTHMO / CN-EXT            | -       | CN-THMO     |
|               | Mixing circuit      | -                     | Room air sensor option  | In case of Air- control method, either a Room sensor or the Remote controller can be used to sense the Room air temp. The device must be installed in a Reference room of Circuit 2.                                       | Room sensor/Remote controller      | -       | Room sensor |
|               |                     |                       | Mixing circuit  | Additional mixing circuit is enabled using sensor CN-MIX-OUT and 3rd-party mixer.<br>In case of 'Heating only', the Mixing valve is closed and the Mix pump is off during Cooling operation.                               | Not use/Heat & Cool / Heating only | -       | Not use     |
|               |                     |                       | Valve closing time  | Set operating time of 3rd-party mixer motor (full open → full close)   | 60...999                           | sec     | 240         |
|               | -                   | Backup heater for DHW | Defines if Backup heater is used for re-heating the DHW. To use this function the backup heater must be installed and configured by DIP switch!<br>If the DHW boost heater inside of the tank is configured too, both heaters will run in parallel! | Use / Not use  | -                                  | Not use |             |

| Top menu      | Sub Menu | Collective menu | Setting                   | Explanation   | Setting option                  | Unit | Default   |
|---------------|----------|-----------------|---------------------------|---|---------------------------------|------|-----------|
|               | -        | -               | External pump             | Setting if External pump is used and for what purpose.<br>- Use: Pump operates in parallel to Main pump.<br>- Heat & Cool: Pump operates in parallel to Main pump despite DHW heating<br>- Circuit 1: Pump is installed within Radiator circuit   | Not use/Heat&Cool/Circuit 1     | -    | Not use   |
|               | -        | -               | Boiler output             | Setting whether 3rd-party boiler is connected to TB_BOILER and enabled below Bivalent point.<br>- Remark: The boiler won't be controlled actively. Only it is released and must operate according its own controls.<br>- Heat & DHW: The boiler is used for Space heating and DHW.<br>- Heating only: The boiler is used for Space heating only. The heat pump is heating the DHW year-round. | Not use/Heat & DHW/Heating only | -    | Not use   |
| CONFIGURATION | -        | -               | DHW boost heater          | If an electric boost heater is installed in the DHW tank, choose 'Installed'.   | -                               | -    | Installed |
|               | -        | -               | RMC master/slave          | If additional RMC is used to be placed inside Reference room, this setting must be changed to 'Slave'. The RMC that becomes 'Master' will show all setting options. The 'Slave' will show the complete User menu, but a limited Installer menu. Room air temp. measured by Slave will be used as reference for 'Air' and 'Air+Water' control.   | Master/Slave                    | -    | Master    |
|               | -        | -               | LG Therma V configuration | Read data 'will read configuration file from SD-Card. File name must be 'RS3_AWHP_DATA' in root directory!<br>'Save data' will save configuration file to SD-Card (e.g. for using at other site)  | Read Data/Save Data             | -    | -         |

| Top menu | Sub Menu | Collective menu       | Setting                     | Explanation  | Setting option | Unit | Default |
|----------|----------|-----------------------|-----------------------------|--|----------------|------|---------|
| GENERAL  |          |                       | Forced pump operation       | If function is activated, the internal pump will run at set interval to prevent stinking of pump when unit is out of operation for long time.                    | Use/Not Use    | -    | Use     |
|          | -        | Forced pump operation | Oper. Cycle                 | Interval of "anti-stuck function"  | 20...180       | min  | 20      |
|          |          |                       | Oper. Time                  | Running time of "anti-stuck function"  | 1...10         | min  | 10      |
|          |          |                       | Pump prerun                 | Time how long pump will operate, before compressor starts.   | 1...10         | min  | 1       |
|          |          | Pump prerun/overrun   | Pump overrun                | Time how long pump will operate, after compressor stopped.   | 1...10         | min  | 1       |
|          |          |                       | Backup heater release temp. | - Bivalent point: Below this outdoor air temperature, the backup heater is enabled.<br>- Remark: Even if the temp. is colder, it will only turn on if necessary! | -15...18       | °C   |         |

| Top menu | Sub Menu      | Collective menu | Setting          | Explanation  | Setting option      | Unit | Default |
|----------|---------------|-----------------|------------------|--|---------------------|------|---------|
| GENERAL  |               | -               | Activation       | Activation/Deactivation of screed-drying program. If activated, the leaving water target temp. will follow strict pattern acc. EN1264. Default: time of complete program is 30 days! | On/Off              | -    | Off     |
|          |               | -               | Step             | If program was interrupted, it can be re-started from any step (refer to manual for details)   | Step 1...11         | -    | Step 1  |
|          | Screed drying | -               | Max. temp.       | Max. target temp. while Screed drying is active. Match with specification of underfloor heating system.  | 35..50              | °C   | 50      |
|          |               | -               | Step & Holding   | Defines how long the max. temperature shall be kept.   | 1...30              | days | 7       |
|          |               | -               | Heating priority | Determination if room heating or sanitary hot water has higher priority to be heated.  | DHW / Space heating | -    | DHW     |
|          |               | -               | Password Reset   | Setting will reset the User password to '0000'.  | Reset               | -    | -       |
|          |               | -               |                  |  |                     |      |         |

| Top menu | Sub Menu       | Collective menu                | Setting  | Explanation  | Setting option                            | Unit | Default  |
|----------|----------------|--------------------------------|--|--|---|------|----------|
| CIRCUIT1 | Basic settings | Main pump operation            | Main pump operation  | Time setting = Main circulation pump is turned on and off according to set On/Off times.<br>Continuous operation = Main circulation pump is running continuously during heating (cooling) period. Only in summertime it is turned off. | Time operation setting/Continuous setting | min  | 5        |
|          |                |                                | On time  | Setting defines duration of Main pump operation to sense reference temp. from Circuit 1. Value should be adjusted based on length of pipework.   | 1...60                                    | min  | 15       |
|          |                | Off time                       | Setting defines interval between Main pump operations, while Thermo-off. Value should be adjusted based on building insulation standard. | -9.0...0.0<br>0.0...4.0  | K   | 2.0  |          |
|          |                | Hysteresis water temp (TH on)  | Settings define the hysteresis applied to water temp. control of Circuit 1   | 0.0...4.0  | K   | 2.0  |          |
|          |                | Hysteresis water temp (TH off) |  | -3.0...0.0   | K   | -0.5 |          |
|          | Room Heating   | Hysteresis room air            | Hysteresis room air (TH on)  | Settings define the hysteresis applied to room air temp. control of Circuit 1  | 0.0...4.0                                 | K    | 1.5      |
|          |                |                                | Hysteresis room air (TH off)   |  | 16...22                                   | °C   | 16       |
|          |                | Air setting range              | Air setting range (Min)  | Air setting range (Max)  | 24...30                                   | °C   | 30       |
|          |                | Water heating set temp.        | Water setting range (Min)  | Water setting range (Max)  | 15 ~ 34<br>35 ~ 50                        | °C   | 15<br>50 |
|          |                | Air cooling set temp.          | Air setting range (Min)  | Air setting range (Max)  | 16...22                                   | °C   | 16       |
|          | Room Cooling   | Water cooling set temp.        | Water setting range (Min)  | The User's setting range of room air target temperature in COOL mode can be limited  | 24...30                                   | °C   | 30       |
|          |                |                                | Water setting range (Max)  |  | 5...20                                    | °C   | 5        |
|          |                |                                |  | The User's setting range of water target temperature in COOL mode can be limited   | 22...27                                   | °C   | 27       |

| Top menu  | Sub Menu           | Collective menu      | Setting                   | Explanation   | Setting option   | Unit  | Default      |    |    |
|-----------|--------------------|----------------------|---------------------------|---|--|---|--------------|----|----|
| Auto Mode |                    | -                    | Mode                      | Definition if weather-dependency (Auto mode) is applied to heating and cooling or heating only. | Heating only / Heating & Cooling   | -   | Heating only |    |    |
|           |                    |                      | Outdoor 1, Heat           |   | -25 ~ 35   | °C  | -10          |    |    |
|           |                    |                      | Outdoor 2, Heat           |   | -25 ~ 35   | °C  | 18           |    |    |
|           |                    |                      | Outdoor 3, Cool           |   | 10 ~ 46  | °C  | 30           |    |    |
|           | Seasonal auto temp | Outdoor temperatures |                           | Outdoor 4, Cool   | Setting the outdoor temperature ranges for heating and cooling in Auto mode. | 10 ~ 46   | °C           | 40 |    |
|           |                    |                      |                           | Air 1, Heat (Circuit 1)   |  | 16 ~ 30   | °C           | 21 |    |
|           |                    |                      |                           | Air 2, Heat (Circuit 1)   |  | 16 ~ 30   | °C           | 19 |    |
|           |                    |                      |                           | Air 3, Cool (Circuit 1)   |  | 18 ~ 30   | °C           | 21 |    |
|           |                    |                      | Target temperatures       | Air 4, Cool (Circuit 1)   |  | Graphic setting of targets for Water / Indoor air temperature in Heating / Cooling operation for Circuit 1/2. | 18 ~ 30      | °C | 19 |
|           |                    |                      |                           | Water 1, Heat (Circuit 1)   |  |   | 15 ~ 50      | °C | 50 |
|           |                    |                      |                           | Water 2, Heat (Circuit 1)   |  |   | 15 ~ 50      | °C | 40 |
|           |                    |                      |                           | Water 3, Cool (Circuit 1)   |  |   | 5 ~ 27       | °C | 12 |
|           |                    |                      | Water 4, Cool (Circuit 1) |   | 5 ~ 27   | °C  | 10           |    |    |

| Top menu  | Sub Menu           | Collective menu     | Setting                      | Explanation   | Setting option | Unit | Default |
|-----------|--------------------|---------------------|------------------------------|---|----------------|------|---------|
| Auto Mode | Seasonal auto temp | Target temperatures | Air 1,<br>Heat (Circuit 2)   | Graphic setting of targets for Water / Indoor air temperature in Heating / Cooling operation for Circuit 1/2. | 16...30        | °C   | 21      |
|           |                    |                     | Air 2,<br>Heat (Circuit 2)   |   | 16...30        | °C   | 19      |
|           |                    |                     | Air 3,<br>Cool (Circuit 2)   |   | 18...30        | °C   | 21      |
|           |                    |                     | Air 4,<br>Cool (Circuit 2)   |   | 18...30        | °C   | 19      |
|           |                    |                     | Water 1,<br>Heat (Circuit 2) |   | 15 ~ 50        | °C   | 50      |
|           |                    |                     | Water 2,<br>Heat (Circuit 2) |   | 15 ~ 50        | °C   | 40      |
|           |                    |                     | Water 3,<br>Cool (Circuit 2) |   | 5 ~ 27         | °C   | 12      |
|           |                    |                     | Water 4,<br>Cool (Circuit 2) |   | 5 ~ 27         | °C   | 10      |

| Top menu             | Sub Menu               | Collective menu     | Setting                     | Explanation   | Setting option  | Unit  | Unit        |       |         |
|----------------------|------------------------|---------------------|-----------------------------|---|---|---|-------------|-------|---------|
| Domestic Hot Water   | DHW temp. settings     | DHW set temp. range | DHW set temp. range (Min)   | Limitation of setting range (DHW temp. target that User can set)  | 30-60   | °C  | 30          |       |         |
|                      |                        | -                   | DHW set temp. range (Max)   |   | 50...80   | °C  | 50          |       |         |
|                      |                        | -                   | Compressor cycle limit temp | This is the max. DHW temp. that can be reached by using compressor cycle only (without using electrical heater). It also depends on effectiveness of heat transfer from heat pump to DHW tank (size of coil, sensor positioning). | 40...50   | °C  | 50          |       |         |
|                      | Thermal disinfection 1 | -                   | -                           | DHW hysteresis  | Temperature gap between DHW target temp. (by User) and DHW temperature when re-heating starts.<br>Example: Target temp. = 48°C DHW hysteresis = 5 K<br>→ DHW heating starts at 43°C | 1...30  | K           | 5     |         |
|                      |                        |                     |                             | -   | Disinfection active   | Activation/Deactivation of anti-legionella operation. Electric heater must be connected and activated to perform this function. | Not use/Use | -     | Not use |
|                      |                        | -                   | -                           | Weekday   | Weekday and time at which the anti-legionella function is executed.   | Sun/Mon./Tue./Wed./Thu./Fri./Sat.   | -           | -     | Fri     |
|                      |                        |                     |                             | Start time  |   | 0-23  | hh:--       | 23:00 |         |
|                      | Thermal disinfection 2 | -                   | -                           | Max. Temp.  | Target temp. for thermal disinfection cycle.  | 60...80   | °C          | 70    |         |
|                      |                        |                     |                             | Duration  | Duration how long disinfection target temp. is kept. After time has elapsed, target is reduced to normal setpoint.  | 5-60  | min         | 10    |         |
|                      |                        | -                   | -                           | Forced end time   | After this time has elapsed, thermal disinfection will stop - even if disinfection temp. is not reached.  | 1-12  | hrs         | 1     |         |
| DHW heating duration | -                      | -                   | Active time                 | Duration how long DHW heating continues   | 5...95  | min   | 30          |       |         |
|                      |                        |                     | Stop time                   | Duration how long DHW heating is interrupted (if DHW target is not reached in one cycle)  | 0...600   | min   | 30          |       |         |

| Top menu             | Sub Menu                        | Collective menu | Setting               | Explanation   | Setting option                                | Unit | Default          |
|----------------------|---------------------------------|-----------------|-----------------------|---|---|------|------------------|
| DOMESTIC HOT WATER   | DHW electric re-heating         | -               | DHW heater usage      | <p><b>- Use:</b> DHW will be re-heated electrically if the heat pump cycle does not reach the target temp. within time setting.</p> <p><b>- Use disinfection:</b> Electric re-heating is only used for anti-legionella operation and in case of emergency.</p> <p><b>- Use emergency:</b> Electrical heater is only used in case of emergency.</p> <p>If settings 'Use disinfect' or 'Use emergency' is chosen, the DHW temp. setting range is limited!</p> | Use always / Use disinfection / Use emergency | -    | Use disinfection |
|                      |                                 |                 | DHW heater delay time | After time has elapsed, the DHW boost heater is released.   | 10 / 20 / 30 / 40 / 50 / 60 / 90 / 120 / 1440 | min  | 30               |
|                      |                                 |                 | Enable re-circulation | Definition if DHW recirculation pump is connected or not. If it is used, a Schedule in the main menu becomes available to set the time frames for operating the pump.   | Use / Not use                                 | -    | Not use          |
| SOLAR THERMAL SYSTEM | DHW re-circulation              | -               | On                    | Definition of recirculation pump cycling pattern during release schedule. By default, the pump operates every twenty minutes for 10 minutes (only during the set Schedule!)   | 5 ~ 60  | min  | 10               |
|                      |                                 |                 | Off                   |   | 5 ~ 60  | min  | 20               |
|                      | Solar collector operating range | -               | Min.                  | Solar cycle will not start before collector has reached this temp.  | 5 ~ 50  | °C   | 10               |
|                      |                                 |                 | Max.                  | Solar cycle will not start if collector exceeds this temp.  | 60 ~ 200                                      | °C   | 135              |
|                      | Solar tank temp. Limit          | -               | Max.                  | Solar cycle will not start, if DHW tank has reached its maximum temp.   | 20 ~ 80                                       | °C   | 80               |

| Top menu             | Sub Menu               | Collective menu         | Setting                   | Explanation   | Setting option   | Unit     | Default |       |
|----------------------|------------------------|-------------------------|---------------------------|---|--|----------|---------|-------|
| SOLAR THERMAL SYSTEM | -                      | Solarthermal $\Delta T$ | Temp On                   | Delta temp. between Solar collector and DHW tank must be reached before solar pump starts.<br><b>Example:</b><br>Actual DHW/ temp. = 45 °C, Temp On = 8 K<br>→ Solar cycle start, if collector exceeds 53 °C  | 3 ~ 40   | K        | 8       |       |
|                      |                        |                         | Temp Off                  | Delta temp. between Solar collector and DHW tank must be undercut before solar cycle stops.<br><b>Example:</b><br>Actual DHW/ temp. = 45°C, Temp Off = 2K<br>→ Solar cycle stops, if collector undercuts 47°C   | 1 ~ 20   | K        | 2       |       |
|                      | -                      | -                       | Renewable DHW heating     | The electrical DHW boost heater can be disabled, while solar cycle is in operation.   | Enable / Disable   | -        | Enable  |       |
|                      | -                      | -                       | Solar pump flush schedule | Frequent activation of solar pump can be activated/deactivated. This function is recommended only if there are random shadows (tree, chimney,...) covering the collector sensor. If solar cycle is out of operation, solar pump will start after this time has elapsed, in order to check the available solar temp. Duration should be as long as necessary, but as short as possible. If collector is cold, heat will be wasted "to the roof!" | On / Off   | -        | Off     |       |
|                      | Solar circuit flushing | -                       | -                         | Start Hour  | Within this time frame the Solar flushing function is enabled. Flushing is only reasonable during daytime.<br><br>Duration how long the solar pump operates to flush the circuit | 0 ~ 23   | hh:--   | 6:00  |
|                      |                        | -                       | -                         | Start Minute  |  | 0 ~ 59   | --:mm   |       |
|                      |                        | -                       | -                         | End Hour  |  | 0 ~ 23   | hh:--   | 18:00 |
|                      |                        | -                       | -                         | End Minute  |  | 0 ~ 59   | --:mm   |       |
|                      | -                      | -                       | -                         | Oper. Time  | Duration how long the solar pump operates to flush the circuit   | 1 ~ 10   | -       | 1     |
|                      | -                      | -                       | Solar pump flush setting  | Oper. Cycle   | Duration until next flushing starts  | 30 ~ 120 | -       | 60    |
| -                    | -                      | -                       | Solar pump test run       | 'Start' will activate the solar pump for 1 hour. During this period, the pump will be turned on and off intermittently to purge air from the cycle.   | Start / Stop   | -        | -       |       |

| Top menu                 | Sub Menu      | Collective menu | Setting                        | Explanation   | Setting option  | Unit        | Default      |   |   |   |   |   |
|--------------------------|---------------|-----------------|--------------------------------|---|---|-------------|--------------|---|---|---|---|---|
| Service                  | -             | -               | Pump test run                  | The pump test run is to test run by operating the water pump for 1 hour.                                | Test Run  | -           | -            |   |   |   |   |   |
|                          |               |                 | A1<br>Main pump                |   |   |             |              |   |   |   |   |   |
|                          | Actuator test | Pump test       | A2<br>External pump            |   | In this Service menu, the actuators like pumps and valves can be activated to check for correct operation during commissioning. | On / Off    | -            | - |   |   |   |   |
|                          |               |                 | A3<br>Mix pump                 |   |   |             |              |   |   |   |   |   |
|                          |               |                 | A4<br>Solar pump               |   |   |             |              |   |   |   |   |   |
|                          |               |                 | A15<br>DHW Re-circulation pump |   |   |             |              |   |   |   |   |   |
|                          |               |                 | A5<br>DHW 3-way-valve          |   |   |             |              |   |   |   |   |   |
|                          |               |                 | A6/7<br>Mixing valve           |   |   |             |              |   |   |   |   |   |
|                          | Valve test    | -               | A12<br>Cooling 2-way-valve     |   |   | DHW / Space | Open / Close | - | - |   |   |   |
|                          |               |                 | S9<br>Refrigerant gas          |   |   |             |              |   |   |   |   |   |
|                          |               |                 | S10<br>Refrigerant liquid      |   |   |             |              |   |   |   |   |   |
|                          |               |                 | S11<br>Entering water          |   |   |             |              |   |   |   |   |   |
|                          |               |                 | S12<br>Leaving water           |   |   |             |              |   |   |   |   |   |
|                          | Monitoring    | Sensor value    | S13<br>Backup heater outlet    | In this Service menu, all sensor values are displayed to easily recognize if all values are reasonable. | -   | °C          | -            |   |   |   |   |   |
|                          |               |                 | S14<br>DHW tank                |   |   |             |              |   |   |   |   |   |
|                          |               |                 | S15<br>Solar collector         |   |   |             |              |   |   |   |   |   |
|                          |               |                 | S16<br>Solar tank              |   |   |             |              |   |   |   |   |   |
| S17<br>Water flow sensor |               |                 |                                |   |   |             |              |   |   |   |   |   |
| -                        |               |                 | -                              |   |   |             |              | - | - | - | - | - |

| Top menu                     | Sub Menu   | Collective menu | Setting                          | Explanation   | Setting option | Unit | Default |
|------------------------------|------------|-----------------|----------------------------------|---|----------------|------|---------|
| Service                      |            | Sensor value    | S18<br>Mixing circuit            | In this Service menu, all sensor values are displayed to easily recognize if all values are reasonable. | -              | °C   | -       |
|                              |            |                 | S19<br>Water pressure            |   | -              | °C   | -       |
|                              |            |                 | S21<br>Room temp. Direct circuit |   | -              | °C   | -       |
|                              |            |                 | S22<br>Room temp. Mixing circuit |   | -              | °C   | -       |
|                              |            | SG1             | 0 / 1                            |   | -              | -    |         |
|                              |            | SG2             | 0 / 1                            |   | -              | -    |         |
|                              |            | CN-EXT          | 0 / 1                            |   | -              | -    |         |
|                              | Monitoring | Input status    | Antifreeze shortkey              | In this Service menu, the status of all physical inputs are listed up                                   | 0 / 1          | -    | -       |
|                              |            |                 | Thermostat (Heating)             |   | 0 / 1          | -    | -       |
|                              |            |                 | Thermostat (Cooling)             |   | 0 / 1          | -    | -       |
|                              |            |                 | Thermostat (DHW)                 |   | 0 / 1          | -    | -       |
|                              |            |                 | A1<br>Main pump                  |   | 0 / 1          | -    | -       |
|                              |            |                 | A2<br>External pump              |   | 0 / 1          | -    | -       |
|                              |            | Output status   | A3<br>Mix pump                   | In this Service menu, the status of all physical outputs are listed up                                  | 0 / 1          | -    | -       |
|                              |            |                 | A4<br>Solar pump                 |   | 0 / 1          | -    | -       |
|                              |            |                 | A5<br>DHW 3-way-valve            |   | DHW / Space    | -    | -       |
|                              |            |                 | A6<br>Mixing valve (Open)        |   | 0 / 1          | -    | -       |
| A7<br>Mixing valve (Close)   |            |                 | 0 / 1                            |   | -              | -    |         |
| A8<br>Backup heater (Step 1) |            |                 | 0 / 1                            |   | -              | -    |         |

| Top menu | Sub Menu       | Collective menu | Setting                       | Explanation  | Setting option                       | Unit  | Default |   |   |
|----------|----------------|-----------------|-------------------------------|--|--------------------------------------|---|---------|---|---|
| Service  | Monitoring     |                 | A9<br>Backup heater (Step 2)  | In this Service menu, the status of all physical outputs are listed up | 0 / 1                                | -   | -       |   |   |
|          |                |                 | A10<br>DHW Boost heater       |  | 0 / 1                                | -   | -       |   |   |
|          |                |                 | A11<br>External boiler        |  | 0 / 1                                | -   | -       |   |   |
|          |                |                 | A12<br>Cooling 2-way-valve    |  | 0 / 1                                | -   | -       |   |   |
|          |                |                 | A15<br>DHW Recirculation pump |  | 0 / 1                                | -   | -       |   |   |
|          |                | Runtimes        |                               | -  | Backup heater (Step 1)               | The total runtimes are of main components re displayed.<br>The information can be used to identify cause of excessive energy consumption or abnormal cycling of compressor. | -       | h | - |
|          |                |                 |                               | -  | Backup heater (Step 2)               |   | -       | h | - |
|          |                |                 |                               | -  | Boost heater                         |   | -       | h | - |
|          |                |                 |                               | -  | Main pump                            |   | -       | h | - |
|          |                |                 |                               | -  | Solar pump                           |   | -       | h | - |
|          | Runtimes reset |                 | -                             | Backup heater Reset  | In this menu, runtimes can be reset. | Reset   | -       | - |   |
|          |                |                 | -                             | Boost Heater Reset   |                                      | Reset   | -       | - |   |
|          |                |                 | -                             | Pump operation time  |                                      | Reset   | -       | - |   |
|          |                |                 | -                             | Solar pump Reset   |                                      | Reset   | -       | - |   |
|          |                |                 | -                             |  |                                      | Reset   | -       | - |   |

| Top menu     | Sub Menu    | Collective menu  | Setting                      | Explanation  | Setting option   | Unit    | Default          |
|--------------|-------------|------------------|------------------------------|--|--|---------|------------------|
| Connectivity | Dry contact | -                | Dry Contact Mode             | - Manual: Unit must be turned-on by RMC after release by Dry contact<br>- Auto: Unit will automatically start (return to previous operation) after release by D/C  | Auto/Manual  | -       | Auto             |
|              |             | -                | CN_CC                        | - Auto: Unit will recognize connected D/C after power-on<br>Not installed: D/C is not installed<br>- Installed: D/C is installed and unit always checks its state<br>Additionally, check setting for 'Dry contact mode'!   | D/C Automatic /<br>D/C Not Installed /<br>D/C Installed  | -       | D/C<br>Automatic |
|              | -           | -                | Central control address(HEX) | Address setting if LG Central controller is connected  | 0~F/0~F  | hexdec. | 00               |
|              | -           | -                | CN_EXT                       | - Not use: CN_EXT is not used<br>- Simple operation: open= Operation off closed= Operation On<br>- Simple dry contact: open= unit locked closed= lock released, operation on/off depends on setting 'Dry contact mode'<br>- Single emergency stop: open= unit locked closed= lock released | Not use/<br>Simple Operation/<br>Simple dry contact /<br>Single emergency stop /<br>All emergency stop | -       | Not use          |
|              | -           | -                | Mode                         | Boiler can be activated either manually (by User setting) or automatically (below certain outdoor temp.)   | Auto/Manual  | -       | Manual           |
|              | -           | -                | Temp.                        | Boiler will be activated, if outdoor temp. undercuts this value. Heat pump will stop.  | -25...25   | °C      | -7               |
|              | -           | 3rd party boiler | Hysteresis                   | Boiler will be de-activated and heat pump re-activated, if outdoor temp. exceeds temp. setting plus hysteresis.<br>Example: Temp. = -7°C, Hysteresis = 4K<br>→ Boiler is enabled at -7°C and disabled at -3°C outdoor temp.  | 2...10   | K       | 4                |

| Top menu     | Sub Menu     | Collective menu         | Setting         | Explanation   | Setting option             | Unit | Default |
|--------------|--------------|-------------------------|-----------------|---|----------------------------|------|---------|
| Connectivity | Energy state | Energy state definition | Signal type     | External devices such as Home Energy Management Systems can be used to influence the operation of the heat pump.<br>Either two 230V inputs are used to collect the status or Modbus isn used (for instance when connected to LG ESS). | Not use/230V inputs/Modbus | -    | Not use |
|              |              |                         | Energy state 5  | Setting whether Energy state 5 is used or not.  | Not use/Use                |      |         |
|              |              |                         | ES5: Heat temp. | Definition how much Heating target temp. shall increase when ES5 is applied.  | 0...30                     | K    | 5       |
|              |              |                         | ES5: Cool temp. | Definition how much Cooling target temp. shall decrease when ES5 is applied.  | 0...-30                    | K    | -5      |
|              |              |                         | ES5: DHW temp.  | Definition how much DHW target temp. shall increase when ES5 is applied.  | 0...50                     | K    | 30      |
|              |              |                         | Energy state 6  | Setting whether Energy state 6 is used or not.  | Not use/Use                |      |         |
|              |              |                         | ES6: Heat temp. | Definition how much Heating target temp. shall increase when ES6 is applied.  | 0...30                     | K    | 2       |
|              |              |                         | ES6: Cool temp. | Definition how much Cooling target temp. shall decrease when ES6 is applied.  | 0...-30                    | K    | -2      |
|              |              |                         | ES6: DHW temp.  | Definition how much DHW target temp. shall increase when ES6 is applied.  | 0...50                     | K    | 10      |

| Top menu     | Sub Menu                  | Collective menu         | Setting         | Explanation  | Setting option         | Unit | Default |             |
|--------------|---------------------------|-------------------------|-----------------|--|------------------------|------|---------|-------------|
| Connectivity | Energy state              | Energy state definition | Energy state 7  | Setting whether Energy state 7 is used or not.   | Not use/Use            |      |         |             |
|              |                           |                         | ES7: Heat temp. | Definition how much Heating target temp. shall increase when ES7 is applied.   | 0...-30                | K    | -2      |             |
|              |                           |                         | ES7: Cool temp. | Definition how much Cooling target temp. shall decrease when ES7 is applied.   | 0...30                 | K    | 2       |             |
|              |                           |                         | ES7: DHW temp.  | Definition how much DHW target temp. shall increase when ES7 is applied.   | 0...-50                | K    | 0       |             |
|              |                           |                         | Energy state 8  | Setting whether Energy state 8 is used or not.   | Not use/Use            |      |         |             |
|              |                           |                         | ES8: Heat temp. | Definition how much Heating target temp. shall increase when ES8 is applied.   | 0...-30                | K    | -5      |             |
|              |                           |                         | ES8: Cool temp. | Definition how much Cooling target temp. shall decrease when ES8 is applied.   | 0...30                 | K    | 5       |             |
|              |                           |                         | ES8: DHW temp.  | Definition how much DHW target temp. shall increase when ES8 is applied.   | 0...-50                | K    | 0       |             |
|              | Digital inputs assignment | State 3 (0:1)           | State 3 (0:1)   | Definition of Energy state 3:<br>-3 = Cooling/no effect, Heating/Target +2K, DHW/Target +5K<br>-4 = Cooling/no effect, Heating/no effect, DHW/Target=80°C<br>-5--8 = according setting "Energy state definition" | 3...8                  | -    | 3       |             |
|              |                           |                         |                 | Definition of Energy state 4:<br>-3 = Cooling/no effect, Heating/Target +2K, DHW/Target +5K<br>-4 = Cooling/no effect, Heating/no effect, DHW/Target=80°C<br>-5--8 = according setting "Energy state definition" | 3...8                  | -    | 4       |             |
|              |                           |                         |                 | Setting what type of thermostat is connected   | Heat & Cool / DHW only |      |         | Heat & Cool |
|              |                           |                         |                 | Thermostat control type  |                        |      |         |             |

# COMMISSIONING

If everything is going well until now, it is time to start the operation and to take advantages of **Hydro Kit**.

Before starting operation, pre-check points are described in this chapter. Some comments about maintenance and how to do troubleshooting are presented.

## Check List before Starting Operation



### CAUTION

Turn off the power before changing wiring or handling product.

| No | Category             | Item                   | Check Point   |
|----|----------------------|------------------------|---|
| 1  | Electricity          | Field wiring           | <ul style="list-style-type: none"> <li>• All switches having contacts for different poles should be wired tightly according to regional or national legislation.</li> <li>• Only qualified person can proceed wiring.</li> <li>• Wiring and local-supplied electric parts should be complied with European and regional regulations.</li> <li>• Wiring should be following the wiring diagram supplied with the product.</li> </ul> |
| 2  |                      | Protective devices     | <ul style="list-style-type: none"> <li>• Install ELB (earth leakage breaker) with 30 mA.</li> <li>• ELB inside the control box of the unit should be turned on before starting operation.</li> </ul>  |
| 3  |                      | Earth wiring           | <ul style="list-style-type: none"> <li>• Earth should be connected. Do not earth to gas or city water pipe, metallic section of a building, surge absorber, etc.</li> </ul>   |
| 4  |                      | Power supply           | <ul style="list-style-type: none"> <li>• Use dedicated power line.</li> </ul>   |
| 5  |                      | Terminal block wiring  | <ul style="list-style-type: none"> <li>• Connections on the terminal block (inside the control box of the unit) should be tightened.</li> </ul>   |
| 6  | Water                | Charged water pressure | <ul style="list-style-type: none"> <li>• After water charging, the pressure gauge (in front of the unit) should indicate 2.0~2.5 bar. Do not exceed 3.0 bar.</li> </ul>   |
| 7  |                      | Air purge              | <ul style="list-style-type: none"> <li>• During water charging, air should be taken out through the hole of the air purge.</li> <li>• If water does not splash out when the tip (at the top of the hole) is pressed, then air purging is not completed yet. If well purged, the water will splash out like fountain.</li> <li>• Be careful when testing air purge. Splashed water may make your dress wet.</li> </ul>               |
| 8  |                      | Shut-off valve         | <ul style="list-style-type: none"> <li>• Two shut-off valves (located at the end of water inlet pipe and water outlet pipe of the unit) should be open.</li> </ul>  |
| 9  |                      | By-pass valve          | <ul style="list-style-type: none"> <li>• By-pass valve should be installed and adjusted to secure enough water flow rate. If water flow rate is low, flow switch error (CH14) can be occurred.</li> </ul>   |
| 10 | Product Installation | Hang to the wall       | <ul style="list-style-type: none"> <li>• As the unit is hung on the wall, vibration or noise can be heard if the unit is not fixed tightly.</li> <li>• If the unit is not fixed tightly, it can fall down during operation.</li> </ul>  |
| 11 |                      | Parts inspection       | <ul style="list-style-type: none"> <li>• There should be no apparently damaged parts inside the unit.</li> </ul>  |
| 12 |                      | Refrigerant leakage    | <ul style="list-style-type: none"> <li>• Refrigerant leakage degrades the performance. If leakage found, contact qualified LG air conditioning installation person.</li> </ul>  |
| 13 |                      | Drainage treatment     | <ul style="list-style-type: none"> <li>• While cooling operation, condensed dew can drop down to the bottom of the unit. In this case, prepare drainage treatment (for example, vessel to contain condensed dew) to avoid water drop.</li> </ul>  |

To assure best performance of **Hydro Kit**, it is required to perform periodical check and maintenance. It is recommended to proceed following check list for once a year.



## CAUTION

Turn off the power before proceeding maintenance.

| No | Category    | Item                    | Check Point   |
|----|-------------|-------------------------|---|
| 1  | Water       | Water pressure          | <ul style="list-style-type: none"> <li>• In normal state, the pressure gauge (in front of the unit) should indicate 2.0~2.5 bar.</li> <li>• If the pressure is less than 0.3 bar, please recharge the water.</li> </ul>       |
| 2  |             | Strainer (Water filter) | <ul style="list-style-type: none"> <li>• Close the shut-off valves and disassemble strainer. Then wash the strainer to make it clean.</li> <li>• While disassembling the strainer, be careful for water flood out.</li> </ul> |
| 3  |             | Safety valve            | <ul style="list-style-type: none"> <li>• Open the switch of the safety valve and check if water is flood out through the drain hose.</li> <li>• After checking, close the safety valve.</li> </ul>                            |
| 4  | Electricity | Terminal block wiring   | <ul style="list-style-type: none"> <li>• Look and inspect if there is loosen or defected connection on the terminal block.</li> </ul>   |

## Starting Operation

### Check before Starting Operation

|   |   |
|---|---|
| 1 | Check to see whether there is any refrigerant leakage, and check whether the power or transmission cable is connected properly.   |
| 2 | <p>Confirm that 500 V megger shows 2.0 M<math>\Omega</math> or more between power supply terminal block and ground. Do not operate in the case of 2.0 M<math>\Omega</math> or less.</p> <p><b>NOTE:</b><br/>Never carry out mega ohm check over terminal control board.<br/>Otherwise the control board may break.</p> <p>Immediately after mounting the unit or after leaving it turned off for an extended length of time, the resistance of the insulation between the power supply terminal board and the ground may decrease to approx. 2.0 M<math>\Omega</math> as a result of refrigerant accumulation in the internal compressor.</p> <p>If the insulation resistance is less than 2.0 M<math>\Omega</math>, turn on the main power supply.</p> |
| 3 | When the power is applied for the first time, operate the product after preheating for 2 hours. To protect the unit by increasing the oil temperature of the compressor.  |

## Starting Operation flow chart

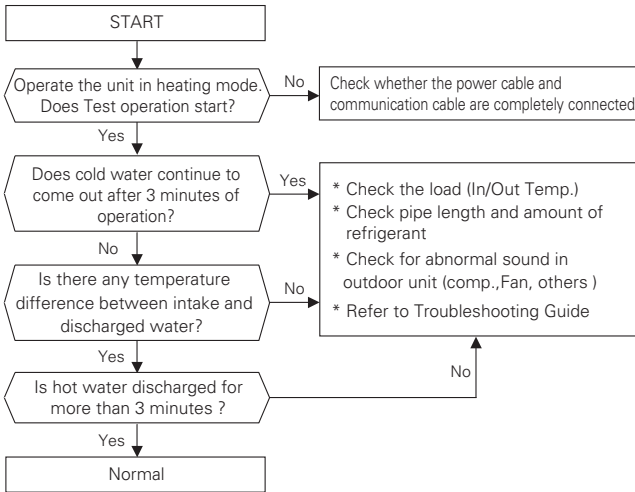

## Airborne Noise Emission

The A-weighted sound pressure emitted by this product is below 70 dB.

\*\* The noise level can vary depending on the site.

The figures quoted are emission level and are not necessarily safe working levels.

Whilst there is a correlation between the emission and exposure levels, this cannot be used reliably to determine whether or not further precautions are required.

Factor that influence the actual level of exposure of the workforce include the characteristics of the work room and the other sources of noise, i.e. the number of equipment and other adjacent processes and the length of time for which an operator exposed to the noise.

Also, the permissible exposure level can vary from country to country.

This information, however, will enable the user of the equipment to make a better evaluation of the hazard and risk.

## Decommissioning and Recycling

- Sort the packaging according to cardboard, wood and foil and dispose of it in appropriate containers.
- After the lifespan of the device ends it has to be disposed of in accordance with the legislation on waste electrical and electronic devices in force.

### Extraction of Refrigerant

The indoor unit has to be connected to the outdoor unit holding the HFC refrigerant R32 which is a fluorinated greenhouse gas covered in the Kyoto protocol. You have to prevent leakage of the gas into the atmosphere. During a maintenance procedure or removal of the device, make sure that the gas is removed in accordance with the current regulations for the use of substances harmful to the ozone and fluorinated greenhouse gases.

## Troubleshooting

If **Hydro Kit** operates not properly or it does not start operation, please check following list.



### CAUTION

Turn off the power before proceeding troubleshooting.

### Troubleshooting for Problem while Operation

| No | Problem   | Reason   | Solution  |
|----|---|--|---|
| 1  | Heating or Cooling is not satisfactory.   | <ul style="list-style-type: none"> <li>Setting target temperature is not proper.</li> </ul>            | <ul style="list-style-type: none"> <li>Set target temperature correctly.</li> <li>Check if temperature is water-based or air-based. See 'Remote sensor active' and 'Temp. sensor selection' in Chapter6.</li> </ul>   |
|    |   | <ul style="list-style-type: none"> <li>Charged water is not enough.</li> </ul>                         | <ul style="list-style-type: none"> <li>Check pressure gage and charge more water until pressure gage is indication 2~2.5 Bar</li> </ul>   |
|    |   | <ul style="list-style-type: none"> <li>Water flow rate is low.</li> </ul>                              | <ul style="list-style-type: none"> <li>Check if strainer gathers too much particles. If so, strainer should be cleaned.</li> <li>Check if pressure gauge indicates above 4 Bar</li> <li>Check if water pipe is getting closed due to stacked particles or lime.</li> </ul>  |
| 2  | Although electric power supply is OK (remote controller displays information), the unit does not start working. | <ul style="list-style-type: none"> <li>Water inlet temperature is too high.</li> </ul>                 | <ul style="list-style-type: none"> <li>If water inlet temperature is above 57 °C, the unit does not operated for the sake of system protection</li> </ul>   |
|    |   | <ul style="list-style-type: none"> <li>Water inlet temperature is too low.</li> </ul>                  | <ul style="list-style-type: none"> <li>If water inlet temperature is below 5 °C in cooling operation, the unit does not operated for the sake of system protection. Wait while unit warms up the water inlet temperature.</li> <li>If water inlet temperature is below 15 °C in heating operation, the unit does not operated for the sake of system protection. Wait while unit warms up to 18 °C the water inlet temperature.</li> <li>If you are not using the back up heater accessory (HA**1M E1), increase the water temperature with the external heat source (heater, boiler).<br/>If the problem persists, contact your dealer.</li> <li>If you want to use the screed drying function, be sure to purchase and install back up heater accessories (HA**1M E1).</li> </ul> |
| 3  | Water pump noise.   | <ul style="list-style-type: none"> <li>Air purging is not completely finished.</li> </ul>              | <ul style="list-style-type: none"> <li>Open the cap of air purge and charge more water until pressure gage is indicating 2~2.5 Bar</li> <li>If water does not splash out when the tip(at the top of the hole) is pressed, then air purging is not completed yet. If well purged, the water will splash out like fountain.</li> </ul>  |
|    |   | <ul style="list-style-type: none"> <li>Water pressure is low.</li> </ul>                               | <ul style="list-style-type: none"> <li>Check if pressure gage indicates above 0.3 Bar.</li> <li>Check if the expansion tank and pressure gage operates well.</li> </ul>   |
| 4  | Water is flood out through drain hose.  | <ul style="list-style-type: none"> <li>Too much water is charged.</li> </ul>                           | <ul style="list-style-type: none"> <li>Flood out water by opening the switch of the safety valve until pressure gage is indicating 2~2.5 Bar.</li> </ul>  |
|    |   | <ul style="list-style-type: none"> <li>Expansion tank is damaged.</li> </ul>                           | <ul style="list-style-type: none"> <li>Replace the expansion tank</li> </ul>  |
| 5  | DHW is not hot.   | <ul style="list-style-type: none"> <li>Thermal protector of water tank heater is activated.</li> </ul> | <ul style="list-style-type: none"> <li>Open the side panel of the DHW tank and push the reset button of the thermal protector. (for more detail information, please refer to installation manual of DHW tank.</li> </ul>  |
|    |   | <ul style="list-style-type: none"> <li>DHW Heating is disabled.</li> </ul>                             | <ul style="list-style-type: none"> <li>Select DHW Heating Operation and identify if icon is displayed on the remote controller.</li> </ul>  |

## Troubleshooting for Error Code

| Error Code | Description  | Main Reasons  |
|------------|--|---|
| 01*        | Problem in Remote Room Air sensor                        | Remote air temperature sensor of MainPCB(indoor) is open or short.                      |
| 02**       | Problem in Refrigerant (Inlet side) sensor               | Refrigerant inlet pipe temperature sensor of indoor unit is open or short               |
| 03****     | Communication error between indoor unit and wired remote | Communication between wired remote controller and indoor unit is not possible.          |
| 05**       | Communication error between Main PCB(Indoor) and Main    | There is no communication between the Main PCB(Indoor) and the Main PCB(Outdoor cycle). |
| 06**       | Problem in Refrigerant pipe sensor (Outlet side)         | Refrigerant outlet pipe temperature sensor of indoor unit is open or short.             |
| 08***      | Problem in Water Tank sensor                             | Domestic hot water tank temperature sensor of indoor unit is open or short.             |
| 09****     | PCB Program (EEPROM) Fault                               | The optional EEPROM is loosely inserted in or disconnected from the Main PCB(Indoor)    |
| 13***      | Problem in Solar-thermal sensor                          | Solar pipe temperature sensor of indoor unit is open or short.                          |
| 14****     | Problem in Flow rate                                     | Low flow detection during pump operation  |
| 15****     | Overheating of water pipe                                | The temperature of the water pipe has exceeded a certain temperature.                   |
| 16****     | Problems in sensors                                      | An error code 17,18,19 error has occurred at the same time                              |
| 17*        | Problem in Water-inlet sensor                            | Water inlet pipe temperature sensor of indoor unit is open or short.                    |
| 18*        | Problem in Water-inlet sensor                            | Water outlet pipe temperature sensor of indoor unit is open or short.                   |
| 19*        | Problem in Elec/Heater Wateroutlet sensor                | Electric backup heater outlet temperature sensor of indoor unit is open or short.       |
| 231*       | Problem in Water Pressure                                | Water Pressure Sensor of indoor unit is   |
| 232****    | Problem in Flow Sensor                                   | Flow Sensor of indoor unit is damaged.  |

**Notice of error code****- Slight Trouble(S-Trouble) : \***

A trouble is occurred with temperature sensor of indoor unit. (sensing fail)  
Emergency operation(heating) is possible with heat pump and electric heater.

**- Heavy Trouble(H-Trouble) : \*\***

A trouble is occurred with cycle and system can not be operated  
Emergency operation(heating) is possible with electric heater ONLY.

**- Other Trouble(O-Trouble) : \*\*\***

A trouble is occurred with optional function. (e.g. DHW tank sensor, Solar thermal sensor)  
Emergency operation(heating) is possible with heat pump and electric heater.  
In case of CH13, Heat pump operation does not stop.

**- Error : \*\*\*\***

A serious fail was found and system can not be used before repair it.

**CAUTION****Precaution in service or check.**

Even after stopping the operation of product, it takes some time to discharge the remaining electricity of the electrolytic capacitor that was charged early. Before conducting a checking or repairing job, pull out the plug out of the outlet and make sure that the lamp on the control board outdoor unit is off.

## Model Designation

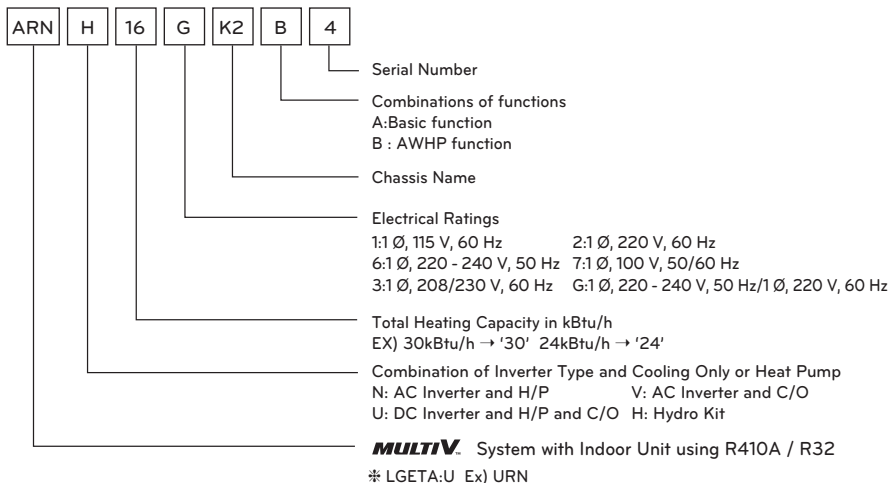

## Open Source Software Notice Information

To obtain the source code under GPL, LGPL, MPL, and other open source code licenses, that is contained in this product, Please visit <https://opensource.lge.com>.

In addition to the source code, all referred license terms, warranty disclaimers and copyright notice are available for download. LG Electronics will also provide open source code to you on CD-ROM for a charge covering the cost of performing such distribution (such as the cost of media, shipping, and handling) upon email request to [opensource@lge.com](mailto:opensource@lge.com). This offer is valid for three(3) years from the date on which you purchased the product.





Manufacturer :

LG Electronics Inc.

84, Wanam-ro, Seongsan-gu, Changwon-si, Gyeongsangnam-do, KOREA

UK Importer : LG Electronics U.K. Ltd

Velocity 2, Brooklands Drive, Weybridge, KT13 0SL

**Eco design requirement**

- The information for Eco design is available on the following free access website.

<https://www.lg.com/global/support/cedoc/cedoc>