

INSTALLATION MANUAL

AIR CONDITIONER

Please read this installation manual completely before installing the product.
Installation work must be performed in accordance with the national wiring standards by authorized personnel only.
Please retain this installation manual for future reference after reading it thoroughly.

Vertical Air Handling Unit



MFL67206513
Rev.04_092723

www.lghvac.com

www.lg.com

Copyright © 2016 - 2023 LG Electronics Inc. All Rights Reserved.

IMPORTANT!

Please read this instruction sheet completely before installing the product.

This air conditioning system meets strict safety and operating standards. As the installer or service person, it is an important part of your job to install or service the system so it operates safely and efficiently.

⚠ WARNING

- Installation or repairs made by unqualified persons can result in hazards to you and others. Installation of all field wiring and components MUST conform with local building codes or, in the absence of local codes, with the National Electrical Code 70 and the National Building Construction and Safety Code or Canadian Electrical code and National Building Code of Canada.
- The information contained in the manual is intended for use by a qualified service technician familiar with safety procedures and equipped with the proper tools and test instruments.
- Failure to carefully read and follow all instructions in this manual can result in equipment malfunction, property damage, personal injury and/or death.

CAUTION: Improper installation, adjustment, alteration, service or maintenance can void the warranty. The weight of the condensing unit requires caution and proper handling procedures when lifting or moving to avoid personal injury. Use care to avoid contact with sharp or pointed edges.

Safety Precautions

- Always wear safety eye wear and work gloves when installing equipment.
- Never assume electrical power is disconnected. Check with meter and equipment.
- Keep hands out of fan areas when power is connected to equipment.
- R-410A causes frostbite burns.
- R-410A is toxic when burned.

NOTE TO INSTALLING DEALER: The Owners Instructions and Warranty are to be given to the owner or prominently displayed near the indoor Furnace/Air Handler Unit.

⚠ SPECIAL WARNINGS

When wiring:

Electrical shock can cause severe personal injury or death. Only a qualified, experienced electrician should attempt to wire this system.

- Do not supply power to the unit until all wiring and tubing are completed or reconnected and checked.
- Highly dangerous electrical voltages are used in this system. Carefully refer to the wiring diagram and these instructions when wiring. Improper connections and inadequate grounding can cause accidental injury or death.
- Ground the unit following local electrical codes.
- Connect all wiring tightly. Loose wiring may cause overheating at connection points and a possible fire hazard.
- The choice of materials and installations must comply with the applicable local/national or international standards.

When transporting:

Be careful when picking up and moving the indoor and outdoor units. Get a partner to help, and bend your knees when lifting to reduce strain on your back. Sharp edges or thin aluminum fins on the air conditioner can cut your finger.

When installing...

- ... **in a wall:** Make sure the wall is strong enough to hold the unit's weight. It may be necessary to construct a strong wood or metal frame to provide added support.
- ... **in a room:** Properly insulate any tubing run inside a room to prevent "sweating" that can cause dripping and water damage to wall and floors.
- ... **in moist or uneven locations:** Use a raised concrete pad or concrete blocks provide a solid, level foundation for the outdoor unit. This prevents water damage and abnormal vibration.
- ... **in an area with high winds:** Securely anchor the outdoor unit down with bolts and a metal frame. Provide a suitable air baffle.
- ... **in a snowy area(for Heat Pump Model):** Install the outdoor unit on a raised platform that is higher than drifting snow. Provide snow vents.

When connecting refrigerant tubing

- Keep all tubing runs as short as possible.
- Use the flare method for connecting tubing.
- Check carefully for leaks before starting the test run.

When servicing

- Turn the power OFF at the main power box(mains) before opening the unit to check or repair electrical parts and wiring.
- Keep your fingers and clothing away from any moving parts.
- Clean up the site after you finish, remembering to check that no metal scraps or bits of wiring have been left inside the unit being serviced.

TABLE OF CONTENTS

4 SAFETY INSTRUCTIONS

6 FEATURES

7 Duct Connection Dimensions

8 INSTALLATION

8 Selection of the best location

9 Upflow Installation

10 Downflow Installation

12 Horizontal-Right Installation

13 Duct work

14 Horizontal-left Installation

15 Combination indoor units (Multi Zone)

16 Flaring work

17 Connection of piping - Indoor, Outdoor, BD Unit

18 Plumbing materials and storage methods

19 Insulation

20 Condensate Drain

22 Wiring Connection

24 REMOTE CONTROLLER INSTALLATION

26 Wired remote controller installation

27 3RD PARTY THERMOSTAT

28 INTERNAL ELECTRIC HEATER(Accessory)

29 DIP SWITCH SETTING OF INDOOR UNIT PCB

30 PRODUCT DATA

30 External Static Pressure & Air Flow

30 Minimum airflow by heater capacity

Safety Instructions

The following safety guidelines are intended to prevent unforeseen risks or damage from unsafe or incorrect operation of the appliance.

The guidelines are separated into 'WARNING' and 'CAUTION' as described below.



This symbol is displayed to indicate matters and operations that can cause risk. Read the part with this symbol carefully and follow the instructions in order to avoid risk.



WARNING

This indicates that the failure to follow the instructions can cause serious injury or death.



CAUTION

This indicates that the failure to follow the instructions can cause the minor injury or damage to the product.



WARNING

Installation

- Do not use a defective or underrated circuit breaker. Use this appliance on a dedicated circuit.
 - There is risk of fire or electric shock.
- For electrical work, contact the dealer, seller, a qualified electrician, or an Authorized Service Center.
 - Do not disassemble or repair the product. There is risk of fire or electric shock.
- Always ground the product.
 - There is risk of fire or electric shock.
- Install the panel and the cover of control box securely.
 - There is risk of fire or electric shock.
- Always install a dedicated circuit and breaker.
 - Improper wiring or installation may cause fire or electric shock.
- Use the correctly rated breaker or fuse.
 - There is risk of fire or electric shock.
- Do not modify or extend the power cable.
 - There is risk of fire or electric shock.
- Do not let the air conditioner run for a long time when the humidity is very high and a door or a window is left open.
 - Moisture may condense and wet or damage furniture.
- Be cautious when unpacking and installing the product.
 - Sharp edges could cause injury. Be especially careful of the case edges and the fins on the condenser and evaporator.
- For installation, always contact the dealer or an Authorized Service Center.
 - There is risk of fire, electric shock, explosion, or injury.
- Do not install the product on a defective installation stand.
 - It may cause injury, accident, or damage to the product.
- Be sure the installation area does not deteriorate with age.
 - If the base collapses, the air conditioner could fall with it, causing property damage, product failure, and personal injury.

- Use a vacuum pump or Inert (nitrogen) gas when doing leakage test or air purge. Do not compress air or Oxygen and do not use Flammable gases. Otherwise, it may cause fire or explosion.
 - There is the risk of death, injury, fire or explosion.

Operation

- Do not store or use flammable gas or combustibles near the product.
 - There is risk of fire or failure of product.



CAUTION

Installation

- Always check for gas (refrigerant) leakage after installation or repair of product.
 - Low refrigerant levels may cause failure of product.
- Install the drain hose to ensure that water is drained away properly.
 - A bad connection may cause water leakage.
- Keep level even when installing the product.
 - To avoid vibration or water leakage.
- Do not install product where noise or air flow from the outdoor unit could disturb neighbors.
 - It may cause a problem for your neighbors.
- Use two or more people to lift and transport the product.
 - Avoid personal injury.
- Do not install the product where it will be exposed to sea wind (salt spray) directly.
 - It may cause corrosion on the product. Corrosion, particularly on the condenser and evaporator fins, could cause product malfunction or inefficient operation.
- Safely dispose of the packing materials.
 - Packing materials, such as nails and other metal or wooden parts, may cause stabs or other injuries.
 - Tear apart and throw away plastic packaging bags so that children may not play with them. If children play with a plastic bag which was not torn apart, they face the risk of suffocation.

Features

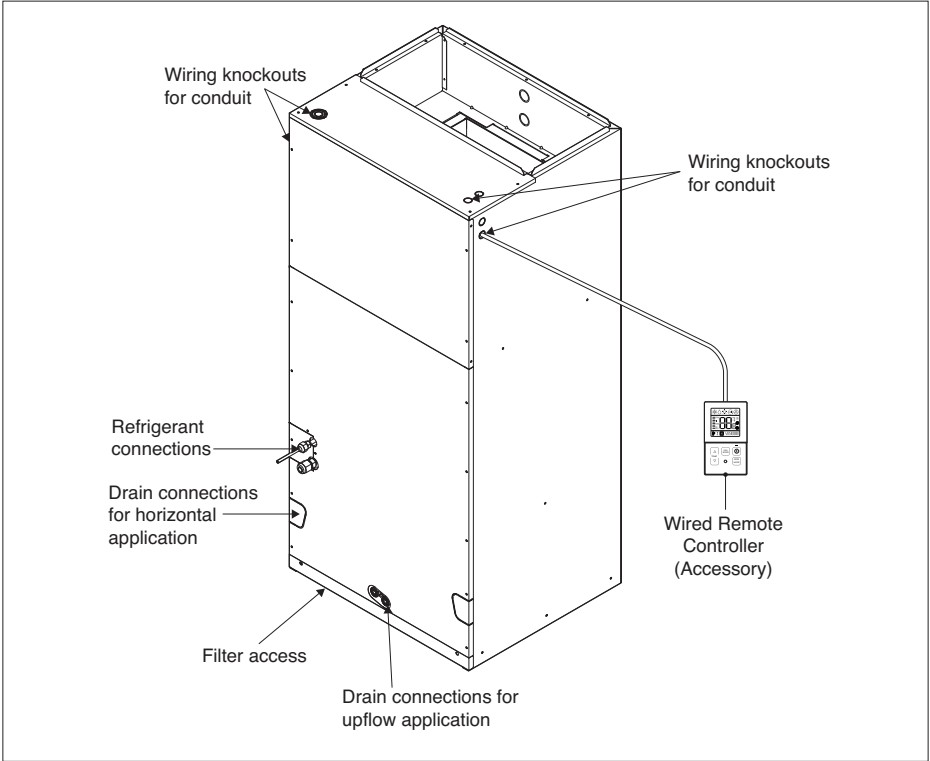

Duct Connection Dimensions

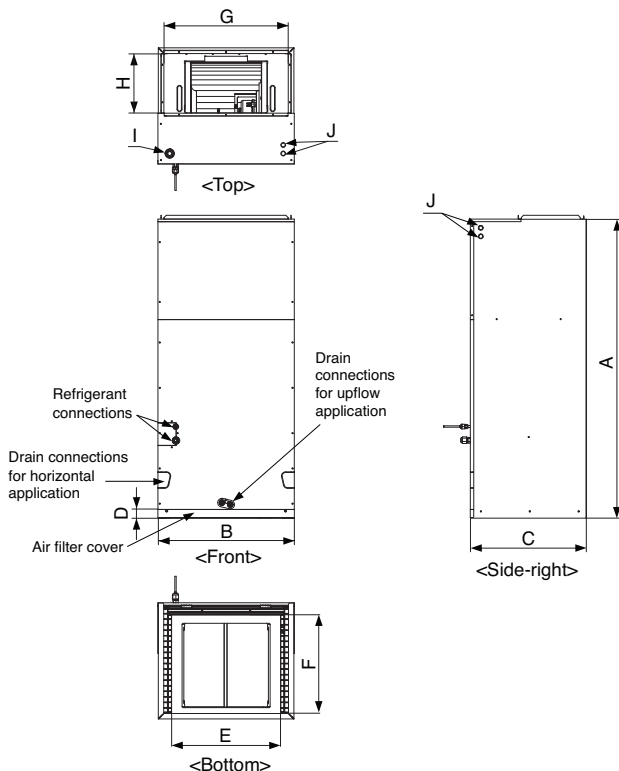

(Unit: inch(mm))

ODU	Capacity (kBtu/h)	Dimensions								Wiring Knock out		Refrigerant Connections Pipe size	
		A	B	C	D	E	F	G	H	I	J	Liquid	Gas
		Height	Width	Depth						Power	Commu- nication		
Single Zone	12												
	18 24 30 36	48-5/8 (1 236)	18 (457)	21-1/4 (540)	1-9/16 (40)	17-1/2 (445)	20 (530)	17 (432)	12-1/8 (308)	1-11/16 (43)	7/8 (22)	3/8 (9.52)	5/8 (15.88)
Multi Zone	42												
	48 60	55-3/16 (1 401)	25 (635)	21-1/4 (540)	1-9/16 (40)	24-1/2 (623)	20 (530)	24 (610)	12-1/8 (308)	1-11/16 (43)	7/8 (22)	3/8 (9.52)	5/8 (15.88)
Multi Zone	18												
	24	48-5/8 (1 236)	18 (457)	21-1/4 (540)	1-9/16 (40)	17-1/2 (445)	20 (530)	17 (432)	12-1/8 (308)	1-11/16 (43)	7/8 (22)	1/4 (6.35)	1/2 (12.7)
	36	48-5/8 (1 236)	18 (457)	21-1/4 (540)	1-9/16 (40)	17-1/2 (445)	20 (530)	17 (432)	12-1/8 (308)	1-11/16 (43)	7/8 (22)	3/8 (9.52)	5/8 (15.88)

Installation

Selection of the best location

- Where optimum air distribution can be ensured.
- Where nothing blocks air passage and install the duct work.
- Where condensate can be properly drained.
- Where the ceiling is strong enough to bear the indoor unit weight.
- Where the false ceiling is not noticeably on an incline.
- Where sufficient clearance for maintenance and service can be ensured.
- Where piping between indoor and outdoor units is possible within the allowable limit. Refer to the installation manual for the outdoor unit.
- Vertical Air Handling Unit can be installed for upflow and horizontal-left positions.

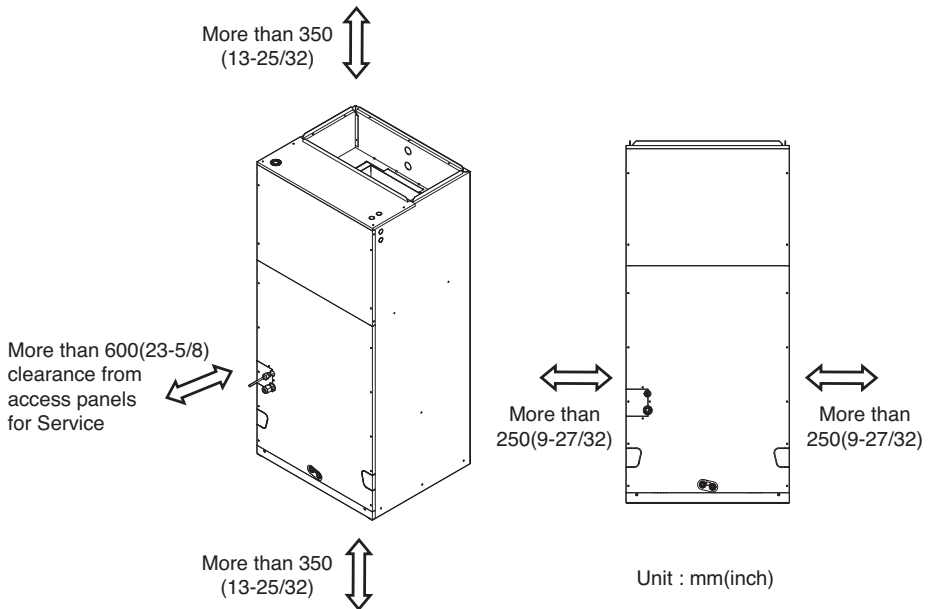

NOTE : The primary and secondary drain line must be trapped to allow proper drainage of condensate water, If the secondary drain line is not used, it must be capped.

CAUTION

In the case of sea coast installation, salt residue may cause corrosion of cabinet and component parts. Please take appropriate anti-corrosion measures.

Upflow Installation

- Position unit for plenum installation.
- The plenum should be secured in order to support the installation of adapter callers accommodate the installation of any duct work.
- Seal all duct work according to local codes to prevent air leakage. Ensure that filter access is unobstructed.
- The air handler support platform should be sturdy enough to support the cabinet plus any accessory components including filter box.
- The minimum height clearance is 14 inches(350 mm) to maintain proper air flow.
- Vibration isolators (purchased locally) must be placed between the unit and the pedestal.
- An illustration showing an example of where a vibration isolator should be added would clarify what the installing contractor should do to properly position the isolator.

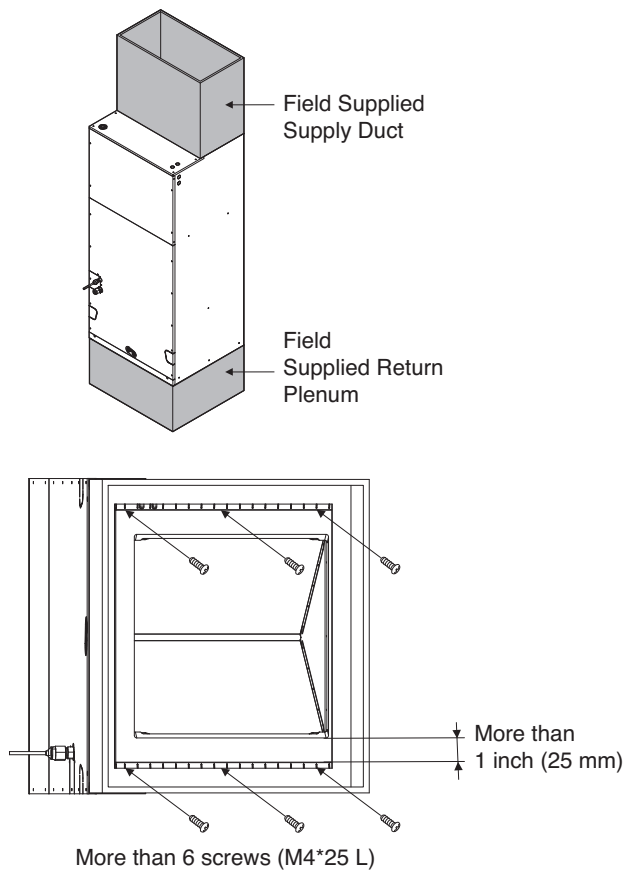

CAUTION

Do not connect the screws on Front and Rear side, it may cause the filter can not be mounted.

Downflow Installation

Downflow installation requires various changes to the air handling unit from original configuration. There are additional kits required in order to convert the air handling unit to the downflow configuration.

1) Please remove the panels and Brackets from the unit.

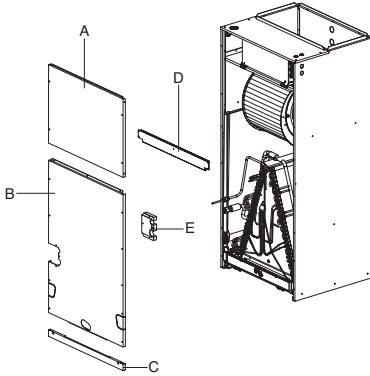

2) Please remove the thermistor from a coil. Also remove a coil and Drain pan from the unit

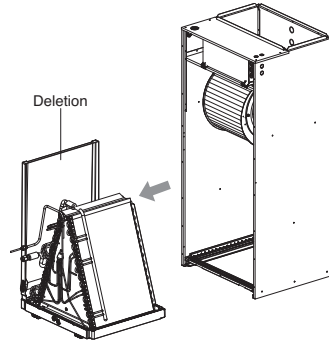

3) Rotate the cabinet.

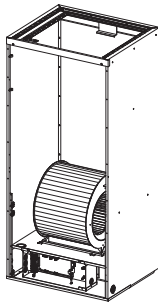

4) Please assemble the downflow bracket as below. Install the bracket in the order shown and fix with screw.

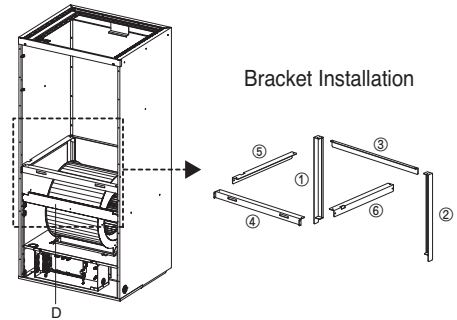

5) Reinsert the coil back to the cabinet.

Before this action, please route the thermistor wires into the downflow Bracket

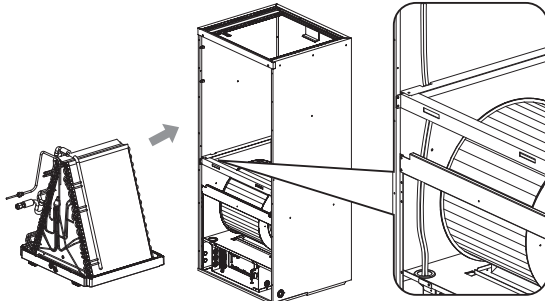

6) The brackets are required to be reattached.

7) Reinstall the new panel.

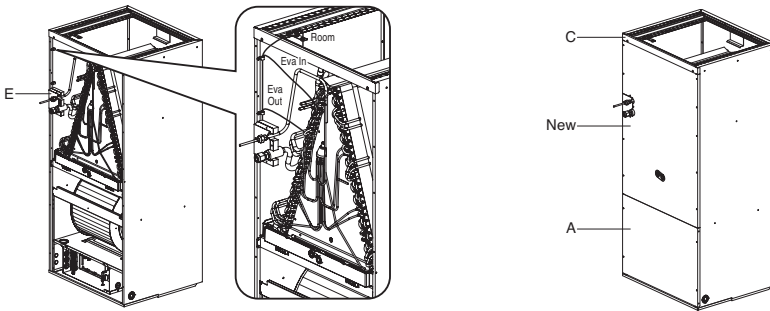

Horizontal-Right Installation

Downflow installation requires various changes to the air handling unit from original configuration. There are additional kits required in order to convert the air handling unit to the downflow configuration.

1) Please remove the panels and Brackets from the unit.

2) Please remove the thermistor from a coil. Also remove a coil and Drain pan from the unit.

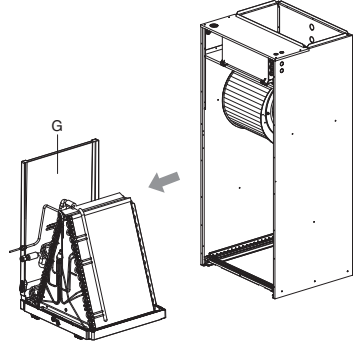
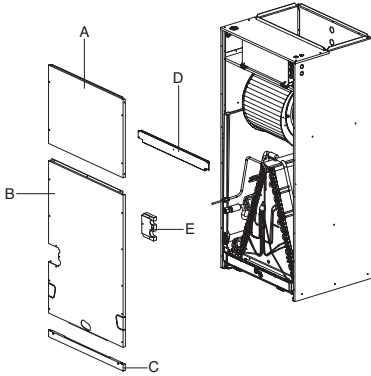

3) Rotate the drain pan.

4) Reinstall brackets and panel.

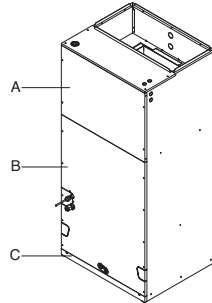
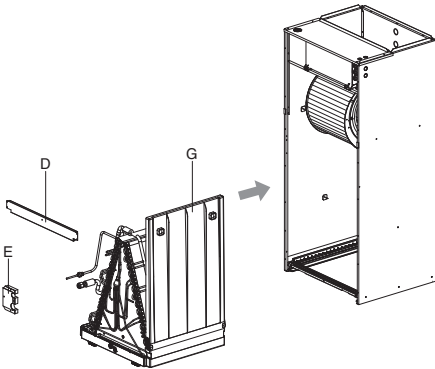

Duct work

- Over 10 screws should be used for joining supply duct with the unit.
- To prevent vibration transmission, exploit flexible connectors between duct and the unit. It is mandatory that the flexible connector between unit and duct at discharge connection should be made off heat resistive material when electric heater is installed.
- Duct work must be insulated and covered with vapor barrier when routed through unconditioned space.
- To prevent the formation of condensation, insulate the duct well.
- Internal acoustical insulation lining may necessary for the metal duct system if it do not have 90° elbow and 10 ft. of main duct to first branch takeoff.
- It is advised that a fibrous duct work could be used as a substitute if built and installed in accordance with the most recent edition of SMACNA construction standard on fibrous glass ducts.
- Collectively fibrous duct work and acoustical lining shall obey National Fire Protection Association standards 90 A or B as tested by UL standard 181 for class 1 air ducts.
- Seal around the delivery duct subsequent to when the duct is secured so that to facilitate prevention of air leakage.

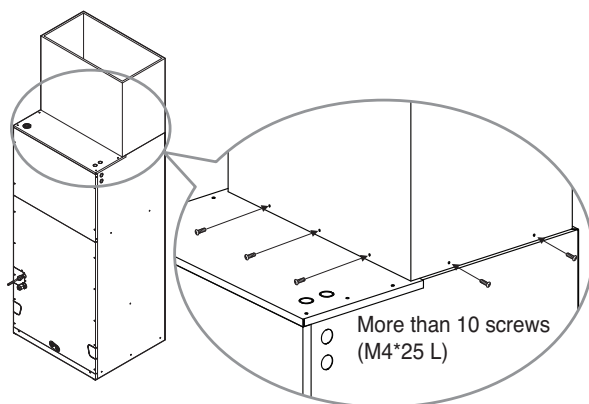

Horizontal-left Installation

- It is particular that the units should not be installed in such a manner that the access panels facing up or down
- It should be confirmed that the installation is in accordance with all relevant building codes that may necessitate installation of external condensate pan.
 - Set up a support for unit by locating it in or above external condensate pan.
- Angle steel support brackets with threaded rods which supporting the units from the underside should be used as shown in the figure below if the units are suspended.
- If not suspended then also it should be supported as same as mentioned above and also carefully isolated to avoid sound transmission. The size of the support should comparatively bigger than the unit and the unit must be place at center of the support.
- Locally available vibration isolators must be placed between the unit and the support.
- The same installation method of up flow type has to be used in the case of Return Plenum and supply duct.

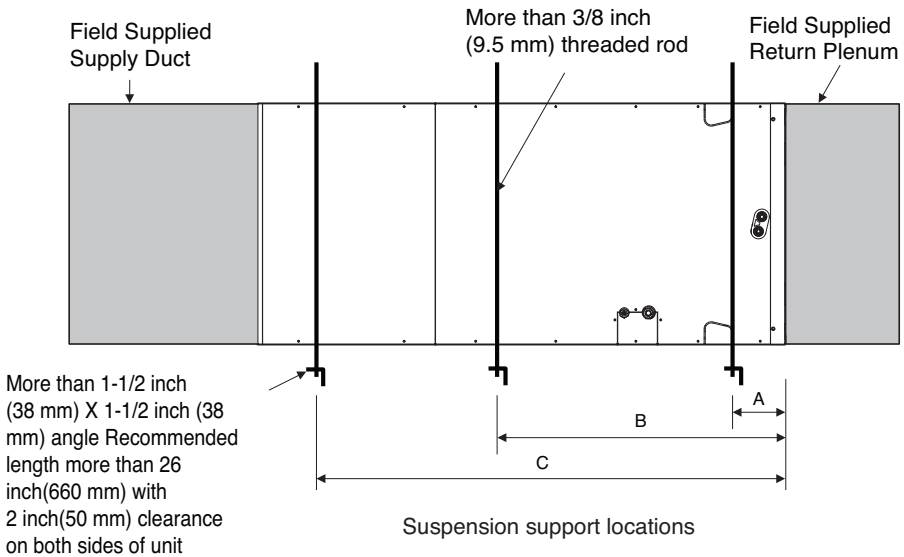

(Unit : inch(mm))

ODU	Capacity (kBtu/h)	Dimension		
		A	B	C
Single Zone	12	4(100)	23(580)	41-11/32 (1 050)
	18			
	24			
	30			
	36			
	42			
Multi Zone	48	4(100)	29(730)	48(1 220)
	60			
	18			
Multi Zone	24	4(100)	23(580)	41-11/32 (1 050)
	36			

CAUTION

To ensure proper drainage for horizontal installations, unit must be installed so it is within 1/8" level of the length and width of unit.

Combination indoor units (Multi Zone)

The indoor units connectable to the outdoor unit are shown below

Indoor Unit		Outdoor Unit (kBtu/h)	
Type	Capacity (kBtu/h)	36	54
Vertical AHU	18 / 24	O	O
	36	X	O
Ceiling Concealed Duct (High Static)	24	O	O
	36	X	O

- NOTICE** :
1. The total capacity(in Btu/h unit) of connected indoor unit models represents the total sum of the figures expressed in the indoor model name.
 2. Combinations in which the total capacity of the connected indoor units exceeds the capacity of the outdoor unit will reduce the capacity of each indoor unit below the rated capacity during simultaneous operation. Therefore, if circumstances allows, combine indoor units within the capacity of the outdoor unit.
 3. VAHU, Ceiling Concealed Duct(High Static) type indoor unit's combination calculation method as below.
Calculation method for total capacity of connectable indoor unit to an outdoor unit = (Sum of all VAHU & Ceiling Concealed Duct(High Static) type indoor units capacity x 1.3) + Sum of all other indoor unit's capacity

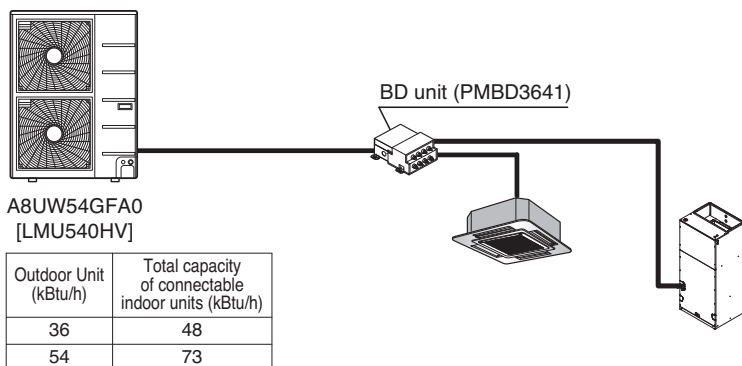

Example)

4Way CST AMNW18GTQA0 [LMCN185HV]	+	VAHU AMNW36GNJA0 [LMVN360HV]
--	---	------------------------------------

Total rated capacity index : 18 + 36 x 1.3 = 64.8 < 73

Flaring work

Main cause of gas leakage is defect in flaring work. Carry out correct flaring work in the following procedure.

1) Cut the pipes

- Use the accessory piping kit or the pipes purchased locally.
- Measure the distance between the indoor and the outdoor unit.
- Cut the pipes a little longer than measured distance.
- Cut the cable 1.5 m (4.9 ft) longer than the pipe length.

2) Burrs removal

- Completely remove all burrs from the cut cross section of pipe/tube.
- Put the end of the copper tube/pipe to downward direction as you remove burrs in order to avoid to let chips drop in the tubing.

3) Putting nut on

- Remove flare nuts attached to indoor and outdoor units, than put them on pipe/tube having completed burr removal.
- (Not possible to put them on after flaring work)

4) Flaring work

- Carry out flaring work using flaring tool as shown below.

Pipe diameter Inch (mm)	A Inch (mm)		Thickness Inch (mm)
	Wing nut type	Clutch type	
Ø 1/4 (Ø 6.35)	0.04~0.05 (1.1~1.3)	0~0.02 (0~0.5)	0.03 (0.7)
Ø 3/8 (Ø 9.52)	0.06~0.07 (1.5~1.7)		0.03 (0.8)
Ø 1/2 (Ø 12.7)	0.06~0.07 (1.6~1.8)		0.03 (0.8)
Ø 5/8 (Ø 15.88)	0.06~0.07 (1.6~1.8)		0.04 (1.0)
Ø 3/4 (Ø 19.05)	0.07~0.08 (1.9~2.1)		0.04 (1.0)

Firmly hold copper tube in a bar (or die) as indicated dimension in the table above.

5) Check

- Compare the flared work with figure.
- If flare is noted to be defective, cut off the flared section and do flaring work again.

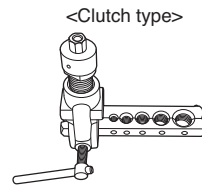
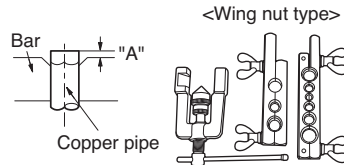
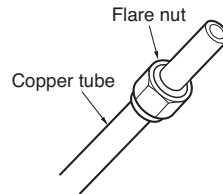
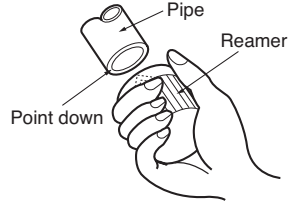
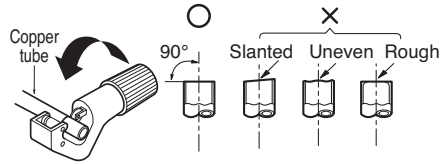

Smooth all round
Inside is shining without scratches.

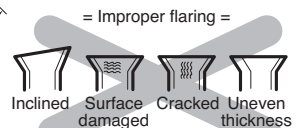
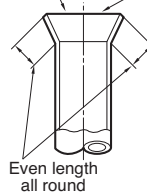

Connection of piping - Indoor, Outdoor, BD Unit

Align the center of the piping and sufficiently tighten the flare nut by hand.

ODU	Indoor Unit Capacity (kBtu/h)	Installed pipe size (inch (mm))	
		Liquid	Gas
Single Zone	12	1/4 (Ø 6.35)	3/8 (Ø 9.52)
	18	3/8 (Ø 9.52)	5/8 (Ø 15.88)
	24		
	30		
	36		
	42		
48			
Multi Zone	60	3/8 (Ø 9.52)	3/4 (Ø 19.05)
	18	1/4 (Ø 6.35)	1/2 (Ø 12.7)
	24	1/4 (Ø 6.35)	1/2 (Ø 12.7)
	36	3/8 (Ø 9.52)	5/8 (Ø 15.88)

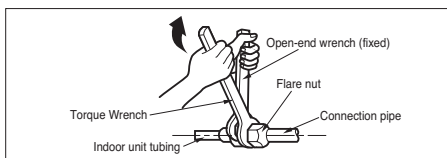
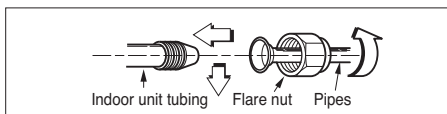

For Multi Zone ODU

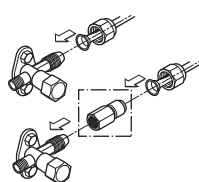

For Single Zone IDU

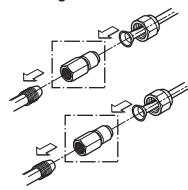

(Only Indoor Units 12 / 18 / 24 kBtu/h)

BD Unit	Connections Size (inch (mm))		Connectable Indoor Unit Capacity (kBtu/h)
	Liquid	Gas	
PMBD3620	1/4 (Ø 6.35) x 2 EA	3/8 (Ø 9.52) x 2 EA	18/24
PMBD3630	1/4 (Ø 6.35) x 3 EA	3/8 (Ø 9.52) x 3 EA	18/24
PMBD3640	1/4 (Ø 6.35) x 4 EA	3/8 (Ø 9.52) x 4 EA	18/24
PMBD3641	1/4 (Ø 6.35) x 4 EA	3/8 (Ø 9.52) x 3 EA	18/24 (A/B/C ROOM)
		1/2 (Ø 12.7) x 1 EA	36 (D ROOM)

* BD Unit(PMBD3641) includes the sockets.
(Ø 12.7 → Ø 15.88 x 1 EA, Ø 6.35 → Ø 9.52 x 1 EA)

* Indoor Unit (18/24 k) includes the sockets.
Ø 6.35 → Ø 9.52 x 1 (for Single)
Ø 12.7 → Ø 15.88 x 1 (for Single)
Ø 9.52 → Ø 12.7 x 1 (for Multi ODU)

Finally, tighten the flare nut with torque wrench until the wrench clicks.

- When tightening the flare nut with torque wrench ensure the direction for tightening follows the arrow on the wrench.

Outside diameter		Torque		
mm	inch	N-m	kgf-m	lbf-ft
Ø 6.35	1/4	14~18	1.4~1.8	10~13
Ø 9.52	3/8	34~42	3.5~4.3	25~31
Ø 12.7	1/2	49~61	5.0~6.2	36~45
Ø 15.88	5/8	69~82	7.0~8.4	51~60
Ø 19.05	3/4	100~120	10.0~12.2	73~88

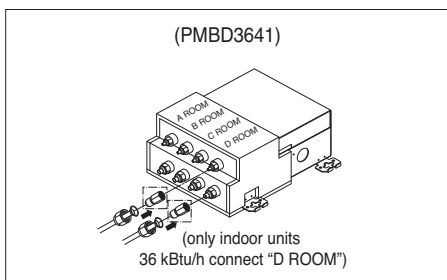
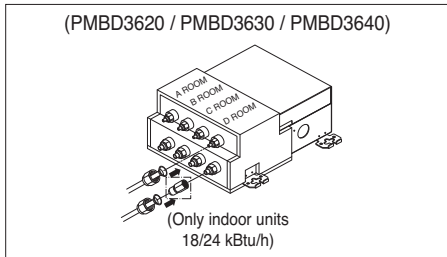

⚠ CAUTION

Always blow nitrogen into pipe which is brazed. Always use a non-oxidizing brazing material for brazing the parts and do not use flux. If not, oxidized film can cause clogging or damage to the compressor unit and flux can harm the copper piping or refrigerant oil.

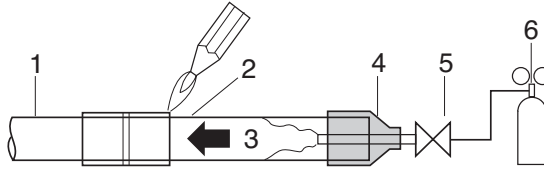

1	Refrigerant piping	4	Taping
2	Pipe to be brazed	5	Valve
3	Nitrogen	6	Pressure-reducing valve

Note : The torch tip should be positioned at the opposite angle to show the correct way to apply heat on the pipe coupling.

Plumbing materials and storage methods

Pipe must be able to obtain the specified thickness and should be used with low impurities.

Also when handling storage, pipe must be careful to prevent a fracture, deformity and wound.

Should not be mixed with contaminations such as dust, moisture.

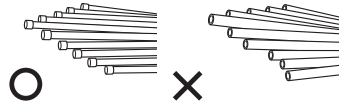

Refrigerant piping on three principles

	Drying Should be no moisture inside	Cleanliness No dust inside.	Airtight There is no refrigerant leakage
Items			
Cause failure	<ul style="list-style-type: none"> - Significant hydrolysis of refrigerant oil - Degradation of refrigerant oil - Poor insulation of the compressor - Do not cold and warm - Clogging of EEV, Capillary 	<ul style="list-style-type: none"> - Degradation of refrigerant oil - Poor insulation of the compressor - Do not cold and warm - Clogging of EEV, Capillary 	<ul style="list-style-type: none"> - Gas shortages - Degradation of refrigerant oil - Poor insulation of the compressor - Do not cold and warm
Countermeasure	<ul style="list-style-type: none"> - No moisture in the pipe - Until the connection is completed, the plumbing pipe entrance should be strictly controlled. - Stop plumbing at rainy day. - Pipe entrance should be taken side or bottom. - When removal burr after cutting pipe, pipe entrance should be taken down. - Pipe entrance should be fitted cap when pass through the walls. 	<ul style="list-style-type: none"> - No dust in the pipe. - Until the connection is completed, the plumbing pipe entrance should be strictly controlled. - Pipe entrance should be taken side or bottom. - When removal burr after cutting pipe, pipe entrance should be taken down. - Pipe entrance should be fitted cap when pass through the walls. 	<ul style="list-style-type: none"> - Airtightness test should be. - Brazing operations to comply with standards. - Flare to comply with standards. - Flange connections to comply with standards.

Insulation

Insulate the joint and tubes completely.

Thermal Insulation : All thermal insulation must comply with local requirement.

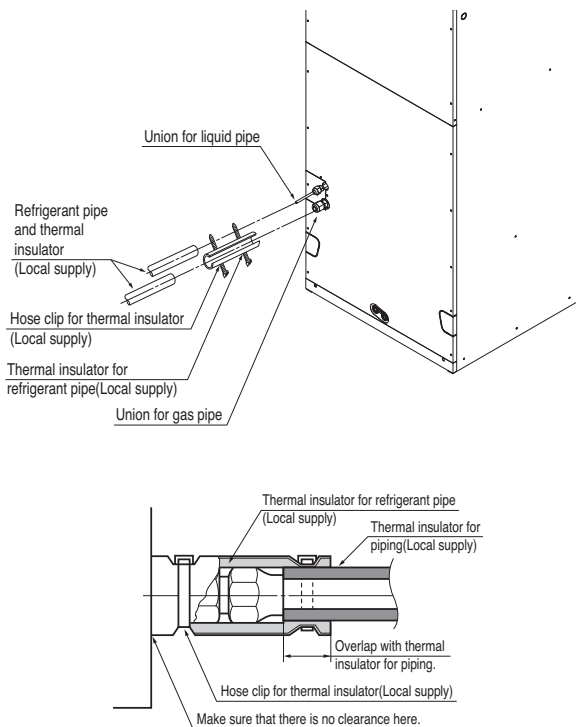

1. Use the heat insulation material for the refrigerant piping which has an excellent heat-resistance [over 120 °C(248 °F)].

2. Precautions in high humidity circumstance:

This air conditioner has been tested according to the "KS Standard Conditions with Mist" and confirmed that there is not any default. However, if it is operated for a long time in high humid atmosphere [dew point temperature: more than 23 °C(73.4 °F)], water drops are liable to fall. In this case, add heat insulation material according to the following procedure:

- Heat insulation material to be prepared... Adiabatic glass wool with thickness 0.4 inch(10 mm) to 0.8 inch(20 mm).
- Stick glass wool on all air conditioners that are located in a house attic.

Condensate Drain

- The drainage performance has to be optimized by installing both primary and secondary drain lines along with properly sized condensate traps in order to prevent property damage.
 - Care should be taken to avoid the blocking of filter access panel while connecting condensate drain lines. The primary and secondary condensate traps has to be primed after connecting to the drain pan.
- ※ **A field supplied external condensate pan has to be installed underneath the entire unit if the unit is above the living space . Other wise damage may result due to condensate over flow. Also a additional external condensate line should run from unit in to the pan.**
- The entire condensate should be drained from the external condensate pan to some noticeable area. It is advised to install traps in condensate lines as near to the coil as possible. The outlet of each trap should be below its connection to the condensate pan avert condensate from overflowing drain pan.
 - If located above the living area then all traps should be prime and insulated and also tested for leakage.
 - PVC 3/4 inch(19.05 mm) male pipe thread fitting is advised to use at condensate pan with gentle tight.
 - For easy drain flow the drain hose has to be pointed downward.
 - Care should be taken to not use pipe joint connection or PVC/CPVC for units drain line connection. Use only Teflon tape.
 - For preventing winter freeze up on condensate line special means should be provided for drainage.

Case I (Upflow/Downflow)

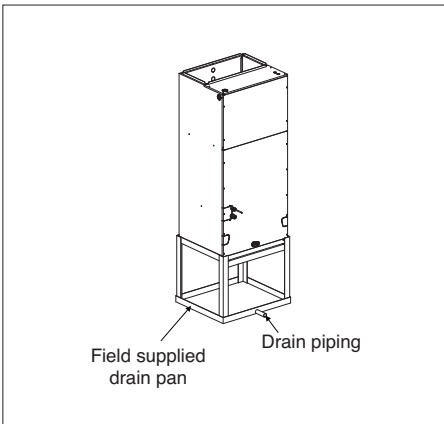

Case II (Right/Left)

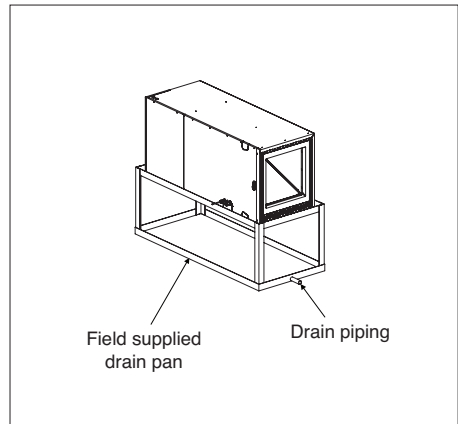

GRADIENT OF UNIT AND DRAIN PIPING

- Always lay the drain with downward inclination (1/50 to 1/100). Prevent any upward flow or reverse flow in any part.
- 5/24 inch (5 mm) or thicker formed thermal insulator shall always be provided for the drain pipe.

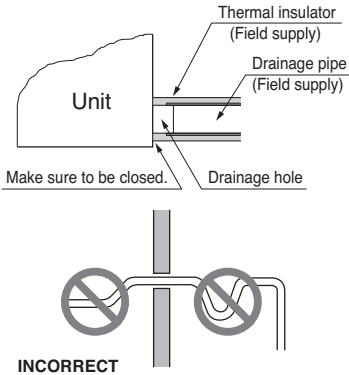

Applied U-Trap Dimension

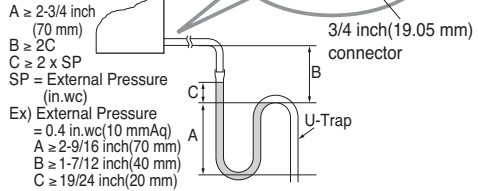

CORRECT

- Install the U-Trap to prevent a water leakage caused by the blocking of intake air filter.

Upflow Drain

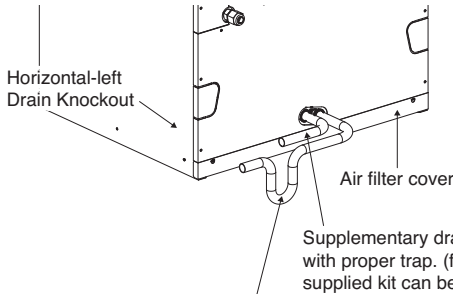

Main drain along with suitable trap. (Field supplied trap with sufficient depth can be used. P-traps of standard size are not sufficient. Refer the figure for recommended condensate trap.)

Horizontal-left Drain

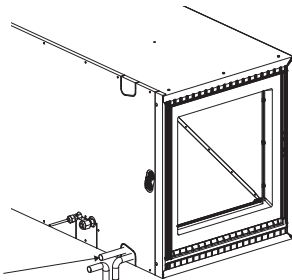

CAUTION

The supplied flexible drain hose should not be strained. A strained hose may cause leakage of water.

Wiring Connection

Connect the wires to the terminals on the control board individually according to the outdoor unit connection.

Ensure that the color of the wires of outdoor unit and the terminal No. are the same as those of indoor unit respectively.

208/230 V 1Φ 60 Hz

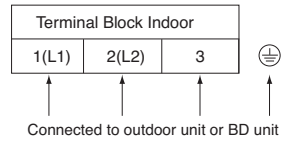

■ Connecting cable

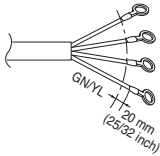

The power connecting cable between the outdoor and indoor units must comply with the following specifications: NRTL Recognized (for example, UL or ETL recognized and CSA certified).

AWG 18 (0.75 mm²)-4 is the minimum recommended wire size, however, the selected conductors must comply with local codes and be suitable for installation in wet locations.

■ Precautions when laying power and ground wiring

Use round pressure terminals for connections to the power terminal block. When none are available, follow the instructions below.

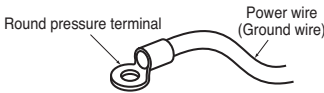

- Do not connect wiring of different thicknesses to the power terminal block. (Slack in the power wiring may cause abnormal heat.)
- When connecting wiring which is the same thickness, do as shown in the figure below.



- For wiring, use the designated power wire and connect firmly, then secure to prevent outside pressure being exerted on the terminal block.
- Use an appropriate screwdriver for tightening the terminal screws. A screwdriver with a small head will strip the head and make proper tightening impossible.
- Over-tightening the terminal screws may break them.

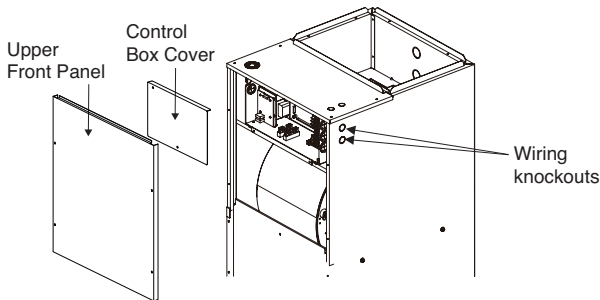

1. Detach the upper panel & control box cover. And remove two wiring Knockouts.

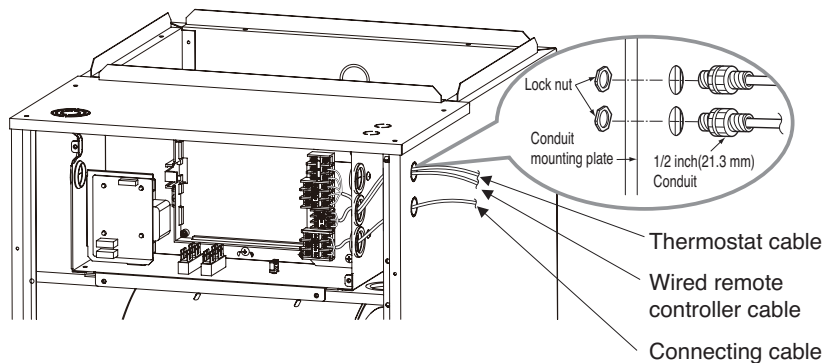

2. Install conduit to the wiring knockouts.

Connect connecting / wired remote controller cable or Thermostat cable to terminal block through the wiring knockouts.

NOTICE :

1. Use connection cable NRTL(UL, ETL, CAS...) listed and stranded copper(4) THHN conductors, sunlight (UV) resistant ROHS compliant PVC jacket 600 V direct burial listed, approved for wet conditions. Temperature rated for -20 °C(-4 °F) to 90 °C(194 °F). And this cable should be enclosed in conduit.

⚠ WARNING

- Be sure to comply with local and national codes while running the wire from the indoor unit to the outdoor unit(size of wire and wiring method, etc).
- Every wire must be connected firmly.
- No wire should be allowed to touch refrigerant tubing, the compressor or any moving parts.
- The communication wirings of air conditioner should be separate and isolated from external device's electric wiring such as computers, elevator, radio & Television broadcasting facilities, as well as medical imaging offices.

HAND OVER

Teach the customer the operation and maintenance procedures, using the operation manual. (air filter cleaning, temperature control, etc.)

NOTE : Openings where field wiring enters the cabinet must be completely sealed.

Remote controller installation

※ Remote controller is provided as an accessory.

Please fix tightly using provided screw after placing remote controller setup board on the place where you like to setup.

- Please set it up not to bend because poor setup could take place if setup board bends.
- Please set up remote controller board fit to the reclamation box if there is a reclamation box.

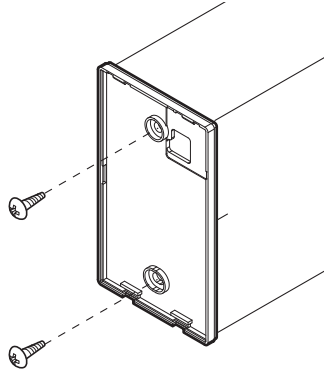

Can set up Wired remote controller cable into three directions.

- Setup direction: the surface of wall reclamation, upper, right
- If setting up remote controller cable into upper and right side, please set up after removing remote controller cable guide groove.

* Remove guide groove with long nose.

- ① Reclamation to the surface of the wall
- ② Upper part guide groove
- ③ Right part guide groove

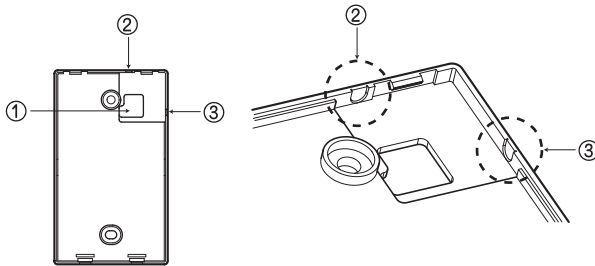

<Wire guide grooves>

Please connect indoor unit and remote controller using connection cable.

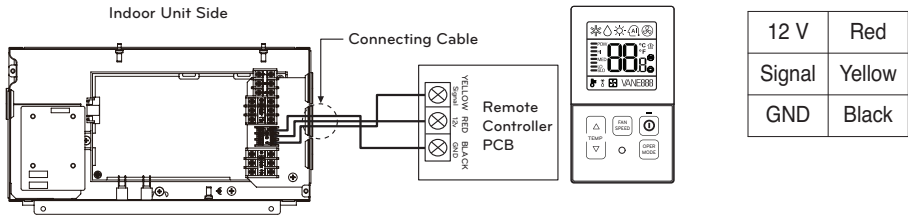

Please use extension cable if the distance between wired remote controller and indoor unit is more than 10 m(32-4/5 ft).

Please fix remote controller upper part into the setup board attached to the surface of the wall, as the picture below, and then, connect with setup board by pressing lower part.

- Please connect not to make a gap at the remote controller and setup board's upper and lower, right and left part.

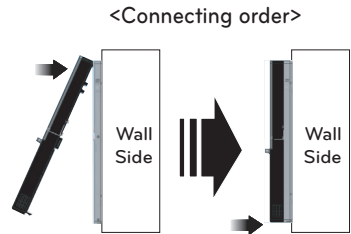

When separating remote controller from setup board, as the picture below, after inserting into the lower separating hole using screw driver and then, spinning clockwise, remote controller is separated.

- There are two separating holes. Please individually separate one at a time.
- Please be careful not to damage the inside components when separating.

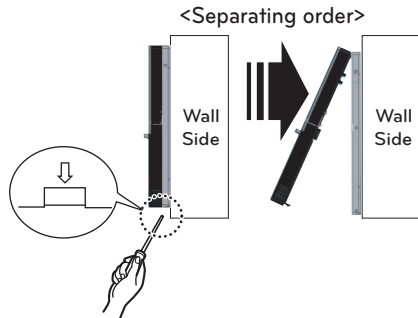

⚠ CAUTION

When installing the wired remote controller, do not bury it in the wall.

(It can cause damage in the temperature sensor.)

Do not install the cable to be 50 m or above.

(It can cause communication error.)

- When installing the extension cable, check the connecting direction of the connector of the remote controller side and the product side for correct installation.
- If you install the extension cable in the opposite direction, the connector will not be connected.
- Specification of extension cable: 2547 1007 22# 2 core 3 shield 5 or above.
- Apply totally enclosed noncombustible conduit in case of local building code Requiring plenum cable usage.

Wired remote controller installation

Since the room temperature sensor is in the remote controller, the remote controller box should be installed in a place away from direct sunlight, high humidity and direct supply of cold air to maintain proper space temperature. Install the remote controller about 5 ft(1.5 m) above the floor in an area with good air circulation at an average temperature.

Do not install the remote controller where it can be affected by:

- Drafts, or dead spots behind doors and in corners.
- Hot or cold air from ducts.
- Radiant heat from sun or appliances.
- Concealed pipes and chimneys.
- Uncontrolled areas such as an outside wall behind the remote controller.
- This remote controller is equipped with LCD. display. For proper display of the remote controller LCD's, the remote controller should be installed properly as shown in Fig.1.
(The standard height is 4~5 ft (1.2~1.5 m) from floor level.)

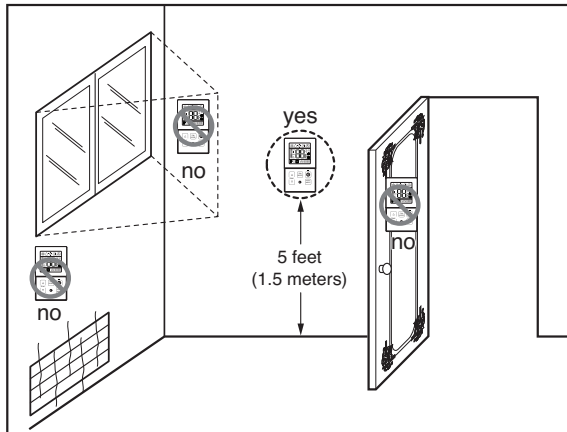

[Fig.1]

⚠ CAUTION

- When using the wired remote controller or central controller provided by LG, should disconnect the wire connector between Indoor unit PCB(CN_CC) and dry contact PCB(CN_INDOOR).

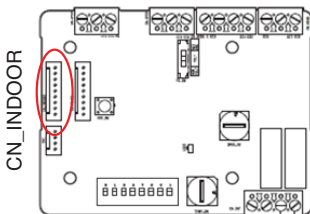

3rd Party Thermostat

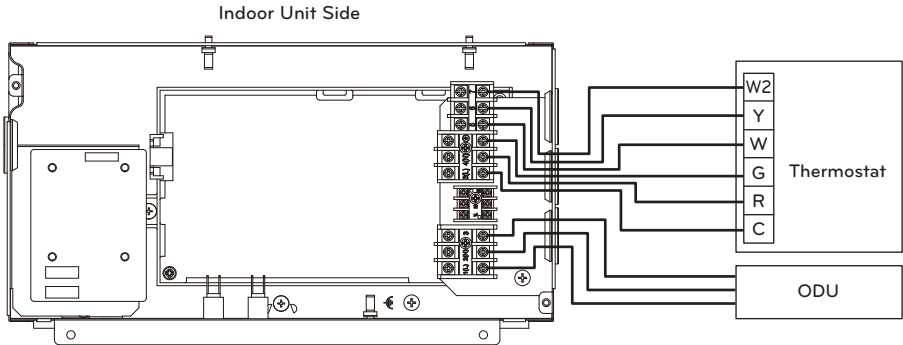

NOTE

- * Can not use LG wired remote control and 3rd party thermostat at the same time.
- * When connecting the thermostat, please refer to the thermostat manual.

Internal Electric Heater(Accessory)

Feature (Example: 5 kW)

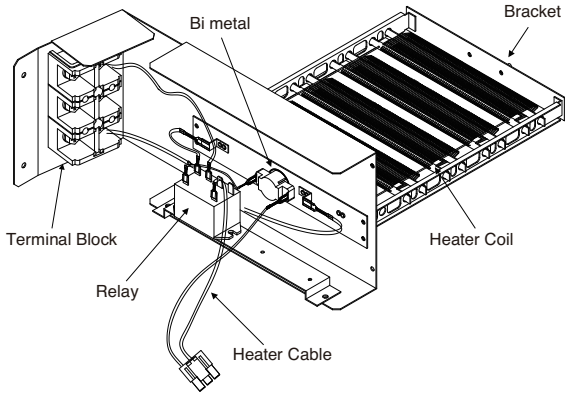

* Note: Image shown above may vary depends on model capacity.

Available heater in model

IDU frame	Capacity (kBtu/h (RT))	Heater Capacity (kW)					
		3	5	8	10	15	20
NJ	12(1.0)	○	○	○	Not available	Not available	Not available
	18(1.5)	○	○	○	○	Not available	Not available
	24(2.0)	○	○	○	○	Not available	Not available
	30(2.5)	○	○	○	○	Not available	Not available
	36(3.0)	○	○	○	○	Not available	Not available
NK	36(3.0)	○	○	○	○	○	○
	42(3.5)	○	○	○	○	○	○
	48(4.0)	○	○	○	○	○	○
	60(5.0)	○	○	○	○	○	○

* If you want to know more optional operation, please refer to the Internal Electric Heater Manual.

* Heater Model

- 3 kW : ANEH033B1
- 5 kW : ANEH053B1
- 8 kW : ANEH083B2
- 10 kW : ANEH103B2
- 15 kW : ANEH153B2
- 20 kW : ANEH203B2

DIP Switch Setting of Indoor unit PCB

	Function	Description	Setting Off	Setting On	Default
SW1	Communication	N/A (Default)	-	-	Off
SW2	Cycle	N/A (Default)	-	-	Off
SW3	Group Control	Selection of Master or Slave	Master	Slave	Off
SW4	Dry Contact Mode	Selection of Dry Contact Mode	Wired/Wireless remote controller Selection of Manual or Auto operation Mode	Auto	Off
SW5	Installation	Fan continuous operation	Continuous operation Removal	-	Off
SW6	Heater linkage	Selection of Heating Working	-	-	Off
SW7	Etc.	Spare	-	-	Off
SW8	Etc.	Spare	-	-	Off

CAUTION

1. Indoor unit without Internal Electric Heater
 - DIP switch 1, 2, 6, 8 must be set OFF.
2. In the case of indoor unit with Internal Electric heater, DIP switch 6 must be set ON.
 - SW6 ON: Automatic Heater operation (Heater operates automatically according to the heater logic without owner's intervene.)
 - SW6 OFF: Heater manual operation (Owner's involvement is required for on/off operation. But the heater operation would be as per the heater logic.)
3. In the case of indoor unit with Internal Electric heater, DIP switch 5 on if you want.
 - SW5 ON: Fan operates continuously. (During defrosting or oil return operation, uninterrupted heating can be attained, as a result of continuous heater and fan operation.
※ During defrosting or oil return operation tepid air can come out.
 - SW5 OFF: Fan discontinuous operation (There would be reduction in heating capacity while defrosting or oil return operation.)

Product Data

External Static Pressure & Air Flow

Capacity (kBtu/h(RT))	Flow rate (CFM)	Setting Value @ ESP(in.wc)									
		0.1	0.2	0.3	0.4	0.5	0.6	0.7	0.8	0.9	1
42 (3.5)	High (1 260)	70	77	83	90	96	98	104	108	116	116
	Middle (1 100)	65	71	79	86	92	96	102	106	114	116
	Low (1 000)	61	67	75	82	88	94	100	104	112	116
48 (4.0)	High (1 400)	77	82	87	94	100	102	106	110	116	116
	Middle (1 260)	70	77	83	90	96	98	104	108	114	116
	Low (1 000)	61	67	75	82	88	94	100	104	112	116
60 (5.0)	High (1475)	77	82	87	93	98	100	105	110	113	115
	Mid (1400)	74	79	84	90	94	96	102	110	113	115
	Low (1260)	67	75	80	87	90	93	98	102	110	115

Notes :

- Air handler units are UL Listed up to 0.5 in.wc external static pressure, including, set coil, and largest kW size heater, unless otherwise noted.
- in.wc = inch Water Column, inAq
High static pressure is 0.3 in.wc (Factory set Default)
Low static pressure is 0.1 in.wc
- If you set ESP incorrectly, the air conditioner may cause cooling & heating capacity down and malfunction.

Minimum airflow by heater capacity

(Unit : CFM)

IDU frame	Capacity (kBtu/h (RT))	Heater Capacity (kW)					
		3	5	8	10	15	20
NJ	12(1.0)	380	380	380	Not available	Not available	Not available
	18(1.5)	480	480	480	480	Not available	Not available
	24(2.0)	480	480	480	480	Not available	Not available
	30(2.5)	800	800	800	800	Not available	Not available
	36(3.0)	800	800	800	800	Not available	Not available
NK	36(3.0)	900	900	900	900	900	900
	42(3.5)	1 000	1 000	1 000	1 000	1 000	1 000
	48(4.0)	1 000	1 000	1 000	1 000	1 000	1 000
	60(5.0)	1 000	1 000	1 000	1 000	1 000	1 000

CAUTION

Do not use less than minimum airflow.

There is risk of fire or damage to the product.



US	Please call the installing contractor of your product, as warranty service will be provided by them.
CANADA	Service call Number # : (888) LG Canada, (888) 542-2623 Numéro pour les appels de service : LG Canada, 1-888-542-2623