



Scan the QR code to see the manual.



OWNER'S MANUAL

AIR PURIFIER



Before beginning installation, read these instructions carefully. This will simplify installation and ensure that the product is installed correctly and safely. Leave these instructions near the product after installation for future reference.

ENGLISH

AS20GP*K0

TABLE OF CONTENTS

This manual may contain images or content that may be different from the model you purchased.
This manual is subject to revision by the manufacturer.

SAFETY INSTRUCTIONS

READ AND SAVE THESE INSTRUCTIONS 3
WARNING INSTRUCTIONS 3
CAUTION INSTRUCTIONS 7

OPERATION

Product Overviews 10
Preparation before Operation 13
Examining Features 17
Operating the Air Purifier 19
Using the Extra Functions 19
Overall Air Quality 22

SMART FUNCTIONS

LG ThinQ Application 23
Smart Diagnosis 24

MAINTENANCE

Maintaining the Product 26

TROUBLESHOOTING

Before Calling for Service 30

APPENDIX

Information 33

SAFETY INSTRUCTIONS

READ AND SAVE THESE INSTRUCTIONS

The following safety guidelines are intended to prevent unforeseen risks or damage from unsafe or incorrect operation of the appliance. The guidelines are separated into 'WARNING' and 'CAUTION' as described below.

Safety Messages



This symbol is displayed to indicate matters and operations that can cause risk.

Read the part with this symbol carefully and follow the instructions in order to avoid risk.



WARNING

This indicates that failure to follow the instructions can cause serious injury or death.



CAUTION

This indicates that failure to follow the instructions can cause minor injury or damage to the product.

WARNING INSTRUCTIONS

WARNING

- To reduce the risk of explosion, fire, death, electric shock, injury or scalding to persons when using this product, follow basic precautions, including the following:

Technical Safety

- This appliance is not intended for use by persons (including children) with reduced physical, sensory or mental capabilities or lack of experience and knowledge, unless they have been given supervision or instruction concerning use of the appliance by a person responsible for their safety.

Children should be supervised to ensure that they do not play with the appliance.

- The fan is not a toy. It should not be played with or placed where young children can reach it.
- If the supply cord is damaged, it must be replaced by the manufacturer, its service agent or similarly qualified person in order to avoid a hazard.
- Only an authorized repair person should disassemble, repair, or modify the appliance.
- Do not touch the power plug with wet hands.
- Do not place the power cord under rugs, carpeting or mats.
- Do not install and use broken parts.
- Do not continue to use the product if it is visibly damaged.
- Read the maintenance manual carefully before disassembling the machine.

Installation

- Do not install the appliance on an uneven or inclined surface.
- Do not install the appliance in an area exposed to direct sunlight or near heat-generating equipment.
- Do not install the product in a place where combustible gas may leak or industrial oil or metallic particulates are present.
- Do not allow the appliance to push against the power cord or plug.
- Do not bend the power cable excessively or place a heavy object on top of it.
- Do not extend the length of the power cable or alter it.
- Do not use several devices on a multi-socket extension outlet.
- Make the connection securely so that screw in terminals may not be loosened when the cable is pulled.
- Make sure that the power cable cannot be pulled out or damaged during operation.
- When unplugging the power cord, always pull it by the plug.

- Unplug the appliance during thunder or lightning storms or when not in use for a long time.

Operation

- If the appliance is immersed in water, stop using it and contact an LG Electronics Customer Information Center.
- If there is a gas leakage (isobutane, propane, LNG, etc.), do not touch the appliance or power plug and ventilate the area immediately.
- If you detect any abnormal noise, odor or smoke, unplug the appliance immediately and contact an LG Electronics Customer Information Center.
- Do not clean the appliance with brushes, cloths or sponges which are abrasive or made of metal.
- Do not use or store fire, combustibles (ether, benzene, alcohol, drugs, propane, butane, combustible spray, insecticide, air freshener, cosmetics, etc.) or flammable materials (candles, lamps, etc.) near the product.
- Do not allow animals or pets to chew on the power cord.
- Do not move the appliance when it is in operation.
- Do not hit the appliance.
- Do not insert hands or metal objects into the air inlet or outlet.
- Do not put flammables into the appliance.
- Do not move or operate the appliance while its cover is open.
- Do not allow children to climb on or play with the appliance.
- Do not place anything on top of the appliance.
- Be careful not to let body parts get caught in the product when removing product components and/or reassembling them.

UVnano Function

NOTE

- UVnano is a compound word of UV (ultraviolet rays) and nanometer (length unit).
- This product uses UVnano LED. Do not disconnect or replace the UVnano LED arbitrarily. LEDs must be replaced only by LG-approved service providers.
- Harmful UVnano radiation may leak if the device is used in an unintended way or if the wires are damaged. UVnano radiation, even in very small amounts, can harm the eyes and skin.
- The UVnano LED is not a part that needs cleaning, so do not clean the UVnano LED or parts with the UV hazard label separately.
- If the UVnano LED is damaged, do not operate it.
- This appliance contains a UV emitter. Do not stare at the light source.

Maintenance

- Dispose of the packing materials (vinyl, styrofoam, etc.) to keep them out of reach of children.
- Take care not to injure or pinch yourself when you detach and reattach parts of the appliance.
- Turn off and unplug the appliance before cleaning it or replacing the filter.

CAUTION INSTRUCTIONS

CAUTION

- To reduce the risk of minor injury to persons, malfunction, or damage to the product or property when using this product, follow basic precautions, including the following:

Installation

- Do not tilt the appliance to pull or push it when transporting.
- Do not install the appliance in a vehicle, RV, or marine vessel.
- Do not place the appliance near a TV or stereo equipment.
- Do not place the appliance under bright light.
- The appliance must be installed in accordance with national wiring regulations.
- When moving or storing the appliance, wrap the power cord around the base of the appliance to prevent personal injury, damage to the cord or damage to floors.
- Do not place the appliance near curtains.
- When assembling the table or the table top, do not let other objects come between them.

Operation

- Do not use the product for removal of toxic gas such as carbon monoxide.
- Do not use the product for ventilation purposes.
- Do not use the appliance for a long time in a region with unstable voltage.
- Do not place obstacles around the air inlet or outlet.
- For safe use of the appliance, children or others with reduced mental capabilities need to be closely monitored by a person who is responsible for their safety.
- Do not use the product for special purposes such as preserving plants, precision instruments, artworks, etc.

- Do not operate the appliance with wet hands.
- Do not let the moisture from a humidifier directly touch the appliance.
- Do not use the appliance while it is not in an upright position.
- Do not use the appliance near objects vulnerable to heat.
- Do not use detergents, cosmetics, chemicals, air fresheners, or disinfectants in the appliance.
- Do not touch any internal parts while the unit is operating or immediately after operation.
- Use the filter only for its intended purpose.
- The Deodorization filter and Dust collection filter are assembled together. Do not try to detach them from each other.
- Do not insert any objects into the Air outlet.
- Do not place magnets or metallic objects on top of the wireless charging unit of the product.
- Do not place a hot object on the product.
- Do not place a heavy object on the product. (Recommended gross weight: 2kg or less)

Maintenance

- Do not use strong detergents or solvents to clean the appliance. Use a soft cloth to clean.
- Do not clean the appliance with an alkaline detergent.
- Do not wipe the appliance surface using sulfuric acid, hydrochloric acid or organic solvents (thinner, kerosene etc.) or attach a sticker on the appliance.
- Do not allow water inside the appliance.
- Do not wash the filter with water.
- Be careful not to damage the ultra-fine filter when cleaning it with a vacuum cleaner.

Used Appliances

CAUTION

- Used appliances must be rendered unusable prior to disposal so that they no longer present a risk. To achieve this, disconnect from the mains supply and remove the power supply cable.
-

For the protection of the environment, used appliances must be disposed of properly.

- The appliance must not be disposed of along with normal domestic waste.
- Safely dispose all materials in accordance with federal/state/local laws or ordinances.

OPERATION

- The exterior or components of the product may vary depending on the model.

Product Overviews

Front

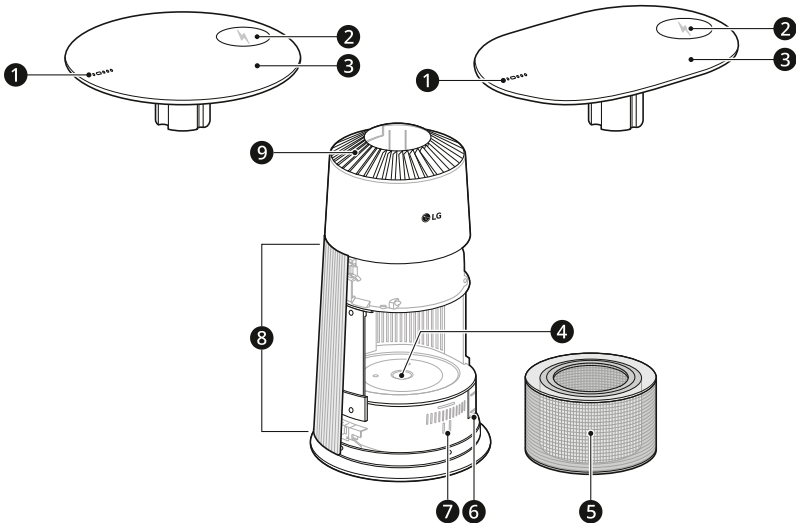

1 Status Panel

- Use it to check the settings of the appliance and the air quality.

2 Wireless Charging Unit

- Use it to charge a smart device enabling wireless charging.

3 Table Top

- This table top can be separated and replaced.

4 UVnano LED

- Remove the harmful bacteria at internal fan of the air purifier.

5 Filter

- Minimizes allergens, fine particulates, possible sources of sick house syndrome, smog, and other odors.

6 PM1.0 Sensor

- Detects the dust concentration levels.

7 Smart Diagnosis

- If the product malfunctions, use **Smart Diagnosis** to check the product status.

8 Air Inlet (Cover)

- Air is sucked into the air purifier through the air inlet.
- The front and rear covers can be removed separately.

9 Air Outlet

- Purified air from the filter is emitted.

Table

- It is bottom side of the table.

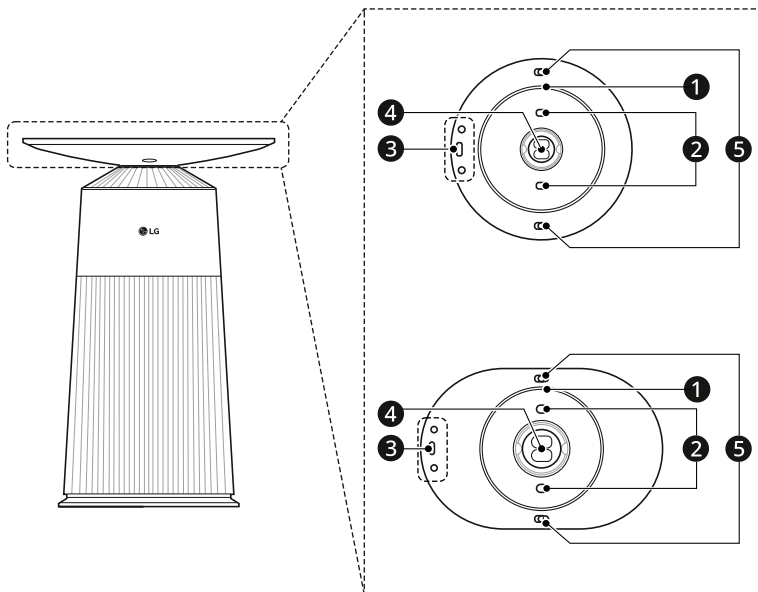

① Mood Light

- Use it to adjust the brightness of mood light.

② Table Base Separation Button

- The table can be separated by pressing the buttons on both sides at the same time.

③ Control Panel

- Use it to set the product functions (Standby On/Off, Speed, Mood light, etc.).

④ Table Joint

- This is the part where the main body and the table are combined.

⑤ Table Top Fixing/Separation Device

- Use it to fix or separate the table top after assembly.

NOTE

- The table and the table top (circle type/track type) can be purchased from a nearby LG Electronics Customer Information Center or visit the website (www.lg.com).

Filter

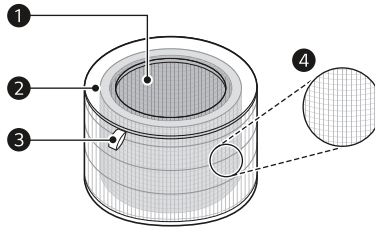

① Deodorization Filter

- This filter removes even smog-causing substances (SO_2 , NO_2), sick house syndrome-causing substances (toluene, formaldehyde), and household odors (ammonia, acetic acid, acetaldehyde).

② Dust collection filter

- Minimizes PM1.0 and cigarette smoke from the air.

③ Filter handle

- It is used to put in or pull out the filter.
- The side with the handle should face upwards.

④ Ultra-Fine Filter

- The Ultra-Fine Filter is coupled to the exterior of the filter and primarily removes household dust with large particles from the air.

⚠ CAUTION

- Do not forcefully separate filters, as the filters are coupled.
 - Do not throw the filters or use them for other purposes.
-

Components



①

- ① Owner's Manual

Preparation before Operation

Assembling the Product

Unpack the appliance and remove all packing tape and filter vinyl before using the appliance.

- 1 Remove the main body and the table from the box and remove the protective vinyl.
- 2 Prepare the main body and the table as shown in the figure below.
 - The side with the **LG logo** is the front of the product.
 - Based on the top side of the table, on the left side from the **LG logo** is the status panel(①) and on the right side from the **LG logo** is the wireless charging unit(②).

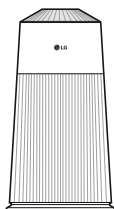

Front

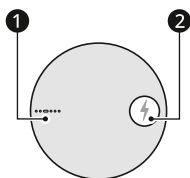

Top side of the table

- 3 Assemble the table to the main body according to the direction.

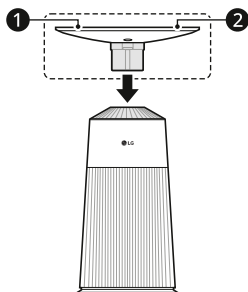

- ① Status panel
- ② Wireless charging unit

⚠ CAUTION

- Assemble the table to the main body until a clicking sound is heard.
 - If it is not assembled properly, the product won't operate.
- Pay attention to the assembly directions when assembling the table to the main body.
 - Failure to do so may cause malfunction or product failure.
- If power is connected to the main body without assembling the table, the product won't operate.

NOTE

- Assemble the track type in the same way as the circle type.

Removing the Protective Vinyl from the Filter

- 1 Take the product out of the box, and remove the vinyl or the fixing tape attached to the product.
- 2 Based on the front of the product, hold and gently pull both sides of the air inlet (cover) to separate it.
 - The side with the **LG logo** at the center of the product is the front of the product.

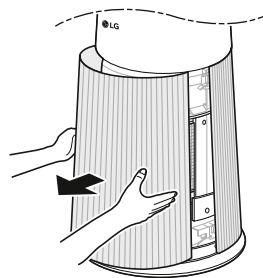

- 3 Remove the filter and detach the vinyl.

14 OPERATION

- When removing the packaged filter, separate it from the protective vinyl.

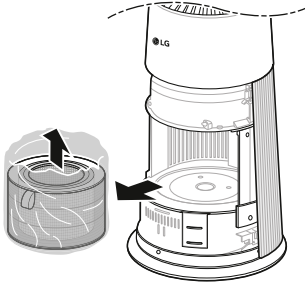

- When installing the filter, pay attention to the direction of the filter.
 - Failure to do so may cause malfunction or product failure.
 - The part with the filter handle is the top.

Installation Location Requirements

Install the product at least 1m from walls.

- If there is not enough room for air suction, the air purification performance may degrade.

4 Install the filter into the product.

- Make sure that the side with the filter handle is facing upward.

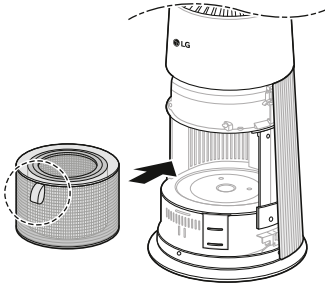

5 Insert the fixing part on both sides at the bottom of the cover into the fixing groove in the bottom of the product, and then close the cover.

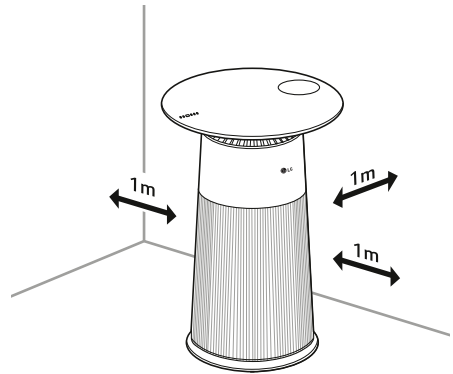
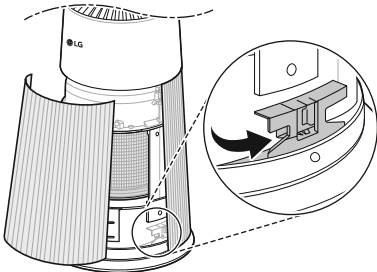

Circle Type

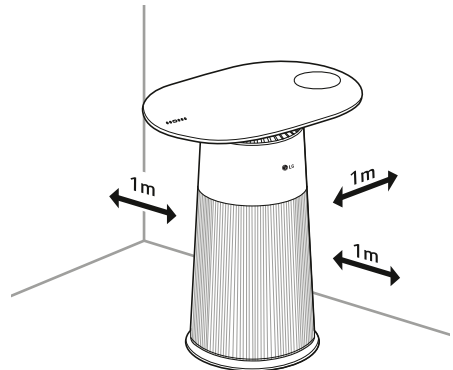

Track Type

⚠ CAUTION

- Be sure to remove the protective vinyl from the filter before using the product.

- The performance of the product may differ depending on the operating environment (considering factors such as temperature and humidity).
 - At humidity levels of between 40 % – 70 %, the product's guaranteed performance standards can be achieved.
- Do not install the product in a place exposed to direct sunlight or near lighting fixtures with strong light.
 - This may cause product discoloration.

Transportation Requirements

- When moving or storing the product, make sure that the power cord does not touch the floor by wrapping the power cord around the lower part of the product.
 - Otherwise, it may damage the power plug or scratch the floor.
- When carrying and moving the product
 - Hold the bottom of both sides of the product table and move it safely.

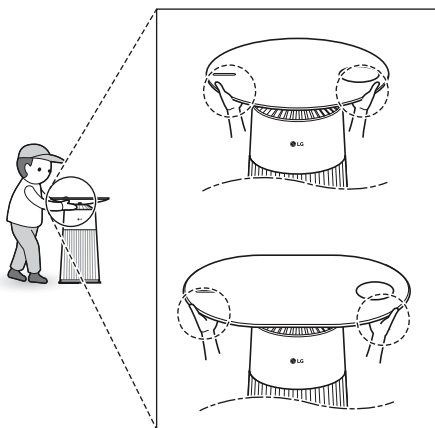

⚠ CAUTION

- Move the product after checking that the table is properly fixed.
- Do not hold the outside cover of the product in order to move the product. The cover may open accidentally, causing the product to drop.

- When holding the bottom of the table, be careful not to press the **Table Base Separation** button. Doing so may separate the table from the main body and cause it to fall.
 - If the product is dropped, it may cause injury or product failure.

Replacing the Table and the Table Top

Replacing the Table

Remove the packaging vinyl from the table before using it.

- 1 Separate the table by pulling it up while pressing the **Table Base Separation** button on both sides at the bottom of the table at the same time.

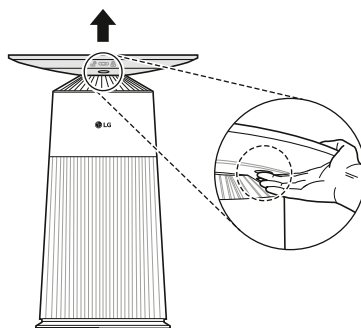

- 2 Assemble a new table into the main body.
 - Read "Assembling the Product".

⚠ CAUTION

- When separating or assembling the table, be careful not to let water or foreign objects enter into the table joint.
- Do not separate the table while operating the product.
- Use the **Table Base Separation** button only for replacing the table.

⚠ CAUTION

- Using the button incorrectly may cause injury or product failure.

Replacing the Table Top

Remove the packaging vinyl from the table top before using it.

- 1 With the table separated, disassemble the **Table Top Fixing/Separation** device from both sides of the table as shown in the figure below.

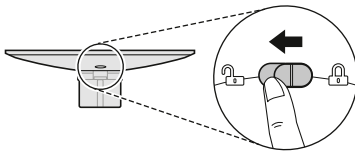

- 2 As shown in the figure below, first lift the joint unit of the wireless charging unit up to disassemble it, and then lift up the table top to separate it.

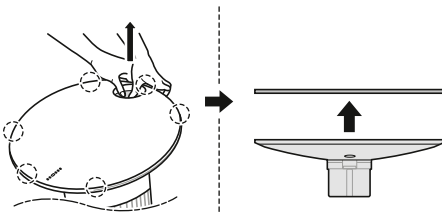

NOTE

- Disassemble 6 joint units for the circle type and 10 joint units for the track type.

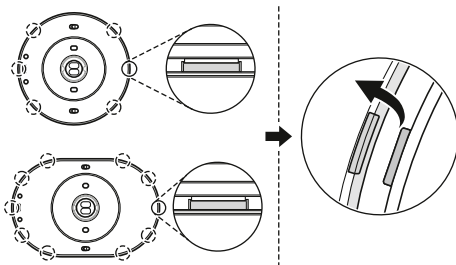

- For the track type, first lift the joint unit of the wireless charging unit up to disassemble it, and then lift up the table top to separate it.

- 3 Place a new table top at the position of the wireless charging unit correctly, assemble the joint unit and fix the **Table Top Fixing/Separation** device as shown in the figure below.

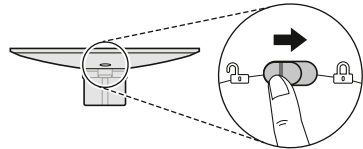

NOTE

- It applies in cases where separate accessories are purchased.
- When fixing the table top, close the fixing device until a click is heard.

⚠ CAUTION

- Be careful not to pinch your fingers or nails when separating or assembling the table.
 - Failure to do so may cause injury.
- When separating the table, be careful not to let the table bump into any part of your body (face, chest, etc.).
- Use the **Table Top Fixing/Separation** device only for replacing the table top.
 - Using the device incorrectly may cause injury or product failure.

Examining Features



Controlling the Air Purifier

Status Panel

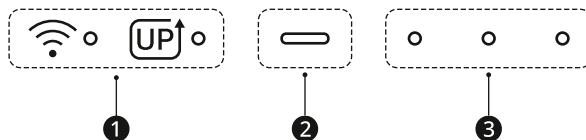
(Top side of the table)



1 Add-on Display





Icon	Description
	It is displayed when Wi-Fi connection is established, enabling remote control.
	It is displayed when a new function that can be upgraded becomes available.

2 Air Quality Light

- You can check the overall air quality through the air quality light.
- In Sleep mode, the air quality light is turned off.

3 Speed Light

- Indicates the speed set among Auto, Low, Middle, High and Sleep.

Speed	Display	Description
Auto		3 LEDs circulating
Low		1 LED ON
Middle		2 LEDs ON
High		3 LEDs ON
Sleep		1 LED ON (50% of brightness of Low)

Control Panel

(Bottom side of the table)

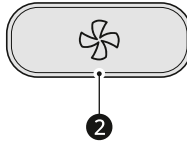

1 Standby On/Off Button

- Use it to turn the product on or off.

2 Speed Button

- Use it to set the fan speed.

3 Mood Light Button

- Use it to set the brightness of mood Light.

NOTE

- You can use additional functions by pressing the buttons on the control panel for 3 seconds.

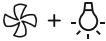
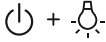
Long press (more than 3 seconds)	Extra Functions
	Wi-Fi connection (Remote operation)
	Smart Diagnosis
	Cancel Filter Replacement Alert

Operating the Air Purifier

Things to Know before Operation

- The control panel is located below the table.

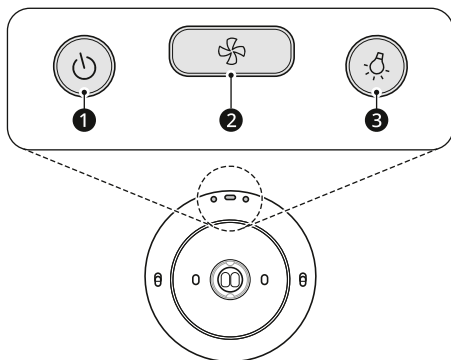

① Standby On/Off Button

② Speed Button

③ Mood Light Button

Standby On/Off

Turns the product on and off.

- Press the **Standby On/Off** button to start operation.

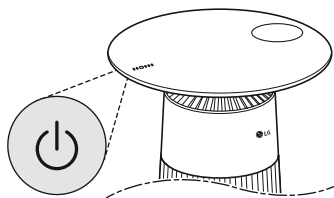

NOTE

- If you stop operation and then resume, it will start cleaning with the mode you last selected.
- If the product is unplugged or a power failure occurs during operation, the most recently used mode (speed, light) will be memorized.

Adjusting the Fan Speed

You can adjust the fan speed from the air purifier.

- When you press the **Speed** button during product operation, the speed changes in the order of Auto → Low → Middle → High → Sleep.

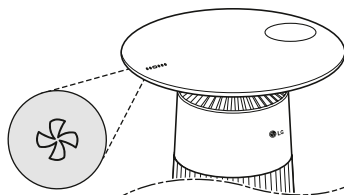

NOTE

- The higher the fan speed, the higher the purification rate in the operating space.
- When Auto is set, the speed will be controlled automatically according to the contamination level of the indoor air.
- When Sleep is set, the air quality light will be turned off.

Using the Extra Functions

Setting the Brightness of Mood Light

You can adjust the mood light brightness.

- When you press the **Mood Light** button during product operation, the brightness of Light under the table base changes in the order of **ON** → **ON at Middle brightness** → **OFF**.

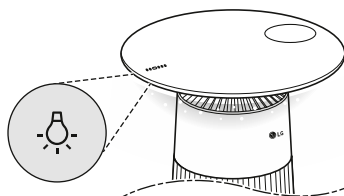

NOTE

- OFF is set as the initial step in mood light.
- Mood light brightness can be controlled also when **Sleep** is set for the fan speed and operation has stopped.

Using UVnano

The function sterilizes the fan inside the air purifier to circulate cleaner air.

- Change the UVnano setting with the **LG ThinQ** Application.

NOTE

- UVnano is a compound word of "UV" LEDs that reduce harmful bacteria and "nanometers", as in the ultraviolet wavelength unit.
- The UV LED is not a part that needs cleaning, so do not clean the UV LED or parts displaying the UV hazard label separately.
- If the UV LED is damaged, do not operate it.
- To clean the product or replace the filter, unplug the product.
- The UVnano function is enabled by default when using the product for the first time.

Charging a Smart Device

Placing a smart device supporting wireless charging on the charging area with the power connected to the product, will see charging begin.

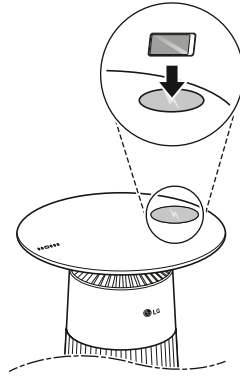

- Place the smart device in the center of the wireless charging unit.
 - If the smart device wireless charging unit leaves the center of the wireless charging unit, it may not be charged smoothly.
 - The farther away from the center the smart device is, charging will be less efficient, or may temporarily stop repeatedly.

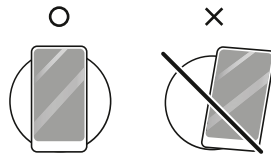

⚠ CAUTION

- If there is a coin or other metallic object between the wireless charging unit and the smart device, be sure to remove it before using the unit.
 - Wireless charging may stop due to metallic objects.
 - Metallic substances may become hot during the charging process, resulting in low-temperature burns.

NOTE

- Each smart device has different wireless charging characteristics, so check the contents

regarding wireless charging in the smart device's manual before using wireless charging.

- If the temperature of the wireless charging unit is too high during charging, charging will stop.
 - In order to protect the smart device, charging stops when the temperature reaches a preset temperature, and when it falls under the set temperature, the charging function will resume.
 - Charging may fail because of a smart device's protective case.
 - Charging may not be possible due to metal or a ring holder.
 - Depending on the thickness of the protective case, charging may be delayed or interrupted.
 - When using a wallet/card case, charging may be delayed or interrupted because of a card or the thickness of the case.
 - Placing magnetic materials, such as a credit card, near the wireless charging area or the charging area may damage the information contained therein.
 - When you place a smart device in the charging area, charging will begin 3 to 5 seconds later.
 - Charging time may vary depending on the smart device manufacturer.
 - If charging does not begin 3 to 5 seconds later, lift the smart device and change its position.
 - Using wireless charging in an area where the network signal strength is weak may deteriorate the smartphone's network performance.
 - If you connect a wired charger to a smart device that is currently being charged wirelessly, the wireless charging function will be disabled.
-

Overall Air Quality

Understanding Overall Air Quality

The overall air quality is calculated based on the concentration of particulates and is categorized in 4 levels based on the level of pollution in the air. (Green, Yellow, Orange, and Red)

Color	Overall air quality	Concentration of PM ($\mu\text{g}/\text{m}^3$)		
	State	PM10	PM2.5	PM1.0
Red	Poor	255 or more	56 or more	56 or more
Orange	Unhealthy	155 ~ 254	36 ~ 55	36 ~ 55
Yellow	Moderate	55 ~ 154	13 ~ 35	13 ~ 35
Green	Good	54 or less	12 or less	12 or less

NOTE

- Overall air quality is determined based on the concentration of particulate matter (PM).
- The PM concentration measurement was tested using LG Electronics' standard test materials.
- Differences in PM concentration values may be the result of different methods of measuring or differences in the actual PM concentration levels.
 - If the PM concentration is high, there may be a larger difference between the displayed concentration and the actual concentration.

SMART FUNCTIONS

LG ThinQ Application

The **LG ThinQ** application allows you to communicate with the appliance using a smartphone.

LG ThinQ Application Features

Smart Diagnosis

If you experience a problem while using the appliance, this **Smart Diagnosis** feature will help you diagnose the problem.

Settings

Allows you to set various options on the appliance and in the application.

NOTE

- If you change your wireless router, internet service provider, or password, delete the connected appliance from the **LG ThinQ** application and connect it again.
- The application is subject to change for appliance improvement purposes without notice to users.
- Functions may vary by model.

Before Using LG ThinQ Application

This feature is only available on models with Wi-Fi function.

- 1 Check the distance between the appliance and the wireless router (Wi-Fi network).
 - If the distance between the appliance and the wireless router is too far, the signal strength becomes weak. It may take a long time to connect or installation may fail.

- 2 Turn off the Mobile data or Cellular Data on your smartphone.

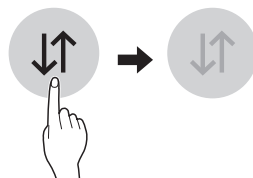

- 3 Connect your smartphone to the wireless router.

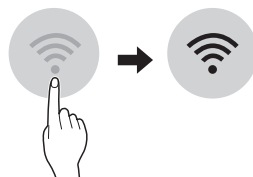

NOTE

- To verify the Wi-Fi connection, check that the Wi-Fi  icon on the status panel is lit.
- **The appliance supports 2.4 GHz Wi-Fi networks only.** To check your network frequency, contact your Internet service provider or refer to your wireless router manual.
- **LG ThinQ** is not responsible for any network connection problems or any faults, malfunctions, or errors caused by network connection.
- If the appliance is having trouble connecting to the Wi-Fi network, it may be too far from the router. Purchase a Wi-Fi repeater (range extender) to improve the Wi-Fi signal strength.
- The Wi-Fi connection may not connect or may be interrupted because of the home network environment.
- The network connection may not work properly depending on the Internet service provider.
- The surrounding wireless environment can make the wireless network service run slowly.

NOTE

- If the appliance cannot be connected due to problems with the wireless signal transmission, unplug the appliance and wait about a minute before trying it again.
 - If the firewall on your wireless router is enabled, disable the firewall or add an exception to it.
 - The wireless network name (SSID) should be a combination of English letters and numbers. (Do not use special characters.)
 - Smartphone user interface (UI) may vary depending on the mobile operating system (OS) and the manufacturer.
 - If the security protocol of the router is set to WEP, the network setup may fail. Change the security protocol (WPA2 is recommended) and connect the product again.
-

Installing the LG ThinQ Application

Search for the **LG ThinQ** application from the Google Play Store or Apple App Store on a smartphone. Follow instructions to download and install the application.

Open Source Software Notice Information

To obtain the source code that is contained in this product, under GPL, LGPL, MPL, and other open source licenses that have the obligation to disclose source code, and to access all referred license terms, copyright notices and other relevant documents, please visit <https://opensource.lge.com>.

LG Electronics will also provide open source code to you on CD-ROM for a charge covering the cost of performing such distribution (such as the cost of media, shipping, and handling) upon email request to opensource@lge.com.

This offer is valid to anyone in receipt of this information for a period of three years after our last shipment of this product.

Smart Diagnosis

Use this feature to help you diagnose and solve problems with your appliance.

NOTE

- For reasons not attributable to LGE's negligence, the service may not operate due to external factors such as, but not limited to, Wi-Fi unavailability, Wi-Fi disconnection, local app store policy, or app unavailability.
 - The feature may be subject to change without prior notice and may have a different form depending on where you are located.
-

Using LG ThinQ to Diagnose Issues

If you experience a problem with your Wi-Fi equipped appliance, it can transmit troubleshooting data to a smartphone using the **LG ThinQ** application.

- Launch the **LG ThinQ** application and select the **Smart Diagnosis** feature in the menu. Follow the instructions provided in the **LG ThinQ** application.

Using Audible Diagnosis to Diagnose Issues

Follow the instructions below to use the audible diagnosis method.

- Launch the **LG ThinQ** application and select the **Smart Diagnosis** feature in the menu. Follow the instructions for audible diagnosis provided in the **LG ThinQ** application.

- 1 Press and hold the **Speed** and **Mood Light** button for 3 seconds to execute the **Smart Diagnosis** function.

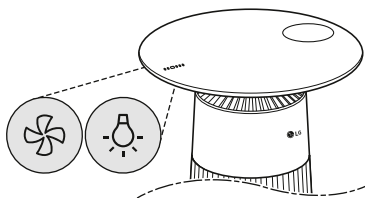

- 2 Place your smartphone near the product.
 - Make sure the microphone of the smartphone faces the front of the product.

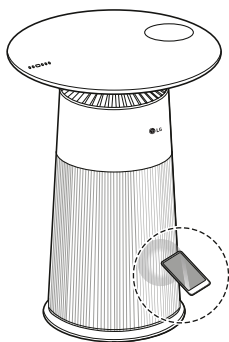

- 3 When data transmission is complete, the **Smart Diagnosis** result will be displayed on the **LG ThinQ** Application.

NOTE

- For accurate diagnosis, do not move the smartphone away from the product until the beeping stops.
 - Keep quiet around the product during **Smart Diagnosis**.
-

MAINTENANCE

Maintaining the Product

Scheduled maintenance

⚠ WARNING

- Be sure to stop the appliance operation and remove the power plug from the outlet before cleaning and replacing the filter.
- Do not spray water directly on the appliance.

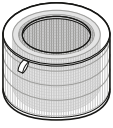
Component	Cleaning frequency	Replacement frequency
 <p>Filter</p>	<p>Ultra-fine filter Clean filter as needed</p>	1 year

NOTE

- The cleaning frequency may vary depending on the operating hours and environment of the appliance.
- If you do not clean the product according to the cleaning frequency, you may experience a bad odor and poor performance.
- The filter must be replaced at the end of its lifespan, and the cost of replacement filters is not covered under the warranty. To purchase new filters, contact an LG Electronics Customer Information Center or visit the website at www.lg.com.
- You can also have the filter cleaned or replaced by the Service Center. You will be charged a nominal fee for filter cleaning and replacement services.
- The upper and lower parts of the filter are made of paper instead of plastic. Repeated removal of the filter may cause scratches on the top and bottom of the filter.

- Even if there are scratches on the top and bottom of the filter, there is no problem in use.

Alerts on the Status Panel

Alert	Description	Measures
	3 LEDs blinking at the same time	Replace the filter.

NOTE

- Filter replacement alerts appear based on the maximum usage time, taking into account the operating hours of the appliance. The replacement frequency is determined by the operating hours and environment.

Cleaning the Exterior

- 1 Remove dust from the air inlet using a vacuum cleaner.
- 2 Wipe the exterior of the table top with a soft cloth.

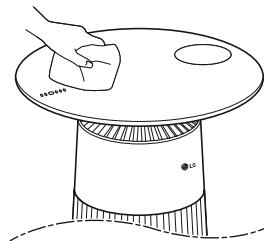

⚠ CAUTION

- Do not wipe the appliance with an alkaline detergent.

- Never use sulphuric acid, hydrochloric acid or organic solvent (e.g., thinner, kerosene and acetone) to wipe the appliance exterior, or affix labels on the exterior. Doing so may damage the product surface.
- Care should be exercised to prevent flowing of water into the product.
- If the product is stained by soapy water, cosmetics, chemicals, air fresheners, disinfectants, etc., wipe the substance off immediately with a soft cloth or wet wipe.
- Do not let a sharp object such as a key or a knife come into direct contact with the surface of the product.
 - Failure to do so may result in damage to the product's surface.
- Do not let ballpoint pens, crayons, colored pencils, etc., come into direct contact with the surface of the product.
 - Failure to do so may result in staining or damage to the surface of the product.

- The side with the **LG logo** at the center of the product is the front of the product.

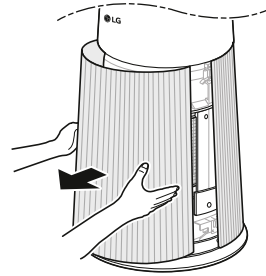

- 2 Push the sensor cover up.

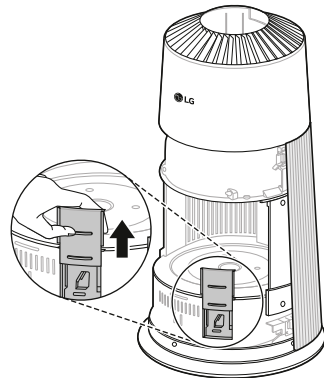

- 3 Clean the lens with a cotton swab soaked with water and clean it again with a dry cotton swab.

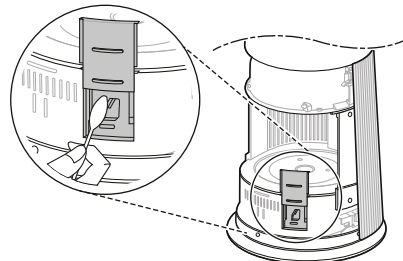

NOTE

- Refer to the following contents for cleaning the table top.
 - If the product is dusty or stained, wipe with a clean microfiber cloth or wet wipe for cleaning.
 - If the product is stained through being touched by hands stained with cosmetics, wipe the substance off with a microfiber cloth moistened with a face wash (foam cleanser, etc.).

Cleaning the Particles Sensor

The PM1.0 sensor is the device detecting fine dust and large dust contamination levels, so it is recommended to clean the lens periodically, at least once every 2 months.

- 1 Based on the front of the product, hold and gently pull both sides of the air inlet (cover) to separate it.

4 Close the sensor cover.

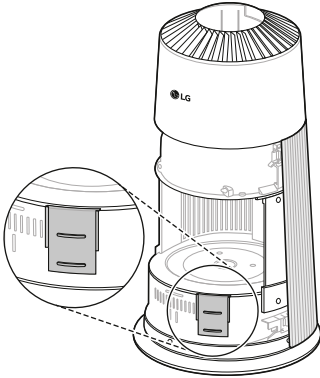

NOTE

- Do not wipe the sensor with any substances other than water. It may cause a appliance to malfunction.
- When opening or closing the sensor cover, a sound may be heard as a result of friction.

Cleaning the Filters

- 1 Separate the front and rear covers from the product.
 - Based on the front of the product with the **LG logo**, hold and gently pull both sides of the cover on top of the air inlet (cover) to separate it.

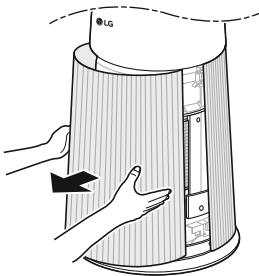

- 2 Using a vacuum cleaner or soft brush, remove any dust from the ultra-fine filter surrounding the filter.

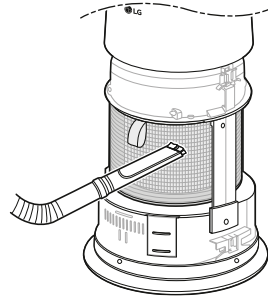

CAUTION

- Do not clean the filter with water. The service life of the filter may be reduced.
- Be careful not to damage the ultra-fine filter when using a vacuum cleaner.
- Take caution because there is a risk of tearing or loss when separating or assembling the ultra-fine filter.
- Be careful as the filter may be damaged if it is covered with liquid.

Replacing the Filters

- 1 Remove the cover of the product, and replace the filter.
 - To avoid polluting the surroundings when replacing the filter, place newspaper on the floor before you remove the filter.

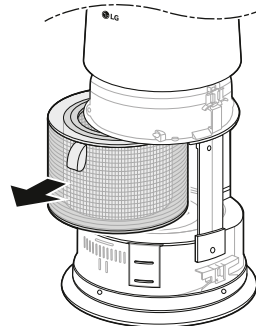

- 2 When you finish replacing the filter, turn off the Filter Replacement Notification.

Turning off Filter Replacement Notification

Press and hold the **Standby On/Off** and **Mood Light** buttons on the control panel for 3 seconds.

- Filter Replacement Notification on the Status Panel is turned off and the time for Filter Replacement Notification is initialized.

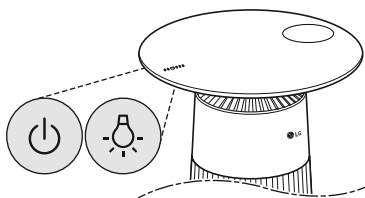

NOTE

- A notification is displayed when the filter needs to be replaced.
- Use when replacing with a new filter.

Replacing the Ultra-Fine Filter

Check the Velcro of the ultra-fine filter and replace the ultra-fine filter by separating it slowly.

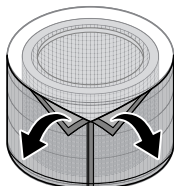

Storage

Storing the Product

If the product will not be used for a long period of time, store it in a dry and shaded place.

- 1 Operate the product for one hour or more on a fine day.
 - This removes moisture and prevents molds from building-up inside the product.

- 2 Turn off the power and unplug it from the electrical outlet.
 - Wind the power cord around the bottom of the appliance.
- 3 Package the appliance to prevent the dust or foreign substance from entering the appliance. Store the packaged product in a dry shaded place.

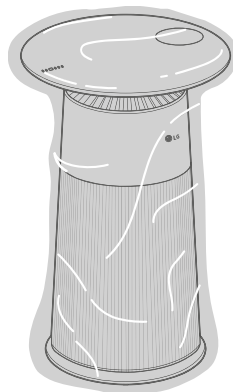

CAUTION

- Do not store the appliance at a humid place or at a place exposed to the direct sunlight. Otherwise the appliance may be deformed, malfunction or generate odor.

TROUBLESHOOTING

Before Calling for Service

Please check the following before calling for service. If the problem persists, contact your local service center.

Operation

Symptoms	Possible Cause & Solution
The product does not power on.	Is the power plug disconnected? <ul style="list-style-type: none"> Connect it to an outlet correctly.
	Did the electricity get cut off? <ul style="list-style-type: none"> Check the power to other products in the house.
	Are the main body of the product and the table assembled properly? <ul style="list-style-type: none"> Assemble the main body of the product and the table properly.
A noise occurs and the fan speed is low.	Has dust accumulated in the ultra-fine filter? <ul style="list-style-type: none"> Clean the ultra-fine filter.
	Has dust accumulated in the filter? <ul style="list-style-type: none"> Replace the filter.
Air purification is not done properly.	Is the indoor pollution severe? <ul style="list-style-type: none"> Ventilate indoors before using the product.
	Has dust accumulated in the ultra-fine filter? <ul style="list-style-type: none"> Clean the ultra-fine filter.
	Has dust accumulated in the filter? <ul style="list-style-type: none"> Replace the filter.
	Are you using it in a place that is too spacious or too open? <ul style="list-style-type: none"> Use a product that suits the size of the room. Avoid well-ventilated places such as doors, windows, etc.
	Is there an obstacle nearby? <ul style="list-style-type: none"> Remove any nearby obstacles before operating the product.
	Is the product installed in a corner? <ul style="list-style-type: none"> Move the product and reinstall it.
Wireless charging is not available.	Did you place the smart device at the center of the wireless charging unit? <ul style="list-style-type: none"> If the smart device leaves the center of the wireless charging unit, it will not be charged.

Symptoms	Possible Cause & Solution
Wireless charging is not available.	<p>Is the smart device fitted with a protective case?</p> <ul style="list-style-type: none"> Depending on the thickness of the protective case, charging may be delayed or interrupted. Charging may not be possible due to metal or a ring holder. When using a wallet type/card type case, charging may be delayed or interrupted because of a card or the thickness of the case.
The air quality light is continuously red.	<p>Does the color not change even if it is moved to a clean room?</p> <ul style="list-style-type: none"> If the amount of odor is more than the capacity of the product, the display may not change. Remove the power plug from the outlet and reconnect after 1 minute.
	<p>Did you use a spray near the product?</p> <ul style="list-style-type: none"> Do not use a spray near the product.

Odor

Symptoms	Possible Cause & Solution
A strange odor comes out of the air outlet as well as the filter.	<p>Did you purchase the product recently?</p> <ul style="list-style-type: none"> This is the odor of activated charcoal, and is not harmful. This is similar to the odor you may experience in a brand new car. It will go away within a day following use.
	<p>Is the product used in a place with a lot of smoke or odors?</p> <ul style="list-style-type: none"> If the air purifier is operated after an air freshener, diffuser, or scented candle has been used, or interior work or wallpaper replacement have occurred, the filter may absorb and emit an odor. Ventilate the room first before using the product.
	<p>Does the filter have a bad smell?</p> <ul style="list-style-type: none"> The filter replacement cycle may vary depending on the usage environment. If there is an odor, replace the filter with a new one.
	<p>Is it in an environment in which food is prepared?</p> <ul style="list-style-type: none"> If you use the product for a long period of time where you cook or broil fish/meat, the filter lifespan may be significantly decreased. If possible, open a window for ventilation while cooking, and use the product to remove any odors left following ventilation.
	<p>Is it a humid environment?</p> <ul style="list-style-type: none"> The filter may emit an odor if used in a humid environment. Dry the filter in sunlight before use.

LG ThinQ

Symptoms	Possible Cause & Solution
<p>The product and the smartphone cannot be connected through Wi-Fi.</p>	<p>Is the Wi-Fi password used to connect to the smartphone correct?</p> <ul style="list-style-type: none"> • Press the Settings button on your smartphone, and then find your Wi-Fi in the network list. Press and hold the button to select [Clear Network], and then proceed with product registration again from the beginning.
	<p>Is your smartphone using mobile data rather than Wi-Fi?</p> <ul style="list-style-type: none"> • In the smartphone's settings, turn off Mobile Data, turn on Wi-Fi, and then register the product.
	<p>Does the name (ID) of the wireless router contain special characters?</p> <ul style="list-style-type: none"> • Set the name (ID) of the wireless router as a combination of numbers and English letters. Wi-Fi connection may be difficult if you enter special characters.
	<p>Is the frequency of the wireless router not 2.4 GHz?</p> <ul style="list-style-type: none"> • When connecting the product via Wi-Fi, only a 2.4 GHz network can be used. Set the wireless router to 2.4 GHz and then connect. To check the frequency of your wireless router, contact your Internet carrier or router manufacturer.
	<p>Are the product and the wireless router too far apart?</p> <ul style="list-style-type: none"> • If the distance between the product and the wireless router is too great, the wireless signal may be weak, and the connection may not be smooth. Move the wireless router closer to the product.

APPENDIX

Information

APPLIANCE SPECIFICATIONS

- Appearance and specifications may vary without notice to improve the quality of the appliance.
- This product is not equipped with a gas sensor.

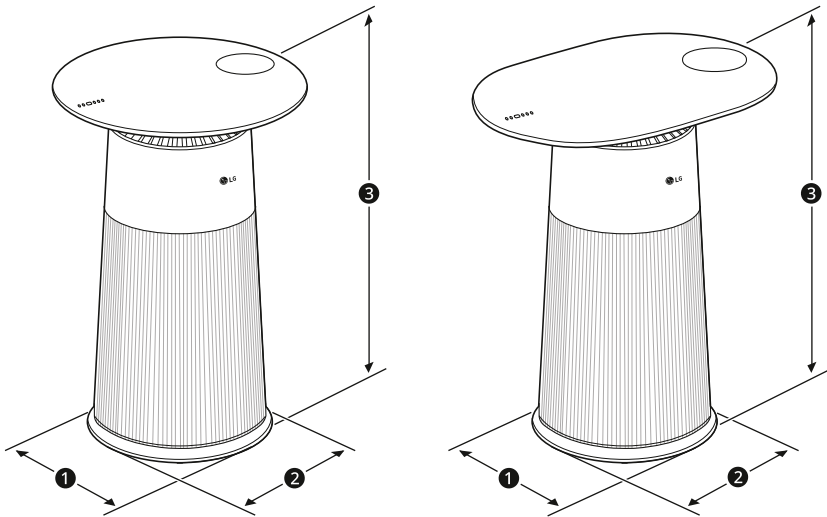

Name	AS20GP*K0
Power	AC 220 V - 240 V~, 50/60 Hz
Exterior Dimensions (1 x 2 x 3)	265 mm x 265 mm x 561 mm

Warranty

Warranty Information

- Warranty period of Product :
 - 1 year from the date of original retail purchase.
 - 10 Years on Inverter Motor only
(except for Wearable Air Purifier, Puricare Mini, 360° Air Purifier Hit)

LG Customer Information Centre

- For any Suggestion, Opinion & Complaints, Within UAE please Call 800 54 (LG), or please contact to our local dealer or log into www.lg.com.
- For any Suggestion, Opinion & Complaints, Out side UAE please contact to our local dealer or log into www.lg.com.

Importers

Country	Trade Name	Address
UAE	LG Electronics Gulf FZE	GF-Jebel Ali Main Warehouse, Jebel Ali Free Zone, P.O. Box: 61445 Dubai, UAE
	Al Yousuf Electronics	Al Yousuf Electronics AL YOUSUF ELECTRONICS LLC P.O.BOX NO 25 DUBAI, UAETEL: +971 4 295 7300 FAX: +971 4 295 7988
Saudi Arabia	LG Electronics Saudi Arabia LLC	2091 Jameel Square, Alandalus Dist. Mohammed Bin Abdulaziz Street, Jeddah, PO Box 10876, Zip code : 21443
Qatar	Video Home & Electronic Centre W.L.L	Video Home & Electronic Centre W.L.L, P.O. Box 4668, Doha, Qatar TEL: +974 4 401 1777 FAX: +974 4 476 1715
Oman	OmanGulf Enterprises LLC	PO Box 175, PC 117 Muscat, Sultanate of Oman TEL: +968 2 200 6300

Memo

