



ENGLISH

FRANÇAIS

ESPAÑOL

INSTALLATION MANUAL

# AIR CONDITIONER

Please read this installation manual completely before installing the product. Installation work must be performed in accordance with the national wiring standards by authorized personnel only.

Please retain this installation manual for future reference after reading it thoroughly.

Standard Inverter



MFL63260140  
Rev.05\_102725

[www.lghvac.com](http://www.lghvac.com)  
[www.lg.com](http://www.lg.com)

Copyright © 2024-2025 LG Electronics Inc. All Rights Reserved.

## TIPS FOR SAVING ENERGY

Here are some tips that will help you minimize the power consumption when you use the air conditioner.

You can use your air conditioner more efficiently by referring to the instructions below:

- Do not cool excessively indoors. This may be harmful for your health and may consume more electricity.
- Block sunlight with blinds or curtains while you are operating the air conditioner.
- Keep doors or windows closed tightly while you are operating the air conditioner.
- Adjust the direction of the air flow vertically or horizontally to circulate indoor air.
- Speed up the fan to cool or warm indoor air quickly, in a short period of time.
- Open windows regularly for ventilation as the indoor air quality may deteriorate if the air conditioner is used for many hours.
- Clean the air filter once every 2 weeks. Dust and impurities collected in the air filter may block the air flow or weaken the cooling / dehumidifying functions.

### For your records

Staple your receipt to this page in case you need it to prove the date of purchase or for warranty purposes.

Write the model number and the serial number here:

Model number : \_\_\_\_\_





Serial number : \_\_\_\_\_

You can find them on a label on the side of each unit.

Dealer's name : \_\_\_\_\_

Date of purchase : \_\_\_\_\_

# SAFETY INSTRUCTIONS

	Read the precautions in this manual carefully before operating the unit.
	This symbol indicates that the Operation Manual should be read carefully.
	This appliance is filled with flammable refrigerant.
	This symbol indicates that a service personnel should be handling this equipment with reference to the Installation Manual.

The following safety guidelines are intended to prevent unforeseen risks or damage from unsafe or incorrect operation of the appliance. The guidelines are separated into 'WARNING' and 'CAUTION' as described below.



This symbol is displayed to indicate matters and operations that can cause risk. Read the part with this symbol carefully and follow the instructions in order to avoid risk.



## WARNING

This indicates that the failure to follow the instructions can cause serious injury or death.



## CAUTION

This indicates that the failure to follow the instructions can cause the minor injury or damage to the product.

## WARNING

- Installation or repairs made by unqualified persons can result in hazards to you and others.
- Installation of all field wiring and components MUST conform with local building codes or, in the absence of local codes, with the National Electrical Code 70 and the National Building Construction and Safety Code or Canadian Electrical code and National Building Code of Canada.
- The information contained in the manual is intended for use by a qualified service technician familiar with safety procedures and equipped with the proper tools and test instruments.
- Failure to carefully read and follow all instructions in this manual can result in equipment malfunction, property damage, personal injury and/or death.

### Installation

- Always perform grounding.
  - Otherwise, it may cause electrical shock.
- Don't use a power cord, a plug or a loose socket which is damaged.
  - Otherwise, it may cause a fire or electrical shock.
- For installation of the product, always contact the service center or a professional installation agency.
  - Otherwise, it may cause a fire, electrical shock, explosion or injury.
- Securely attach the electrical part cover to the indoor unit and the service panel to the outdoor unit.
  - If the electrical part cover of the indoor unit and the service panel of the outdoor unit are not attached securely, it could result in a fire or electric shock due to dust, water, etc.
- Always install an air leakage breaker and a dedicated switching board.
  - No installation may cause a fire and electrical shock.

- Do not keep or use flammable gases or combustibles near the air conditioner.
  - Otherwise, it may cause a fire or the failure of product.
- Ensure that an installation frame of the outdoor unit is not damaged due to use for a long time.
  - It may cause injury or an accident.
- Do not disassemble or repair the product randomly.
  - It will cause a fire or electrical shock.
- Do not install the product at a place that there is concern of falling down.
  - Otherwise, it may result in personal injury.
- Use caution when unpacking and installing.
  - Sharp edges may cause injury.
- Use a vacuum pump or Inert (nitrogen) gas when doing leakage test or air purge. Do not compress air or Oxygen and Do not use Flammable gases. Otherwise, it may cause fire or explosion. There is the risk of death, injury, fire or explosion.
- Do not store or use flammable gas or combustibles near the unit.
  - There is risk of fire, explosion, and physical injury or death.

#### **For add on heat pumps with flammable refrigerants**

1. Instruction for installation of the critical-to-safety wiring connection of the leak detection sensor or leak detection system to the furnace assembly.
    - The wiring shall be not less than 18 AWG with a minimum insulation thickness of 1.58 mm or protected from damage. Critical-to-safety wiring is any field installed wiring necessary to fulfill the requirements of flammable refrigerant in the event of detection of a leak.
  2. Shall not be installed on furnaces with an inductive electrical greater than  $Le$ 
    - $Le = 5$  when breaking all phases of a three phase load
    - $Le = 2.5$  all others
  3. Detection of a leak shall turn on the indoor fan at the highest available speed or turn it on to not less minimum air flow rate (Consult furnace manufacturer.)
- Do not use means to accelerate the defrosting process or to clean, other than those recommended by the manufacturer.
  - The appliance shall be stored in a room without continuously operating ignition sources (for example: open flames, an operating gas appliance or an operating electric heater.)
  - Do not pierce or burn.
  - Be aware that refrigerants may not contain an odour.
  - The manufacturer may provide other suitable examples or may provide additional information about the refrigerant odour.
  - Pipe-work including piping material, pipe routing, and installation shall include protection from physical damage in operation and service, and be in compliance with national and local codes and standards, such as ASHRAE 15, ASHRAE 15.2, IAPMO Uniform Mechanical Code, ICC International Mechanical Code, or CSA B52. All field joints shall be accessible for inspection prior to being covered or enclosed.
  - An unventilated area where the appliance using flammable refrigerants is installed shall be so constructed that should any refrigerant leak, it will not stagnate so as to create a fire or explosion hazard.
  - Field-made refrigerant joints indoors shall be tightness tested. The test method shall have a sensitivity of 5 grams per year of refrigerant or better under a pressure of at least 0,25 times the maximum allowable pressure. No leak shall be detected;
  - If appliances connected via an air duct system to one or more rooms with A2L REFRIGERANTS are installed in a room with an area less than  $A_{min}$  as determined in standard, that room shall be without continuously operating open flames (e.g. an operating gas appliance) or other POTENTIAL IGNITION SOURCES (for e.g., an operating electric heater, hot surfaces). A flame-producing device may be installed in the same space if the device is provided with an effective flame arrest.

- After completion of field piping for split systems, the field pipework shall be pressure tested with an inert gas and then vacuum tested prior to refrigerant charging, according to the following requirements:
- The minimum test pressure for the low side of the system shall be the low side design pressure and the minimum test pressure for the high side of the system shall be the high side design pressure, unless the high side of the system, cannot be isolated from the low side of the system in which case the entire system shall be pressure tested to the low side design pressure.
- The test pressure after removal of pressure source shall be maintained for at least 1 h with no decrease of pressure indicated by the test gauge, with test gauge resolution not exceeding 5% of the test pressure.
- During the evacuation test, after achieving a vacuum level specified in the manual or less, the refrigeration system shall be isolated from the vacuum pump and the pressure shall not rise above 1500 microns within 10 min. The vacuum pressure level shall be specified in the manual, and shall be the lesser of 500 microns or the value required for compliance with national and local codes and standards, which may vary between residential, commercial, and industrial buildings.

#### **Qualification of workers**

The manual shall contain specific information about the required qualification of the working personnel for maintenance, service and repair operations.

Every working procedure that affects safety means shall only be carried out by qualified person by manufacturer.

Examples for such working procedures are:

- Breaking into the refrigerating circuit;
- Opening of sealed components;
- Opening of ventilated enclosures.

- Refrigerant tubing shall be protected or enclosed to avoid damage.
- Flexible refrigerant connectors (such as connecting lines between the indoor and outdoor unit) that may be displaced during normal operations shall be protected against mechanical damage.
- A brazed, welded, or mechanical connection shall be made before opening the valves to permit refrigerant to flow between the refrigerating system parts.
- Keep any required ventilation openings clear of obstruction.
- Mechanical connections (mechanical connectors or flared joints) shall be accessible for maintenance purposes
- Flexible pipe elements shall be protected against mechanical damage, excessive stress by torsion, or other forces. They should be checked for mechanical damage annually.
- Protection devices, piping and fittings shall be protected as far as possible against adverse environmental effects, for example, the danger of water collecting and freezing in relief pipes or the accumulation of dirt and debris.
- Precautions shall be taken to avoid excessive vibration or pulsation to refrigerating piping.
- Piping in refrigerating systems shall be so designed and installed to minimize the likelihood hydraulic shock damaging the system.
- Provision shall be made for expansion and contraction of long runs of piping.
- Steel pipes and components shall be protected against corrosion with a rustproof coating before applying any insulation.
- Auxiliary devices which can be potential ignition source shall not be installed in connecting ductwork. Examples of potential ignition sources are UV lights, electric heaters with a temperature exceeding 700 °C, pilot flames, brushed motors and similar devices.

## **Operation**

- Do not share the outlet with other appliances.
  - It will cause an electric shock or a fire due to heat generation.
- Do not use the damaged power cord.
  - Otherwise, it may cause a fire or electrical shock.
- Do not modify or extend the power cord randomly.
  - Otherwise, it may cause a fire or electrical shock.
- Take care so that the power cord may not be pulled during operation.
  - Otherwise, it may cause a fire or electrical shock.
- Unplug the unit if strange sounds, smell, or smoke comes from it.
  - Otherwise, it may cause electrical shock or a fire.
- Keep the flames away.
  - Otherwise, it may cause a fire.
- Take the power plug out if necessary, holding the head of the plug and do not touch it with wet hands.
  - Otherwise, it may cause a fire or electrical shock.
- Do not use the power cord near the heating tools.
  - Otherwise, it may cause a fire and electrical shock.
- Do not open the suction inlet of the indoor/outdoor unit during operation.
  - Otherwise, it may electrical shock and failure.
- Do not allow water to run into electrical parts.
  - Otherwise, it may cause the failure of machine or electrical shock.
- Hold the plug by the head when taking it out.
  - It may cause electric shock and damage.
- Never touch the metal parts of the unit when removing the filter.
  - They are sharp and may cause injury.
- Do not step on the indoor/outdoor unit and do not put anything on it.
  - It may cause an injury through dropping of the unit or falling down.
- Do not place a heavy object on the power cord.
  - Otherwise, it may cause a fire or electrical shock.
- When the product is submerged into water, always contact the service center.
  - Otherwise, it may cause a fire or electrical shock.
- Take care so that children may not step on the outdoor unit.
  - Otherwise, children may be seriously injured due to falling down.
- The appliance shall be stored so as to prevent mechanical damage from occurring.
- This appliance is not intended for use by persons (including children) with reduced physical, sensory or mental capabilities or lack of experience and knowledge, unless they have been given supervision or instruction concerning use of the appliance by a person responsible for their safety. Children should be supervised to ensure that they do not play with the appliance.
- LEAK DETECTION SYSTEM installed. Unit must be powered except for service. This unit is equipped with a refrigerant leak detector for safety. To be effective, the unit must be electrically powered at all times after installation, other than when servicing.
- The appliance shall be installed in accordance with national wiring regulations.
- Means for disconnection must be incorporated in the fixed wiring in accordance with the wiring rules.
- If the supply cord is damaged, it must be replaced by the manufacturer, its service agent or similarly qualified persons in order to avoid a hazard.

## **Service & Installation**

### **Checks to the area**

Prior to beginning work on systems containing flammable refrigerants, safety checks are necessary to ensure that the risk of ignition is minimised. For repair to the refrigerating system, the following precautions shall be complied with prior to conducting work on the system.

### **Work procedure**

Work shall be undertaken under a controlled procedure so as to minimise the risk of a flammable gas or vapour being present while the work is being performed.

### **General work area**

All maintenance staff and others working in the local area shall be instructed on the nature of work being carried out. Work in confined spaces shall be avoided.

### **Checking for presence of refrigerant**

The area shall be checked with an appropriate refrigerant detector prior to and during work, to ensure the technician is aware of potentially flammable atmospheres. Ensure that the leak detection equipment being used is suitable for use with flammable refrigerants, i.e. non-sparking, adequately sealed or intrinsically safe.

### **Presence of fire extinguisher**

If any hot work is to be conducted on the refrigerating equipment or any associated parts, appropriate fire extinguishing equipment shall be available to hand. Have a dry powder or CO2 fire extinguisher adjacent to the charging area.

### **No ignition sources**

No person carrying out work in relation to a refrigerating system which involves exposing any pipe work shall use any sources of ignition in such a manner that it may lead to the risk of fire or explosion.

All possible ignition sources, including cigarette smoking, should be kept sufficiently far away from the site of installation, repairing, removing and disposal, during which refrigerant can possibly be released to the surrounding space. Prior to work taking place, the area around the equipment is to be surveyed to make sure that there are no flammable hazards or ignition risks. "No Smoking" signs shall be displayed.

### **Ventilated area**

Ensure that the area is in the open or that it is adequately ventilated before breaking into the system or conducting any hot work. A degree of ventilation shall continue during the period that the work is carried out.

The ventilation should safely disperse any released refrigerant and preferably expel it externally into the atmosphere.

### **Checks to the refrigerating equipment**

Where electrical components are being changed, they shall be fit for the purpose and to the correct specification.

At all times the manufacturer's maintenance and service guidelines shall be followed. If in doubt consult the manufacturer's technical department for assistance.

The following checks shall be applied to installations using flammable refrigerants:

- The actual refrigerant charge is in accordance with the room size within which the refrigerant containing parts are installed
- The ventilation machinery and outlets are operating adequately and are not obstructed

- If an indirect refrigerating circuit is being used, the secondary circuit shall be checked for the presence of refrigerant
- Marking to the equipment continues to be visible and legible. Markings and signs that are illegible shall be corrected
- Refrigerating pipe or components are installed in a position where they are unlikely to be exposed to any substance which may corrode refrigerant containing components, unless the components are constructed of materials which are inherently resistant to being corroded or are suitably protected against being so corroded.

### Checks to electrical devices

Repair and maintenance to electrical components shall include initial safety checks and component inspection procedures. If a fault exists that could compromise safety, then no electrical supply shall be connected to the circuit until it is satisfactorily dealt with. If the fault cannot be corrected immediately but it is necessary to continue operation, an adequate temporary solution shall be used. This shall be reported to the owner of the equipment so all parties are advised.

Initial safety checks shall include:

- Capacitors are discharged: this shall be done in a safe manner to avoid possibility of sparking.
- No live electrical components and wiring are exposed while charging, recovering or purging the system.
- Continuity of earth bonding

### Repairs to sealed components

Sealed electrical components shall be replaced.

### Repair to intrinsically safe components

Intrinsically safe components must be replaced.

### Cabling

Check that cabling will not be subject to wear, corrosion, excessive pressure, vibration, sharp edges or any other adverse environmental effects. The check shall also take into account the effects of aging or continual vibration from sources such as compressors or fans.

### Detection of flammable refrigerants

Under no circumstances shall potential sources of ignition be used in the searching for or detection of refrigerant leaks. A halide torch (or any other detector using a naked flame) shall not be used.

### Leak detection methods

The following leak detection methods are deemed acceptable for all refrigerant systems.

Electronic leak detectors may be used to detect refrigerant leaks but, in the case of FLAMMABLE REFRIGERANTS, the sensitivity may not be adequate, or may need re-calibration. (Detection equipment shall be calibrated in a refrigerant-free area.) Ensure that the detector is not a potential source of ignition and is suitable for the refrigerant used. Leak detection equipment shall be set at a percentage of the LFL of the refrigerant and shall be calibrated to the refrigerant employed, and the appropriate percentage of gas (25 % maximum) is confirmed.

Leak detection fluids are also suitable for use with most refrigerants but the use of detergents containing chlorine shall be avoided as the chlorine may react with the refrigerant and corrode the copper pipe-work.

If a leak is suspected, all naked flames shall be removed / extinguished.

If a leakage of refrigerant is found which requires brazing, all of the refrigerant shall be recovered from the system, or isolated (by means of shut off valves) in a part of the system remote from the leak. Removal of refrigerant shall be according to removal and evacuation procedure.

## Removal and evacuation

When breaking into the refrigerant circuit to make repairs – or for any other purpose – conventional procedures shall be used. However, for flammable refrigerants it is important that best practice be followed, since flammability is a consideration.

The following procedure shall be adhered to:

- Safely remove refrigerant following local and national regulations;
- Evacuate;
- Purge the circuit with inert gas (optional for A2L);
- Evacuate (optional for A2L);
- Continuously flush or purge with inert gas when using flame to open circuit; and
- Open the circuit.

The refrigerant charge shall be recovered into the correct recovery cylinders if venting is not allowed by local and national codes. For appliances containing flammable refrigerants, the system shall be purged with oxygen-free nitrogen to render the appliance safe for flammable refrigerants. This process might need to be repeated several times.

Compressed air or oxygen shall not be used for purging refrigerant systems.

For appliances containing flammable refrigerants, refrigerants purging shall be achieved by breaking the vacuum in the system with oxygen-free nitrogen and continuing to fill until the working pressure is achieved, then venting to atmosphere, and finally pulling down to a vacuum (optional for A2L). This process shall be repeated until no refrigerant is within the system (optional for A2L). When the final oxygen-free nitrogen charge is used, the system shall be vented down to atmospheric pressure to enable work to take place. The outlet for the vacuum pump shall not be close to any potential ignition sources, and ventilation shall be available.

## Charging procedures

In addition to conventional charging procedures, the following requirements shall be followed.

- Ensure that contamination of different refrigerants does not occur when using charging equipment. Hoses or lines shall be as short as possible to minimise the amount of refrigerant contained in them.
- Cylinders shall be kept in an appropriate position according to the instruction.
- Ensure that the refrigerating system is earthed prior to charging the system with refrigerant.
- Label the system when charging is complete (if not already).
- Extreme care shall be taken not to overfill the refrigerating system.

Prior to recharging the system, it shall be pressure tested with the appropriate purging gas.

The system shall be leak-tested on completion of charging but prior to commissioning. A follow up leak test shall be carried out prior to leaving the site.

## Decommissioning

Before carrying out this procedure, it is essential that the technician is completely familiar with the equipment and all its detail.

It is recommended good practice that all refrigerants are recovered safely.

Prior to the task being carried out, an oil and refrigerant sample shall be taken in case analysis is required prior to re-use of recovered refrigerant.

It is essential that electrical power is available before the task is commenced.

- a) Become familiar with the equipment and its operation.
- b) Isolate system electrically.
- c) Before attempting the procedure ensure that:
  - Mechanical handling equipment is available, if required, for handling refrigerant cylinders
  - All personal protective equipment is available and being used correctly
  - The recovery process is supervised at all times by a competent person
  - Recovery equipment and cylinders conform to the appropriate standards.

- d) Pump down refrigerant system, if possible.
- e) If a vacuum is not possible, make a manifold so that refrigerant can be removed from various parts of the system.
- f) Make sure that cylinder is situated on the scales before recovery takes place.
- g) Start the recovery machine and operate in accordance with instructions.
- h) Do not overfill cylinders. (No more than 80 % volume liquid charge).
- i) Do not exceed the maximum working pressure of the cylinder, even temporarily.
- j) When the cylinders have been filled correctly and the process completed, make sure that the cylinders and the equipment are removed from site promptly and all isolation valves on the equipment are closed off.
- k) Recovered refrigerant shall not be charged into another refrigerating system unless it has been cleaned and checked.

#### NOTE

**Examples of leak detection fluids are**

- Bubble method
- Fluorescent method agents

#### Labelling

Equipment shall be labelled stating that it has been de-commissioned and emptied of refrigerant. The label shall be dated and signed.

Ensure that there are labels on the equipment stating the equipment contains flammable refrigerant.

#### Recovery

When removing refrigerant from a system, either for servicing or decommissioning, it is recommended good practice that all refrigerants are removed safely.

When transferring refrigerant into cylinders, ensure that only appropriate refrigerant recovery cylinders are employed.

Ensure that the correct number of cylinders for holding the total system charge is available.

All cylinders to be used are designated for the recovered refrigerant and labelled for that refrigerant (i.e. special cylinders for the recovery of refrigerant).

Cylinders shall be complete with pressure-relief valve and associated shut-off valves in good working order.

Empty recovery cylinders are evacuated and, if possible, cooled before recovery occurs.

The recovery equipment shall be in good working order with a set of instructions concerning the equipment that is at hand and shall be suitable for the recovery of the flammable refrigerant.

If in doubt, the manufacturer should be consulted. In addition, a set of calibrated weighing scales shall be available and in good working order.

Hoses shall be complete with leak-free disconnect couplings and in good condition.

The recovered refrigerant shall be processed according to local legislation in the correct recovery cylinder, and the relevant waste transfer note arranged.

Do not mix refrigerants in recovery units and especially not in cylinders .

If compressor or compressor oils are to be removed, ensure that they have been evacuated to an acceptable level to make certain that flammable refrigerant does not remain within the lubricant.

The compressor body shall not be heated by an open flame or other ignition sources to accelerate this process.

When oil is drained from a system, it shall be carried out safely.

## CAUTION

### **Installation**

- Install the drain hose to ensure that drain can be securely done.
  - Otherwise, it may cause water leakage.
- Install the product so that the noise or hot wind from the outdoor unit may not cause any damage to the neighbors.
  - Otherwise, it may cause dispute with the neighbors.
- Always inspect gas leakage after the installation and repair of product.
  - Otherwise, it may cause the failure of product.
- Keep level parallel in installing the product.
  - Otherwise, it may cause vibration or water leakage.
- Do not install the unit in potentially explosive atmospheres.
- The installation of pipe-work shall be kept to a minimum
- Any person who is involved with working on or breaking into a refrigerant circuit should hold a current valid certificate from an industry-accredited assessment authority, which authorises their competence to handle refrigerants safely in accordance with an industry recognised assessment specification.
- When mechanical connectors are reused indoors, sealing parts shall be renewed.
- When flared joints are reused indoors, the flare part shall be re- fabricated.

### **Operation**

- Avoid excessive cooling and perform ventilation sometimes.
  - Otherwise, it may do harm to your health.
- Use a soft cloth to clean. Do not use wax, thinner, or a strong detergent.
  - The appearance of the air conditioner may deteriorate, change color, or develop surface flaws.
- Do not use an appliance for special purposes such as preserving animals vegetables, precision machine, or art articles.
  - Otherwise, it may damage your properties.
- Do not place obstacles around the flow inlet or outlet.
  - Otherwise, it may cause the failure of appliance or an accident.
- This appliance is not intended for the purposes of cooling INFORMATION TECHNOLOGY EQUIPMENT
- Servicing shall only be performed as recommended by the equipment manufacturer. Maintenance and repair requiring the assistance of other skilled personnel shall be carried out under the supervision of the person competent in the use of flammable refrigerants.

### **Service & Installation**

- Servicing shall be performed only as recommended by the manufacturer.

# TABLE OF CONTENTS

## 2 TIPS FOR SAVING ENERGY

---

## 3 SAFETY INSTRUCTIONS

---

## 13 INSTALLATION OF OUTDOOR UNIT

---

13 Installation Places

13 Piping length and the elevation

## 14 WIRING CONNECTION

---

14 Electrical Wiring

14 Connecting Cables between Indoor Unit and Outdoor Unit

17 Connecting the cable to Outdoor Unit

## 19 CONNECTING COPPER PIPES

---

19 Preparation of Piping

20 Plumbing materials and storage methods

21 Connecting the pipes to the Outdoor unit

## 22 CHARGING

---

23 Forming the piping

## 24 LEAKAGE TEST AND EVACUATION

---

24 Preparation

24 Leakage test

25 Evacuation

## 26 TEST RUNNING

---

## 27 SELF-DIAGNOSIS FUNCTION

---

29 DIP S/W Setting

## 31 INSTALLATION GUIDE AT THE SEASIDE

---

## 32 SEASONAL WIND AND CAUTIONS IN WINTER

---

# INSTALLATION OF OUTDOOR UNIT

## Installation Places

- If an awning is built over the unit to prevent direct sunlight or rain exposure, make sure that heat radiation from the condenser is not restricted.
- Ensure that the spaces indicated by arrows around front, back and side of the unit.
- Do not place animals and plants in the path of the warm air.
- Take the air conditioner weight into account and select a place where noise and vibration are minimum.
- Select a place so that the warm air and noise from the air conditioner do not disturb neighbors.

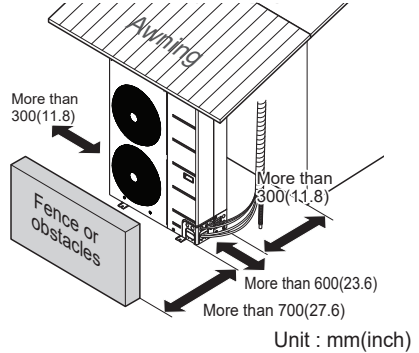

## Piping length and the elevation

### ■ MAHU Combination (Model Name : KNSLA\*\*1A, KNSLB\*\*1A)

Unit : mm(inch)

Model	Pipe Size mm(inch)				Length A Unit : m(ft)		Elevation B Unit : m(ft)		Additional refrigerant Unit : g(m/oz)ft)	
	Rated Pipe Size		Alternate Pipe Size		Standard	Max.	Standard	Max.	Rated Pipe Size	Alternate Pipe Size
	Gas	Liquid	Gas	Liquid						
KUSXB091A KUSXB121A	Ø 9.52 (3/8)	Ø 6.35 (1/4)	-	-	7.5 (24.6)	20 (66)	5 (16)	15 (49)	20 (0.22)	-
KUSXA121A	Ø 9.52 (3/8)	Ø 6.35 (1/4)	-	-	7.5 (24.6)	50 (164)	5 (16)	30 (98)	35 (0.38)	-
KUSXB181A KUSXB241A KUSXB301A KUSXA181A KUSXA241A	Ø15.88 (5/8)	Ø 9.52 (3/8)	Ø19.05 (3/4)	Ø9.52 (3/8)	7.5 (24.6)	50 (164)	5 (16)	30 (98)	35 (0.38)	37 (0.40)
KUSXB361A KUSXB421A KUSXB481A KUSXA301A KUSXA361A	Ø15.88 (5/8)	Ø 9.52 (3/8)	Ø19.05 (3/4)	Ø9.52 (3/8)	7.5 (24.6)	75 (246)	5 (16)	30 (98)	40 (0.43)	42 (0.45)
KUSXA421A KUSXA422A KUSXA481A KUSXA482A	Ø15.88 (5/8)	Ø 9.52 (3/8)	Ø19.05 (3/4)	Ø9.52 (3/8)	7.5 (24.6)	75 (246)	5 (16)	30 (98)	40 (0.43)	42 (0.45)
KUSXB601A	Ø19.05 (3/4)	Ø 9.52 (3/8)	Ø22.22 (7/8)	Ø9.52 (3/8)	7.5 (24.6)	75 (246)	5 (16)	30 (98)	40 (0.43)	43 (0.46)

### ■ A-Coil Combination (Model Name : LKMMMA\*\*\*\*)

Model	Pipe Size mm(inch)				Length A Unit : m(ft)		Elevation B Unit : m(ft)		Additional refrigerant Unit : g(m/oz)ft)	
	Rated Pipe Size		Alternate Pipe Size		Standard	Max.	Standard	Max.	Rated Pipe Size	Alternate Pipe Size
	Gas	Liquid	Gas	Liquid						
KUSXB181A KUSXB241A KUSXB301A KUSXA181A KUSXA241A	Ø19.05 (3/4)	Ø9.52 (3/8)	Ø22.22 (7/8)	Ø9.52 (3/8)	7.5 (24.6)	50 (164)	5 (16)	30 (98)	35 (0.38)	38 (0.41)
KUSXB361A KUSXB421A KUSXB481A KUSXA301A KUSXA361A	Ø19.05 (3/4)	Ø9.52 (3/8)	Ø22.22 (7/8)	Ø9.52 (3/8)	7.5 (24.6)	75 (246)	5 (16)	30 (98)	40 (0.43)	43 (0.48)
KUSXA421A KUSXA422A KUSXA481A KUSXA482A	Ø19.05 (3/4)	Ø9.52 (3/8)	Ø22.22 (7/8)	Ø9.52 (3/8)	7.5 (24.6)	75 (246)	5 (16)	30 (98)	40 (0.43)	43 (0.48)
KUSXB601A	Ø19.05 (3/4)	Ø9.52 (3/8)	Ø22.22 (7/8)	Ø9.52 (3/8)	7.5 (24.6)	75 (246)	5 (16)	30 (98)	40 (0.43)	43 (0.48)

- The table provides the rated and alternate pipe size for R32 model.
  - When using an installation pipe of an alternative pipe size, additional refrigerant charge adjustment is required.
  - If installed tube is shorter than 7.5 m(24.6 ft), additional refrigerant charging is not necessary.
- Additional Refrigerant = [A - 7.5 m(24.6 ft)] x Additional refrigerant [g(oz)].

- In case of A-Coil combination (30~60kBTu/h, Exception KUSXB301A), charge additional refrigerant.

Additional refrigerant = 400g (14.1oz)

Ex) If installed tube is shorter than 7.5 m(24.6 ft), Charge additional refrigerant for A-Coil Combination [g(oz)]

Ex) If installed tube is more than 7.5 m(24.6 ft),

Total Additional Refrigerant

= { [A - 7.5 m(24.6 ft)] x Additional refrigerant [g(oz)] } + additional refrigerant for A-Coil Combination [g(oz)]

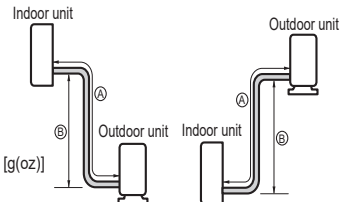

# WIRING CONNECTION

## Electrical Wiring

- All wiring must comply with local requirements.
- Select a power source that is capable of supplying the current required by the air conditioner.
- Use a recognized ELCB(Electric Leakage Circuit Breaker) between the power source and the unit. A disconnection device to adequately disconnect all supply lines must be fitted.
- Model of circuit breaker recommended by authorized personnel only.

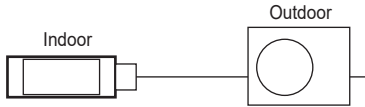
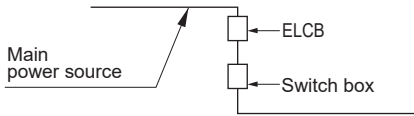

Model	Power Source	ELCB (A)
KUSXB091A KUSXB121A	1Ø, 208/230 V	15
KUSXB181A KUSXB241A	1Ø, 208/230 V	25
KUSXA121A KUSXA181A KUSXA241A KUSXB301A	1Ø, 208/230 V	30
KUSXA301A KUSXB361A KUSXA361A	1Ø, 208/230 V	35
KUSXB421A KUSXA421A KUSXA422A KUSXB481A KUSXA481A KUSXA482A KUSXB601A	1Ø, 208/230 V	40

## Connecting Cables between Indoor Unit and Outdoor Unit

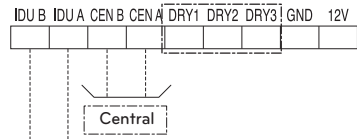
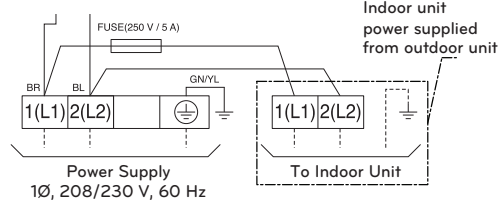

Indoor Unit Communication

: The feature may be changed according to the type of model.

### < installing Coil & Furnace (Thermostat)>

#### - 1 Stage

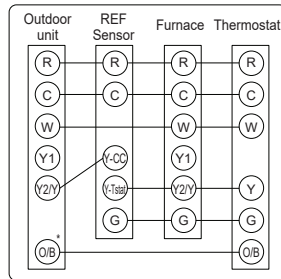

#### - 2 Stage

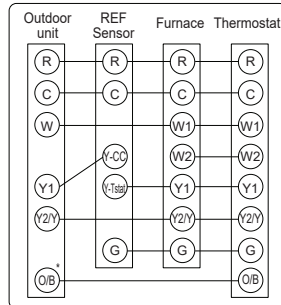

\* Outdoor unit default "O" type. (Heat Pump setting)

- It can change to "B" type by setting up the DIP switch.

## RECOMMENDATION

**The power cord connected to the outdoor unit should comply with the following specifications:** NRTL Recognized (for example, UL or ETL recognized and CSA certified).

As always, final wire selection is governed by local codes and should be installed by a licensed professional contractor.

[Power supply cable]

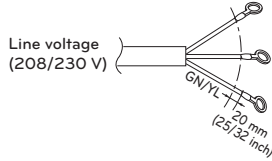

Outdoor Unit Capacity (kBtu/h class)	The minimum recommended wire size
9, 12(KUSXB121A)	AWG 14-3
12(KUSXA121A), 18, 24, 30(KUSXB301A)	AWG 12-3
30(KUSXA301A), 36, 42, 48, 60	AWG 10-3

Please refer to the instructions below for proper installation.

- Power wiring/power wiring gauge to the outdoor unit(s) must be solid or stranded and must comply with all National Electrical Code (NEC), UL, and local electrical codes.
- Power wiring cable from the outdoor unit to the indoor unit must be a minimum of 14 AWG, 3-conductor, solid core or stranded, rated for 600 V.
- Communication wiring cable from the outdoor unit to the indoor unit must be minimum 18 AWG, 2-conductor, twisted, stranded, and shielded (shield must be grounded to the outdoor unit chassis only).

[Connecting cable]

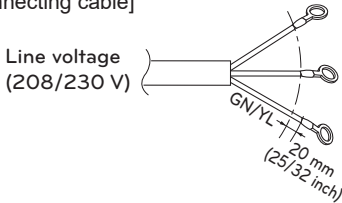

Power supply cable

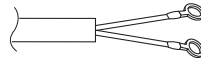

Communication cable

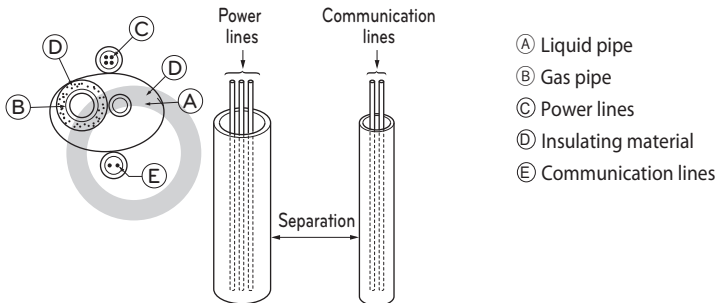

- A Liquid pipe
- B Gas pipe
- C Power lines
- D Insulating material
- E Communication lines

## Precautions when laying power and ground wiring

Use round pressure terminals for connections to the power terminal block. When laying ground wiring, you must use round pressure terminals.

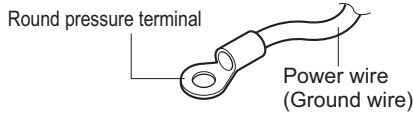

When none are available, follow the instructions below.

- Do not connect wiring of different thicknesses to the power terminal block. (Slack in the power wiring may cause abnormal heat.)
- When connecting wiring which is the same thickness, do as shown in the figure below.

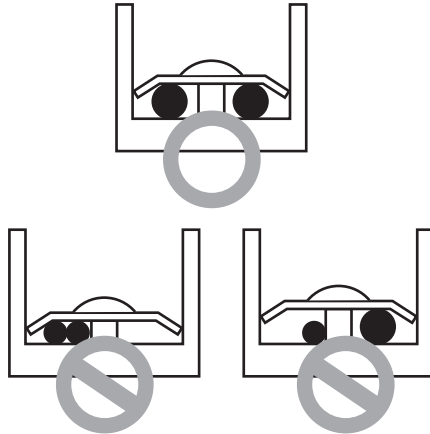

- For wiring, use the designated power wire and connect firmly, then secure to prevent outside pressure being exerted on the terminal block.
- Use an appropriate screwdriver for tightening the terminal screws. A screwdriver with a small head will strip the head and make proper tightening impossible.
- Over-tightening the terminal screws may break them.

## Connecting the cable to Outdoor Unit

- Remove the side panel for wiring connection.
- Use the cord clamp to fix the cord.
- Earthing work  
Connect the cable of diameter more to the earthing terminal provided in the control box and do earthing.

### 9, 12 (KUSXB121A) kBtu/h

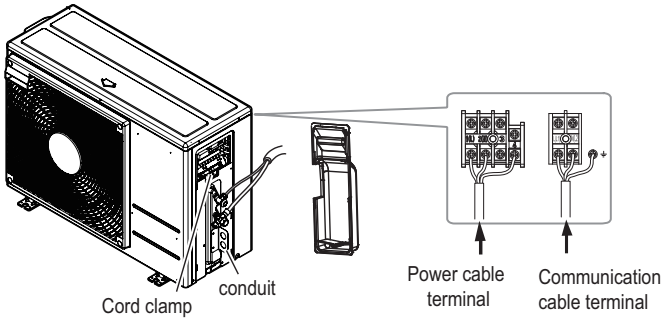

### 12 (KUSXA121A), 18, 24, 30 (KUSXB301A) kBtu/h

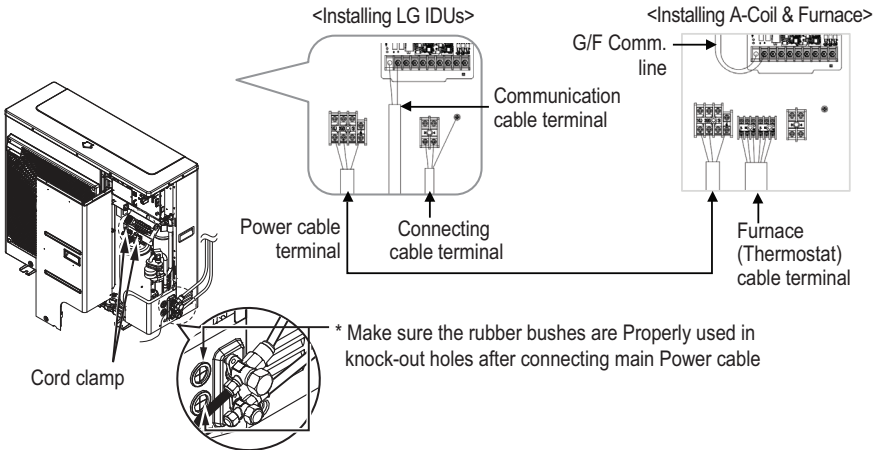

30(KUSXA301A), 36, 42, 48, 60 kBtu/h

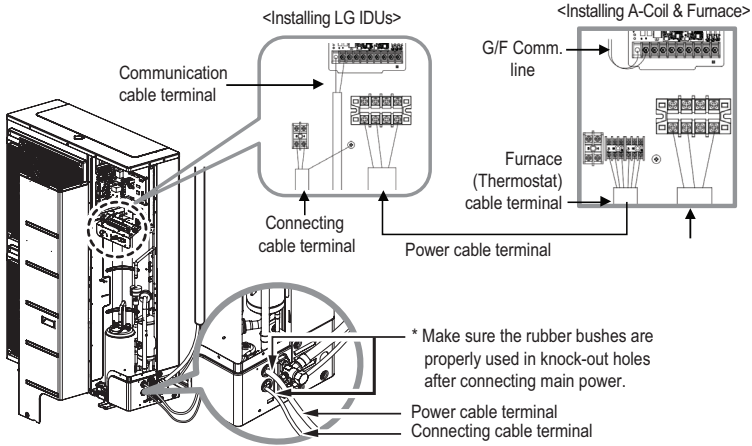

**CAUTION**

- The circuit diagram is not subject to change without notice.
- Be sure to connect wires according to the wiring diagram.
- Connect the wires firmly, so that not to be pulled out easily.
- Connect the wires according to color codes by referring the wiring diagram.

**CAUTION**

- The Power cord connected to the unit should be selected according to the following specifications.

# CONNECTING COPPER PIPES

## Preparation of Piping

Main cause of gas leakage is defect in flaring work. Carry out correct flaring work in the following procedure.

### Cut the pipes and the cable.

- Use the accessory piping kit or the pipes purchased locally.
- Measure the distance between the indoor and the outdoor unit.
- Cut the pipes a little longer than measured distance.
- Cut the cable 1.5 m(4.9 ft) longer than the pipe length.

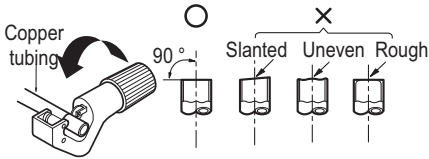

### Burrs removal

- Completely remove all burrs from the cut cross section of pipe.
- Put the end of the copper tubing to downward direction as you remove chips in order to avoid to let chips drop in the pipe.

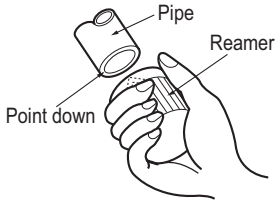

### Putting nut on

- Remove flare nuts attached to indoor and outdoor units, than put them on pipe/tube having completed burr removal. (Not possible to put them on after flaring work)

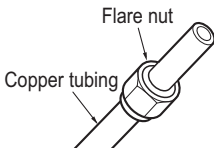

## Flaring work

- Firmly hold copper tube in a bar(or die) as indicated dimension in the table above.
- Carry out flaring work using dedicated flaring tool for R-410A as shown below.

Pipe diameter Inch (mm)	A inch (mm)	
	Wing nut type	Clutch type
Ø 1/4 (Ø 6.35)	0.04~0.05 (1.1~1.3)	0~0.02 (0~0.5)
Ø 3/8 (Ø 9.52)	0.06~0.07 (1.5~1.7)	
Ø 1/2 (Ø 12.7)	0.06~0.07 (1.6~1.8)	
Ø 5/8 (Ø 15.88)	0.06~0.07 (1.6~1.8)	
Ø 3/4 (Ø 19.05)	0.07~0.08 (1.9~2.1)	

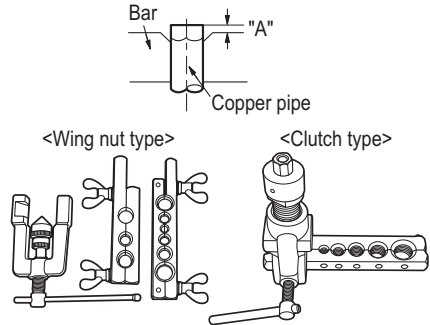

## Check

- Compare the flared work with figure below.
- If flare is noted to be defective, cut off the flared section and do flaring work again.

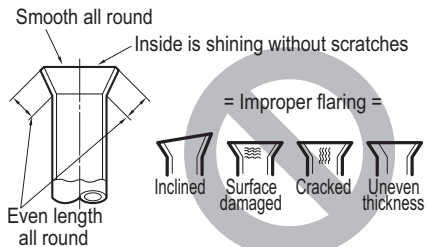

**NOTE**

Always blow nitrogen into pipe which is brazed. Always use a non-oxidizing brazing material for brazing the parts and do not use flux. If not, oxidized film can cause clogging or damage to the compressor unit and flux can harm the copper piping or refrigerant oil.

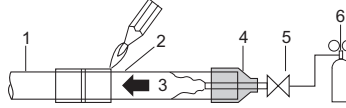

1	Refrigerant piping	4	Taping
2	Pipe to be brazed	5	Valve
3	Nitrogen	6	Pressure-reducing valve

- The torch tip should be positioned at the opposite angle to show the correct way to apply heat on the pipe coupling.

**Plumbing materials and storage methods**

Pipe must be able to obtain the specified thickness and should be used with low impurities. Also when handling storage, pipe must be careful to prevent a fracture, deformity and wound.

Should not be mixed with contaminations such as dust, moisture.

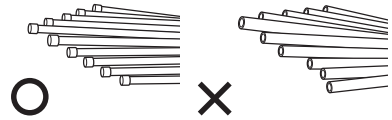

**Refrigerant piping on three principles**

	<b>Drying</b>	<b>Cleanliness</b>	<b>Airtight</b>
	Should be no moisture inside	No dust inside.	There is no refrigerant leakage
<b>Items</b>			
<b>Cause failure</b>	<ul style="list-style-type: none"> <li>- Significant hydrolysis of refrigerant oil</li> <li>- Degradation of refrigerant oil</li> <li>- Poor insulation of the compressor</li> <li>- Do not cold and warm</li> <li>- Clogging of EEV, Capillary</li> </ul>	<ul style="list-style-type: none"> <li>- Degradation of refrigerant oil</li> <li>- Poor insulation of the compressor</li> <li>- Do not cold and warm</li> <li>- Clogging of EEV, Capillary</li> </ul>	<ul style="list-style-type: none"> <li>- Gas shortages</li> <li>- Degradation of refrigerant oil</li> <li>- Poor insulation of the compressor</li> <li>- Do not cold and warm</li> </ul>
<b>Countermeasure</b>	<ul style="list-style-type: none"> <li>- No moisture in the pipe</li> <li>- Until the connection is completed, the plumbing pipe entrance should be strictly controlled.</li> <li>- Stop plumbing at rainy day.</li> <li>- Pipe entrance should be taken side or bottom.</li> <li>- When removal burr after cutting pipe, pipe entrance should be taken down.</li> <li>- Pipe entrance should be fitted cap when pass through the walls.</li> </ul>	<ul style="list-style-type: none"> <li>- No dust in the pipe.</li> <li>- Until the connection is completed, the plumbing pipe entrance should be strictly controlled.</li> <li>- Pipe entrance should be taken side or bottom.</li> <li>- When removal burr after cutting pipe, pipe entrance should be taken down.</li> <li>- Pipe entrance should be fitted cap when pass through the walls.</li> </ul>	<ul style="list-style-type: none"> <li>- Airtightness test should be.</li> <li>- Brazing operations to comply with standards.</li> <li>- Flare to comply with standards.</li> <li>- Flange connections to comply with standards.</li> </ul>

## Connecting the pipes to the Outdoor unit

- Align the center of the piping and sufficiently tighten the flare nut by hand.
- Finally, tighten the flare nut with torque wrench until the wrench clicks. When tightening the flare nut with torque wrench, ensure the direction for tightening follows the arrow on the wrench.

Piping Size		Torque		
mm	inch	kgf·cm	N·m	lbf·ft
Ø 6.35	Ø 1/4	180 ~ 250	17.6 ~ 24.5	13 ~ 18
Ø 9.52	Ø 3/8	340 ~ 420	33.3 ~ 41.2	25 ~ 30
Ø 15.88	Ø 5/8	630 ~ 820	61.7 ~ 80.4	45 ~ 59
Ø 12.7	Ø 1/2	550 ~ 660	53.9 ~ 64.7	40 ~ 48
Ø 19.05	Ø 3/4	990 ~ 1 210	97.0 ~ 118.7	71 ~ 87

\* When connecting the A-Coil to the Outdoor unit, connect the installed pipe by brazing.

IDU	Capacity (kBTu/h)	Installed pipe size (inch (mm))	
		Liquid	Gas
A-Coil	18	3/8 (Ø 9.52)	3/4 (Ø19.05)
	24		
	30		
	36		
	42		
	48		
	60	3/8 (Ø 9.52)	3/4 (Ø19.05) ~7/8 (Ø22.22)

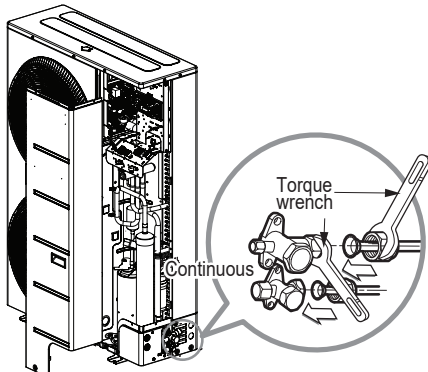

\* When tighten the pipe, hold the hexagonal body.

## Use the accessory Connector for Air Handler or A-Coil connection pipe

- When installing the Air Handler or A-Coil, use the connector provided as an accessory.
- Connect the nut of the connector to the outdoor unit, then braze the appropriate pipe diameter on the other side.

## Piping Insulation

- The gas pipe must always be insulated
- DO NOT allow the liquid pipe and gas pipe to come in direct (metal to metal) contact.

## NOTE

Insulate the liquid pipe if any of the following conditions apply:

- Cooling Mode: When the liquid line passes through an area where the temperature may reach 30°F (-1°C) or exceed the outdoor ambient temperature.
- Heating Mode: When the liquid line passes through an area where the indoor temperature may fall below the outdoor ambient temperature.
- When the outdoor unit is combined with CST, Duct, or Console indoor units.

## Preventing foreign objects from entering (Figure1)

- Plug the pipe through-holes with putty or insulation material (procured locally) to stop up all gaps, as shown in the figure 1.

<Figure 1>

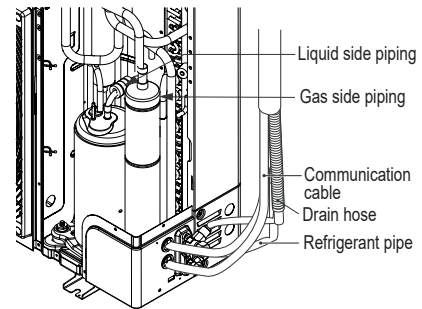

## CAUTION

- Insects or small animals entering the outdoor unit may cause a short circuit in the electrical box.

# CHARGING

## Checking the safe handling

Note down all of the following information on the label, especially the resulting total REFRIGERANT CHARGE for each REFRIGERATING SYSTEM

- ① Refrigerant charge of the precharged part of the appliance
- ② Refrigerant charge added during installation
- Total REFRIGERANT CHARGE
- Refrigerant type
- Date of first charge

① =  oz. /  kg

② =  oz. /  kg

①+② =  oz. /  kg

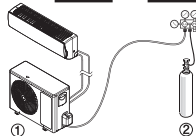

Refrigerant type  
Type de réfrigérant

Date of first charge  
Date de la première charge  
mm / dd / yyyy

 /  / 

Mark refrigerant pipes with red Pantone® Matching System (PMS) #185 or RAL 3020 after flare fittings or brazing. This marking must extend a minimum of 1 inch (25mm) in both directions and shall be replaced if removed.

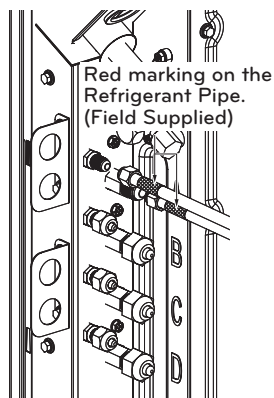

Return all labels, especially red marking, to their original condition to ensure the next consumer or servicer is aware of the presence of a flammable refrigerant.

Ensure that the red marking for flammable refrigerant identification in the process tube area is visible following servicing.

\* The feature may be changed according to the type of model.

## Forming the piping

Form the piping by wrapping the connecting portion of the indoor unit with insulation material and secure it with two kinds of vinyl tape.

- If you want to connect an additional drain hose, the end of the drain outlet should be routed above the ground. Secure the drain hose appropriately.

In cases where the outdoor unit is installed below the indoor unit perform the following.

- 1 Tape the piping, drain hose and connecting cable from down to up.
- 2 Secure the tapped piping along the exterior wall using saddle or equivalent.

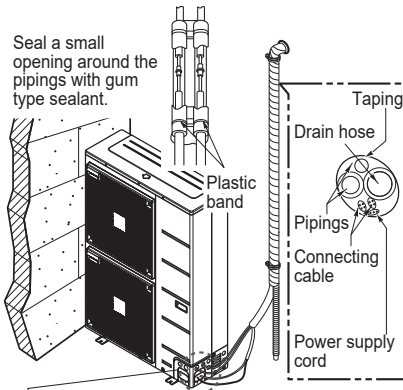

• Trap is required to prevent water from entering into electrical parts.

In cases where the outdoor unit is installed above the indoor unit perform the following.

- 1 Tape the piping and connecting cable from down to up.
- 2 Secure the taped piping along the exterior wall. Form a trap to prevent water entering the room.
- 3 Fix the piping onto the wall by saddle or equivalent.

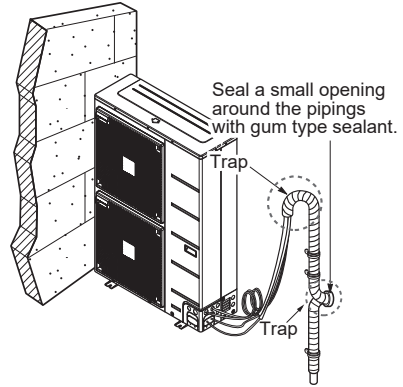

# LEAKAGE TEST AND EVACUATION

Air and moisture remaining in the refrigerant system have undesirable effects as indicated below.

- 1 Pressure in the system rises.
- 2 Operating current rises.
- 3 Cooling(or heating) efficiency drops.
- 4 Moisture in the refrigerant circuit may freeze and block capillary tubing.
- 5 Water may lead to corrosion of parts in the refrigeration system.

Therefore, the indoor/outdoor unit and connecting tube must be checked for leak tight, and vacuumed to remove incondensable gas and moisture in the system.

## Preparation

Check that each tube(both liquid and gas side tubes) between the indoor and outdoor units have been properly connected and all wiring for the test run has been completed. Remove the service valve caps from both the gas and the liquid side on the outdoor unit. Check that both the liquid and the gas side service valves on the outdoor unit are kept closed at this stage.

## Leakage test

Connect the manifold valve(with pressure gauges) and dry nitrogen gas cylinder to this service port with charge hoses.

### ! CAUTION

- Be sure to use a manifold valve for leakage test.  
If it is not available, use a stop valve for this purpose. The "Hi" knob of the manifold valve must always be kept close.

Pressurize the system to no more than 3.0 MPa (427 P.S.I.G) with dry nitrogen gas and close the cylinder valve when the gauge reading reached 3.0 MPa (427 P.S.I.G) Next, test for leaks with liquid soap.

### ! CAUTION

- To avoid nitrogen entering the refrigerant system in a liquid state, the top of the cylinder must be higher than its bottom when you pressurize the system. Usually, the cylinder is used in a vertical standing position.
- 1 Do a leakage test of all joints of the tubing(both Indoor unit and outdoor unit) and both gas and liquid side service valves.  
Bubbles indicate a leak. Be sure to wipe off the soap with a clean cloth.
  - 2 After the system is found to be free of leaks, relieve the nitrogen pressure by loosening the charge hose connector at the nitrogen cylinder. When the system pressure is reduced to normal, disconnect the hose from the cylinder.

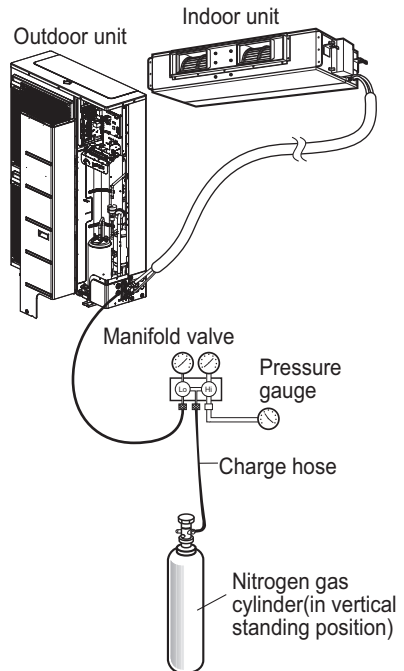

## Evacuation

- 1 Connect the charge hose end described in the preceding steps to the vacuum pump to evacuate the tubing and indoor unit. Confirm the "Lo and Hi" knob of the manifold valve is open. Then, run the vacuum pump. The operation time for evacuation varies with tubing length and capacity of the pump. The following table shows the time required for evacuation.

Required time for evacuation when 30 gal/h(114 l/h) vacuum pump is used	
If tubing length is less than 10 m(33 ft)	If tubing length is longer than 10 m(33 ft)
30 minutes or more	60 minutes or more
0.07 kPa (0.01 psi)(0.53 torr) or less	

- 2 When the desired vacuum is reached, close the "Lo and Hi" knob of the manifold valve and stop the vacuum pump.

## Finishing the job

- 1 With a service valve wrench, turn the valve stem of liquid side valve counter-clockwise to fully open the valve.
- 2 Turn the valve stem of gas side valve counter-clockwise to fully open the valve.
- 3 Loosen the charge hose connected to the gas side service port slightly to release the pressure, then remove the hose.
- 4 Replace the flare nut and its bonnet on the gas side service port and fasten the flare nut securely with an adjustable wrench. This process is very important to prevent leakage from the system.
- 5 Replace the valve caps at both gas and liquid side service valves and fasten them tight.

This completes air purging with a vacuum pump.

The air conditioner is now ready to test run.

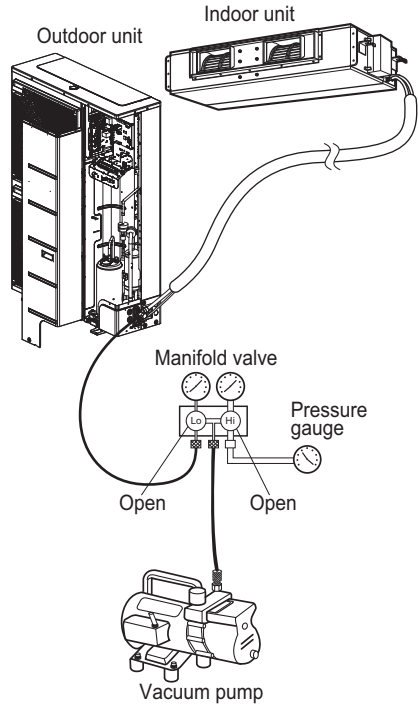

# TEST RUNNING

## Precautions in test running

- The initial power supply must provide at least 90 % of the rated voltage.  
Otherwise, the air conditioner should not be operated.

### NOTE

- For test run, carry out the cooling operation firstly even during heating season. If heating operation is carried out firstly, it leads to the trouble of compressor. Then attention must be paid.
- Carry out the test run more than 5 minutes without fail.  
(Test run will be cancelled 18 minutes later automatically)
  - The test run is started by pressing the room temperature checking button and down timer button for 3 seconds at the same time.
  - To cancel the test run, press any button.

## Check the following items when installation is complete

- After completing work, be sure to measure and record trial run properties, and store measured data, etc.
- Measuring items are room temperature, outside temperature, suction temperature, blow out temperature, wind velocity, wind volume, voltage, current, presence of abnormal vibration and noise, operating pressure, piping temperature, compressive pressure.
- As to the structure and appearance, check following items.
  - \* Is the circulation of air adequate?
  - \* Is the draining smooth?
  - \* Is the heat insulation complete (refrigerant and drain piping)?
  - \* Is there any leakage of refrigerant?
  - \* Is the remote controller switch operated?
  - \* Is there any faulty wiring?
  - \* Are not terminal screws loosened?

- M4.....118 N·cm (10.4 lbs·inch)
- M5.....196 N·cm (17.3 lbs·inch)
- M6.....245 N·cm (21.7 lbs·inch)
- M8.....588 N·cm (52 lbs·inch)

## Connection of power supply

- Connect the power supply cord to the independent power supply.  
Circuit breaker is required.
- Operate the unit for fifteen minutes or more.

## Evaluation of the performance

- Measure the temperature of the intake and discharge air.
- Ensure the difference between the intake temperature and the discharge one is more than 8 °C (Cooling) or reversely (Heating).

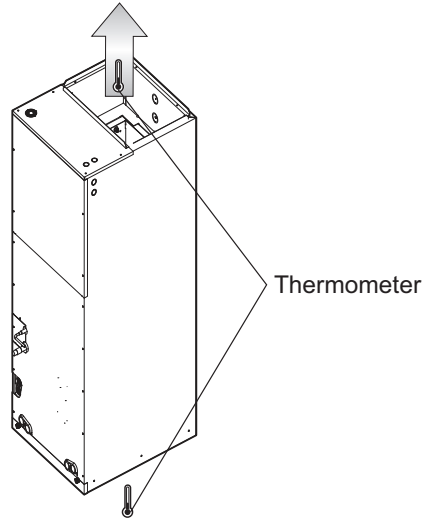

## HAND OVER

Teach the customer the operation and maintenance procedures, using the operation manual.  
(air filter cleaning, temperature control, etc.)

# SELF-DIAGNOSIS FUNCTION

## Error Indicator

- This function indicates types of failure in self-diagnosis and occurrence of failure for air condition.
- Error mark is displayed on display window of indoor units and wired remote controller, and 7-segment LED of outdoor unit control board as shown in the table.
- If more than two troubles occur simultaneously, lower number of error code is first displayed.
- After error occurrence, if error is released, error LED is also released simultaneously.

## Error Display

2nd, 3rd, 4th LED of 7-segment of main pcb indicates error number.

Ex) 

Main PCB

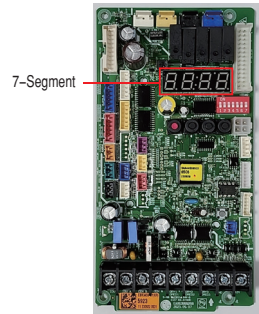







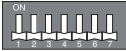

\* Indoor unit related errors are not displayed in the 7-segment of main PCB.

	Display			Title	Cause of Error
Indoor unit related error	0	1	-	Air temperature sensor of indoor unit	Air temperature sensor of indoor unit is open or short
	0	2	-	Inlet pipe temperature sensor of indoor unit	Inlet pipe temperature sensor of indoor unit is open or short
	0	3	-	Communication error : wired remote controller ↔ indoor unit	Failing to receive wired remote controller signal in indoor unit PCB
	0	4	-	Drain pump	Malfunction of drain pump
	0	5	-	Communication error : outdoor unit ↔ indoor unit	Failing to receive outdoor unit signal in indoor unit PCB
	0	6	-	Outlet pipe temperature sensor of indoor unit	Outlet pipe temperature sensor of indoor unit is open or short
	0	9	-	Indoor EEPROM Error	In case when the serial number marked on EEPROM of Indoor unit is 0 or FFFFFFFF
	1	0	-	Poor fan motor operation	Disconnecting the fan motor connector/Failure of indoor fan motor lock
Outdoor unit related error	2	1	1	Inv. PCB IPM Fault occur	Inv. PCB Drive IPM Fault
	2	2	1	AC Input Current Over Error	AC Input Current excess (RMS)
	2	3	1	Inverter Compressor DC link Low Voltage	DC charging is not performed at Outdoor Unit after starting relay turn on
	2	4	1	Excessive rise of discharge pressure in outdoor compressor	Compressor off due to the high pressure switch in outdoor unit
	2	5	1	Input Voltage High/ Low Voltage	Input voltage is over or less limited value
	2	6	1	Inverter Compressor Start Failure	Starting failure because of compressor abnormality
	2	7	1	PSC / PFC Fault Error	Over-current on AC ↔ DC converter circuit

Display			Title	Cause of Error	
Outdoor unit related error	2	9	1	Inverter Compressor Over Current	Inverter compressor input current is over limited value
	3	2	1	Over-increase discharge temp. of inverter compressor	Compressor is off because of over-increase discharge temp. of inverter compressor
	3	5	1	Excessive drop of discharge pressure of compressor	excessive drop of low pressure by the low pressure sensor
	4	0	1	Inverter Compressor CT Sensor Fault	Inverter Compressor CT Sensor open or short
	4	1	1	Discharge pipe temp. sensor error	Discharge pipe temp. sensor open or short
	4	3	1	Sensor error of high pressure	Pressure sensor open or short
	4	4	1	Air Temp. sensor error	Air Temp. sensor open or short
	4	5	1	Condenser mid-pipe Temp. sensor error	Condenser mid-pipe Temp. sensor open or short
	4	6	1	Suction pipe temp. sensor error	Suction pipe temp. sensor open or short
	4	8	1	Condenser out-pipe Temp. sensor error	Condenser out-pipe Temp. sensor open or short
	5	2	1	Communication error : inverter PCB ↔ Main PCB	Failing to receive inverter signal at main PCB of Outdoor Unit
	5	3	1	Communication error : indoor unit ↔ Main PCB of Outdoor Unit	Failing to receive indoor unit signal at main PCB of Outdoor Unit
	5	7	1	Communication error : Main PCB ↔ inverter PCB	Failing to receive signal main PCB at inverter PCB of Outdoor Unit
	6	1	1	Condenser overheating error	High temperature in outdoor condenser mid-pipe
	6	2	1	Inverter Heatsink High Temperature	Heatsink Temperature is over limited value
	6	7	1	Fan lock error	Outdoor Fan is not operation
7	3	1	AC input instant over current error (Matter of software)	Inverter PCB input power current is over limited value	
8	6	1	Main PCB EEPROM Error	Communication Fail Between Outdoor Unit Main MICOM and EEPROM or omitting EEPROM	
Refrigerant leakage sensor related error	2	2	8	Refrigerant leak detector malfunction error	Refrigerant leak detector has failed
	2	2	9	Refrigerant leak detector lifetime error	The lifetime of the refrigerant leak detector has reached the end
	2	3	0	Refrigerant leak detection error	Refrigerant leak detected by refrigerant leak detector
	2	3	6	Refrigerant leak detector lifetime pre-alarm	An error occurs once a month when the lifespan of the leak detector has elapsed 9 years and 6 months. An error occurs once a day when the lifespan of the leak detector has elapsed 9 years and 11 months.

## DIP S/W Setting

If you set the DIP Switch when power is on, the change in setting is not applicable. The changing setting is enabled only when Power is reset.

DIP Switch 1 2 3 4 5 6 7	Function
	Normal Operation (No Function)
	Pump Down
	Mode Lock (Cooling)
	Mode Lock (Heating)
	Night Quiet Mode (Step 1)
	Night Quiet Mode (Step 2)
	Mode Lock (Cooling) + Night Quiet Mode (Step 1)
	Mode Lock (Cooling) + Night Quiet Mode (Step 2)

### WARNING

- When you set the DIP switch, you should turn off the circuit breaker or shut the power source of the product down.

### NOTE

- Unless the applicable DIP switch is set properly, the product may not work.
- If you want to set a specific function, request that the installer sets the DIP switch appropriately during installation.

**Unitary Comm. Kit DIP S/W Setting**

If you set the DIP Switch when power is on, the change in setting is not applicable. The changing setting is enabled only when Power is reset.

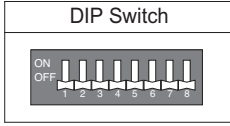

DIP Switch (SW01)	Function	ON	OFF
1	ODU Communication	X	O
2	Remote Controller	O	X
3	Thermostat H/P Setting	B Type	O Type
4	Stage Setting	1 Stage	2 Stage
5	Reserved	-	-
6	Reserved	-	-
7	Reserved	-	-
8	Reserved	-	-

**WARNING**

- When you set the DIP switch, you should turn off the circuit breaker or shut the power source of the product down.

**NOTE**

- Unless the applicable DIP switch is set properly, the product may not work.
- If you want to set a specific function, request that the installer sets the DIP switch appropriately during installation.

# INSTALLATION GUIDE AT THE SEASIDE

## NOTE

- Air conditioners should not be installed in areas where corrosive gases, such as acid or alkaline gas, are produced.
- Do not install the product where it could be exposed to sea wind (salty wind) directly. It can result corrosion on the product. Corrosion, particularly on the condenser and evaporator fins, could cause product malfunction or inefficient performance.
- If outdoor unit is installed close to the seaside, it should avoid direct exposure to the sea wind. Otherwise it needs additional anticorrosion treatment on the heat exchanger.

## Selecting the location(Outdoor unit)

If the outdoor unit is to be installed close to the seaside, direct exposure to the sea wind should be avoided. Install the outdoor unit on the opposite side of the sea wind direction.

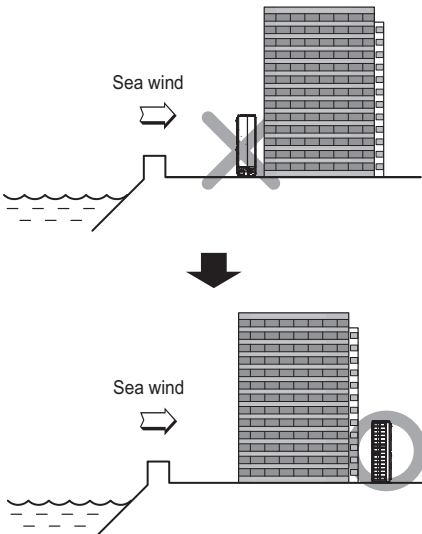

In case, to install the outdoor unit on the seaside, set up a windbreak not to be exposed to the sea wind.

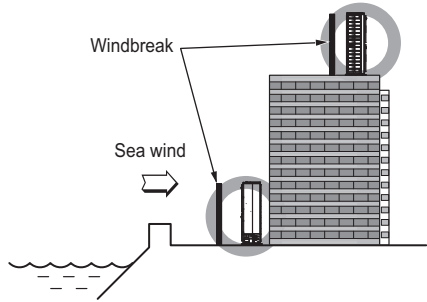

- It should be strong enough like concrete to prevent the sea wind from the sea.
- The height and width should be more than 150 % of the outdoor unit.
- It should be keep more than 70 cm of space between outdoor unit and the windbreak for easy air flow.

Select a well-drained place.

- Periodic ( more than once/year ) cleaning of the dust or salt particles stuck on the heat exchanger by using water

## SEASONAL WIND AND CAUTIONS IN WINTER

- Sufficient measures are required in a snow area or severe cold area in winter so that product can be operated well.
- Get ready for seasonal wind or snow in winter even in other areas.
- Install a suction and discharge duct not to let in snow or rain.
- Install the outdoor unit not to come in contact with snow directly. If snow piles up and freezes on the air suction hole, the system may malfunction. If it is installed at snowy area, attach the hood to the system.
- Install the outdoor unit at the higher installation console by 50 cm than the average snowfall (annual average snowfall) if it is installed at the area with much snowfall.
- Where snow accumulated on the upper part of the Outdoor Unit by more than 10 cm, always remove snow for operation.

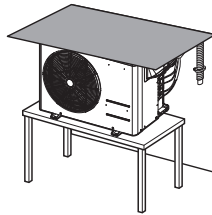

1. The height of H frame must be more than 2 times the snowfall and its width shall not exceed the width of the product. (If width of the frame is wider than that of the product, snow may accumulate)
2. Don't install the suction hole and discharge hole of the Outdoor Unit facing the seasonal wind.



US	Please call the installing contractor of your product, as warranty service will be provided by them.
CANADA	Service call Number # : (888) LG Canada, (888) 542-2623 Numéro pour les appels de service : LG Canada, 1-888-542-2623