



ENGLISH

FRANÇAIS

ESPAÑOL

INSTALLATION MANUAL

# AIR CONDITIONER

Please read this installation manual completely before installing the product. Installation work must be performed in accordance with the national wiring standards by authorized personnel only. Please retain this installation manual for future reference after reading it thoroughly.

MULTI  
Original instruction







MFL68883826  
Rev.02\_110525

[www.lghvac.com](http://www.lghvac.com)  
[www.lg.com](http://www.lg.com)

Copyright © 2024 - 2025 LG Electronics Inc. All Rights Reserved.

## SAFETY INSTRUCTIONS

	<p>Read the precautions in this manual carefully before operating the unit.</p>
	<p>This symbol indicates that the Operation Manual should be read carefully.</p>
	<p>This appliance is filled with flammable refrigerant.</p>
	<p>This symbol indicates that a service personnel should be handling this equipment with reference to the Installation Manual.</p>

The following safety guidelines are intended to prevent unforeseen risks or damage from unsafe or incorrect operation of the appliance. The guidelines are separated into 'WARNING' and 'CAUTION' as described below.

 This symbol is displayed to indicate matters and operations that can cause risk.  
Read the part with this symbol carefully and follow the instructions in order to avoid risk.

### **WARNING**



This indicates that the failure to follow the instructions can cause serious injury or death.

### **CAUTION**

This indicates that the failure to follow the instructions can cause the minor injury or damage to the product.

## WARNING

### Installation

-  Do not store or use flammable gas or combustibles near the unit.
  - There is risk of fire, explosion, and physical injury or death.
- An authorized, trained technician licensed locally and at the state level must install the unit.
  - Improper installation by the user may result in fire, explosion, electric shock, physical injury or death.
- Wear protective gloves when handling equipment. Sharp edges may cause personal injury.
- Always check for system refrigerant leaks after the unit has been installed or serviced.
  - Exposure to high concentration levels of refrigerant gas may lead to illness or death.
- Dispose the packing materials safely.
  - Packing materials, such as nails and other metal or wooden parts, may cause puncture wounds or other injuries. Tear apart and throw away plastic packaging bags so that children may not play with them and risk suffocation and death.
- Install the unit considering the potential for strong winds or earthquakes.
  - Improper installation may cause the unit to fall over, resulting in physical injury or death.
- Install the unit in a safe location where nobody can step on or fall onto it.  Do not install the unit on a defective stand.
  - It may result in an accident that causes physical injury or death.
- Properly insulate all cold surfaces to prevent “sweating.”
  - Cold surfaces such as uninsulated piping can generate condensate that could drip, causing a slippery surface that creates a risk of slipping, falling, and personal injury.

**(For add on heat pumps with flammable refrigerants)**

1. Instruction for installation of the critical-to-safety wiring connection of the leak detection sensor or leak detection system to the furnace assembly.
    - The wiring shall be not less than 18 AWG with a minimum insulation thickness of 1.58 mm or protected from damage. Critical-to-safety wiring is any field installed wiring necessary to fulfill the requirements of flammable refrigerant in the event of detection of a leak.
  2. Shall not be installed on furnaces with an inductive electrical greater than  $L_e$ 
    - $L_e = 5$  when breaking all phases of a three phase load
    - $L_e = 2.5$  all others
  3. Detection of a leak shall turn on the indoor fan at the highest available speed or turn it on to not less minimum air flow rate (Consult furnace manufacturer.)
- Do not use means to accelerate the defrosting process or to clean, other than those recommended by the manufacturer.
  - The appliance shall be stored in a room without continuously operating ignition sources (for example: open flames, an operating gas appliance or an operating electric heater.)
  - Do not pierce or burn.
  - Be aware that refrigerants may not contain an odour.
  - The manufacturer may provide other suitable examples or may provide additional information about the refrigerant odour.
  - Pipe-work including piping material, pipe routing, and installation shall include protection from physical damage in operation and service, and be in compliance with national and local codes and standards, such as ASHRAE 15, ASHRAE 15.2, IAPMO Uniform Mechanical Code, ICC International Mechanical Code, or CSA B52. All field joints shall be accessible for inspection prior to being covered or enclosed.
  - An unventilated area where the appliance using flammable refrigerants is installed shall be so constructed that should any refrigerant leak, it will not stagnate so as to create a fire or explosion hazard.

- Field-made refrigerant joints indoors shall be tightness tested. The test method shall have a sensitivity of 5 grams per year of refrigerant or better under a pressure of at least 0,25 times the maximum allowable pressure. No leak shall be detected;
- If appliances connected via an air duct system to one or more rooms with A2L REFRIGERANTS are installed in a room with an area less than  $A_{min}$  as determined in standard, that room shall be without continuously operating open flames (e.g. an operating gas appliance) or other POTENTIAL IGNITION SOURCES (for e.g., an operating electric heater, hot surfaces). A flame-producing device may be installed in the same space if the device is provided with an effective flame arrest.
- After completion of field piping for split systems, the field pipework shall be pressure tested with an inert gas and then vacuum tested prior to refrigerant charging, according to the following requirements:
  - The minimum test pressure for the low side of the system shall be the low side design pressure and the minimum test pressure for the high side of the system shall be the high side design pressure, unless the high side of the system, cannot be isolated from the low side of the system in which case the entire system shall be pressure tested to the low side design pressure.
  - The test pressure after removal of pressure source shall be maintained for at least 1 h with no decrease of pressure indicated by the test gauge, with test gauge resolution not exceeding 5% of the test pressure.
  - During the evacuation test, after achieving a vacuum level specified in the manual or less, the refrigeration system shall be isolated from the vacuum pump and the pressure shall not rise above 1500 microns within 10 min. The vacuum pressure level shall be specified in the manual, and shall be the lessor of 500 microns or the value required for compliance with national and local codes and standards, which may vary between residential, commercial, and industrial buildings.

## Qualification of workers

The manual shall contain specific information about the required qualification of the working personnel for maintenance, service and repair operations. Every working procedure that affects safety means shall only be carried out by qualified person by manufacturer.

Examples for such working procedures are:

- Breaking into the refrigerating circuit;
  - Opening of sealed components;
  - Opening of ventilated enclosures.
- 
- Refrigerant tubing shall be protected or enclosed to avoid damage.
  - Flexible refrigerant connectors (such as connecting lines between the indoor and outdoor unit) that may be displaced during normal operations shall be protected against mechanical damage.
  - A brazed, welded, or mechanical connection shall be made before opening the valves to permit refrigerant to flow between the refrigerating system parts.
  - Keep any required ventilation openings clear of obstruction.
  - Mechanical connections (mechanical connectors or flared joints) shall be accessible for maintenance purposes
  - Flexible pipe elements shall be protected against mechanical damage, excessive stress by torsion, or other forces. They should be checked for mechanical damage annually.
  - Protection devices, piping and fittings shall be protected as far as possible against adverse environmental effects, for example, the danger of water collecting and freezing in relief pipes or the accumulation of dirt and debris.
  - Precautions shall be taken to avoid excessive vibration or pulsation to refrigerating piping.
  - Piping in refrigerating systems shall be so designed and installed to minimize the likelihood hydraulic shock damaging the system.
  - Provision shall be made for expansion and contraction of long runs of piping.

- Steel pipes and components shall be protected against corrosion with a rustproof coating before applying any insulation.
- Auxiliary devices which can be potential ignition source shall not be installed in connecting ductwork. Examples of potential ignition sources are UV lights, electric heaters with a temperature exceeding 700 °C, pilot flames, brushed motors and similar devices.

**! NOTE**

- ☒ Do not install the product where it is exposed directly to ocean winds.
  - Sea salt in the air may cause the product to corrode. Corrosion, particularly on the condenser and evaporator fins, could cause product malfunction or inefficient operation.
- Properly insulate all cold surfaces to prevent “sweating”.
  - Cold surfaces such as uninsulated piping can generate condensate that may drip and cause a slippery surface condition and / or water damage to interior surfaces.
- Always check for system refrigerant leaks after the unit has been installed.
  - Low refrigerant levels may cause product failure.
- ☒ Do not make refrigerant substitutions. Use R32 only.
  - If a different refrigerant is used, or air mixes with original refrigerant, the unit will malfunction and be damaged.
- Keep the unit upright during installation to avoid vibration or water leakage.
- When connecting refrigerant tubing, remember to allow for pipe expansion.
  - Improper piping may cause refrigerant leaks and system malfunction.
- ☒ Do not install the outdoor unit in a noise-sensitive area. Periodically check that the outdoor frame is not damaged.
  - There is a risk of equipment damage.
- Install the unit in a safe location where nobody can step on or fall onto it. ☒ Do not install the unit on a defective stand.
  - There is a risk of unit and property damage.
- Install the drain hose to ensure adequate drainage.
  - There is a risk of water leakage and property damage.
- ☒ Do not store or use flammable gas / combustibles near the unit.
  - There is a risk of product failure.

## Wiring

- High voltage electricity is required to operate this system. Adhere to applicable building codes: National Electrical Code (NEC) for U.S. and Mexico, Canada Electrical Code (CE) for Canada and these instructions when wiring.
  - Improper connections and inadequate grounding can cause accidental injury or death.
- Always ground the unit following local, state, and national Codes.
  - There is risk of fire, electric shock, and physical injury or death.
- Properly size all circuit breakers or fuses.
  - There is risk of fire, electric shock, explosion, physical injury or death.
- The information contained in this manual is intended for use by an industry-qualified, experienced, certified electrician familiar with NEC for U.S. and Mexico, or CE for Canada who is equipped with the proper tools and test instruments.
  - Failure to carefully read and follow all instructions in this manual can result in equipment malfunction, property damage, personal injury or death.
- Refer to local, state, and federal codes, and use power wires of sufficient current capacity and rating.
  - Wires that are too small may generate heat and cause a fire.
- All electric work must be performed by a licensed electrician and conform to local building codes or, in the absence of local codes, with NEC for U.S. and Mexico, or CE for Canada, and the instructions given in this manual.
  - If the power source capacity is inadequate or the electric work is not performed properly, it may result in fire, electric shock, physical injury or death.
- Secure all field wiring connections with appropriate wire strain relief.
  - Improperly securing wires will create undue stress on equipment power lugs. Inadequate connections may generate heat, cause a fire and physical injury or death.

- Properly tighten all power lugs.
  - Loose wiring may overheat at connection points, causing a fire, physical injury or death.
- ⚠ Do not change the settings of the protection devices.
  - If the pressure switch, thermal switch, or other protection devices are bypassed or forced to work improperly, or parts other than those specified by LG are used, there is risk of fire, electric shock, explosion, and physical injury or death.
- The appliance shall be installed in accordance with national wiring regulations.
- Means for disconnection must be incorporated in the fixed wiring in accordance with the wiring rules.
- If the supply cord is damaged, it must be replaced by the manufacturer, its service agent or similarly qualified persons in order to avoid a hazard.

**! NOTE**

- ⚠ Do not supply power to the unit until all electrical wiring, controls wiring, piping, installation, and refrigerant system evacuation are completed.

## Operation

- The appliance shall be stored so as to prevent mechanical damage from occurring.
- This appliance is not intended for use by persons (including children) with reduced physical, sensory or mental capabilities or lack of experience and knowledge, unless they have been given supervision or instruction concerning use of the appliance by a person responsible for their safety. Children should be supervised to ensure that they do not play with the appliance.
- LEAK DETECTION SYSTEM installed. Unit must be powered except for service. This unit is equipped with a refrigerant leak detector for safety. To be effective, the unit must be electrically powered at all times after installation, other than when servicing. (LEAK DETECTION SYSTEM can be installed optionally for the safety purpose.)

## Service & Installation

### **Checks to the area**

Prior to beginning work on systems containing flammable refrigerants, safety checks are necessary to ensure that the risk of ignition is minimised. For repair to the refrigerating system, the following precautions shall be complied with prior to conducting work on the system.

### **Work procedure**

Work shall be undertaken under a controlled procedure so as to minimise the risk of a flammable gas or vapour being present while the work is being performed.

### **General work area**

All maintenance staff and others working in the local area shall be instructed on the nature of work being carried out. Work in confined spaces shall be avoided.

## Checking for presence of refrigerant

The area shall be checked with an appropriate refrigerant detector prior to and during work, to ensure the technician is aware of potentially flammable atmospheres. Ensure that the leak detection equipment being used is suitable for use with flammable refrigerants, i.e. non-sparking, adequately sealed or intrinsically safe.

## Presence of fire extinguisher

If any hot work is to be conducted on the refrigerating equipment or any associated parts, appropriate fire extinguishing equipment shall be available to hand. Have a dry powder or CO<sub>2</sub> fire extinguisher adjacent to the charging area.

## No ignition sources

No person carrying out work in relation to a refrigerating system which involves exposing any pipe work shall use any sources of ignition in such a manner that it may lead to the risk of fire or explosion.

All possible ignition sources, including cigarette smoking, should be kept sufficiently far away from the site of installation, repairing, removing and disposal, during which refrigerant can possibly be released to the surrounding space. Prior to work taking place, the area around the equipment is to be surveyed to make sure that there are no flammable hazards or ignition risks. "No Smoking" signs shall be displayed.

## Ventilated area

Ensure that the area is in the open or that it is adequately ventilated before breaking into the system or conducting any hot work. A degree of ventilation shall continue during the period that the work is carried out.

The ventilation should safely disperse any released refrigerant and preferably expel it externally into the atmosphere.

## Checks to the refrigerating equipment

Where electrical components are being changed, they shall be fit for the purpose and to the correct specification.

At all times the manufacturer's maintenance and service guidelines shall be followed. If in doubt consult the manufacturer's technical department for assistance.

The following checks shall be applied to installations using flammable refrigerants:

- The actual refrigerant charge is in accordance with the room size within which the refrigerant containing parts are installed
- The ventilation machinery and outlets are operating adequately and are not obstructed
- If an indirect refrigerating circuit is being used, the secondary circuit shall be checked for the presence of refrigerant
- Marking to the equipment continues to be visible and legible. Markings and signs that are illegible shall be corrected
- Refrigerating pipe or components are installed in a position where they are unlikely to be exposed to any substance which may corrode refrigerant containing components, unless the components are constructed of materials which are inherently resistant to being corroded or are suitably protected against being so corroded.

## Checks to electrical devices

Repair and maintenance to electrical components shall include initial safety checks and component inspection procedures. If a fault exists that could compromise safety, then no electrical supply shall be connected to the circuit until it is satisfactorily dealt with. If the fault cannot be corrected immediately but it is necessary to continue operation, an adequate temporary solution shall be used. This shall be reported to the owner of the equipment so all parties are advised.

Initial safety checks shall include:

- Capacitors are discharged: this shall be done in a safe manner to avoid possibility of sparking.
- No live electrical components and wiring are exposed while charging, recovering or purging the system.
- Continuity of earth bonding

## **Repairs to sealed components**

Sealed electrical components shall be replaced.

## **Repair to intrinsically safe components**

Intrinsically safe components must be replaced.

## **Cabling**

Check that cabling will not be subject to wear, corrosion, excessive pressure, vibration, sharp edges or any other adverse environmental effects. The check shall also take into account the effects of aging or continual vibration from sources such as compressors or fans.

## **Detection of flammable refrigerants**

Under no circumstances shall potential sources of ignition be used in the searching for or detection of refrigerant leaks. A halide torch (or any other detector using a naked flame) shall not be used.

## **Leak detection methods**

The following leak detection methods are deemed acceptable for all refrigerant systems.

Electronic leak detectors may be used to detect refrigerant leaks but, in the case of FLAMMABLE REFRIGERANTS, the sensitivity may not be adequate, or may need re-calibration. (Detection equipment shall be calibrated in a refrigerant-free area.) Ensure that the detector is not a potential source of ignition and is suitable for the refrigerant used. Leak detection equipment shall be set at a percentage of the LFL of the refrigerant and shall be calibrated to the refrigerant employed, and the appropriate percentage of gas (25 % maximum) is confirmed.

Leak detection fluids are also suitable for use with most refrigerants but the use of detergents containing chlorine shall be avoided as the chlorine may react with the refrigerant and corrode the copper pipe-work.

**! NOTE****Examples of leak detection fluids are**

- Bubble method
- Fluorescent method agents

If a leak is suspected, all naked flames shall be removed / extinguished.

If a leakage of refrigerant is found which requires brazing, all of the refrigerant shall be recovered from the system, or isolated (by means of shut off valves) in a part of the system remote from the leak. Removal of refrigerant shall be according to removal and evacuation procedure.

**Removal and evacuation**

When breaking into the refrigerant circuit to make repairs – or for any other purpose – conventional procedures shall be used. However, for flammable refrigerants it is important that best practice be followed, since flammability is a consideration.

The following procedure shall be adhered to:

- Safely remove refrigerant following local and national regulations;
- Evacuate;
- Purge the circuit with inert gas (optional for A2L);
- Evacuate (optional for A2L);
- Continuously flush or purge with inert gas when using flame to open circuit; and
- Open the circuit.

The refrigerant charge shall be recovered into the correct recovery cylinders if venting is not allowed by local and national codes. For appliances containing flammable refrigerants, the system shall be purged with oxygen-free nitrogen to render the appliance safe for flammable refrigerants. This process might need to be repeated several times.

Compressed air or oxygen shall not be used for purging refrigerant systems.

For appliances containing flammable refrigerants, refrigerants purging shall be achieved by breaking the vacuum in the system with oxygen-free nitrogen and continuing to fill until the working pressure is achieved, then venting to atmosphere, and finally pulling down to a vacuum (optional for A2L). This process shall be repeated until no refrigerant is within the system (optional for A2L). When the final oxygen-free nitrogen charge is used, the system shall be vented down to atmospheric pressure to enable work to take place.

The outlet for the vacuum pump shall not be close to any potential ignition sources, and ventilation shall be available.

### **Charging procedures**

In addition to conventional charging procedures, the following requirements shall be followed.

- Ensure that contamination of different refrigerants does not occur when using charging equipment. Hoses or lines shall be as short as possible to minimise the amount of refrigerant contained in them.
- Cylinders shall be kept in an appropriate position according to the instruction.
- Ensure that the refrigerating system is earthed prior to charging the system with refrigerant.
- Label the system when charging is complete (if not already).
- Extreme care shall be taken not to overfill the refrigerating system.

Prior to recharging the system, it shall be pressure tested with the appropriate purging gas.

The system shall be leak-tested on completion of charging but prior to commissioning. A follow up leak test shall be carried out prior to leaving the site.

## Decommissioning

Before carrying out this procedure, it is essential that the technician is completely familiar with the equipment and all its detail.

It is recommended good practice that all refrigerants are recovered safely.

Prior to the task being carried out, an oil and refrigerant sample shall be taken in case analysis is required prior to re-use of recovered refrigerant.

It is essential that electrical power is available before the task is commenced.

- a) Become familiar with the equipment and its operation.
- b) Isolate system electrically.
- c) Before attempting the procedure ensure that:
  - Mechanical handling equipment is available, if required, for handling refrigerant cylinders
  - All personal protective equipment is available and being used correctly
  - The recovery process is supervised at all times by a competent person
  - Recovery equipment and cylinders conform to the appropriate standards.
- d) Pump down refrigerant system, if possible.
- e) If a vacuum is not possible, make a manifold so that refrigerant can be removed from various parts of the system.
- f) Make sure that cylinder is situated on the scales before recovery takes place.
- g) Start the recovery machine and operate in accordance with instructions.
- h) Do not overfill cylinders. (No more than 80 % volume liquid charge).
- i) Do not exceed the maximum working pressure of the cylinder, even temporarily.
- j) When the cylinders have been filled correctly and the process completed, make sure that the cylinders and the equipment are removed from site promptly and all isolation valves on the equipment are closed off.

- k) Recovered refrigerant shall not be charged into another refrigerating system unless it has been cleaned and checked.

### Labelling

Equipment shall be labelled stating that it has been de-commissioned and emptied of refrigerant.

The label shall be dated and signed.

Ensure that there are labels on the equipment stating the equipment contains flammable refrigerant.

### Recovery

When removing refrigerant from a system, either for servicing or decommissioning, it is recommended good practice that all refrigerants are removed safely.

When transferring refrigerant into cylinders, ensure that only appropriate refrigerant recovery cylinders are employed.

Ensure that the correct number of cylinders for holding the total system charge is available.

All cylinders to be used are designated for the recovered refrigerant and labelled for that refrigerant (i.e. special cylinders for the recovery of refrigerant).

Cylinders shall be complete with pressure-relief valve and associated shut-off valves in good working order.

Empty recovery cylinders are evacuated and, if possible, cooled before recovery occurs.

The recovery equipment shall be in good working order with a set of instructions concerning the equipment that is at hand and shall be suitable for the recovery of the flammable refrigerant.

If in doubt, the manufacturer should be consulted. In addition, a set of calibrated weighing scales shall be available and in good working order.

Hoses shall be complete with leak-free disconnect couplings and in good condition.

The recovered refrigerant shall be processed according to local legislation in the correct recovery cylinder, and the relevant waste transfer note arranged.

Do not mix refrigerants in recovery units and especially not in cylinders.

If compressor or compressor oils are to be removed, ensure that they have been evacuated to an acceptable level to make certain that flammable refrigerant does not remain within the lubricant.

The compressor body shall not be heated by an open flame or other ignition sources to accelerate this process.

When oil is drained from a system, it shall be carried out safely.

## CAUTION

### Installation

- Be very careful when transporting the product. There is a risk of the product falling and causing physical injury.
  - Use appropriate moving equipment to transport each frame; ensure the equipment is capable of supporting the weight of the equipment.
- The Limited Warranty is void and of no effect, and LG will have no liability hereunder to any Customer or third party, to the extent any of the following occur: acts, omissions, and conduct of any and all third parties including, but not limited to, the installing contractor and any repairs, service or maintenance by unauthorized or unqualified persons.
- Do not insert a drain hose in drain pipe or sewer pipe.
  - Bad smells can occur and it results in a corrosion of a heat exchanger or pipe.
- Do not install the unit in potentially explosive atmospheres.
- The installation of pipe-work shall be kept to a minimum
- Any person who is involved with working on or breaking into a refrigerant circuit should hold a current valid certificate from an industry-accredited assessment authority, which authorises their competence to handle refrigerants safely in accordance with an industry recognised assessment specification.
- When mechanical connectors are reused indoors, sealing parts shall be renewed.
- When flared joints are reused indoors, the flare part shall be re-fabricated.

## Operation

- This appliance is not intended for the purposes of cooling INFORMATION TECHNOLOGY EQUIPMENT
- Servicing shall only be performed as recommended by the equipment manufacturer. Maintenance and repair requiring the assistance of other skilled personnel shall be carried out under the supervision of the person competent in the use of flammable refrigerants.

## Service

- Servicing shall be performed only as recommended by the manufacturer.

---

# TABLE OF CONTENTS

## 2 SAFETY INSTRUCTIONS

---

## 23 INSTALLATION OF OUTDOOR UNIT

---

- 23 Select the best location
- 27 Piping length and elevation

## 29 FLARING WORK AND CONNECTION OF PIPING

---

- 29 Flaring work
- 30 Nitrogen substitution method
- 31 Connection of piping - Outdoor
- 35 Installation of the BD Unit

## 38 CONNECTING THE CABLE BETWEEN INDOOR UNIT, DISTRIBUTOR UNIT AND OUTDOOR UNIT

---

- 38 Connect the cable to the Indoor unit
- 41 Connect the cable to the Distributor unit
- 43 Connect the cable to the Outdoor unit
- 45 Connection method of the connecting cable (Example)

## 47 CHECKING THE DRAINAGE, INSULATING THE PIPE AND SPECIAL PIPING APPLICATIONS

---

- 47 Checking the drainage
- 47 Insulating the Pipe and Special Piping Applications

## 48 AIR PURGING AND EVACUATION

---

- 48 Leak Checking
- 49 Evacuation

## 50 CHARGING

---

## **54 CHECKING THE SETTING OF OUTDOOR UNIT**

---

- 56 Manual Pipe Detection Process (Multi F and Multi F with LGRED®)
- 57 Auto Pipe Detection Process (Multi F and Multi F with LGRED®)
- 58 Manual Pipe Detection Process (Multi F MAX and Multi F MAX with LGRED®)
- 59 Auto Pipe Detection Process (Multi F MAX and Multi F MAX with LGRED®)

## **60 PIPING ADDRESS SETTING WITH REMOTE CONTROLLER**

---

- 60 Wireless remote controller
- 61 Standard 3 Wired remote controller

## **62 TEST RUNNING**

---

## **63 FUNCTION**

---

- 63 DIP S/W Setting
- 64 Forced Cooling Operation
- 64 Saving Power Consumption
- 65 Night Quiet Mode
- 65 Mode Lock

## **66 MAX COMBINATION CAPACITY**

---

## **67 INSTALLATION GUIDE AT THE SEASIDE**

---

## **68 SEASONAL WIND AND CAUTIONS IN WINTER**

---

# INSTALLATION OF OUTDOOR UNIT

Read completely, then follow step by step.

You need to select adequate installation location

considering the following conditions, and make sure to acquire the consent of the user.

## Select the best location

### Outdoor unit

- 1 If an awning is built over the unit to prevent direct sunlight or rain exposure, make sure that heat radiation from the condenser is not restricted.
- 2 Ensure that the spaces indicated by arrows around front, back and side of the unit.
- 3 Do not place animals and plants in the path of the warm air.
- 4 Take the air conditioner weight into account and select a place where noise and vibration are minimum.
- 5 Select a place so that the warm air and noise from the air conditioner do not disturb neighbors.
- 6 Place that can sufficiently endure the weight and vibration of the outdoor unit and where even installation is possible.
- 7 Place that has no direct influence of snow or rain.
- 8 Place with no danger of snowfall or icicle drop.
- 9 Place without weak floor or base such as decrepit part of the building or with a lot of snow accumulation.
- 10 Sufficient ventilation is secured.
- 11 Ensure that the coil side of the outdoor unit is installed no less than 300 mm (11 13/16 inch) close to a structure to allow for access to the rear viewing window.

Multi F / Multi F LGRED Outdoor Unit Service Access and Allowable Clearances.

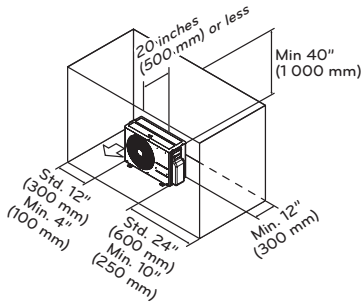

Obstacles above and on the air discharge side.

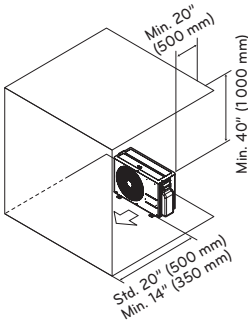

Where there are obstacles on both suction and discharge sides (discharge side obstacle is higher than the outdoor unit).

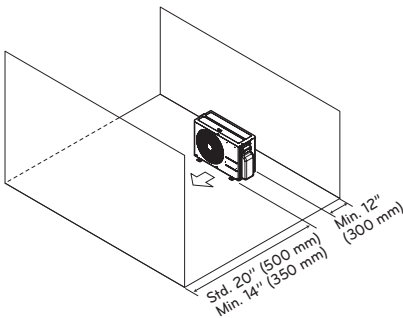

Series installation.

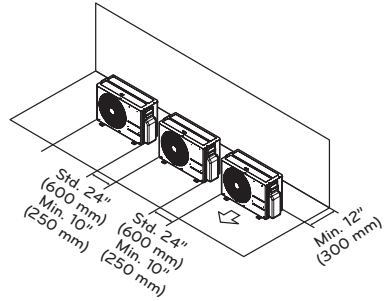
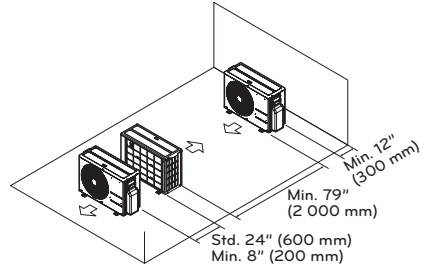

**NOTE**

- Ensure that the coil side of the outdoor unit is installed no less than 300 mm (12 inch) close to a structure to allow for access to the rear viewing window.
- If the outdoor unit is installed between standard and minimum clearances, capacity decreases approximately 10%.

**Multi F MAX / Multi F MAX LGRED® Outdoor Unit Service Access and Allowable Clearances.**

Obstacles on the suction side and on both left and right sides.

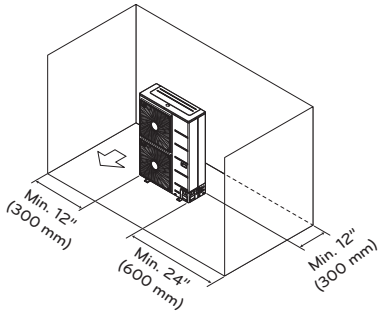

Where there are obstacles on both suction and discharge sides (discharge side obstacle is higher than the outdoor unit).

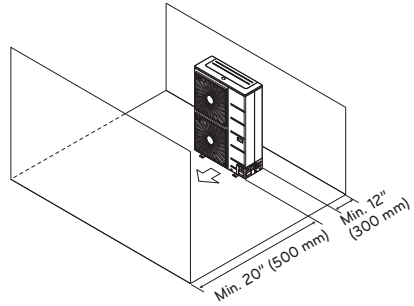

Obstacles above, on the air intake side, and on both left and right sides.

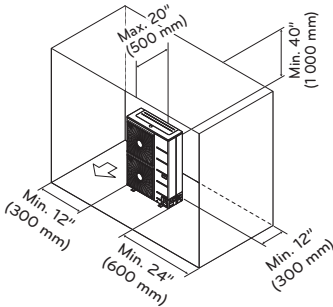

Obstacles above and on the air discharge side.

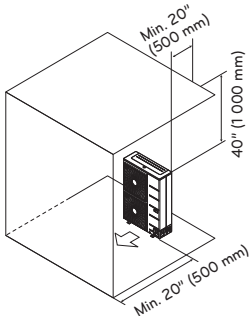

**! NOTE**

- Ensure that the coil side of the outdoor unit is installed no less than 300 mm (12 inch) close to a structure to allow for access to the rear viewing window.
- If the outdoor unit is installed under the minimum clearances, capacity decreases more than 10%.

**! NOTE**

“L” must be lower than “H”. If a stand is necessary, it must be contained (not open frame) to prevent the discharge air from short cycling.

Where there are obstacles above, and on both suction and discharge sides (discharge side obstacle is lower than the outdoor unit).

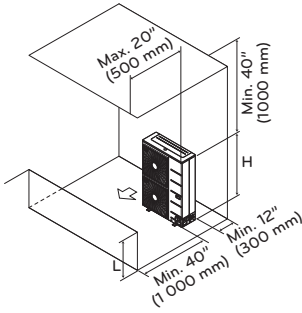

Ratio among H, A, and L.

	L	A
$L \leq H$	$0 < L \leq 1/2 H$	30 inches (750 mm)
	$1/2 H < L$	40 inches (1 000 mm)
$H < L$	Set Stand as: $L \leq H$	

Side-by-side series installation.

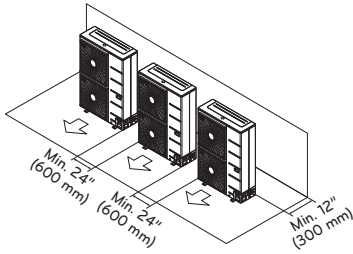

Series installation.

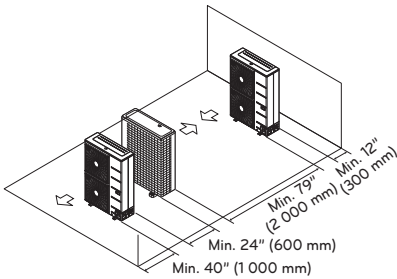

## Piping length and elevation

### Multiple Piping Models (Multi F)

(Unit: m (ft))

Outdoor Unit Capacity (kBtu/h class)	Max total length of all pipes (A+B)/(A+B+C)/(A+B+C+D)	Max length of each pipe (A/B/C/D)	Min length of each pipe (A/B/C/D)	Max Elevation between each indoor unit and outdoor unit (h1)	Max elevation between indoor units (h2)	Max. Combination of Indoor unit (kBtu/h class)
18	50 (164.0)	25 (82.0)	3 (9.8)	15 (49.2)	7.5 (24.6)	24
24	70 (229.7)	25 (82.0)	3 (9.8)	15 (49.2)	7.5 (24.6)	33
30	75 (246.1)	25 (82.0)	3 (9.8)	15 (49.2)	7.5 (24.6)	40
36	75 (246.1)	25 (82.0)	3 (9.8)	15 (49.2)	7.5 (24.6)	48

### Multiple Piping Models (Multi F LGRED°)

(Unit: m(ft))

Outdoor Unit Capacity (kBtu/h class)	Max total length of all pipes (A+B)/(A+B+C)/(A+B+C+D)	Max length of each pipe (A/B/C/D)	Min length of each pipe (A/B/C/D)	Max Elevation between each indoor unit and outdoor unit (h1)	Max elevation between indoor units (h2)	Max. Combination of Indoor unit (kBtu/h class)
18	50 (164.0)	25 (82.0)	3 (9.8)	15 (49.2)	7.5 (24.6)	24
24	75 (246.1)	25 (82.0)	3 (9.8)	15 (49.2)	7.5 (24.6)	33
30	75 (246.1)	25 (82.0)	3 (9.8)	15 (49.2)	7.5 (24.6)	40

### Distributor Piping Models (Multi F MAX)

(Unit: m(ft))

Outdoor Unit Capacity (kBtu/h class)	Max total length of all pipes (Main + Branch pipes)	Max length of Main pipe (A+B+C)	Max length of Branch pipes	Max length of each Branch pipe	Min length of each pipe (Main / Branch pipes)	Max Elevation Between each indoor unit and outdoor unit (h1)	Max elevation between indoor units (h2)	Max. Combination of Indoor unit (kBtu/h class)
48	145 (475.7)	55 (180.4)	90 (295.3)	15 (49.2)	5 (16.4)	30 (98.4)	15 (49.2)	65
54	145 (475.7)	55 (180.4)	90 (295.3)	15 (49.2)	5 (16.4)	30 (98.4)	15 (49.2)	73
60	145 (475.7)	55 (180.4)	90 (295.3)	15 (49.2)	5 (16.4)	30 (98.4)	15 (49.2)	81

### Distributor Piping Models (Multi F MAX with LGRED°)

(Unit: m(ft))

Outdoor Unit Capacity (kBtu/h class)	Max total length of all pipes (Main + Branch pipes)	Max length of Main pipe (A+B+C)	Max length of Branch pipes	Max length of each Branch pipe	Min length of each pipe (Main / Branch pipes)	Max Elevation Between each indoor unit and outdoor unit (h1)	Max elevation between indoor units (h2)	Max. Combination of Indoor unit (kBtu/h class)
36	145 (475.7)	55 (180.4)	90 (295.3)	15 (49.2)	5 (16.4)	30 (98.4)	15 (49.2)	48
42	145 (475.7)	55 (180.4)	90 (295.3)	15 (49.2)	5 (16.4)	30 (98.4)	15 (49.2)	56
48	145 (475.7)	55 (180.4)	90 (295.3)	15 (49.2)	5 (16.4)	30 (98.4)	15 (49.2)	65

**Important:**

If you are ever uncertain of the unit charge, reclaim, evacuate and weigh in the correct charge using the charge amount specified on the Unit's specification label.

**Calculation method for total capacity index = sum up the capacity index of connected indoor units**

- Total capacity index = [Sum of all VAHU & Ceiling Concealed Duct (Mid static) type indoor units capacity (if any)] x 1.3 + Sum of all other indoor unit's capacity
- The multiplier(1.3) is only necessary for calculation of combination ratio.
- For combinations where it contains one of below conditions, multiplier is 1.2 instead of 1.3.
  - ONE 24 k high Mid static unit/VAHU AND ONE 24 k Mid static ducted unit/VAHU
  - ONE 24 k high Mid static unit/VAHU AND ONE 36 K Mid static ducted unit/VAHU

Unit : mm (inch)

Indoor unit Capacity (kBtu/h class)	Pipe Diameter	
	Gas	Liquid
7, 9, 12, 15	9.52 (3/8)	6.35 (1/4)
18, 24	12.7 (1/2)	6.35 (1/4)
30, 36	15.88 (5/8)	9.52 (3/8)

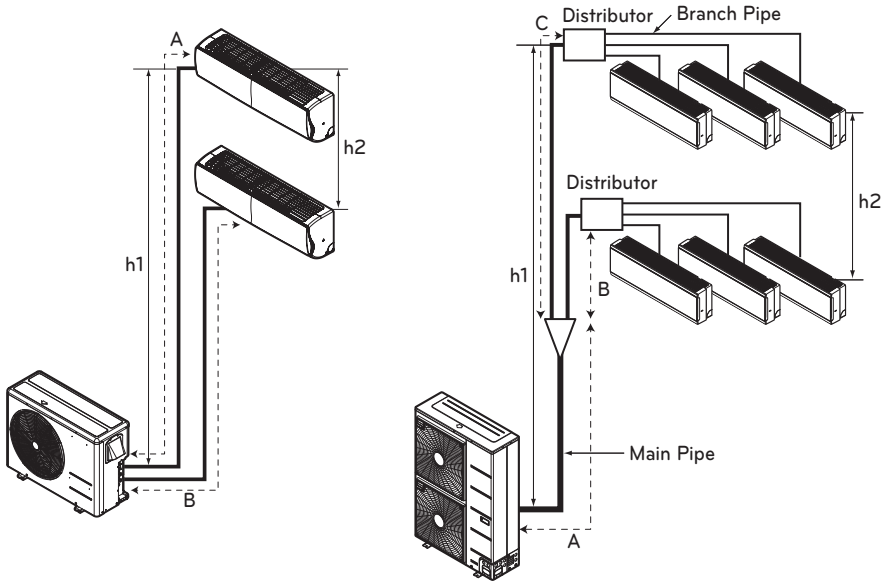

**CAUTION**

Capacity is based on standard length and maximum allowance length is on the basis of reliability.

# FLARING WORK AND CONNECTION OF PIPING

## Flaring work

Main cause of gas leakage is defect in flaring work. Carry out correct flaring work in the following procedure.

### Cut the pipes and the cable.

- Use the accessory piping kit or the pipes purchased locally.
- Measure the distance between the indoor and the outdoor unit.
- Cut the pipes a little longer than measured distance.
- Cut the cable 1.5 m (4.9 ft) longer than the pipe length.

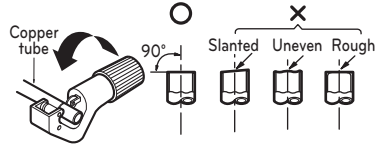

### Burrs removal

- Completely remove all burrs from the cut cross section of pipe/tube.
- Put the end of the copper tube/pipe to downward direction as you remove burrs in order to avoid to let burrs drop in the tubing.

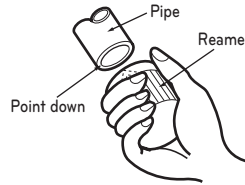

### Putting nut on

- Remove flare nuts attached to indoor and outdoor units, than put them on pipe/tube having completed burr removal. (Not possible to put them on after flaring work)

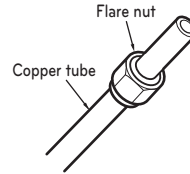

### Flaring work

- Carry out flaring work using flaring tool as shown below.

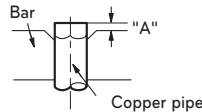

Pipe diameter Inch (mm)	A inch (mm)	
	Wing nut type	Clutch type
Ø1/4 (Ø6.35)	0.04~0.05 (1.1~1.3)	0~0.02 (0~0.5)
Ø3/8 (Ø9.52)	0.06~0.07 (1.5~1.7)	
Ø1/2 (Ø12.7)	0.06~0.07 (1.6~1.8)	
Ø5/8 (Ø15.88)	0.06~0.07 (1.6~1.8)	
Ø3/4 (Ø19.05)	0.07~0.08 (1.9~2.1)	

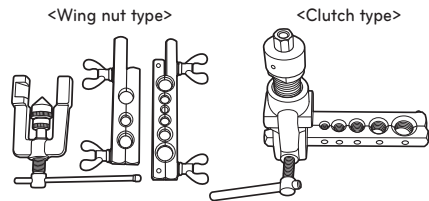

Firmly hold copper tube in a bar(or die) as indicated dimension in the table above.

### Check

- Compare the flared work with figure.
- If flare is noted to be defective, cut off the flared section and do flaring work again.

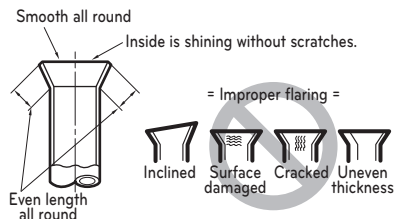

## Nitrogen substitution method

When connecting to the outdoor unit or Y-branch connections, refrigerant pipe connection must be brazed.

Welding, as when heating without nitrogen substitution a large amount of the oxide film is formed on the internal piping.

The oxide film is caused by clogging EEV, Capillary, oil hole of accumulator and suction hole of oil pump in compressor.

It prevents normal operation of the compressor.

In order to avoid this problem, Welding should be done after replacing air by nitrogen gas.

When welding plumbing pipe, the work is required.

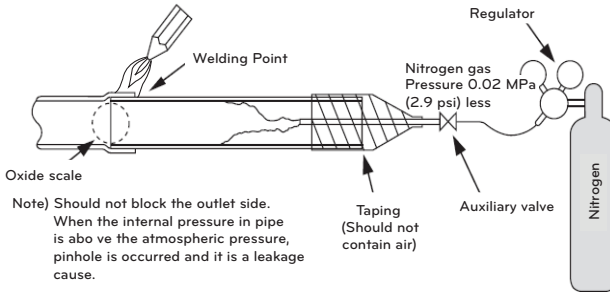

## CAUTION

- Always use the nitrogen.  
(not use oxygen, carbon dioxide, and a Chevron gas)  
Please use the following nitrogen pressure 0.02 MPa (2.9 psi)
  - Oxygen: Promotes oxidative degradation of refrigerant oil. Because it is flammable, it is strictly prohibited to use
  - Carbon dioxide: Degrade the drying characteristics of gas
  - Chevron Gas: Toxic gas occurs when exposed to direct flame.
- Always use a pressure reducing valve.
- Please do not use commercially available antioxidant.  
The residual material seems to be the oxide scale is observed. In fact, due to the organic acids generated by oxidation of the alcohol contained in the anti-oxidants, ants nest corrosion occurs. (Causes of organic acid → alcohol + copper + water + temperature)

## Connection of piping - Outdoor

Align the center of the piping and sufficiently tighten the flare nut by hand.

Connecting pipe order

- 1) ROOM A~D gas side pipe
- 2) ROOM A~D liquid side pipe

Finally, tighten the flare nut with torque wrench until the wrench clicks.

- When tightening the flare nut with torque wrench ensure the direction for tightening follows the arrow on the wrench.

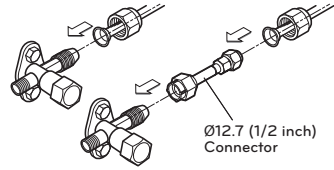

### Outdoor unit

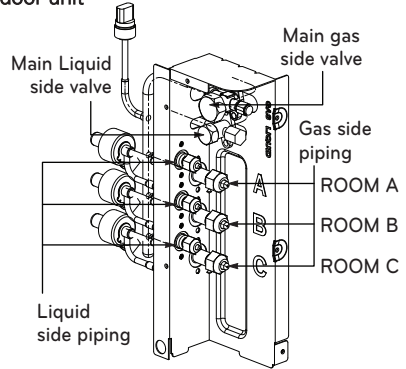

\* The figure can be changed according to model.

Outside diameter		Torque		
mm	inch	kgf·cm	N·m	lbf·ft
Ø 6.35	Ø 1/4	180 ~ 250	17.6 ~ 24.5	13 ~ 18
Ø 9.52	Ø 3/8	340 ~ 420	33.3 ~ 41.2	25 ~ 30
Ø 12.7	Ø 1/2	550 ~ 660	53.9 ~ 64.7	40 ~ 48
Ø 15.88	Ø 5/8	630 ~ 820	61.7 ~ 80.4	45 ~ 59
Ø 19.05	Ø 3/4	990 ~ 1 210	97.0 ~ 118.7	71 ~ 87

### Multi F MAX / Multi F MAX with LGRED® (BD Unit : PMBD36\*0ZR)

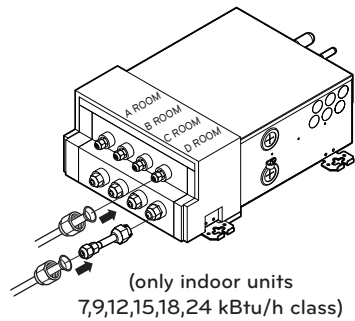

### (BD Unit : PMBD3641ZR)

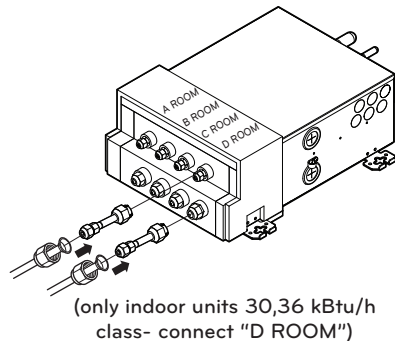

BD Unit	Refrigerant Connections Pipe Size (inch (mm))		Connectable Indoor Unit Capacity (kBTu/h class)
	Liquid	Gas	
PMBD3620ZR	1/4 (Ø 6.35) x 2 EA	3/8 (Ø 9.52) x 2 EA	7,9,12,15, 18,24 k
PMBD3630ZR	1/4 (Ø 6.35) x 3 EA	3/8 (Ø 9.52) x 3 EA	7,9,12,15, 18,24 k
PMBD3640ZR	1/4 (Ø 6.35) x 4 EA	3/8 (Ø 9.52) x 4 EA	7,9,12,15, 18,24 k
PMBD3641ZR	1/4 (Ø 6.35) x 4 EA	3/8 (Ø 9.52) x 3 EA	7,9,12,15, 18,24 k (A,B,C ROOM)
		1/2 (Ø 12.7) x 1 EA	30,36 k (D ROOM)

\* BD Unit(PMBD3641ZR) includes the socket.  
 (1/2(Ø 12.7) → 5/8(Ø 15.88) x 1 EA,  
 1/4(Ø 6.35) → 3/8(Ø 9.52) x 1 EA)

- For the units of Distributor Piping Type, the installation piping is connectable in four directions.(refer to figure 1)
- When connecting in a downward direction, knock out the knockout hole of the base pan. (refer to figure 2)

**Preventing foreign objects from entering (Figure3)**

- Plug the pipe through-holes with putty or insulation material(procured locally)to stop up all gaps, as shown in the figure 3.
- Insects or small animals entering the outdoor unit may cause a short circuit in the electrical box.

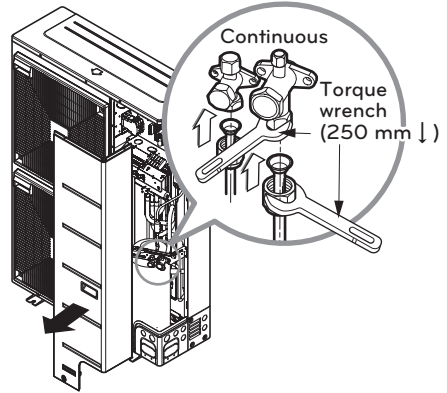

\* When tighten the pipe, hold the hexagonal body.

<Figure 1>

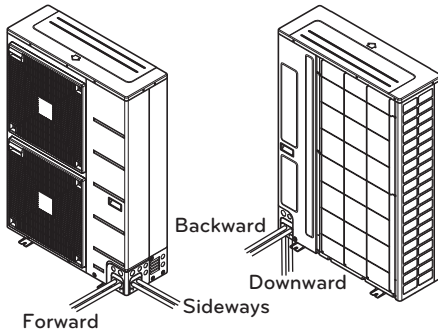

<Figure 3>

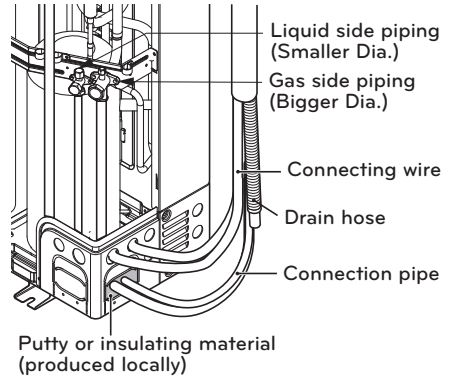

<Figure 2>

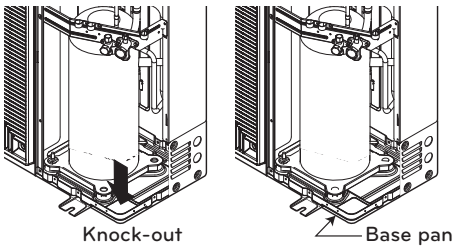

- Align the center of the piping and sufficiently tighten the flare nut by hand.
- Finally, tighten the flare nut with torque wrench until the wrench clicks. When tightening the flare nut with torque wrench, ensure the direction for tightening follows the arrow on the wrench.

Outside diameter		Torque		
mm	inch	kgf-cm	N-m	lbf-ft
Ø 6.35	Ø 1/4	180 ~ 250	17.6 ~ 24.5	13 ~ 18
Ø 9.52	Ø 3/8	340 ~ 420	33.3 ~ 41.2	25 ~ 30
Ø 12.7	Ø 1/2	550 ~ 660	53.9 ~ 64.7	40 ~ 48
Ø 15.88	Ø 5/8	630 ~ 820	61.7 ~ 80.4	45 ~ 59
Ø 19.05	Ø 3/4	990 ~ 1 210	97.0 ~ 118.7	71 ~ 87

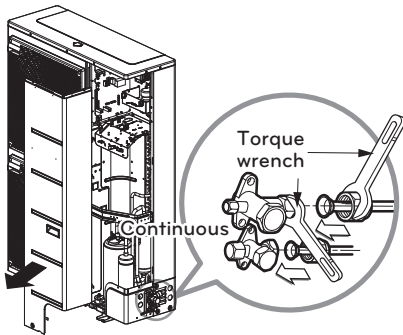

\* When tighten the pipe, hold the hexagonal body.

### Preventing foreign objects from entering (Figure1)

- Plug the pipe through-holes with putty or insulation material (procured locally) to stop up all gaps, as shown in the figure 1.

<Figure 1>

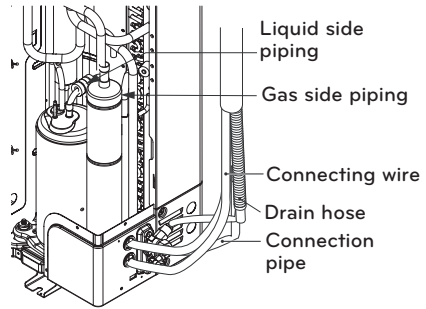

### CAUTION

- Insects or small animals entering the outdoor unit may cause a short circuit in the electrical box.

Branch

[Unit : mm(inch)]

Models	Low Pressure Gas Pipe	Liquid pipe
ARBLB03321		

Y branch

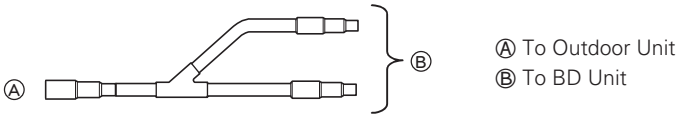

Ensure that the branch pipes are attached horizontally or vertically (see the diagram below.)

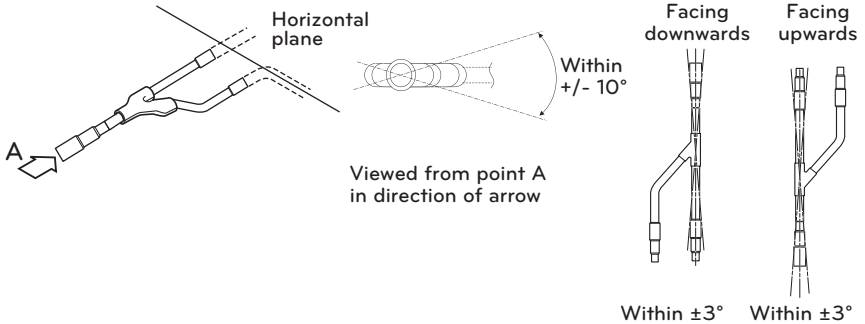

Branch pipe should be insulated with the insulator in each kit.

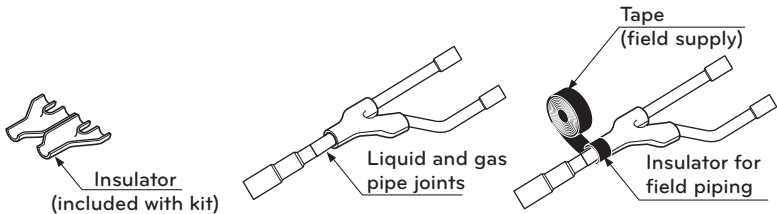

\* For more information, refer accessory installation manual.

## Installation of the BD Unit

- This unit may be installed suspended from the ceiling or mounted on the wall.
- This unit may be installed horizontally, as shown in the diagram below. (Side B is facing up) However, it may be freely installed in any direction forward or back, and to the sides.
- Be sure to leave a 23.6 inch square opening for service and inspection as shown in the diagram below, for both ceiling - suspended installation and wall-mounted installation.
- This unit "does not require drain treatment" as it uses internal foam treatment as low-pressure piping insulation.
- Service direction is the side B and C
- The piping for the indoor unit may be led around in direction A
- The inclination of side B must be within  $\pm 5$  degrees forward or back or to the sides.

(Unit : mm (inch))

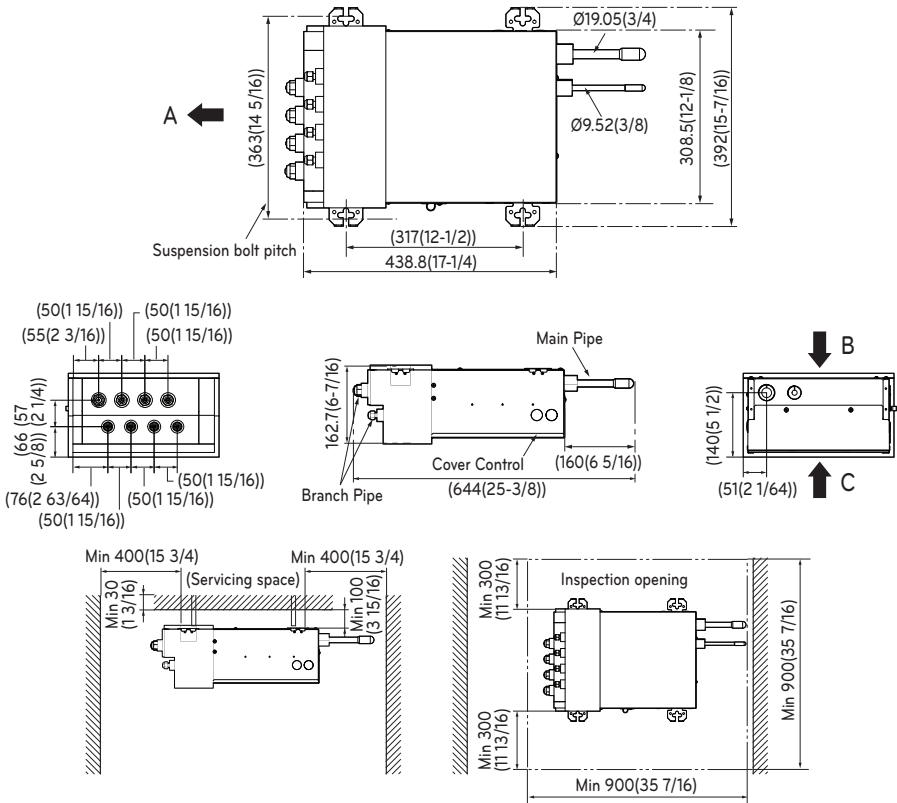

**! NOTE**

- This unit has two different installation types: ① Ceiling-suspended type and ② wall-mounted type.

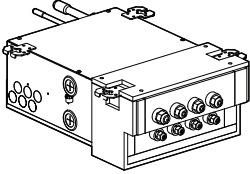

① Ceiling-suspended type

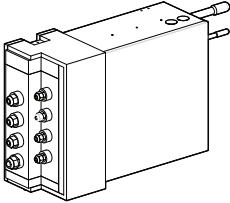

② Wall-mounted type

- Choose the proper installation pattern according to the location of installation.

**Ceiling-suspended type**

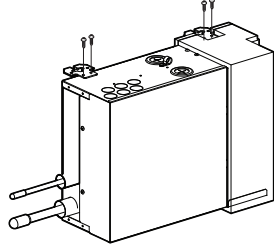
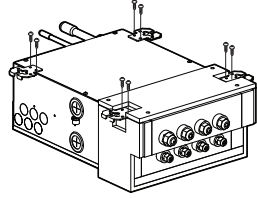

**Wall-mounted type**

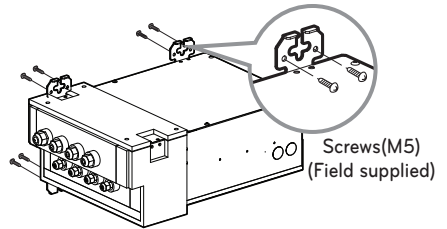

## Procedure

- Fix the furnished hanger metal with two screws.(4 locations in total).
- Using an insert-hole-in- anchor, hang the hanging bolt.
- Install a hexagon nut and a flat washer (locally-procured)to the hanging bolt as shown in the figure in the left, and lift the main unit to hang on the hanger metal.
- After checking with a level that the unit is level, tighten the hexagon nut.
- \* The tilt of the unit should be within  $\pm 5^\circ$  in front/back and left/right.

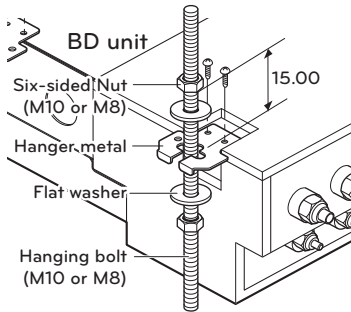

- Fix the furnished hanger metal with two screws. (3 locations in total).
- After checking with a level that the unit is level, fix the unit with the furnished wood screws.
- \* The tilt of the unit should be within  $\pm 5^\circ$  in front/back and left/right.
- \* Block up the parts of hanger holes (2 places) by using insulation PE after installing the hanger.

## CAUTION

- Once a screw-hole on the main unit has had a screw hammered in, make sure to either hammer it again or cover it with aluminum tape.(This is to prevent condensation)
- Be sure to install the unit with the ceiling-side up.
- Do not install near bedrooms. the sound of refrigerant flowing through the piping may sometimes be audible.

# CONNECTING THE CABLE BETWEEN INDOOR UNIT, DISTRIBUTOR UNIT AND OUTDOOR UNIT

## Connect the cable to the Indoor unit

Connect the cable to the indoor unit by connecting the wires to the terminals on the control board individually according to the outdoor unit connection. (Ensure that the color of the wires of the outdoor unit and the terminal No. are the same as those of the indoor unit.)

The ground wire should be longer than the common wires.

The circuit diagram is not subject to change without notice.

When installing, refer to the electrical diagram behind the front panel of Indoor Unit.

The wiring for the outdoor unit can be found on the inside of the Outdoor Unit control cover.

Pipes and wires should be purchased separately for installation of the product.

### ⚡ RECOMMENDATION

- The circuit diagram is subject to change without notice.
- Be sure to connect wires according to the wiring diagram.
- Connect the wires firmly, so that they can not be pulled out easily.
- Connect the wires according to color codes by referring to the wiring diagram.

### ⚡ RECOMMENDATION

Provide a circuit breaker between power source and the outdoor unit as shown below.

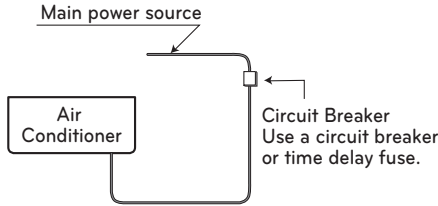

#### Multi F

Outdoor Unit Capacity (kBTu/h class)	Power source	Fuse or breaker Capacity
18, 24	1Ø, 208/230 V	20 A
30, 36	1Ø, 208/230 V	25 A

#### Multi F LGRED°

Outdoor Unit Capacity (kBTu/h class)	Power source	Fuse or breaker Capacity
18, 24, 30	1Ø, 208/230 V	30 A

#### Multi F MAX

Outdoor Unit Capacity (kBTu/h class)	Power source	Fuse or breaker Capacity
48, 54, 60	1Ø, 208/230 V	40 A

#### Multi F MAX with LGRED°

Outdoor Unit Capacity (kBTu/h class)	Power source	Fuse or breaker Capacity
36, 42, 48	1Ø, 208/230 V	40 A

**RECOMMENDATION**

The power cord connected to the outdoor unit should comply with the following specifications: NRTL Recognized (for example, UL or ETL recognized and CSA certified).

As always, final wire selection is governed by local codes and should be installed by a licensed professional contractor.

**[Power supply cable]**

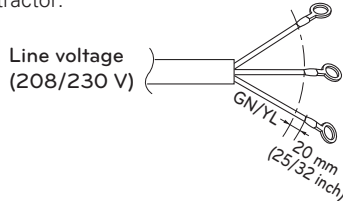

**Multi F**

Outdoor Unit Capacity (kBtu/h class)	The minimum recommended wire size
18, 24	AWG 14-3
30, 36	AWG 12-3

**Multi F LGRED°**

Outdoor Unit Capacity (kBtu/h class)	The minimum recommended wire size
18, 24, 30	AWG 12-3

**Multi F MAX**

Outdoor Unit Capacity (kBtu/h class)	The minimum recommended wire size
48, 54, 60	AWG 8-3

**Multi F MAX with LGRED°**

Outdoor Unit Capacity (kBtu/h class)	The minimum recommended wire size
36, 42, 48	AWG 8-3

Please refer to the instructions below for proper installation.

- Power wiring/power wiring gauge to the outdoor unit(s) must be solid or stranded and must comply with all National Electrical Code (NEC), UL, and local electrical codes.
- Power wiring cable from the outdoor unit to the indoor unit must be a minimum of 14 AWG, 3-conductor, solid core or stranded, rated for 600 V.
- Communication wiring cable from the outdoor unit to the indoor unit must be minimum 18 AWG, 2-conductor, twisted, stranded, and shielded (shield must be grounded to the outdoor unit chassis only).

**[Connecting cable]**

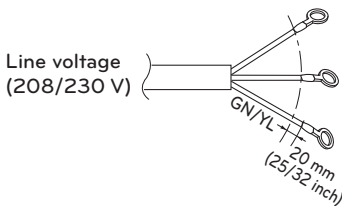

Power supply cable

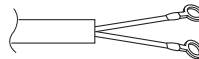

Communication cable

**RECOMMENDATION**

When using separate wires as the power cord, please secure separate wires in the control box panel using tie wraps to hold all wires in place.

### Precautions when laying power and ground wiring

Use round pressure terminals for connections to the power terminal block.

When laying ground wiring, you must use round pressure terminals.

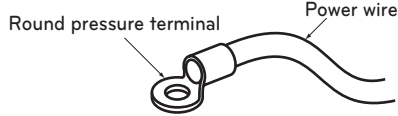

When none are available, follow the instructions below.

- Do not connect wiring of different thicknesses to the power terminal block. (Slack in the power wiring may cause abnormal heat.)
- When connecting wiring which is the same thickness, do as shown in the figure below.



- For wiring, use the designated power wire and connect firmly, then secure to prevent outside pressure being exerted on the terminal block.
- Use an appropriate screwdriver for tightening the terminal screws. A screwdriver with a small head will strip the head and make proper tightening impossible.
- Over-tightening the terminal screws may break them.

## Connect the cable to the Distributor unit

- Connect refrigerant pipes and connection wires to the appropriate ports marked with matching alphabets (A, B and C) on this unit.
- Follow the instructions on the wiring nameplate to connect the connection wires of indoor/outdoor units to terminal board numbers.(1, 2 and 3) Always fix each ground wire separately with a ground screw.(See the figure below.)
- After completing the wiring, fix the outer coating of wires securely with wire clamps. The wire clamp on indoor unit side is furnished. Follow the procedure below to install.
- Refer to the circuit diagram on the control cover inside outdoor unit.

### In Case of 3 rooms

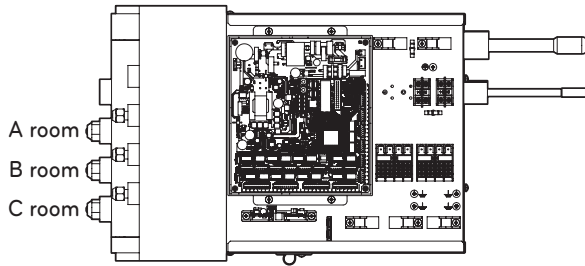

Connection wire for indoor units  
(AWG 18-3, 18-2)

Connection wire for outdoor units  
(AWG 18-3, 18-2)



## WARNING

Do not use tapped wires, stand wires, extension cords, or starburst connections, as they may cause overheating, electrical shock, or fire.

42 CONNECTING THE CABLE BETWEEN INDOOR UNIT, DISTRIBUTOR UNIT AND OUTDOOR UNIT

- 1 Remove the control cover. Loosen the two screws, and slide the cover in the direction of the arrow.
- 4 Put in the cover in the direction of the arrow then tighten the screws.

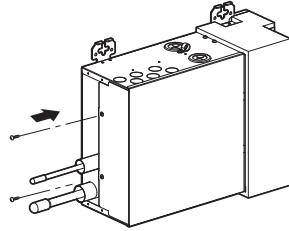
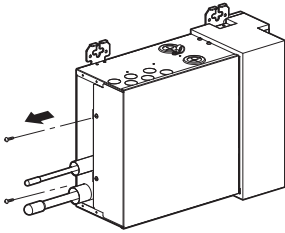

- 2 Pull out connection cable through conduit. After conduit to the panel, fix nut to the opposite side of panel. Pass the connection cable through the hole.

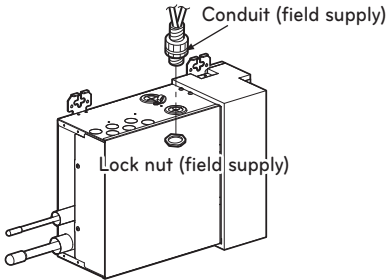

- 3 Perform wiring with reference the wiring diagram on a control cover of outdoor unit. Allow 300 mm (12 inch) for the pulling-out section of harness. Fix the wires completely with wire clamps (4 locations).

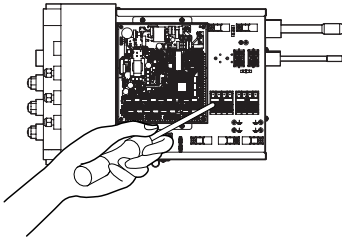

## Connect the cable to the Outdoor unit

- Remove the control cover from the unit by loosening the screw.  
Connect the wires to the terminals on the control board individually as the following.
- Secure the cable onto the control board with the holder (clammer).
- Re-attach the cover control to the original position using the screws.

Example) Connection of power and communication cable

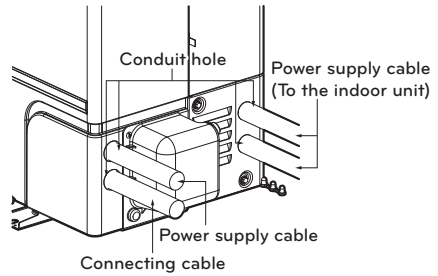

\* The figure can be changed according to model.

### 18, 24 kBTu/h class (Multi F)

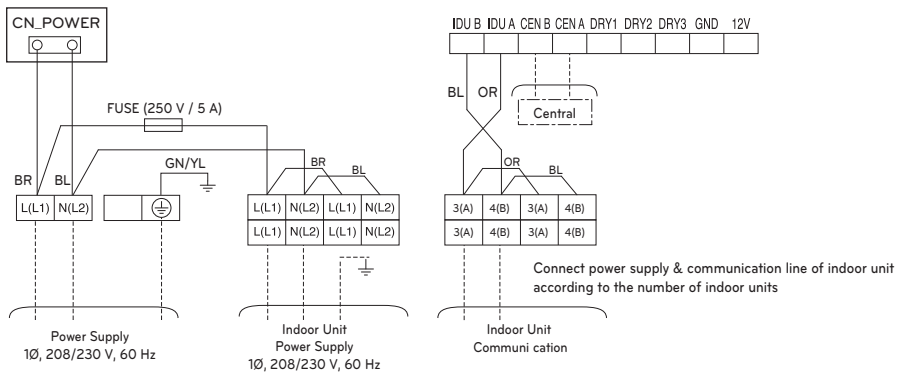

### 30, 36 kBTu/h class (Multi F)

### 18, 24, 30 kBTu/h class (Multi F LGRED®)

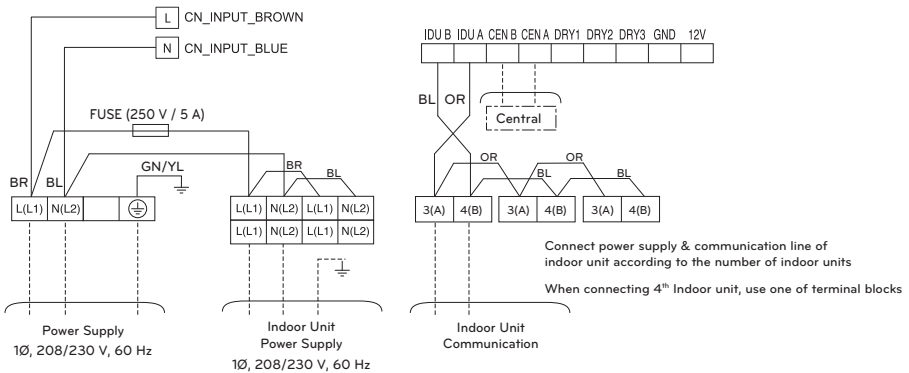

36, 42, 48 kBtu/h class (Multi F MAX with LGRED®)

48, 54, 60 kBtu/h class (Multi F MAX)

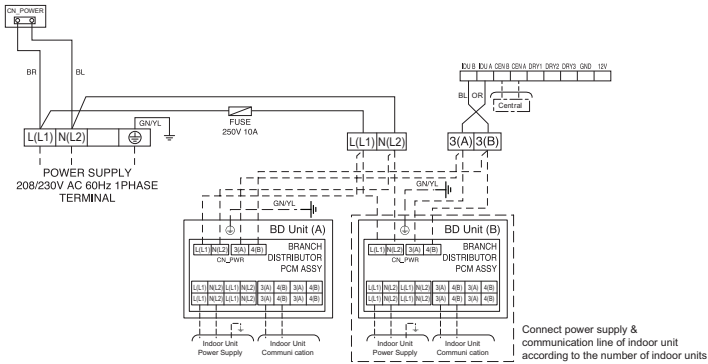
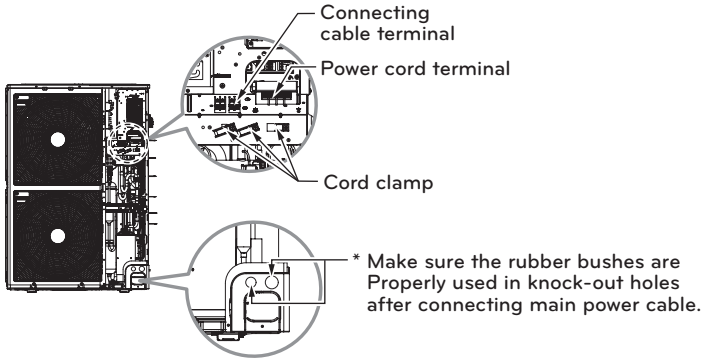

**NOTE**

Use connection cable NRTL(UL, ETL, CAS...) listed and stranded copper(4) THHN conductors, sunlight (UV) resistant ROHS compliant PVC jacket 600 V direct burial listed, approved for wet conditions.

Temperature rated for -20 °C (-4 °F) to 90 °C (194 °F). And this cable should be enclosed in conduit.

**WARNING**

- Be sure to comply with local and national codes while running the wire from the indoor unit to the outdoor unit(size of wire and wiring method, etc).
- Every wire must be connected firmly.
- No wire should be allowed to touch refrigerant tubing, the compressor or any moving parts.
- The communication wirings of air conditioner should be separate and isolated from external device's electric wiring such as computers, elevator, radio & Television broadcasting facilities, as well as medical imaging offices.

## Connection method of the connecting cable (Example)

- 1 Remove the side panel and knockouts of conduit panel. (for low voltage line)
- 2 Pull out connection cable through conduit.
- 3 After conduit to the panel, fix nut to the opposite side of panel.
- 4 Pass the connection cable through the hole.
- 5 Properly connect the cable on the terminal block.
- 6 Fix the connection cable with cord clamp provided on the unit not to have strain at the terminal when the connection cable is pulled outside up to a 35 pound weight.

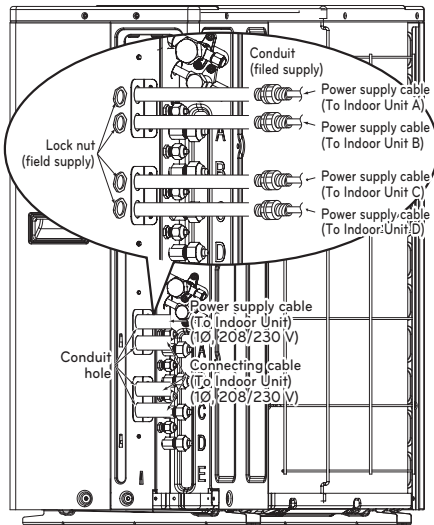

When connecting each power wire to the corresponding terminal, follow instructions "How to connect wiring to the terminals" and fasten the wire tightly with the fixing screw of the terminal plate.

### How to connect wiring to the terminals

⇒ For strand wiring

- 1 Cut the wire end with a wire cutter or wire-cutting pliers, then strip the insulation to expose the strand wiring about 10 mm (3/8").
- 2 Using a screwdriver, remove the terminal screw(s) on the terminal plate.
- 3 Using a round terminal fastener or pliers, securely clamp each stripped wire end with a round terminal.
- 4 Position the round terminal wire, and replace and tighten the terminal screw using a screwdriver.

### Power supply cable

#### Strand wire

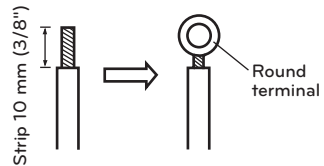

### Connecting Cable

Loosening the terminal block screw

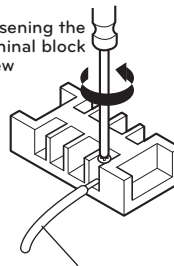

Connecting cable

Fastening the wire tightly

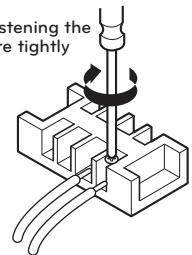

## WARNING

Loose wiring may cause the terminal to overheat or result in unit malfunction. A fire hazard may also exist. Therefore, be sure all wiring is tightly connected.

**Bad example**

- Do not insulate gas or low pressure pipe and liquid or highpressure pipe together.

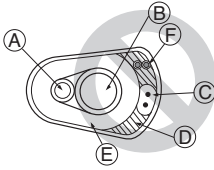

- Ⓐ Liquid pipe
- Ⓑ Gas pipe
- Ⓒ Power lines
- Ⓓ Finishing tape
- Ⓔ Insulating material
- Ⓕ Communication lines

- Be sure to fully insulate connecting portion.

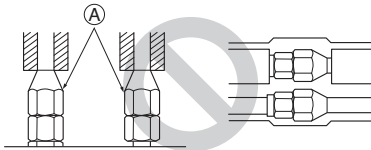

- Ⓐ These parts are not insulated.

**Good example**

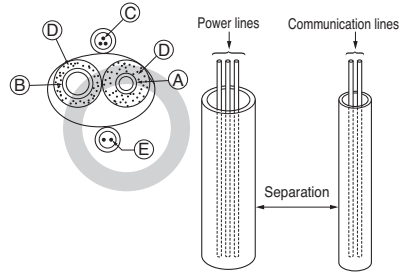

- Ⓐ Liquid pipe
- Ⓑ Gas pipe
- Ⓒ Power lines
- Ⓓ Insulating material
- Ⓔ Communication lines

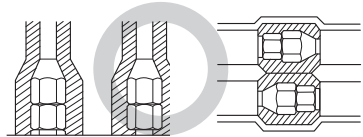

**! NOTE**

Separate minimum 2 inch (50mm) between power and communication cables for cable length greater than 131 ft (40 m).

# CHECKING THE DRAINAGE, INSULATING THE PIPE AND SPECIAL PIPING APPLICATIONS

## Checking the drainage

- 1 Remove the Air Filter.

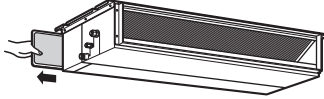

- 2 Check the drainage.
  - Spray one or two glasses of water upon the evaporator.
  - Ensure that water flows drain hose of indoor unit without any leakage.

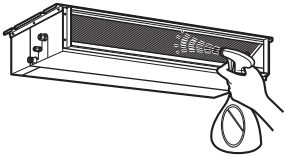

\* The figure can be changed according to model.

In cases where the outdoor unit is installed below the indoor unit perform the following.

- 1 Tape the piping, drain hose and connecting cable from down to up.
- 2 Secure the taped piping along the exterior wall using saddle or equivalent.

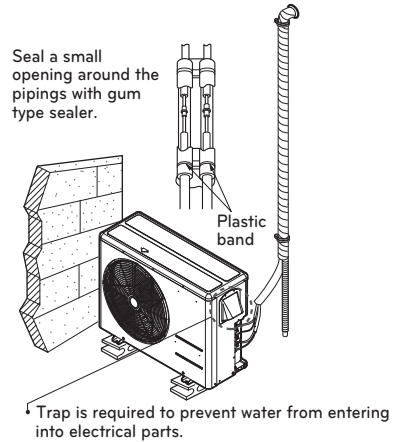

In cases where the Outdoor unit is installed above the Indoor unit perform the following.

- 1 Tape the piping and connecting cable from down to up.
- 2 Secure the taped piping along the exterior wall. Form a trap to prevent water entering the room.
- 3 Secure the piping onto the wall using a saddle or equivalent.

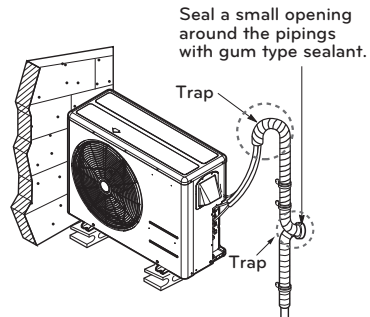

## Insulating the Pipe and Special Piping Applications

Insulate the piping by wrapping the connecting portion of the indoor unit with insulation material and secure it with two kinds of vinyl tape.

- If you want to connect an additional drain hose, the end of the drain outlet should be routed above the ground. Secure the drain hose appropriately. If you want to install the wires to be connected the Conduit Hall.

# AIR PURGING AND EVACUATION

Air and moisture remaining in the refrigerant system have undesirable effects as indicated below.

- Pressure in the system rises.
- Operating current rises.
- Cooling(or heating) efficiency drops.
- Moisture in the refrigerant circuit may freeze and block capillary tubing.
- Water may lead to corrosion of parts in the refrigeration system.

Therefore, the indoor/outdoor unit and connecting tube must be checked for leaks, and vacuumed to remove non-condensable gas and moisture in the system.

## Leak Checking

### Preparation

Check that each tube(both liquid and gas side tubes) between the indoor and outdoor units have been properly connected and all wiring for the test run has been completed. Remove the service valve caps from both the gas and the liquid sides on the outdoor unit. Check that both the liquid and the gas side service valves on the outdoor unit are kept closed at this stage.

### Leakage test

Connect the manifold valve(with pressure gauges) and dry nitrogen gas cylinder to this service port with charge hoses.

## CAUTION

Be sure to use a manifold valve for leak testing. The high side manifold valve must always be kept closed.

- Pressurize the system to no more than 550 P.S.I.G. with dry nitrogen gas and close the cylinder valve when the gauge reading reached 550 P.S.I.G. Next, test for leaks with liquid soap.

## CAUTION

To avoid nitrogen entering the refrigerant system in a liquid state, the top of the cylinder must be higher than its bottom when you pressurize the system. Usually, the cylinder is used in a vertical standing position.

## NOTE

Leakage testing should be done for each indoor unit connection set, separately.

- Do a leakage test of all joints of the tubing(both indoor and outdoor) and both gas and liquid side service valves with soap bubbles. Bubbles indicate a leak. Be sure to wipe off the soap with a clean cloth.
- After the system is found to be free of leaks, relieve the nitrogen pressure by loosening the charge hose connector at the nitrogen cylinder. When the system pressure is reduced to normal, disconnect the hose from the cylinder.

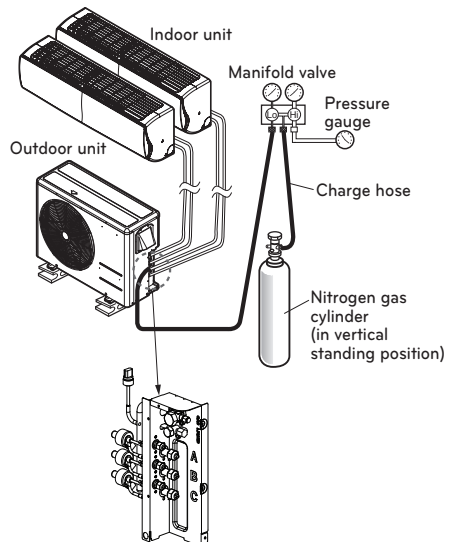

\* The figure can be changed according to model.

## Evacuation

- Connect the charge hose end described in the preceding steps to the vacuum pump to evacuate the tubing and indoor unit. Confirm the "Lo" knob of the manifold valve is open. Then, run the vacuum pump. The operation time for evacuation varies with tubing length and capacity of the pump. The following table shows the time required for evacuation.

Required time for evacuation when 30 gal/h vacuum pump is used	
If tubing length is less than 10m (33 ft)	If tubing length is longer than 10m (33 ft)
Less than 0.5 Torr	

- When the desired vacuum is reached, close the "Lo" knob of the manifold valve and stop the vacuum pump.

### Finishing the job

- With a service valve wrench, turn the valve stem of liquid side valve counter-clockwise to fully open the valve.
- Turn the valve stem of gas side valve counter-clockwise to fully open the valve.
- Loosen the charge hose connected to the gas side service port slightly to release the pressure, then remove the hose.
- Replace the flare nut and its bonnet on the gas side service port and fasten the flare nut securely with an adjustable wrench. This process is very important to prevent leakage from the system.
- Replace the valve caps at both gas and liquid side service valves and fasten them tight.

This completes air purging with a vacuum pump. The air conditioner is now ready for test running.

### ! NOTE

Repeat evacuation procedure for each indoor unit.

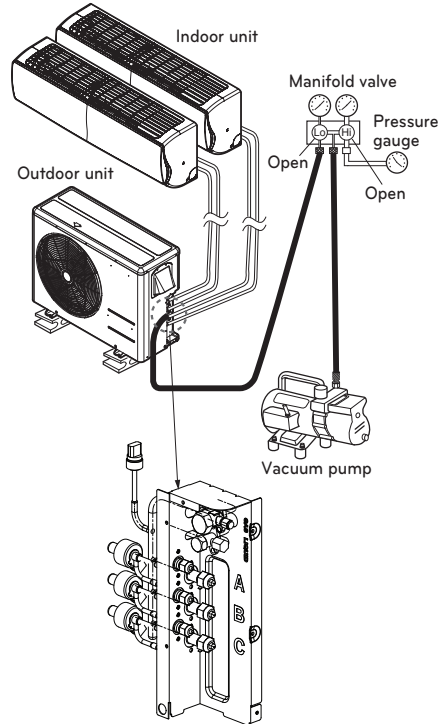

\* The figure can be changed according to model.

# CHARGING

If installed total piping length is more than standard total length, additional refrigerant charging is necessary. Below chargeless piping length, additional refrigerant charging is not required.

## Multiple Piping Models (Multi F)

Unit: m (ft)

Outdoor Unit Capacity (kBtu/h class)	Max total length of all pipes (A+B) / (A+B+C) / (A+B+C+D)	Max length of each pipe (A/B/C/D)	Min length of each pipe (A/B/C/D)	Additional Refrigerant Unit : g/m (oz/ft)	Standard Total Piping Length (No Add'l refrigerant)
18	50 (164)	25 (82)	3 (9.8)	20 (0.22)	30 (98.4)
24	70 (230)	25 (82)	3 (9.8)	20 (0.22)	30 (98.4)
30	75 (246)	25 (82)	3 (9.8)	20 (0.22)	37.5 (123)
36	75 (246)	25 (82)	3 (9.8)	20 (0.22)	37.5 (123)

## Multiple Piping Models (Multi F LGRED°)

Unit: m (ft)

Outdoor Unit Capacity (kBtu/h class)	Max total length of all pipes (A+B)/(A+B+C)/(A+B+C+D)	Max length of each pipe (A/B/C/D)	Min length of each pipe (A/B/C/D)	Additional Refrigerant Unit : g/m (oz/ft)	Standard Total Piping Length (No Add'l refrigerant)
18	50 (164.0)	25 (82.0)	3 (9.8)	20 (0.22)	25 (82)
24	75 (246.1)	25 (82.0)	3 (9.8)	20 (0.22)	37.5 (123)
30	75 (246.1)	25 (82.0)	3 (9.8)	20 (0.22)	37.5 (123)

## Distributor type Models (Multi F MAX)

Unit: m (ft)

Outdoor Unit Capacity (kBtu/h class)	Main Piping Length			Branch Piping Length	
	Standard Length	Chargeless	Additional Refrigerant Unit : g/m (oz/ft)	Standard Length	Additional Refrigerant Unit : g/m (oz/ft)
48	5 (16.4)	5 (16.4)	50 (0.54)	5 (16.4)	20 (0.22)
54	5 (16.4)	5 (16.4)	50 (0.54)	5 (16.4)	20 (0.22)
60	5 (16.4)	15 (49.2)	50 (0.54)	5 (16.4)	20 (0.22)

## Distributor type Models (Multi F MAX with LGRED°)

Unit: m (ft)

Outdoor Unit Capacity (kBtu/h class)	Main Piping Length			Branch Piping Length	
	Standard Length	Chargeless	Additional Refrigerant Unit : g/m (oz/ft)	Standard Length	Additional Refrigerant Unit : g/m (oz/ft)
36	5 (16.4)	15 (49.2)	50 (0.54)	5 (16.4)	20 (0.22)
42	5 (16.4)	15 (49.2)	50 (0.54)	5 (16.4)	20 (0.22)
48	5 (16.4)	15 (49.2)	50 (0.54)	5 (16.4)	20 (0.22)

**Important:**

If you are ever uncertain of the unit charge, reclaim, evacuate and weigh in the correct charge using the charge amount specified on the Unit's specification label.

**Multiple Piping Models**

Additional charge(oz) = (Total Installation Piping Length-chargeless Piping Length) x 0.22

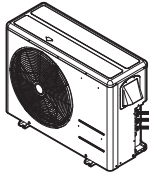

EX) KUMXB241A

Each branch pipe

a = 82 ft

b = 16 ft

c = 49 ft

\* Additional Charge

$$= \{(82+16+49)-98.4\} \times 0.22 = 10.69 \text{ oz}$$

**Distributor type Models**

Additional charge (oz) = (Total Main Piping Length – Standard Length of Main Pipe) x 0.54  
 + (Total Branch Piping Length – Standard Length of Branch Pipe) x 0.22  
 - CF(Correction Factor) x 3.53

\* CF = Max. number of connectable indoor unit – Total number of connected indoor unit



Ex) KUMXB601A

• Total main pipe(A+B+C)=98ft

• Each branch pipe

a = 33 ft

b = 26 ft

c = 16.4 ft

d = 10 ft

e = 33 ft

**Additional Charge**

$$= (98-16.4) \times 0.54 \\ + \{(33+26+16.4+10+33)-131.2\} \times 0.22 \\ - (8-5) \times 3.53 = 30.66 \text{ oz}$$

\* If the total additional charge value after calculation comes out to be negative, then do not consider additional charge.

**NOTE**

- The amount of refrigerant charged is based on the standardized pipe length. If the installed pipe is longer than the standard length, extra refrigerant needs to be added.
- If the total additional charge value after calculation comes out to be negative, then do not consider additional charge.
- Reliability cannot be guaranteed if the pipe is longer than the maximum length.

**Checking the safe handling**

Note down all of the following information on the label, especially the resulting total REFRIGERANT CHARGE for each REFRIGERATING SYSTEM

- ① Refrigerant charge of the precharged part of the appliance
- ② Refrigerant charge added during installation
- Total REFRIGERANT CHARGE
- Refrigerant type
- Date of first charge

① =  oz. /  kg

② =  oz. /  kg

---

①+② =  oz. /  kg

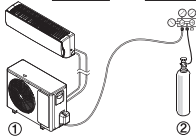

Refrigerant type

Date of first charge  
mm / dd / yyyy

/  /

Mark refrigerant pipes with red Pantone® Matching System (PMS) #185 or RAL 3020 after flare fittings or brazing. This marking must extend a minimum of 1 inch (25mm) in both directions and shall be replaced if removed.

**Multi F / Multi F with LGRED°**

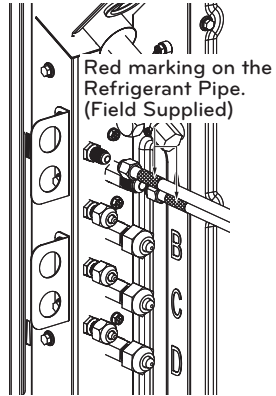

**Multi F MAX / Multi F MAX with LGRED°**

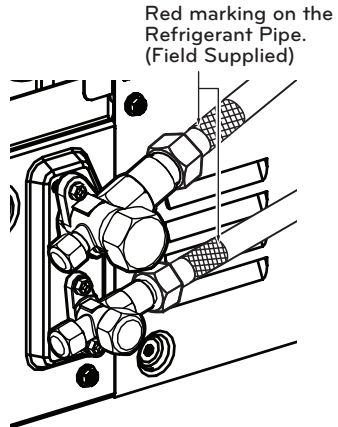

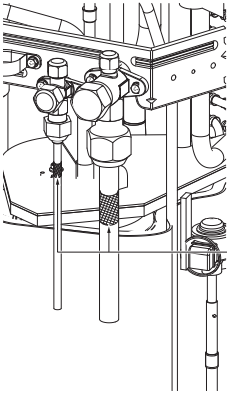
**Multi F MAX / Multi F MAX with LGRED°**

Red marking on the  
Refrigerant Pipe.  
(Field Supplied)

Return all labels, especially red marking, to their original condition to ensure the next consumer or servicer is aware of the presence of a flammable refrigerant.

Ensure that the red marking for flammable refrigerant identification in the process tube area is visible following servicing.

\* The feature may be changed according to the type of model.

# CHECKING THE SETTING OF OUTDOOR UNIT

Make sure to complete the manual or auto pipe detection process before test running. Otherwise, the product will not work.

## Main PCB

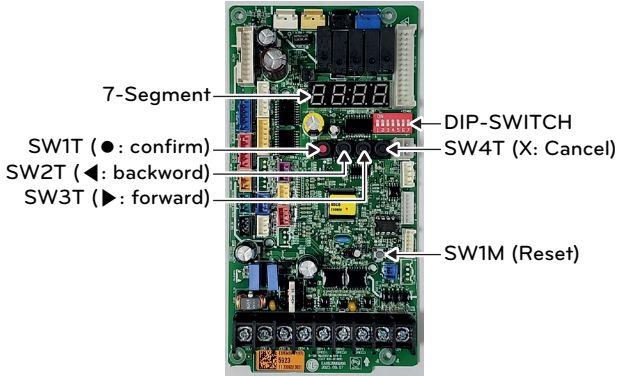

## Branch Distributor Unit Main PCB (Only Multi F MAX and Multi F MAX with LGRED<sup>®</sup>)

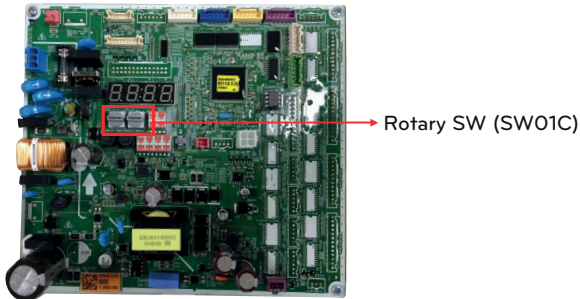

Setup the switch of BD Unit (Only Multi F MAX and Multi F MAX with LGRED<sup>®</sup>)

SW		Function	
Rotary SW		SW01C (Right)	- Manual addressing of zoning indoor units - Setting to address BD units

**SW01C (Rotary SW for addressing BD unit)**

Must be set to '0' when installing only one BD unit.

When installing multiple BD units, address the BD units with sequentially increasing numbers starting from '0'.

Maximum 2 BD units can be installed.

Ex) Installation of 2 BD units

\* Master Only

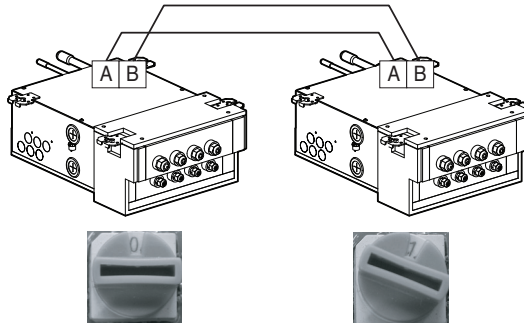
**CAUTION**

- In replacement of the indoor unit PCB, always perform pipe detection process again
- If power supply is not applied to the indoor unit, operation error occur.
- Pipe detection process has to be performed more than 3 minutes after power supply to improve indoor unit communication.
- Please be sure that all the DIP switch (1~7) of outdoor unit is OFF before pipe detection process.
- If there occurs some error during pipe detection process, it means pipe detection process is not properly finished.

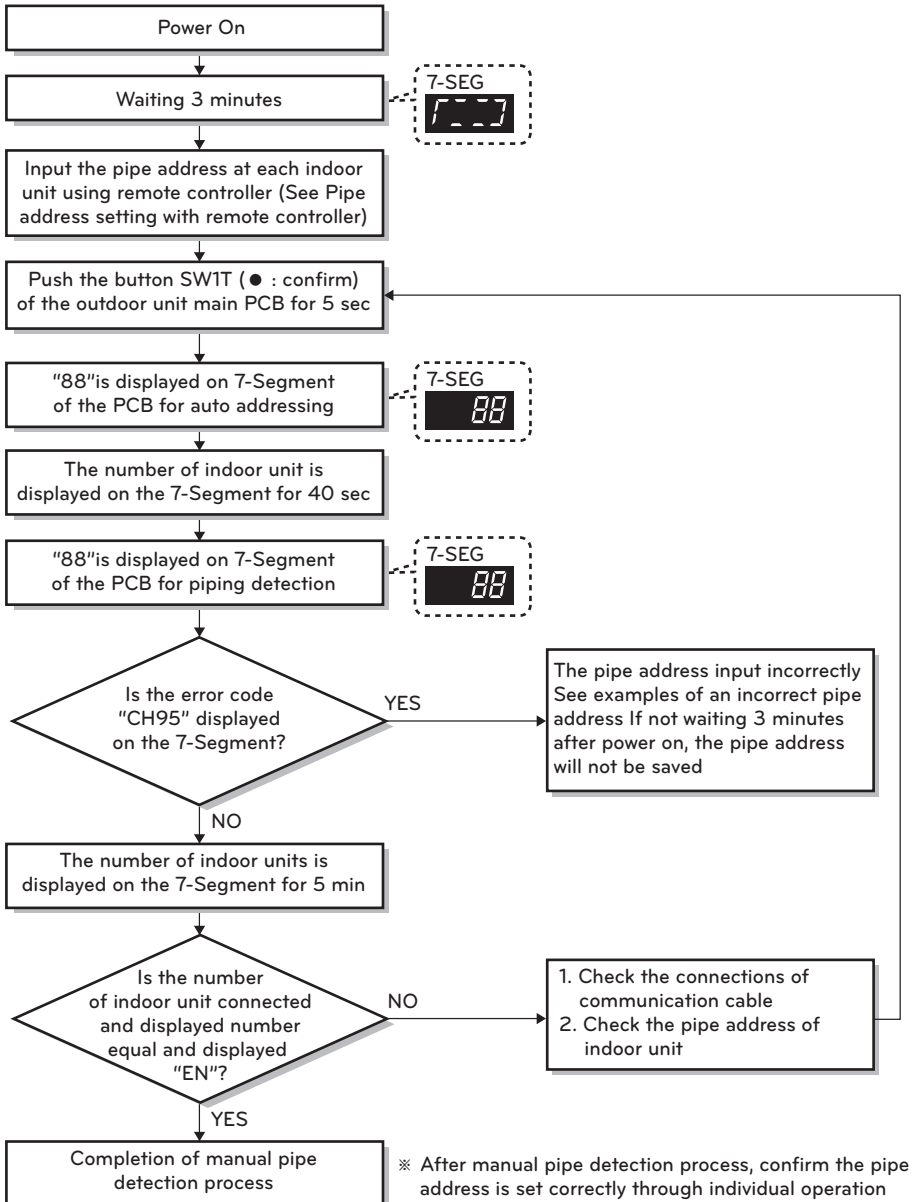
Manual Pipe Detection Process (Multi F and Multi F with LGRED<sup>o</sup>)

No	Incorrect cases	Examples		Display
1	Duplicate pipe address	Actual pipe address	Input pipe address	CH95
		A	A	
		B	A	
2	No pipe address	Actual pipe address	Input pipe address	CH95
		A	A	
		B	-	
3	Crossed pipe address	Actual pipe address	Input pipe address	No error
		A	B	
		B	A	
4	Unconnected pipe address	Actual pipe address	Input pipe address	No error
		A	A	
		B	C	

### Auto Pipe Detection Process (Multi F and Multi F with LGRED<sup>®</sup>)

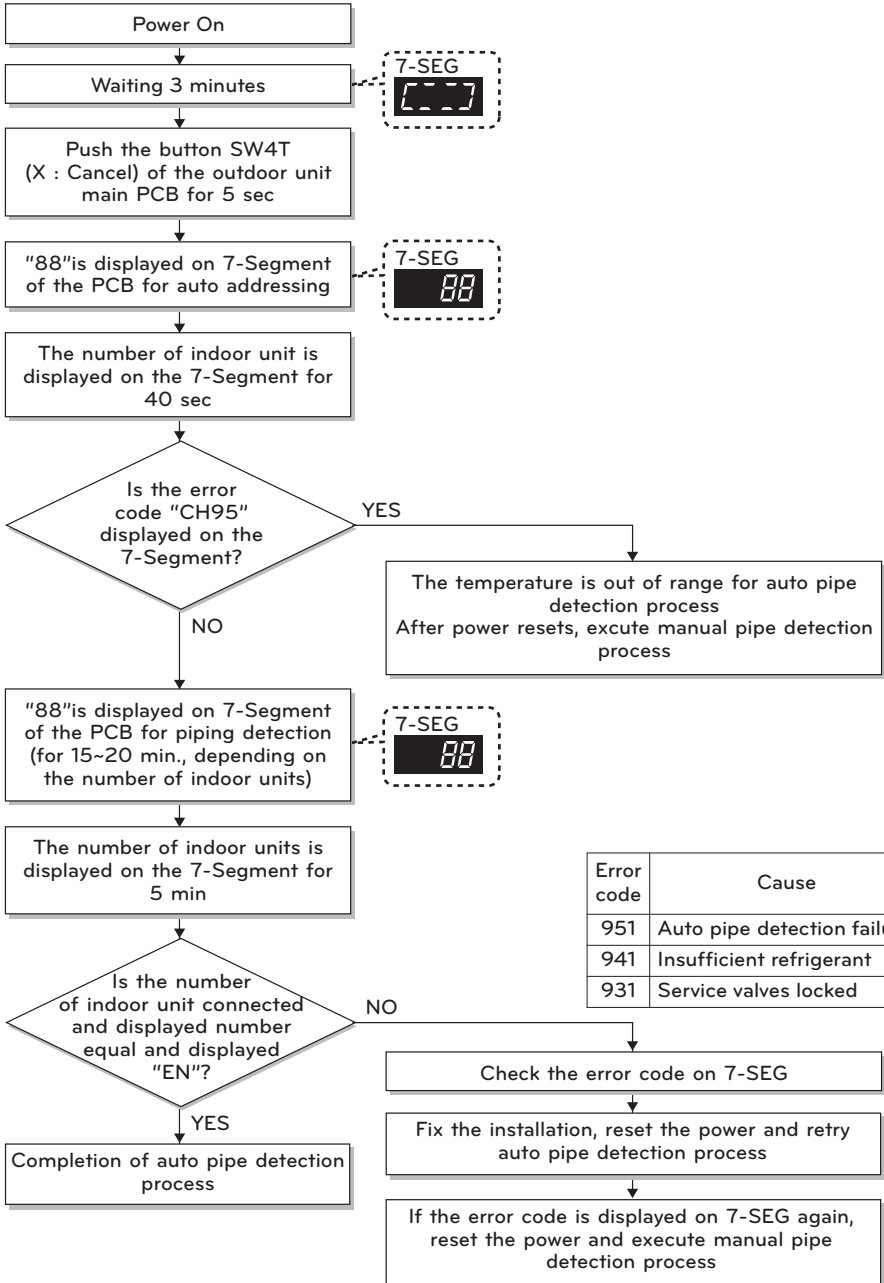

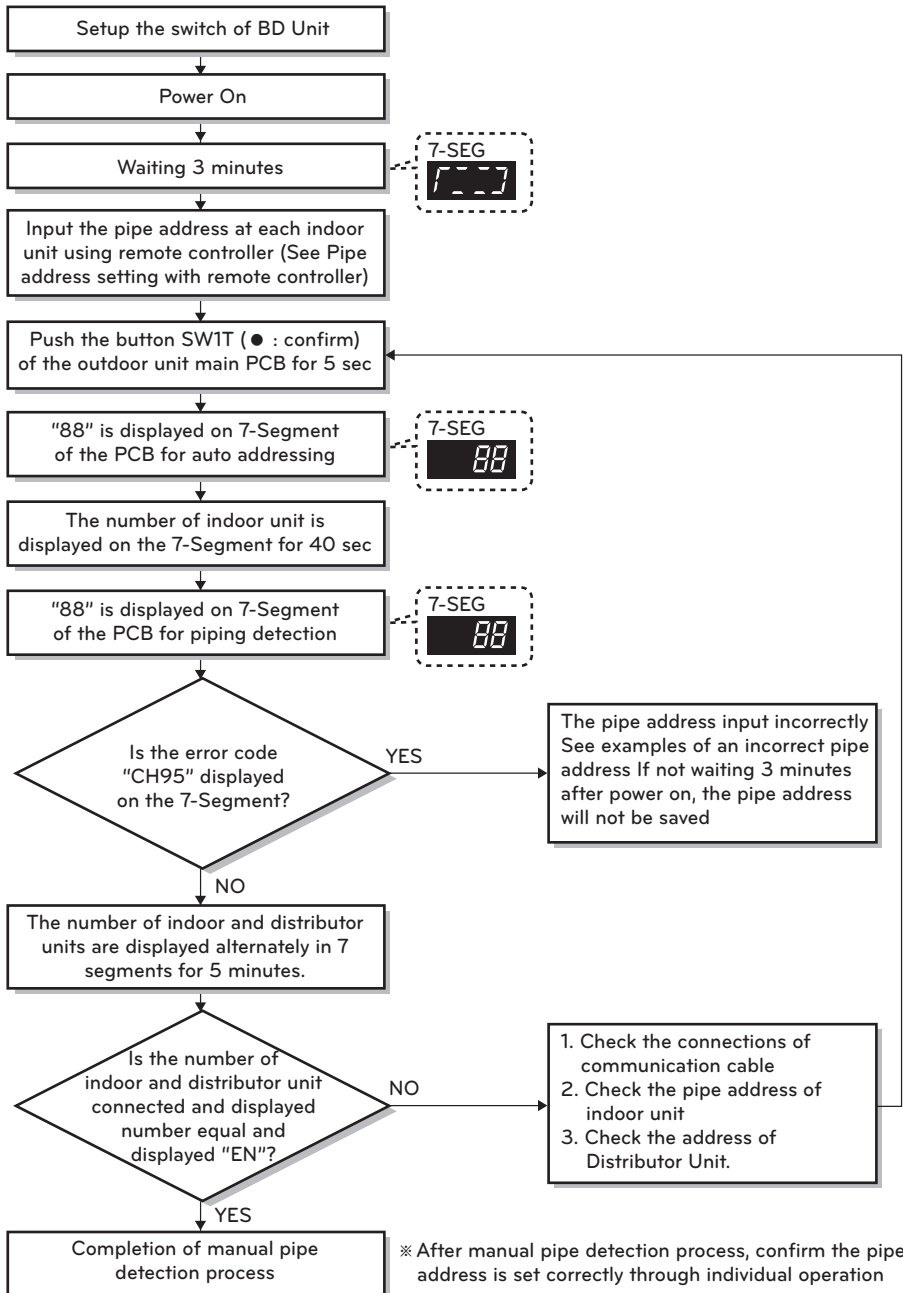
Manual Pipe Detection Process (Multi F MAX and Multi F MAX with LGRED<sup>®</sup>)

No	Incorrect cases	Examples		Display					
1	Duplicate pipe address	<table border="1"> <thead> <tr> <th data-bbox="418 188 667 231">Actual pipe address</th> <th data-bbox="667 188 916 231">Input pipe address</th> </tr> </thead> <tbody> <tr> <td data-bbox="418 231 667 258">A</td> <td data-bbox="667 231 916 258">A</td> </tr> <tr> <td data-bbox="418 258 667 293">B</td> <td data-bbox="667 258 916 293">A</td> </tr> </tbody> </table>	Actual pipe address	Input pipe address	A	A	B	A	CH95
Actual pipe address	Input pipe address								
A	A								
B	A								
2	No pipe address	<table border="1"> <thead> <tr> <th data-bbox="418 304 667 347">Actual pipe address</th> <th data-bbox="667 304 916 347">Input pipe address</th> </tr> </thead> <tbody> <tr> <td data-bbox="418 347 667 375">A</td> <td data-bbox="667 347 916 375">A</td> </tr> <tr> <td data-bbox="418 375 667 410">B</td> <td data-bbox="667 375 916 410">-</td> </tr> </tbody> </table>	Actual pipe address	Input pipe address	A	A	B	-	CH95
Actual pipe address	Input pipe address								
A	A								
B	-								
3	Crossed pipe address	<table border="1"> <thead> <tr> <th data-bbox="418 427 667 470">Actual pipe address</th> <th data-bbox="667 427 916 470">Input pipe address</th> </tr> </thead> <tbody> <tr> <td data-bbox="418 470 667 497">A</td> <td data-bbox="667 470 916 497">B</td> </tr> <tr> <td data-bbox="418 497 667 533">B</td> <td data-bbox="667 497 916 533">A</td> </tr> </tbody> </table>	Actual pipe address	Input pipe address	A	B	B	A	No error
Actual pipe address	Input pipe address								
A	B								
B	A								
4	Unconnected pipe address	<table border="1"> <thead> <tr> <th data-bbox="418 550 667 593">Actual pipe address</th> <th data-bbox="667 550 916 593">Input pipe address</th> </tr> </thead> <tbody> <tr> <td data-bbox="418 593 667 620">A</td> <td data-bbox="667 593 916 620">A</td> </tr> <tr> <td data-bbox="418 620 667 655">B</td> <td data-bbox="667 620 916 655">C</td> </tr> </tbody> </table>	Actual pipe address	Input pipe address	A	A	B	C	No error
Actual pipe address	Input pipe address								
A	A								
B	C								

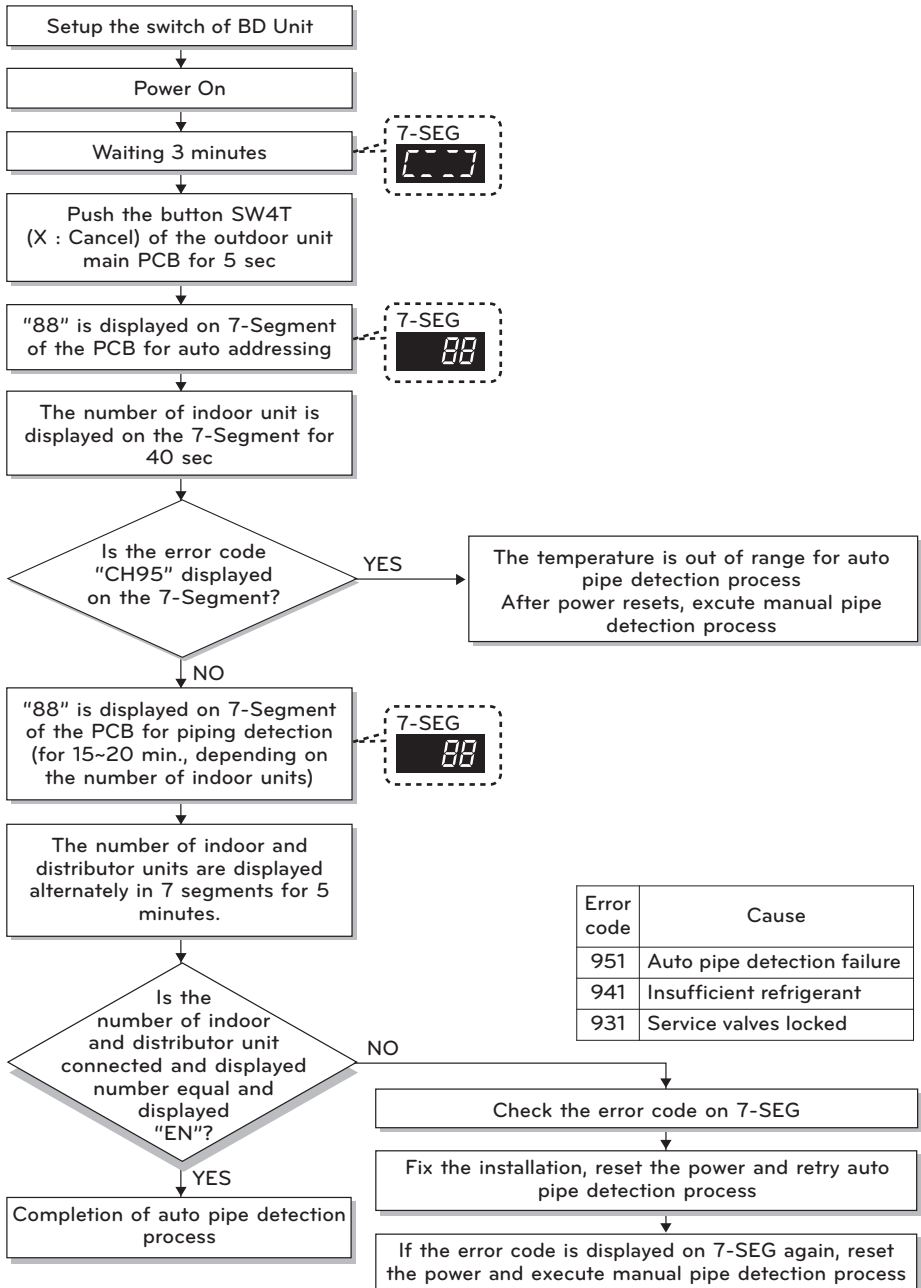
Auto Pipe Detection Process (Multi F MAX and Multi F MAX with LGRED<sup>®</sup>)

# PIPING ADDRESS SETTING WITH REMOTE CONTROLLER

## Wireless remote controller

### Piping address setting

- 1 With the  or  or  button pressed, press the reset button.



- 2 By using the  button, set the piping address.  
Piping address means the pipe location of the outdoor unit.  
(A, B, C... from the top of the outdoor unit)

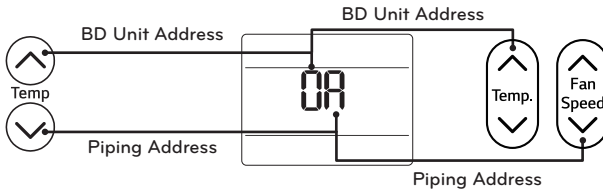

- Ex) 1A, 1B... → indoor units connected to 0 set BD unit  
 2A, 2B... → indoor units connected to 1 set BD unit  
 0A, 0B... → indoor units connected to Multi F and Multi F with LGRED°

- 3 After setting the address, press the  button toward the indoor unit 1 time.
- 4 The indoor unit will display the piping address after complete the setting.  
- The address display time and method can be differ by the indoor unit type.
- 5 Reset the remote controller to use the general operation mode.

## Standard 3 Wired remote controller

### Piping address setting

- 1 In the menu screen, press [**<**, **>** (left/right)] button to select the setting category, and press [**^** (up)] button for 3 seconds to enter the password input screen for the installer setting.
- 2 Input the password and press [OK] button to move to the installer setting list.

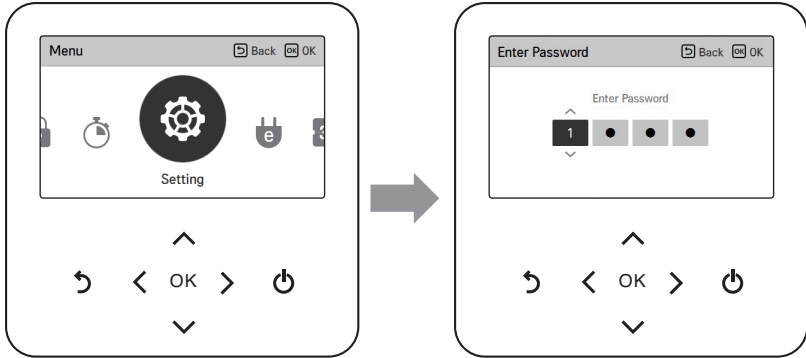

\* Installer setting password

Main screen → menu → setting → service → RMC version information → SW Version  
 Example) SW version : 1.00.1 a

In the above case, the password is 1001.

- 3 In the installer setting list, select the Piping Address Setting category, and press [OK] button to move the detail screen.
  - Select a value between 0A and 0D for each indoor unit according to the location of the pipes connected to the outdoor unit. (A, B, C, ... from the top of the outdoor unit)

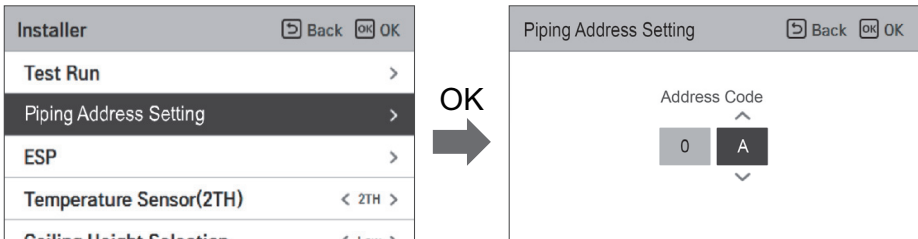

# TEST RUNNING

- Check that all tubing and wiring have been properly connected.
- Check that the gas and liquid side service valves are fully open.

## Prepare remote control

Remove the battery cover by pulling it according to the arrow direction.  
 Insert new batteries making sure that the (+) and (-) of battery are installed correctly.  
 Reattach the cover by pushing it back into position.

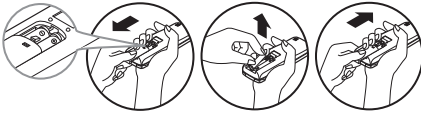

### ! NOTE

- Use 2 AAA (1.5 volt) batteries. Do not use rechargeable batteries.
- Remove the batteries from the remote control if the system is not going to be used for a long time.

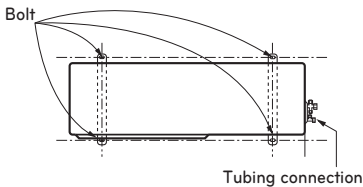

## Evaluation of the performance

Operate unit for 15~20 minutes, then check the system refrigerant charge:

- Measure the pressure of the gas side service valve.
- Measure the temperature of the intake and discharge of air.
- Ensure the difference between the intake temperature and the discharge is more than 8 °C.

- For reference, the gas side pressure of optimum condition is as below. (Cooling)

Refrigerant	Outside ambient TEMP.	The pressure of the gas side service valve.
R32	35 °C (95 °F)	8.5~9.5 kg/cm <sup>2</sup> G (120~135 P.S.I.G.)

### ! NOTE

If the actual pressure are higher than shown, the system is most likely over-charged, and charge should be removed. If the actual pressure are lower than shown, the system is most likely undercharged, and charge should be added.

The air conditioner is now ready for use.

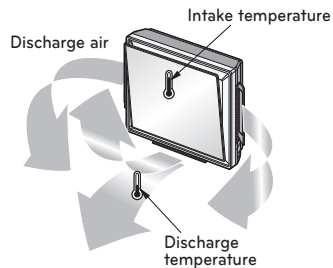
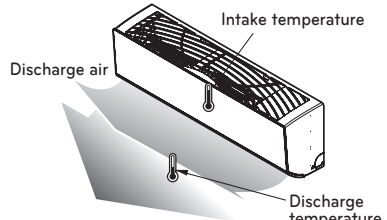
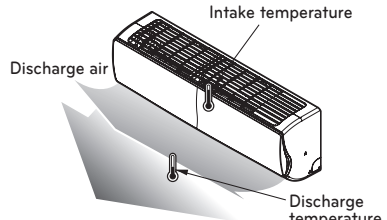

# FUNCTION

## DIP S/W Setting

If you set the DIP Switch when power is on, the change in setting is not applicable. The changing setting is enabled only when Power is reset.



DIP Switch							Function
1	2	3	4	5	6	7	
							Normal Operation (No Function)
							Forced Cooling Operation
							Saving Power Consumption (Step 1)
							Saving Power Consumption (Step 2)
							Mode Lock (Cooling)
							Mode Lock (Heating)
							Night Quiet Mode (Step 1)
							Night Quiet Mode (Step 2)
							Mode Lock (Cooling) + Night Quiet Mode (Step 1)
							Mode Lock (Cooling) + Night Quiet Mode (Step 2)
							Mode Lock (Cooling) + Saving Power Consumption (Step 1)
							Mode Lock (Cooling) + Saving Power Consumption (Step 2)
							Mode Lock (Heating) + Saving Power Consumption (Step 1)
							Mode Lock (Heating) + Saving Power Consumption (Step 2)

### ⚠ WARNING

When you set the DIP switch, you should turn off the circuit breaker or shut the power source of the product down.

### ⚠ CAUTION

- Unless the applicable DIP switch is set properly, the product may not work.
- If you want to set a specific function, request that the installer sets the DIP switch appropriately during installation.

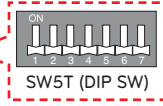
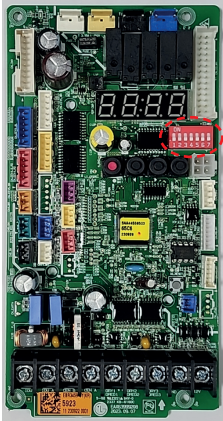

## Saving Power Consumption

Saving Power Consumption operation is the function which enables efficient operation by lowering the maximum power consumption value.

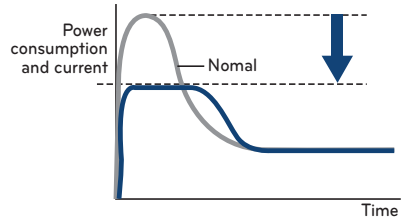

## Forced Cooling Operation

Adding the refrigerant in winter.

### Setting Procedure

- 1 Set the DIP Switch as follow after shutting the power source down.



- 2 Reset the power.
- 3 Check that the Red LED of PCB is on during work. (The indoor unit is operated by force.)
- 4 Add the specific amount of refrigerant.

### CAUTION

- When the green LED of PCB is on, compressor is going to be off because of low pressure.
- You should return the DIP Switch to operate normally after finishing the operation.

### Setting Procedure

- 1 Set the DIP Switch as follow after shutting the power source down.

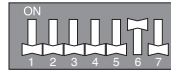

Step 1

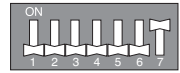

Step 2

- 2 Reset the power.

### Saving Power Consumption Current level

Phase	1Ø		
Model (kBTu/h Class)	18/24	30/36	48/54/60
Step 1 (A)	9	13	22
Step 2 (A)	8	11	21

### Saving Power Consumption with Mode Lock



Saving Power Consumption (step 1) + Mode Lock (Cooling)



Saving Power Consumption (step 2) + Mode Lock (Cooling)



Saving Power Consumption (step 1) + Mode Lock (Heating)



Saving Power Consumption (step 2) + Mode Lock (Heating)

## Night Quiet Mode

Night Quiet Mode operation lowers the noise level of the outdoor unit by changing the comp frequency and fan speed. This function is operated all night long.

### Setting Procedure

- 1 Set the DIP Switch as follow after shutting the power source down.



Step 1



Step 2

※ Noise level : Step 1 > Step 2

- 2 Reset the power.

### Night Quiet Mode with Mode Lock



Mode Lock (Cooling) +  
Night Quiet Mode (step 1)



Mode Lock (Cooling) +  
Night Quiet Mode (step 2)

## Mode Lock

### Setting Procedure

- 1 Set the DIP Switch as follow after shutting the power source down.

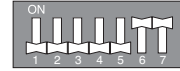

Only Cooling Mode    Only Heating Mode

- 2 Reset the power.

### Saving Power Consumption with Mode Lock



Mode Lock (Cooling)  
+ Saving Power  
Consumption (step 1)



Mode Lock (Cooling)  
+ Saving Power  
Consumption (step 2)



Mode Lock (Heating)  
+ Saving Power  
Consumption (step 1)



Mode Lock (Heating)  
+ Saving Power  
Consumption (step 2)



## CAUTION

- If comp frequency and fan speed are down, the cooling capacity may decrease accordingly.
- This function is only available for Cooling Mode.
- If you want to stop the Night Quiet Mode, Change the DIP Switch.
- If operating indoor unit is set by the fan speed "Power", Night Quiet Mode will be stopped until fan speed "Power" is changed.

# MAX COMBINATION CAPACITY

## Multi Piping Type (Multi F)

Capacity (kBtu/h class)	Max Room No.	Combination Indoor Capacity (kBtu/h class)	Max Combination Capacity (kBtu/h class)
18	2	7,9,12,15	24
24	3	7,9,12,15,18	33
30	4	7,9,12,15,18,24	40
36	4	7,9,12,15,18,24	48

## Multi Piping Type (Multi F LGRED°)

Capacity (kBtu/h class)	Max Room No.	Combination Indoor Capacity (kBtu/h class)	Max Combination Capacity (kBtu/h class)
18	2	7, 9, 12, 15	24
24	3	7, 9, 12, 15, 18	33
30	4	7, 9, 12, 15, 18, 24	40

## Distributor type Models (Multi F MAX)

Phase	Capacity (kBtu/h class)	Max Room No.	Combination Indoor Capacity (kBtu/h class)	Max Combination Capacity (kBtu/h class)
1Ø	48	8	7, 9, 12, 15, 18, 24, 30, 36	65
1Ø	54	8	7, 9, 12, 15, 18, 24, 30, 36	73
1Ø	60	8	7, 9, 12, 15, 18, 24, 30, 36	81

## Distributor type Models (Multi F MAX with LGRED°)

Phase	Capacity (kBtu/h class)	Max Room No.	Combination Indoor Capacity (kBtu/h class)	Max Combination Capacity (kBtu/h class)
1Ø	36	5	7, 9, 12, 15, 18, 24	48
1Ø	42	6	7, 9, 12, 15, 18, 24, 30, 36	56
1Ø	48	8	7, 9, 12, 15, 18, 24, 30, 36	65

The combination of indoor unit is to be decided that the sum of indoor unit capacity index must be smaller than the maximum combination capacity of outdoor unit. We recommend to calculate indoor unit capacity like below.

If you do not follow factory recommendation, low system pressure may result in low ambient condition i.e. some indoor unit will not be able to heat very well in heating mode.

# INSTALLATION GUIDE AT THE SEASIDE

## CAUTION

- Air conditioners should not be installed in areas where corrosive gases, such as acid or alkaline gas, are produced.
- Do not install the product where it could be exposed to sea wind (salty wind) directly. It can result corrosion on the product. Corrosion, particularly on the condenser and evaporator fins, could cause product malfunction or inefficient performance.
- If outdoor unit is installed close to the seaside, it should avoid direct exposure to the sea wind. Otherwise it needs additional anticorrosion treatment on the heat exchanger.

In case, to install the outdoor unit on the seaside, set up a windbreak not to be exposed to the sea wind.

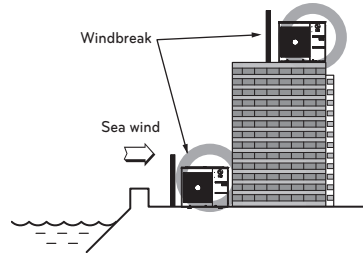

- It should be strong enough like concrete to prevent the sea wind from the sea.
- The height and width should be more than 150% of the outdoor unit.
- It should be keep more than 70 cm (27 1/16 inches) of space between outdoor unit and the windbreak for easy air flow.

## Selecting the location(Outdoor Unit)

If the outdoor unit is to be installed close to the seaside, direct exposure to the sea wind should be avoided. Install the outdoor unit on the opposite side of the sea wind direction.

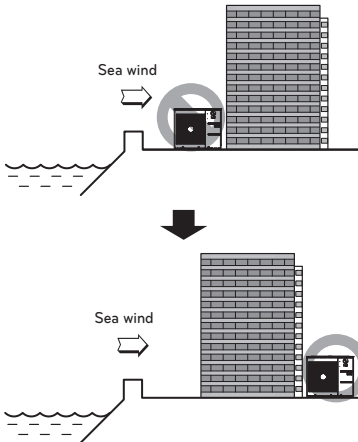

## Place with fluent water draining

- Install at a place with fluent water draining to prevent damage from localized heavy rain and avoid frequent flooded area.

- Periodic ( more than once/year ) cleaning of the dust or salt particles stuck on the heat exchanger by using water.

## SEASONAL WIND AND CAUTIONS IN WINTER

- Sufficient measures are required in a snow area or severe cold area in winter so that product can be operated well.
- Get ready for seasonal wind or snow in winter even in other areas.
- Install a suction and discharge duct not to let in snow or rain.
- Install the outdoor unit not to come in contact with snow directly. If snow piles up and freezes on the air suction hole, the system may malfunction. If it is installed at snowy area, attach the hood to the system.
- Install the outdoor unit at the higher installation console by 50 cm (20 in) than the average snowfall (annual average snowfall) if it is installed at the area with much snowfall.
- Where snow accumulated on the upper part of the Outdoor Unit by more than 10 cm (4 in), always remove snow for operation.

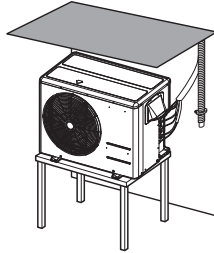

- 1 The height of H frame must be more than 2 times the snowfall and its width shall not exceed the width of the product. (If width of the frame is wider than that of the product, snow may accumulate)
- 2 Don't install the suction hole and discharge hole of the Outdoor Unit facing the seasonal wind.



US	Please call the installing contractor of your product, as warranty service will be provided by them.
CANADA	Service call Number # : (888) LG Canada, (888) 542-2623 Numéro pour les appels de service : LG Canada, 1-888-542-2623