

INSTALLATION MANUAL

AIR CONDITIONER

Please read this installation manual completely before installing the product. Installation work must be performed in accordance with the national wiring standards by authorized personnel only. Please retain this installation manual for future reference after reading it thoroughly.

CEILING CONCEALED DUCT



MFL67939907
Rev.02_062321

TIPS FOR SAVING ENERGY

Here are some tips that will help you minimize the power consumption when you use the air conditioner. You can use your air conditioner more efficiently by referring to the instructions below:

- Do not cool excessively indoors. This may be harmful for your health and may consume more electricity.
- Block sunlight with blinds or curtains while you are operating the air conditioner.
- Keep doors or windows closed tightly while you are operating the air conditioner.
- Adjust the direction of the air flow vertically or horizontally to circulate indoor air.
- Speed up the fan to cool or warm indoor air quickly, in a short period of time.
- Open windows regularly for ventilation as the indoor air quality may deteriorate if the air conditioner is used for many hours.
- Clean the air filter once every 2 weeks. Dust and impurities collected in the air filter may block the air flow or weaken the cooling / dehumidifying functions.

For your records

Staple your receipt to this page in case you need it to prove the date of purchase or for warranty purposes. Write the model number and the serial number here:

Model number : _____

Serial number : _____

You can find them on a label on the side of each unit.

Dealer's name : _____

Date of purchase : _____

IMPORTANT SAFETY INSTRUCTIONS

READ ALL INSTRUCTIONS BEFORE USING THE APPLIANCE.

Always comply with the following precautions to avoid dangerous situations and ensure peak performance of your product

WARNING

It can result in serious injury or death when the directions are ignored

CAUTION

It can result in minor injury or product damage when the directions are ignored

WARNING

- Installation or repairs made by unqualified persons can result in hazards to you and others.
- Installation **MUST** conform with local building codes or, in the absence of local codes, with the Nation Electrical Code NFPA 70/ANSI C1-1003 or current edition and Canadian Electrical Code Part1 CSA C.22.1.
- The information contained in the manual is intended for use by a qualified service technician familiar with safety procedures and equipped with the proper tools and test instruments.
- Failure to carefully read and follow all instructions in this manual can result in equipment malfunction, property damage, personal injury and/or death.

Installation

- Always perform grounding.
 - Otherwise, it may cause electrical shock.
- Don't use a power cord, a plug or a loose socket which is damaged.
 - Otherwise, it may cause a fire or electrical shock.
- For installation of the product, always contact the service center or a professional installation agency.
 - Otherwise, it may cause a fire, electrical shock, explosion or injury.
- Securely attach the electrical part cover to the indoor unit and the service panel to the outdoor unit.
 - If the electrical part cover of the indoor unit and the service panel of the outdoor unit are not attached securely, it could result in a fire or electric shock due to dust, water, etc.
- Always install an air leakage breaker and a dedicated switching board.
 - No installation may cause a fire and electrical shock.
- Do not keep or use flammable gases or combustibles near the air conditioner.
 - Otherwise, it may cause a fire or the failure of product.
- Ensure that an installation frame of the outdoor unit is not damaged due to use for a long time.
 - It may cause injury or an accident.
- Do not disassemble or repair the product randomly.
 - It will cause a fire or electrical shock.
- Do not install the product at a place that there is concern of falling down.
 - Otherwise, it may result in personal injury.
- Use caution when unpacking and installing.
 - Sharp edges may cause injury.
- Do not turn on the breaker or power under condition that front panel, cabinet, top cover, control box cover are removed or opened.
 - Otherwise, it may cause fire, electric shock, explosion or death.

Operation

- Do not share the outlet with other appliances.
 - It will cause an electric shock or a fire due to heat generation.
- Do not use the damaged power cord.
 - Otherwise, it may cause a fire or electrical shock.
- Do not modify or extend the power cord randomly.
 - Otherwise, it may cause a fire or electrical shock.

4 IMPORTANT SAFETY INSTRUCTIONS

- Take care so that the power cord may not be pulled during operation.
 - Otherwise, it may cause a fire or electrical shock.
- Unplug the unit if strange sounds, smell, or smoke comes from it.
 - Otherwise, it may cause electrical shock or a fire.
- Keep the flames away.
 - Otherwise, it may cause a fire.
- Take the power plug out if necessary, holding the head of the plug and do not touch it with wet hands.
 - Otherwise, it may cause a fire or electrical shock.
- Do not use the power cord near the heating tools.
 - Otherwise, it may cause a fire and electrical shock.
- Do not open the suction inlet of the indoor/outdoor unit during operation.
 - Otherwise, it may electrical shock and failure.
- Do not allow water to run into electrical parts.
 - Otherwise, it may cause the failure of machine or electrical shock.
- Hold the plug by the head when taking it out.
 - It may cause electric shock and damage.
- Never touch the metal parts of the unit when removing the filter.
 - They are sharp and may cause injury.
- Do not step on the indoor/outdoor unit and do not put anything on it.
 - It may cause an injury through dropping of the unit or falling down.
- Do not place a heavy object on the power cord.
 - Otherwise, it may cause a fire or electrical shock.
- When the product is submerged into water, always contact the service center.
 - Otherwise, it may cause a fire or electrical shock.
- Take care so that children may not step on the outdoor unit.
 - Otherwise, children may be seriously injured due to falling down.

CAUTION

Installation

- Install the drain hose to ensure that drain can be securely done.
 - Otherwise, it may cause water leakage.
- Install the product so that the noise or hot wind from the outdoor unit may not cause any damage to the neighbors.
 - Otherwise, it may cause dispute with the neighbors.
- Always inspect gas leakage after the installation and repair of product.
 - Otherwise, it may cause the failure of product.
- Keep level parallel in installing the product.
 - Otherwise, it may cause vibration or water leakage.
- Do not install the unit in potentially explosive atmospheres.

Operation

- Avoid excessive cooling and perform ventilation sometimes.
 - Otherwise, it may do harm to your health.
- Use a soft cloth to clean. Do not use wax, thinner, or a strong detergent.
 - The appearance of the air conditioner may deteriorate, change color, or develop surface flaws.
- Do not use an appliance for special purposes such as preserving animals vegetables, precision machine, or art articles.
 - Otherwise, it may damage your properties.
- Do not place obstacles around the flow inlet or outlet.
 - Otherwise, it may cause the failure of appliance or an accident.

TABLE OF CONTENTS

2 TIPS FOR SAVING ENERGY

3 IMPORTANT SAFETY INSTRUCTIONS

6 INTRODUCTION

6 Features

7 INSTALLATION OF INDOOR

7 Selection of the best location

7 Ceiling dimension and hanging bolt location

9 Wiring Connection

11 Indoor Unit Drain Piping

11 Drain test

12 Heat insulation

13 REMOTE CONTROLLER INSTALLATION

14 Group Control

16 OPTIONAL OPERATION

16 Installer Setting - Test Run Mode

17 Installer Setting - Setting Address of Central Control

18 Installer Setting - Thermistor

19 Installer Setting - Remote Controller Master/Slave Setup

20 Installer Setting - Celsius / Fahrenheit Switching

21 Installer Setting - E.S.P.

22 Installer Setting - Static Pressure Step Setting





27 Installer Setting - Auto ESP

30 DIP SWITCH SETTING

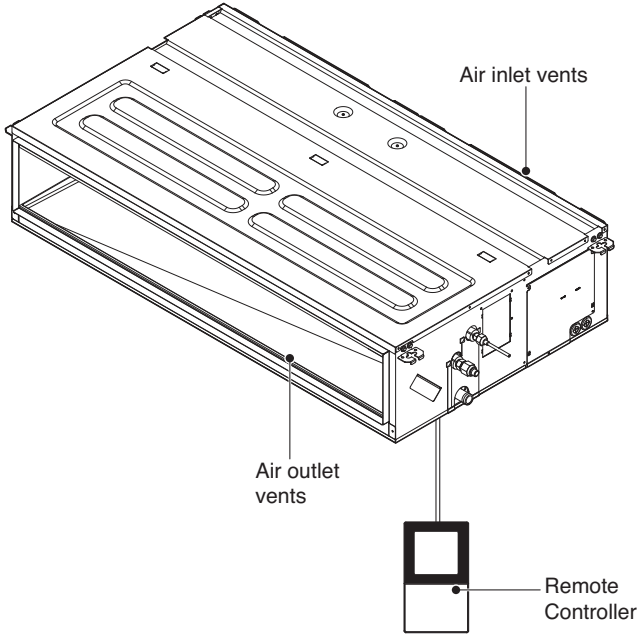
INTRODUCTION

Features



Name	Washer for hanging bracket	Clamp (Tie Wrap)	Insulation for fitting	Other
Quantity	8 EA	4 EA	1 set	
Shape			 for gas pipe  for liquid pipe	<ul style="list-style-type: none"> • Owner's manual • Installation manual

INSTALLATION OF INDOOR

Selection of the best location

Install the air conditioner in the location that satisfies the following conditions.

- The place shall easily bear a load exceeding four times the indoor unit's weight.
- The place shall be able to inspect the unit as the figure.
- The place where the unit shall be leveled.
- The place shall easily connect with the outdoor unit.
- The place where the unit is not affected by an electrical noise.
- The place where air circulation in the room will be good .
- There should not be any heat source or steam near the unit

Ceiling dimension and hanging bolt location

Install the unit above the ceiling correctly.

CASE 1

Position of suspension Bolt

- Apply a joint-canvas between the unit and duct to absorb unnecessary vibration.
- Apply a filter Accessory at air return hole.

Top view
Unit: mm

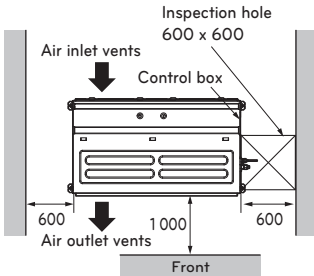

Front view
Unit: mm

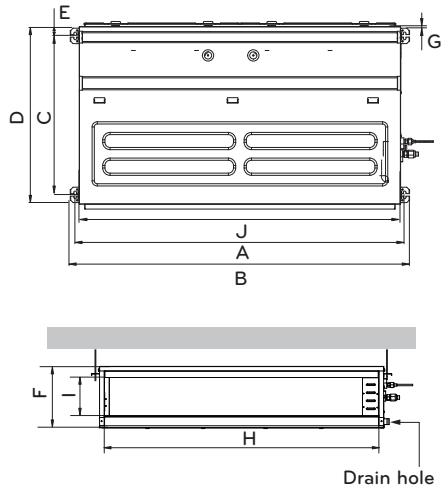
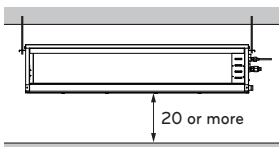

(Unit:mm)

Dimension	A	B	C	D	E	F	G	H	I	J
Chassis										
M1	933.4	971.6	619.2	700	30	270	15.2	858	201.4	900
M2	1 283.4	1 321.6	619.2	700	30	270	15.2	1 208	201.4	1 250
M3	1 283.4	1 321.6	619.2	700	30	360	15.2	1 208	291.4	1 250

Confirm the positional relationship between the unit and suspension bolts.

- Installation the ceiling opening to clean the filter or service under the product.

CASE 2

- Install the unit leaning to a drainage hole side as a figure for easy water drainage.

Position of console Bolt

- A place where the unit will be leveled and that can support the weight of the unit.
- A place where the unit can withstand its vibration.
- A place where service can be easily performed.

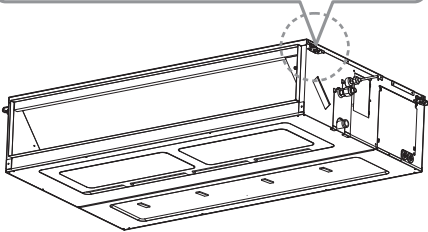
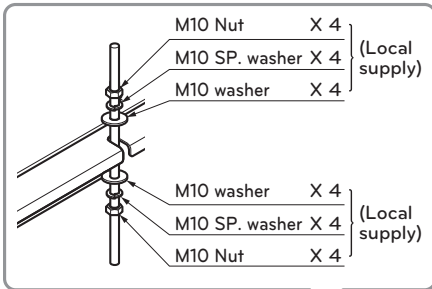

Select and mark the position for fixing bolts

- Drill the hole for set anchor on the face of ceiling.

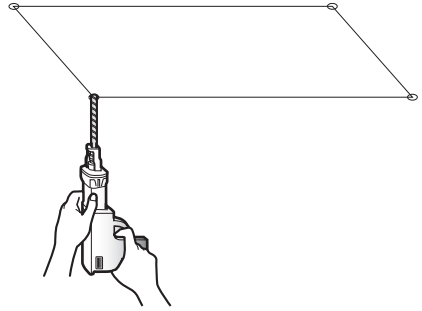

CAUTION

Tighten the nut and bolt to prevent unit falling.

- Insert the set anchor and washer onto the suspension bolts for locking the suspension bolts on the ceiling.
- Mount the suspension bolts to the set anchor firmly.
- Secure the installation plates onto the suspension bolts (adjust level roughly) using nuts, washers and spring washers.

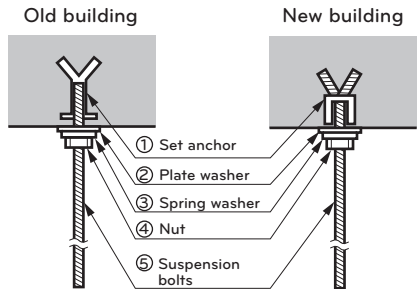

Wiring Connection

- Open the control box cover and connect the Remote controller wiring and Indoor power wires.
- Remove the control box cover for electrical connection between the indoor and outdoor unit.
- Use the cord clumper to fix the wiring.
- Pipes and wires should be purchased separately for installation of the product.

! CAUTION

The connecting wiring connected to the indoor and outdoor unit should be complied with the following specifications (This equipment shall be provided with a wiring set complying with the national regulation).

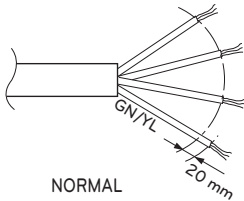

NORMAL
CROSS-SECTIONAL
AREA 0.75 mm²

Rated current of appliance A.	Nominal cross-sectional area mm ²
≤ 0.2	Tinsel cord
> 0.2 and ≤ 3	0.5
> 3 and ≤ 6	0.75
> 6 and ≤ 10	1.0 (0.75)
> 10 and ≤ 16	1.5 (1.0)
> 16 and ≤ 25	2.5
> 25 and ≤ 32	4
> 32 and ≤ 40	6
> 40 and ≤ 63	10

NOTE For **supply cords** supplied with multi-phase appliances, the nominal cross-sectional area of the conductors is based on the maximum cross-sectional area of the conductors per phase at the **supply cord** connection to the appliance terminals.

If the supply wiring is damaged, it must be replaced by a special wiring or assembly available from the manufacturer of its service agent.

! CAUTION

The Power cord connected to the unit should be selected according to the following specifications.

Precautions when laying power wiring

Use round pressure terminals for connections to the power terminal block.

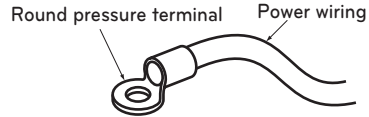

When none are available, follow the instructions below.

- Do not connect wiring of different thicknesses to the power terminal block. (Slack in the power wiring may cause abnormal heat.)
- When connecting wiring which is the same thickness, do as shown in the figure below.

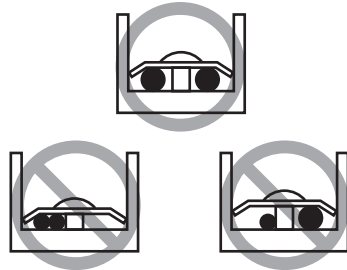

! CAUTION

- Install declination of the indoor unit is very important for the drain of the duct type air conditioner.
- Minimum thickness of the insulation for the connecting pipe shall be 5 mm.
- The unit must be horizontal or declined to the drain hose connected when finished installation.

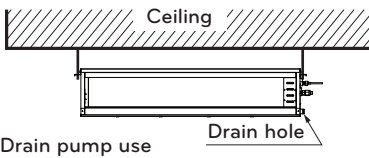
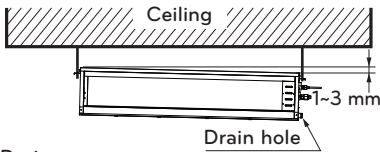

- Upward routing not allowed

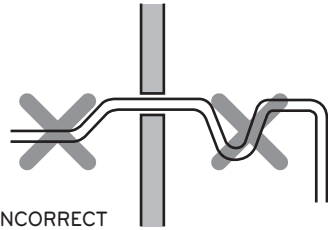
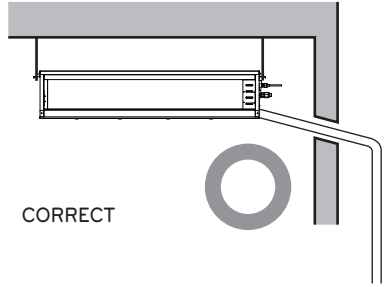

- Install the P-Trap (or U-Trap) to prevent a water leakage caused by the blocking of intake air filter.

Caution for gradient of unit and drain piping

Lay the drain hose with a downward inclination so water will drain out.

- Always lay the drain with downward inclination (1/50 to 1/100). Prevent any upward flow or reverse flow in any part.
- 5mm or thicker formed thermal insulator shall always be provided for the drain pipe.

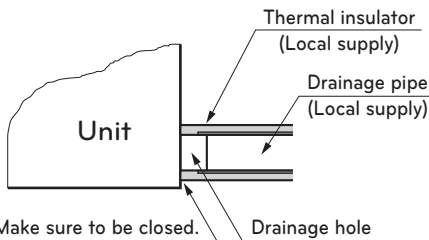
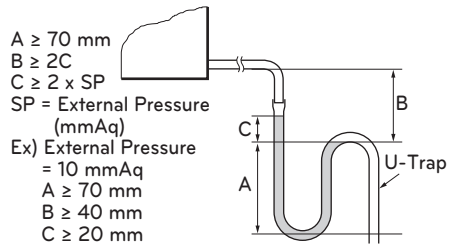

Indoor Unit Drain Piping

- Drain piping must have down-slope (1/50 to 1/100): be sure not to provide up-and-down slope to prevent reversal flow.
- During drain piping connection, be careful not to exert extra force on the drain port on the indoor unit.
- The outside diameter of the drain connection on the indoor unit is 32 mm.

Piping material: Polyvinyl chloride pipe VP-25 and pipe fittings

- Be sure to execute heat insulation on the drain piping.
- Install the drain raising pipes at a right angle to the indoor unit and no more than 300 mm from the unit.

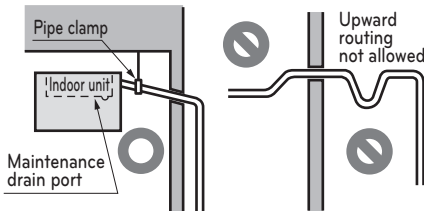

Heat insulation material: Polyethylene foam with thickness more than 8 mm.

Drain test

- Connect the main drain pipe to the exterior and leave it provisionally until the test comes to an end.
- Feed water to the flexible drain hose and check the piping for leakage.
- When the test is complete, connect the flexible drain hose to the drain port on the indoor unit.

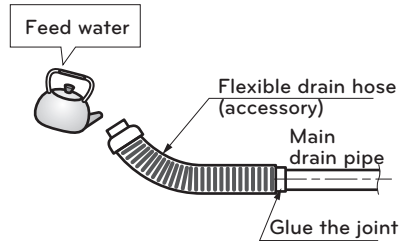

1 Remove the Air Filter.

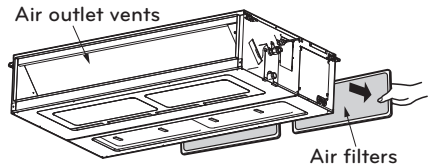

2 Check the drainage.

- Spray one or two glasses of water upon the evaporator.
- Ensure that water flows drain hose of indoor unit without any leakage.

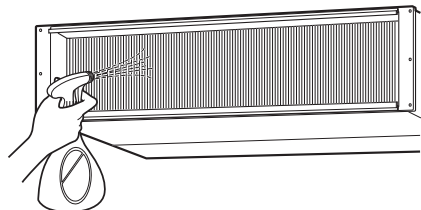

Heat insulation

- 1 Use the heat insulation material for the refrigerant piping which has an excellent heat-resistance (over 120 °C).
- 2 Precautions in high humidity circumstance:
This air conditioner has been tested according to the "KS Standard Conditions with Mist" and confirmed that there is not any default. However, if it is operated for a long time in high humid atmosphere (dew point temperature: more than 23 °C), water drops are liable to fall. In this case, add heat insulation material according to the following procedure:
 - Heat insulation material to be prepared... Adiabatic glass wool with thickness 10 to 20 mm.
 - Stick glass wool on all air conditioners that are located in ceiling atmosphere.

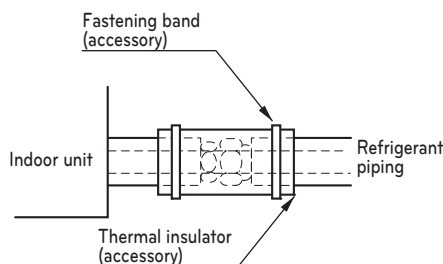

applies to	Insulation material standard (mm) (besides normal conditions for residential use)		Insulation material standard (mm) - residential		Insulation material standard (mm) (unfavorable conditions)
	Refrigerant piping dimensions (mm)	EPDM	If installed in an air-conditioned place (CASE 1) (ex: bedroom, living room, etc.)	If installed in a non-air-conditioned place (CASE 2) (ex: hallway, outdoors, etc.)	
Gas piping	6.35	19	13	19	19
	9.52	19	13	19	25
	12.7	19	13	19	25
	15.88	19	13	19	25
	19.05	19	13	19	25
	22.22	19	13	19	32
	25.40	19	19	19	32
	28.58	19	19	19	32
	31.75	19	19	19	32
	38.1	25	19	25	32
44.45	25	19	25	32	
Liquid piping	6.35	9	9	9	9
	9.52				
	12.7~44.45	13	13	13	13

- Normal conditions: Temperature of 30 °C, relative humidity of 85 %
- Unfavorable conditions: Temperature of 30 °C, relative humidity of 90 % (humid places such as bathrooms, swimming pools, etc.: air supply and exhaust fan installation)

REMOTE CONTROLLER INSTALLATION

- 1 Please fix tightly using provided screw after placing remote controller setup board on the place where you like to setup.
 - Please set it up not to bend because poor setup could take place if setup board bends.

Please set up remote controller board fit to the reclamation box if there is a reclamation box.

- 2 Can set up Wired remote controller cable into three directions.
 - Setup direction: the surface of wall reclamation, upper, right
 - If setting up remote controller cable into upper and right side, please set up after removing remote controller cable guide groove.

* Remove guide groove with long nose.

- ① Reclamation to the surface of the wall
- ② Upper part guide groove
- ③ Right part guide groove

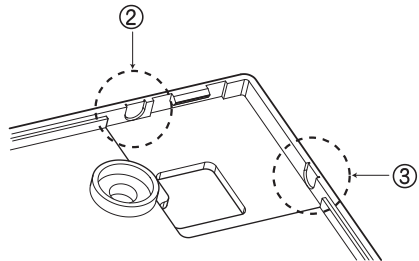
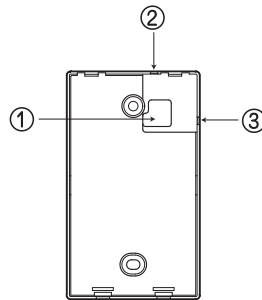
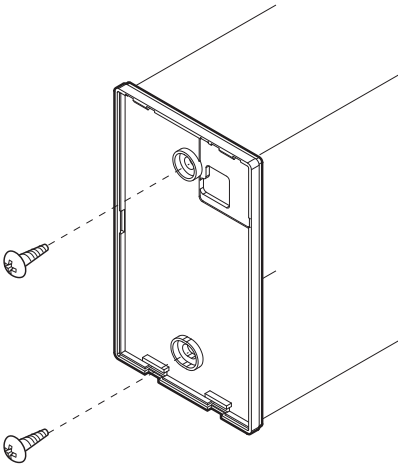

14 REMOTE CONTROLLER INSTALLATION

- 3 Please connect indoor unit and remote controller using connection cable.

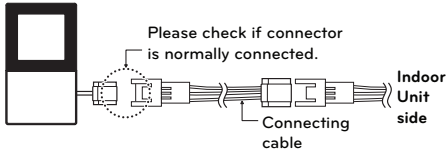

- 4 Please use extension cable if the distance between wired remote controller and indoor unit is more than 10 m.
- 5 Please fix remote controller upper part into the setup board attached to the surface of the wall, as the picture below, and then, connect with setup board by pressing lower part.
- Please connect not to make a gap at the remote controller and setup board's upper and lower, right and left part.

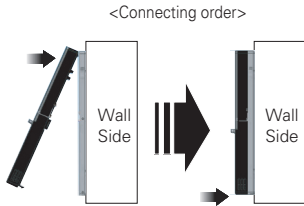

When separating remote controller from setup board, as the picture below, after inserting into the lower separating hole using screw driver and then, spinning clockwise, remote controller is separated.

- There are two separating holes. Please individually separate one at a time.
- Please be careful not to damage the inside components when separating.

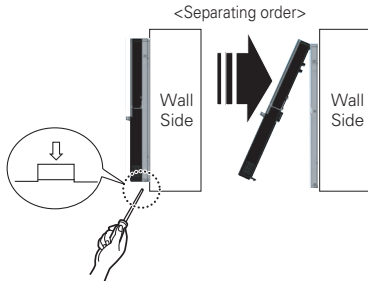

! CAUTION

When installing the wired remote controller, do not bury it in the wall. (It can cause damage in the temperature sensor.)

Do not install the cable to be 50 m or above. (It can cause communication error.)

- When installing the extension cable, check the connecting direction of the connector of the remote controller side and the product side for correct installation.
- If you install the extension cable in the opposite direction, the connector will not be connected.
- Specification of extension cable: 2547 1007 22# 2 core 3 shield 5 or above.

Group Control

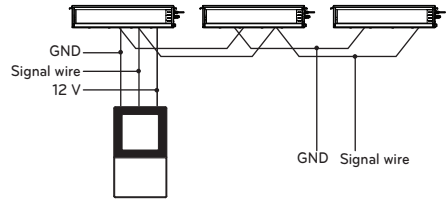

- 1 When installing more than 2 units of air conditioner to one wired remote controller, please connect as the right figure.
 - If it is not event communication indoor unit, set the unit as slave.
 - Check for event communication through the product manual.
- 2 When controlling multiple indoor units with event communication function with one remote controller, you must change the master/slave setting from the indoor unit.
 - Indoor units, the master/slave configuration of the product after completion of indoor unit power 'OFF' and then 'ON' the power after 1 minutes elapsed sign up.

- For ceiling type cassette and duct product group, change the switch setting of the indoor PCB.

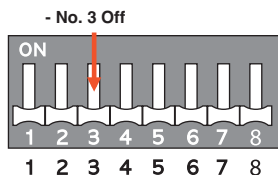

#3 switch OFF: Master
(Factory default setting)

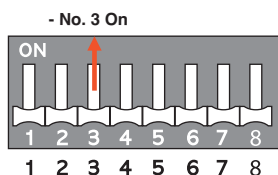

#3 switch ON: Slave

- For wall-mount type and stand type product, change the master/slave setting with the wireless remote controller. (Refer to wireless remote controller manual for detail)

* When installing 2 remote controllers to one indoor unit with event communication function, set the master/slave of the remote controller. (Refer to remote controller master/slave selection)

When controlling the group, some functions excluding basic operation setting, fan level Min/Mid/Max, remote controller lock setting and time setting may be limited.

- When installing more than 2 wired remote controllers to one air conditioner, please connect as the right picture.

- When installing more than 2 units of wired remote controller to one air conditioner, set one wired remote controller as master and the others all as slaves, as shown in the right picture.
- You cannot control the group as shown in the right for some products.
- Refer to the product manual for more detail.

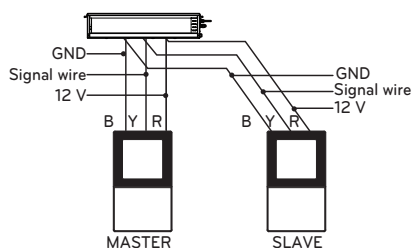

<When simultaneously connecting 2 sets of wired remote controller>

- When controlling in groups, set the master/slave of the remote controller. Refer to Installer setting section on how to set master/slave for more detail.

OPTIONAL OPERATION

Installer Setting - Test Run Mode

After installing the product, you must run a Test Run mode.

For details related to this operation, refer to the product manual.

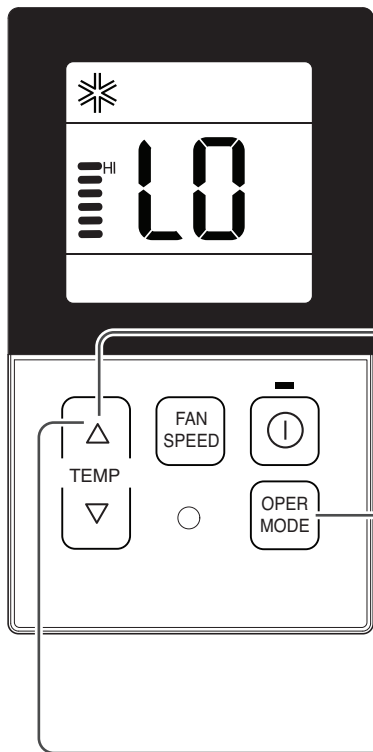

- 1** When pressing the button and button simultaneously for more than 3 seconds, the system will be entered into the installer setting mode.

 - After entering into the installer setting mode, select the test run mode code value by pressing the button.
 - * Test run mode code value : 01
- 2** When pressing the button, the test operation mode will be performed, and it is displayed as shown in the left figure.
- 3** When pressing the button and button simultaneously for more than 3 seconds after the setting has been completed, the setting mode will be released.

 - If there isn't any button input for more than 25 seconds, the installer setting mode will also be released.
- 4** When approx. 18 minutes are elapsed after starting of the test oper-mode, the system will be stopped automatically and converted to the standby state.

 - If any button is inputted during the test run mode, the test run mode will be forced to be released.

What is the test run mode?

- This means the operation of the product under the cooling, strong wind, and Comp on state without performing room temperature control in order to confirm the installed state during the product installation.

Installer Setting - Setting Address of Central Control

It's the function to use for connecting central control.

Please refer to central controller manual for the details

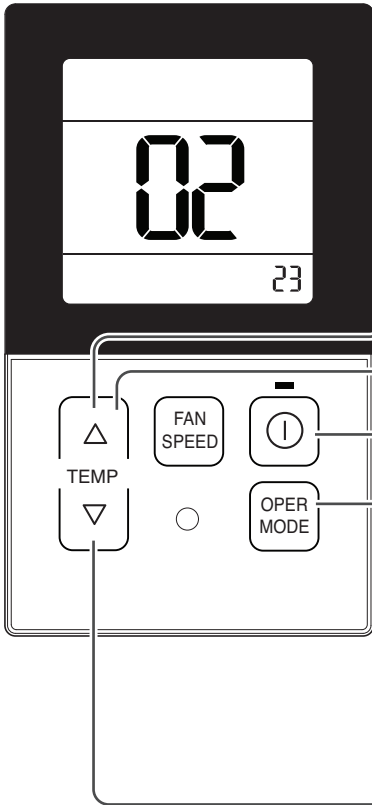

- 1** When pressing the button and button simultaneously for more than 3 seconds, the system will be entered into the installer setting mode.

 - After entering into the installer setting mode, select the central control address setting code value by pressing the .
 - * Setting address of central control code value : 02
- 2** Set up the group number and indoor unit with the temperature adjustment(,) buttons.

— Group number
 — Indoor unit number

For example, when setting as [Group number=2 Indoor number=3] it will be displayed as shown in the left figure.
- 3** When pressing the button, the system will be set up with the address value which has been established at present.
- 4** When pressing the button and button simultaneously for more than 3 seconds after the setting has been completed, the setting mode will be released.

 - If there isn't any button input for more than 25 seconds, the installer setting mode will also be released.

- If you connect the indoor unit to the central controller, you should set the network address of the indoor unit so that the central controller could recognize it.
- The center-control address is composed of the group number and the indoor-unit number.

! NOTE

The remote controller displays 'HL' if central controller has locked the remote controller .

* In the case when the lock is set up at the central controller, 'HL' will be indicated on the display window of the wired remote controller and the indoor unit will not be controlled by the remote controller.

Installer Setting - Thermistor

This is the function to select the temperature sensor to judge the room temperature.

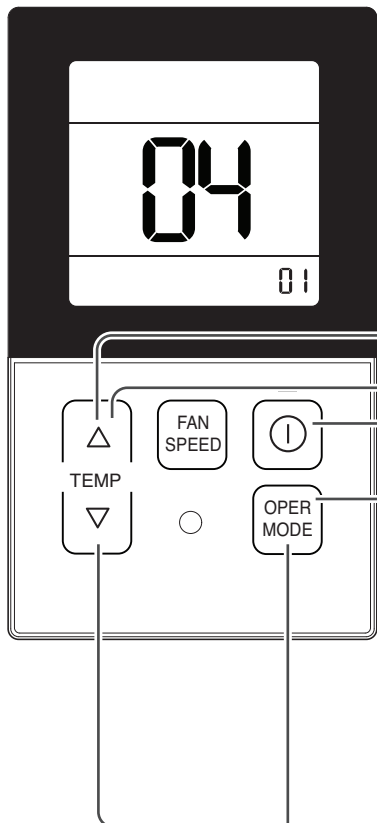

- 1 When pressing the button and button simultaneously for more than 3 seconds, the system will be entered into the installer setting mode.
- After entering into the installer setting mode, select the thermistor sensor setting code value by pressing the button.
* Thermistor sensor selection code value : 04

- 2 Select the desired setting value with the temperature up(), down()

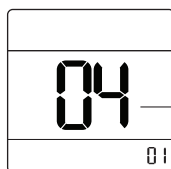

Code value
Value

*Setting value
01: Remote controller
02: Indoor unit
03: 2TH

- 3 When pressing the button, currently established thermistor sensor location will be set up.

- 4 When pressing the button and button simultaneously for more than 3 seconds after the setting has been completed, the setting mode will be released.
- If there isn't any button input for more than 25 seconds, the installer setting mode will also be released.

* As the characteristic of the '2TH' function can be different in accordance with the products, refer to the product instruction manual for its detail.

Installer Setting - Remote Controller Master/Slave Setup

It is a function for settings in group control, or 2-remote controller control.

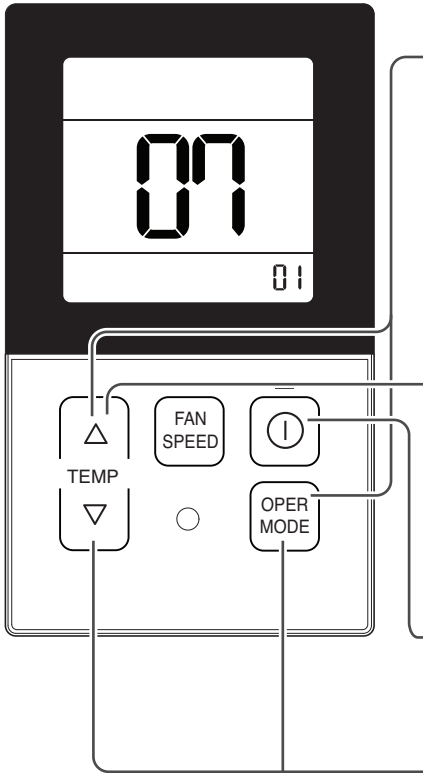

1 When pressing the Δ button and OPER MODE button simultaneously for more than 3 seconds, the system will be entered into the installer setting mode.

- After entering into the installer setting mode, select the ceiling height setting code value by pressing the oper-mode button.

* Remote controller master/slave setting code value : 07

2 Select the desired setting value with the temperature up(\blacktriangle), down(\blacktriangledown) button.

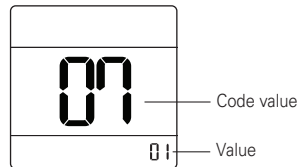

*Setting value
00:Slave
01:Master

3 When pressing the O button, currently established static pressure value will be set up.

4 When pressing the Δ button and OPER MODE button simultaneously for more than 3 seconds after the setting has been completed, the setting mode will be released.
- If there isn't any button input for more than 25 seconds, the installer setting mode will also be released.

Remote controller	Function
Master	Indoor unit operates based on master remote controller at group control. (Master is set when delivering from the warehouse.)
Slave	Setup all remote controllers except one master remote controller to slave at group control

* Refer to the 'group control' part for details

- When controlling in groups, basic operation settings, airflow strength weak/medium/strong, lock setting of the remote controller, time settings, and other functions may be restricted.

Installer Setting - Celsius / Fahrenheit Switching

This function is used for switching the display between Celsius and Fahrenheit.
(Optimized only for U.S.A)

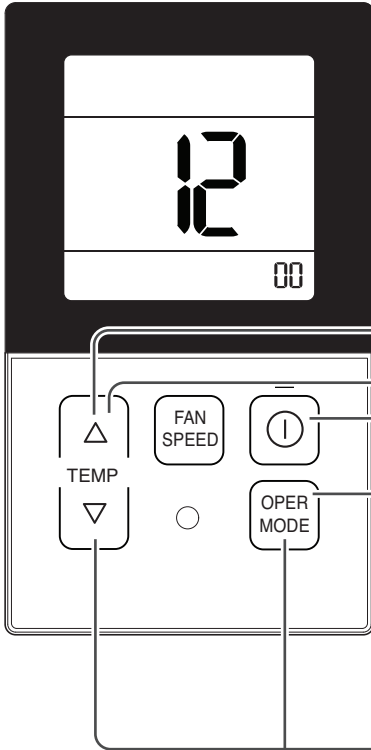

1 When pressing the button and button simultaneously for more than 3 seconds, the system will be entered into the installer setting mode.
- After entering into the installer setting mode, select the ceiling height setting code value by pressing the oper-mode button.
* Celsius/Fahrenheit setting code value : 12

2 Select the desired setting value with the temperature up() , down() button.



* Setting value
00:Celsius
01:Fahrenheit

Code value
Value

3 When pressing button, currently established celsius/Fahrenheit setting value will be set up.

4 When pressing the button and button simultaneously for more than 3 seconds after the setting has been completed, the setting mode will be released.
- If there isn't any button input for more than 25 seconds, the installer setting mode will also be released.

- Whenever press temp up() , down() button in Fahrenheit mode, the temperature will increase/drop 2 degrees.

Installer Setting - E.S.P.

This is the function that decides the strength of the wind for each wind level and because this function is to make the installation easier.

- If you set ESP incorrectly, the air conditioner may malfunction.
- This setting must be carried out by a certificated-technician.

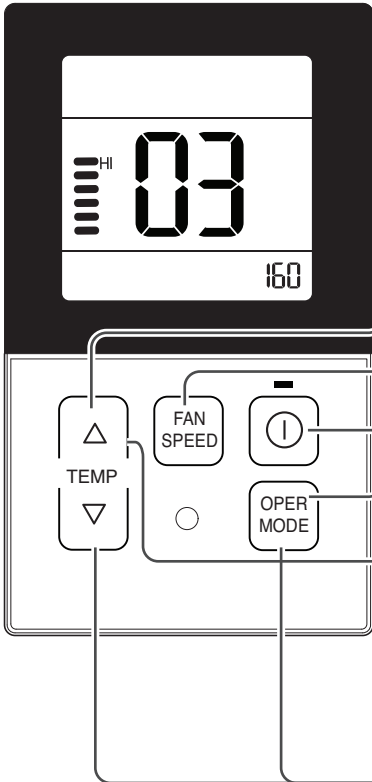

- 1 When pressing the button and button simultaneously for more than 3 seconds, the system will be entered into the installer setting mode.

 - After entering into the installer setting mode, select the E.S.P code value by pressing the button.
 - * E.S.P code value : 03
- 2 Select the desired air flow rate with the button. Whenever pressing the , [Lo→Med→Hi] will be indicated.
- 3 Select the desired air flow rate value with the temperature up(), down() button.

 - * E.S.P value range : 0~255
 - E.S.P value will be indicated at the lower right section of the display window.
- 4 When pressing the button, currently established E.S.P value will be set up.
- 5 When pressing the button and button simultaneously for more than 3 seconds after the setting has been completed, the setting mode will be released.

 - If there isn't any button input for more than 25 seconds, the installer setting mode will also be released.

- Precaution shall be taken not to alter the E.S.P value corresponded to each air flow section.
- E.S.P value can be varied according to the products.
- In the case of going to the next air flow rate stage by pressing the fan-speed button during the setup of the E.S.P value, the E.S.P value of previous air flow rate will be maintained by remembering the E.S.P value prior to the shift.

Installer Setting - Static Pressure Step Setting

This function is applied to only duct type. Setting this in other cases will cause malfunction.

This function is only available on some products.

This is the function that static pressure of the product is divided in 11 steps for setting.

1 When pressing the button and button simultaneously for more than 3 seconds, the system will be entered into the installer setting mode.

- After entering into the installer setting mode, select the static pressure step setting code value by pressing the button.
- * Static pressure step setting code value : 32

2 Select the desired setting value with the temperature up() , down() button.

Code value

Value

00: use static pressure (code 06) set value
01~ 11: static pressure step (code 32) set value

3 When pressing button, currently established static pressure value will be set up.

4 When pressing the button and button simultaneously for more than 3 seconds after the setting has been completed, the setting mode will be released.

- If there isn't any button input for more than 25 seconds, the installer setting mode will also be released.

- Static Pressure (Code 06) setting will not be used if Static Pressure Step (Code 32) setting is being used.

- For the static pressure value for each step, refer to the next page Table. 1

[Table. 1]

Capacity [Btu/h]	Step	CMM	Static Pressure[mmAq(Pa)]										
			2(20)	2.5(25)	3(29)	4(39)	6(59)	8(78)	10(98)	12(118)	13(127)	14(137)	15(147)
			Setting Value										
			32:01	32:02	32:03	32:04	32:05	32:06	32:07	32:08	32:09	32:10	32:11
18k	HIGH	16.5	85	86	88	92	99	106	115	122	126	130	133
	MID	14.5	75	77	85	88	93	102	111	118	121	126	129
	LOW	13	71	73	76	85	89	98	107	114	117	122	125

Capacity [Btu/h]	Step	CMM	Static Pressure[mmAq(Pa)]										
			2(20)	2.5(25)	3(29)	4(39)	6(59)	8(78)	10(98)	12(118)	13(127)	14(137)	15(147)
			Setting Value										
			32:01	32:02	32:03	32:04	32:05	32:06	32:07	32:08	32:09	32:10	32:11
24k	HIGH	18	94	96	101	106	109	115	121	126	131	134	137
	MID	16.5	89	91	96	101	105	111	117	122	126	130	133
	LOW	14	79	81	87	93	99	105	112	117	121	125	129

Capacity [Btu/h]	Step	CMM	Static Pressure[mmAq(Pa)]										
			4(39)	5(50)	6(59)	7(69)	8(78)	9(88)	10(98)	11(108)	12(118)	13(127)	15(147)
			Setting Value										
			32:01	32:02	32:03	32:04	32:05	32:06	32:07	32:08	32:09	32:10	32:11
36k	HIGH	32	97	103	107	111	115	117	119	123	126	130	137
	MID	28	91	96	101	105	109	112	115	118	122	125	131
	LOW	23	80	89	93	98	104	107	111	114	118	121	127

Capacity [Btu/h]	Step	CMM	Static Pressure [mmAq(Pa)]										
			5(50)	6(59)	7(69)	8(78)	9(88)	10(98)	12(118)	14(137)	15(147)	16(157)	18(177)
			Setting Value										
			32:01	32:02	32:03	32:04	32:05	32:06	32:07	32:08	32:09	32:10	32:11
48k	HIGH	40	88	90	93	96	99	102	108	113	115	117	121
	MID	34	80	87	88	91	94	97	103	109	111	112	117
	LOW	28	75	79	80	88	90	93	99	105	107	109	114

Capacity [Btu/h]	Step	CMM	Static Pressure [mmAq(Pa)]										
			4(40)	5(50)	6(59)	7(69)	8(78)	9(88)	10(98)	11(108)	12(118)	13(127)	14(137)
			Setting Value										
			32:01	32:02	32:03	32:04	32:05	32:06	32:07	32:08	32:09	32:10	32:11
54k	HIGH	50	94	97	98	103	107	109	112	114	117	119	121
	MID	45	89	93	94	98	102	104	106	109	112	114	117
	LOW	40	83	84	90	93	98	99	102	105	108	110	113

! NOTE

1. Be sure to set the value referring table 1. Unexpected set value will cause mal-function.
2. Table 1 is based at 230 V. According to the fluctuation of voltage, air flow rate varies.
3. Factory Set(External Static Pressure) each Model

Capacity [Btu/h]	Factory set (E.S.P.) mmAq(Pa)	Lower Limit (E.S.P) mmAq(Pa)	Upper Limit (E.S.P) mmAq(Pa)
18k	8(78)	2(20)	10(98)
24k	8(78)	2(20)	10(98)
36k	10(98)	4(39)	10(98)
48k	6(59)	5(49)	14(137)
54k	6(59)	4(39)	14(137)

* If it is zero static pressure, please set value below Maximum value.

Capacity [Btu/h]	Maximum Value
18k	106
24k	115
36k	119
48k	90
54k	98

Capacity [Btu/h]	Step	CMM	Static Pressure[mmAq(Pa)]										
			2(20)	2.5(25)	3(29)	4(39)	6(59)	8(78)	10(98)	12(118)	13(127)	14(137)	15(147)
			Setting Value										
			1step	2step	3step	4step	5step	6step	7step	8step	9step	10step	11step
22k	HIGH	16.5	85	87	90	94	103	110	118	125	128	131	134
	MID	14.5	76	77	85	91	97	107	114	121	125	128	131
	LOW	13	73	74	77	88	93	103	111	117	120	125	128
30k	HIGH	18	90	92	95	99	108	115	122	129	132	135	138
	MID	16.5	85	87	90	94	103	111	118	125	128	131	134
	LOW	14.5	76	77	85	89	97	106	114	121	124	127	130

Capacity [Btu/h]	Step	CMM	Static Pressure[mmAq(Pa)]										
			2.5(25)	3(29)	4(39)	5(49)	6(59)	7(69)	8(78)	9(88)	11(108)	12(118)	15(147)
			Setting Value										
			1step	2step	3step	4step	5step	6step	7step	8step	9step	10step	11step
40k	HIGH	30	66	69	71	76	80	84	86	91	97	101	105
	MID	25	62	65	67	72	76	80	82	87	92	97	101
	LOW	20	58	61	63	68	72	76	78	83	88	92	97

Capacity [Btu/h]	Step	CMM	Static Pressure[mmAq(Pa)]										
			4(39)	5(49)	6(59)	7(78)	8(78)	9(88)	10(98)	11(108)	12(118)	13(127)	15(147)
			Setting Value										
			1step	2step	3step	4step	5step	6step	7step	8step	9step	10step	11step
50k	HIGH	40	83	89	92	94	98	100	102	105	108	110	116
	MID	34	78	82	84	89	94	96	98	101	104	106	112
	LOW	28	74	76	79	82	89	92	94	96	99	102	107
60k	HIGH	50	94	97	100	104	107	109	112	115	117	119	121
	MID	45	90	92	96	98	102	104	106	109	112	114	117
	LOW	40	82	89	92	94	98	100	102	105	108	110	113

! NOTE

1. Be sure to set the value referring table 1. Unexpected set value will cause mal-function.
2. Table 1 is based at 220-240 V. According to the fluctuation of voltage, air flow rate varies.
3. Factory Set(External Static Pressure) each Model

Capacity [Btu/h]	Factory set (E.S.P.) mmAq(Pa)	Lower Limit (E.S.P.) mmAq(Pa)	Upper Limit (E.S.P.) mmAq(Pa)
22k	6(59)	2(20)	15(147)
30k		2(20)	15(147)
40k		2.5(25)	15(147)
50k		4(39)	15(147)
60k		4(39)	15(147)

* If it is zero static pressure, please set value below Maximum value.

Capacity [Btu/h]	Maximum value
22k	115
30k	
40k	98
50k	
60k	

Installer Setting - Auto ESP

This function automatically sets the rotation speed of the fans corresponding to each step of rated airflow for easy installation.

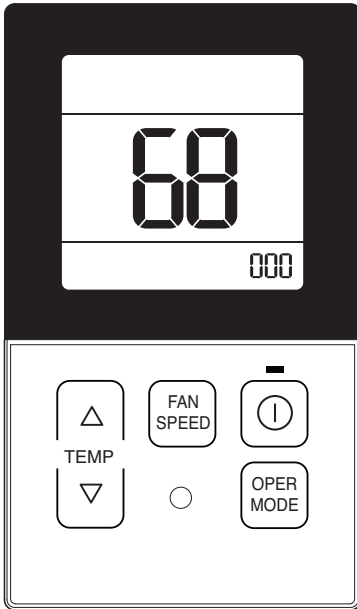

- 1** When pressing the button and button simultaneously for more than 3 seconds, the system will be entered into the installer setting mode.

 - If button is pressed repeatedly, it is moved to Auto ESP setting menu as the picture below.
 - * Code value : 68
- 2** Set the auto ESP mode using the Temperature button and set the manual step using the Fan speed button.
- 3** Press button to save the setting.
- 4** When pressing the button and button simultaneously for more than 3 seconds after the setting has been completed, the setting mode will be released.

 - If there isn't any button input for more than 25 seconds, the installer setting mode will also be released.

- ※ The voltage can be set by setting the Auto ESP Mode to 'Manual (2)', then pressing the 'Fanspeed' button.
- ※ While 'Auto ESP' is being set, the display on the wired remote control changes as shown below, and the wired remote control cannot be operated.
- ※ Once the set-up is complete, you can enter installer setup (68) to check whether the set-up has succeeded or failed. (3: Success, 4: Failure)

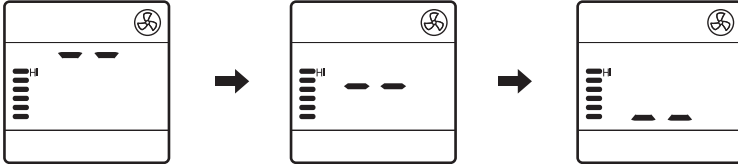

Value 1 (Auto ESP mode)	Value 2 (Manual Step)	Description (Voltage setting)
0 (Not use)	-	-
1 (Auto)	-	-
2 (Manual)	00	190 V
	01	200 V
	02	210 V
	03	220 V
	04	230 V
	05	240 V
	06	250 V
	07	260 V
	08	270 V
3	-	Cannot be set, only monitoring is possible. If the value1 is 3, setting is successful.
4	-	Cannot be set, only monitoring is possible. If the value1 is 4, setting has failed.

! NOTE

If this function is incorrectly set especially, in case of mismatching the voltage, the air conditioner may malfunction.

this function must be set by the installation specialist that holds an installation license. (please check the product type)

This function is only available on some products.

! NOTE

- If the heat exchanger is not dry, please set the device to operate in air circulation mode for 15 minutes.
- The air filter must be properly attached to the suction side of the product.
- Adjust the dampers so that each air inlet and outlet exhaust the required air.
- Please do not use the set auto air flow function when using various booster fans (outdoor air treatment device or ERV through ducts).
- Please reinitiate the set auto air flow function if the duct shape has changed since its initial installation.
- When setting the voltage manually, the set air flow will differ from the actual air flow if the set voltage is different from the actual voltage.
- When setting voltage manually, measure the actual voltage and select the set voltage on the remote control.
- Failure to follow the above method may cause the actual air flow to differ from the rated air flow.

DIP SWITCH SETTING

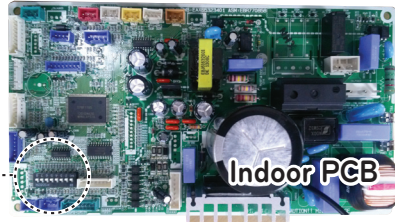
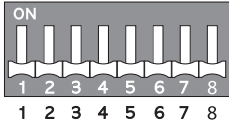

	Function	Description	Setting Off	Setting On	Default
SW3	Group Control	Selection of Master or Slave	Master	Slave	Off
SW4	Dry Contact Mode	Selection of Dry Contact Mode	Wired/Wireless remote controller Selection of Manual or Auto operation Mode	Auto	Off
SW5	Installation	Fan continuous operation	Continuous operation Removal	Working	Off

