



Scan the QR code to see the manual.



OWNER'S MANUAL

BUILT-IN OVEN



Before beginning installation, read these instructions carefully. This will simplify installation and ensure that the product is installed correctly and safely. Leave these instructions near the product after installation for future reference.

ENGLISH

WSED7613*, WS7D7610*



MFL71927512
Rev.07_110525

www.lg.com

Copyright © 2023-2025 LG Electronics. All Rights Reserved

TABLE OF CONTENTS

This manual may contain images or content that may be different from the model you purchased.
This manual is subject to revision by the manufacturer.

IMPORTANT SAFETY INSTRUCTIONS

- READ ALL INSTRUCTIONS BEFORE USE 5**
 - Safety Messages.....5
- WARNING 6**
 - Installation6
 - Operation7
 - Maintenance9
 - Risk of Fire and Flammable Materials.....10
- CAUTION..... 11**
 - Operation11
 - Maintenance12
- CARING FOR THE ENVIRONMENT 13**
 - Disposal13
 - Used Appliances14
- INSTALLATION INSTRUCTIONS..... 14**
 - Safety Instructions for the Installer15
 - Electrical connection.....15

PRODUCT OVERVIEW

- Product Features 17**
 - Exterior / Interior17
 - Accessories.....18

OPERATION

- Operating Control Panel 19**
 - Control Panel Features19
 - Energy Saving Tips21
- Changing Settings 21**
 - Settings (InstaView, Clock, Volume).....21
 - Setting a Cook Mode.....22
 - Control Lock22
 - Oven Light.....22
 - Wi-Fi22

Remote Start	22
Demo Mode	23
Operating the Oven	23
Before Using the Oven	23
Assembling Rail (Telescopic) Rack.....	24
Removing Rail Rack.....	24
Using the Telescopic Runners	25
Using Standard Oven Racks.....	25
InstaView.....	25
Manual Cook.....	26
Baking.....	31
Recommended Baking Guide	32
Hot Air / Economic Hot Air	37
Recommended Economic Hot Air Guide	38
Grilling	38
Recommended Grilling Guide	40
Defrosting	41
Roasting.....	41
Recipe Cook Mode	43
Air Fry.....	55
Recommended Air Frying Guide	57
Air Sous-Vide.....	60
Recommended Air Sous-Vide Guide.....	61
Information for Test Institutes	61

SMART FUNCTIONS

LG ThinQ Application	63
LG ThinQ Application Features	63
Installing LG ThinQ Application and Connecting an LG Appliance.....	63
Open Source Software Notice Information	64
Smart Diagnosis Feature	64
Using LG ThinQ to Diagnose Issues.....	64
Using Audible Diagnosis to Diagnose Issues	64

MAINTENANCE

Cleaning.....	66
Interior.....	66
Exterior	66
EasyClean	67
Pyrolysis (Model WSED7613*)	69
Periodic Maintenance	72

Changing the Oven Light	72
Removing, Assembling and Dismantling the Oven Door	72

TROUBLESHOOTING

FAQs	76
Frequently Asked Questions.....	76
Before Calling for Service	77
Cooking	77
Parts & Features	78
Noises	79
Wi-Fi	80
Customer Service & Spare Parts.....	80
After Sales Service (Egypt Only).....	81

IMPORTANT SAFETY INSTRUCTIONS

READ ALL INSTRUCTIONS BEFORE USE

Safety Messages

Your safety and the safety of others are very important.

We have provided many important safety messages in this manual and on your appliance. Always read and follow all safety messages.

Read and follow instructions when you use the appliance to avoid fire risks, electric shock, bodily injuries or damage. This guide does not include all possible situations that could happen. Always contact your technical service agent or the manufacturer when any incomprehensible problem appears. These instructions are only valid if the country symbol appears on the appliance. If the symbol does not appear on the appliance, it is necessary to refer to the technical instructions which will provide the necessary instructions concerning modification of the appliance to the conditions for use in the country.



This is the safety alert symbol.

This symbol alerts you to potential hazards that can kill or injure you and others. All safety messages will follow the safety alert symbol and either the word **WARNING** or **CAUTION**.

These words mean:



WARNING

You may be killed or seriously injured if you do not follow instructions.



CAUTION

You may be injured or cause damage to the product if you do not follow instructions.

All safety messages will tell you what the potential hazard is, tell you how to reduce the chance of injury, and tell you what may happen if the instructions are not followed.

WARNING

WARNING

- To reduce the risk of explosion, fire, death, electric shock, injury or scalding to persons when using this product, follow basic precautions, including the following:
-

Installation

- Never allow anyone to climb, sit, stand or hang on the oven door. Injury might result from contact with hot food or the oven itself.
- Do not line the oven walls, racks, bottom, or any other part of the oven with aluminum foil or any other material. Doing so will disrupt heat distribution, produce poor baking results and cause permanent damage to the oven interior (aluminum foil will melt to the interior surface of the oven).
- Do not use aluminum foil or any other material to line the oven bottom. Improper installation of oven liners may result in a risk of electric shock or fire.
- Make sure your appliance is properly installed and grounded by a qualified installer, according to the installation instructions. Any adjustment and service should be performed only by qualified installers or service technicians.
- Be certain that all packing materials are removed from the appliance before operating. Keep plastic, clothes, paper, and other flammable materials away from parts of the appliance that may become hot.
- The electrical power must be shut off while the electrical connections are being made.
- Improper connection of aluminum house wiring to copper leads can result in an electrical hazard or fire. Use only connectors designed for joining copper to aluminum and follow the manufacturer's recommended procedure closely.
- Do not open or close the oven door by foot using excessive force.
- Do not obstruct vent hole with tissue.
- Do not use the oven to dry a live animal.

- Do not place, store, or cook any living animals or organism in the oven.
- Do not use the oven for firing of pottery or curing of painted items.
- The appliance must not be installed behind a decorative door in order to avoid overheating.
- Do not install the appliance on the floor.
- Ensure that the appliance is switched off before replacing the lamp to avoid the possibility of electric shock.

Operation

- Do not use this oven for Commercial applications. This oven is exclusively and intended for Domestic use only.
- **DO NOT TOUCH HEATING ELEMENTS OR INTERIOR SURFACES OF THE OVEN.** Heating elements may be hot even though they are dark in color. Interior surfaces of an oven become hot enough to cause burns. During and after use, do not touch or let clothing or other flammable materials contact heating elements or interior surfaces of the oven until they have had sufficient time to cool. Other surfaces, such as oven vent openings and surfaces near these openings, oven doors, and windows of oven doors, also get hot and may cause burns if not allowed to cool.
- Use care when opening the door. The hot air and steam that escape can cause burns to hands, face and eyes. Let hot air or steam escape from the oven before removing or replacing food in the oven.
- Do not use plastic to cover food. Use foil or oven-safe lids only.
- Never attempt to dry a pet in the oven.
- Never use your appliance for warming or heating the room.
- Always use pot holders or oven mitts when removing food from an oven. Cookware will be hot. Use only dry pot holders. Moist or damp pot holders on hot surfaces may result in burns from steam. Do not let the pot holder touch hot heating elements. Do not use a towel or other bulky cloth to remove food.
- Do not heat unopened food containers. Pressure in the containers may cause them to burst which may result in injury.

8 IMPORTANT SAFETY INSTRUCTIONS

- Do not allow aluminum foil or the temperature probe to contact heating elements.
- Do not touch the oven racks while they are hot.
- If a rack must be moved while the oven is hot, do not let the pot holder contact the hot heating element in the oven.
- Pull the oven rack to the stop-lock position when loading and unloading food from the oven. This helps prevent burns caused by touching hot surfaces of the door and oven walls.
- Do not use the oven if a heating element develops a glowing spot during use or shows other signs of damage. A glowing spot indicates the heating element may fail and present a potential burn, fire, or shock hazard. Turn the oven off immediately and have the heating element replaced by a qualified service technician.
- DO NOT block the oven vent during operation. This can damage the electric parts of the oven. Air must be able to circulate freely. The bottom vent trim should be properly assembled on the front bottom of the oven before installing the oven door.
- Do not put large, heavy items such as whole turkeys on the open oven door.
- Take care when the door is open to avoid injury.
- If the door or door seals are damaged, the oven must not be operated until it has been repaired by a competent qualified person.
- Do not allow children to crawl into the oven.
- Do not put your hand under the controller or between the door and bottom vent trim during operation. The outside of the oven can become very hot to the touch.
- This appliance can be used by children aged from 8 years and above and persons with reduced physical, sensory or mental capabilities or lack of experience and knowledge if they have been given supervision or instruction concerning use of the appliance in a safe way and understand the hazards involved. Children shall not play with the appliance. Cleaning and user maintenance shall not be made by children without supervision.

- Young children should be supervised to ensure that they do not play with the appliance.
- During use, the appliance becomes hot. Care should be taken to avoid touching heating elements inside the oven. Young children should be kept away.
 - These surfaces may be hot enough to burn skin even after cooking is finished, though they may not appear to be so, avoid placing hands and arms inside the oven.
- Accessible parts may become hot during use. Young children should be kept away.
- Exposed parts of the oven can become hot during grilling. Keep children at a distance.
- The instructions shall state that under such conditions the surfaces may get hotter than usual and children should be kept away.

Maintenance

- Do not store items of interest to children on the back guard or in cabinets above a cooking appliance. Children climbing on the oven to reach items could be seriously injured.
- Let hot cookware and utensils cool in a safe place, out of reach of small children.
- If the door glass, surface, or oven heating unit of the appliance are damaged, discontinue use of the appliance and call for service.
- Always disconnect power from the appliance before servicing.
- Before replacing the oven light, switch off the electrical power to the oven at the main fuse or circuit breaker panel.
- Never pour cold water over a hot oven for cleaning purposes.
- Do not clean with metal scouring pads. Pieces can burn off the pad and touch electrical parts causing a risk of electric shock.
- Do not store any materials, other than manufacturer's recommended accessories, in this oven when not in use.
- Do not cover racks or any other part of the oven with metal foil. This will cause overheating of the oven.

- If the oven is heavily soiled with oil, pyrolyze the oven before using the oven again. The oil could cause a fire.
- If there is a fire in the oven during pyrolysis, turn the oven off and wait for the fire to go out. Do not force the door open. Introduction of fresh air at pyrolysis temperatures may lead to a burst of flame from the oven. Failure to follow this instruction may result in severe burns.
- If your oven is dropped or damaged, have it thoroughly checked by a qualified service technician before using it.
- If the supply cord is damaged, it must be replaced by the manufacturer, its service agent or similarly qualified persons in order to avoid a hazard. (on some models only)
- **DO NOT TOUCH HEATING ELEMENTS OR INTERIOR SURFACES OF OVEN CAVITY.** During and after use or cleaning the interior, do not touch other flammable materials contact heating elements or interior surfaces of oven cavity until they have had sufficient time to cool. Other surfaces, such as windows of oven door, oven lamp, also get hot and may cause burns if not allowed to cool.

Risk of Fire and Flammable Materials

- Do not store or use flammable material in or near the oven. Flammable materials include paper, plastic, pot holders, linens, wall coverings, curtains, and gasoline or other flammable vapors and liquids such as grease or cooking oil. These materials can ignite when the oven is in use.
- Use extreme caution when moving or disposing of hot grease.
- Wear proper apparel. Do not wear loose-fitting or hanging garments, which may ignite if they contact hot surfaces, and cause severe burns.
- Do not use the oven for drying clothes. Only use the oven for its intended purpose.
- If cabinet storage is provided directly above the oven, use it to store items that are not frequently used and can be safely stored in an area subjected to heat. Temperatures may be unsafe for volatile items such as flammable liquids, cleaners or aerosol sprays.

- Do not use water on grease fires. Should an oven fire occur, leave the oven door closed and turn the oven off. If the fire continues, throw baking soda on the fire or use a fire extinguisher. Do not put water or flour on the fire. Flour may be explosive and water can spread a grease fire and cause personal injury.

CAUTION

Operation

- Always heat fat slowly, and watch as it heats.
- If frying combinations of oils and fats, stir them together before heating.
- Use a deep fat thermometer, if possible, to prevent overheating fat beyond the smoking point.
- Use the least possible amount of fat for effective shallow or deep-fat frying. Filling the pan with too much fat can cause spillovers when food is added.
- Accessible parts may become hot when the grill is in use.
- When using cooking or roasting bags in the oven, follow the manufacturer's directions.
- The door or the outer surface may get hot when the appliance is operating.
- Do not use this oven for purposes other than cooking.
- Use caution if opening the door when the oven is operating. Hot surfaces can cause serious burns.
- In order to avoid a hazard due to inadvertent resetting of the thermal cut-out, this appliance must not be supplied through an external switching device, such as a timer, or connected to a circuit that is regularly switched on and off by the utility.
- Excess spillage must be removed before cleaning.
- When using cleaning mode, remove the baking tray, deep baking tray, wire grill, all cookware, aluminum foil, or any other material from the oven.

Maintenance

- Do not repair or replace any part of the appliance unless specifically recommended in the manual. All other servicing should be performed by a qualified technician.
- Do not use harsh etching, abrasive cleaners or sharp metal scrapers to clean the oven door glass since they can scratch the surface. Scratches may cause the glass to shatter.
- Make sure oven lights are cool before cleaning.
- Do not clean the door gasket. The door gasket is essential for a good seal. Care should be taken not to rub, damage, or move the gasket.
- Do not rinse trays and racks by placing them in water just after cooking. This may cause breakage or damage.
- The oven should be cleaned regularly and any food deposits should be removed. Failure to maintain the oven in a clean condition could lead to deterioration of the surface that could shorten the life of the appliance and possibly result in a hazardous situation.
- Never use oven cleaner in the cooking compartment when it is still warm, and never heat up the oven unless all oven cleaner has been wiped off.
- Do not clean the accessories in a dishwasher.
- Do not use oven cleaners, steam cleaners, harsh chemical cleaners, bleach, vinegar, steel scouring pads, or abrasive pads or cleansers to clean the oven, as they can permanently damage the oven surface.

CARING FOR THE ENVIRONMENT

Disposal

CAUTION

- Your new oven has been correctly packaged for transportation. Remove all of the packaging material before putting the appliance into use.
- Do not forget to remove the foils from the telescoping runners and from the panel.

Single material of packaging

Packaging material		Alphabetical	Numerical
Plastic	Polyethylene terephthalate	PET	1
	High-density polyethylene	HDPE	2
	Polyvinylchloride	PVC	3
	Low-density polyethylene	LDPE	4
	Polypropylene	PP	5
	Polystyrene	PS	6
Paper & Cardboard	Corrugated board	PAP	20
	Another board	PAP	21
	Paper	PAP	22
Metals	Steel	FE	40
	Aluminum	ALU	41

Packaging material		Alphabetical	Numerical
Wood	Wood	FOR	50
	Cork		51
Textile	Cotton	TEX	60
	Jute		61
Glass	Clear glass	GL	70
	Green glass		71
	Brown glass		72

- If you wish to store your oven away temporarily, choose a dry, dust-free place. Dust and damp may adversely affect the working parts in the oven.

Used Appliances

CAUTION

- Used appliances must be rendered unusable prior to disposal so that they no longer present a risk. To achieve this, disconnect from the mains supply and remove the power supply cable.

For the protection of the environment, used appliances must be disposed of properly.

- The appliance must not be disposed of along with normal domestic waste.

INSTALLATION INSTRUCTIONS

Installation should be undertaken by a qualified professional electrician only.

Safety Instructions for the Installer

The oven must be installed in compliance with the manufacturer's instructions. For more information about installation, please refer to the installation manual.

- Do not install the appliance if there is a transport damage. Contact an LG Electronics customer information centre.
- During installation, ensure that no persons can come into contact with live components.
- The oven must be installed by a qualified professional electrician, in accordance with the corresponding regulations and standards.
- The oven is a heavy appliance and must be transported with great care at least by two persons.
- Before initial use, remove all packaging, both external and from inside the appliance.
- No modification may be made to the oven's technical characteristics.
- Disconnect the electrical power to the appliance at the main fuse or circuit breaker panel. Failure to do so can result in severe personal injury, death, or electrical shock.
- Make sure to slide the tray and wire grill in a correct position as the telescopic runner pins are inserted through the holes on both sides.

Electrical connection

The range should always be plugged into its own individual properly grounded electrical outlet.

- This prevents overloading house wiring circuits which could cause a fire hazard from overheated wires.
- It is recommended that a separate circuit serving only this appliance be provided.
- Connection of this appliance must comply with national and local safety regulations.
- Connection to a switched socket is recommended as this provides easier access in the case of a service call.

- For extra safety, it is advisable to protect the appliance with a suitable residual current device (RCD) with a trip current of 30 mA.
- If the switch is not accessible after installation an additional means of disconnection must be provided for all poles. The means of disconnection must be incorporated in the fixed wiring in accordance with the wiring rules.
- When switched off there must be an all pole contact gap of 3 mm in the isolator switch (including switch, fuses and relays).
- Connection data
 - Blue : Neutral Wire
 - Green + Yellow : Ground Wire
 - Brown : Live Wire
 - The voltage and rated load are given on the data plate situated at the front of the oven frame visible with the oven door open. Please ensure the connection data matches the household supply.
- This appliance incorporates an earth connection for functional purposes.

PRODUCT OVERVIEW

Product Features

Exterior / Interior

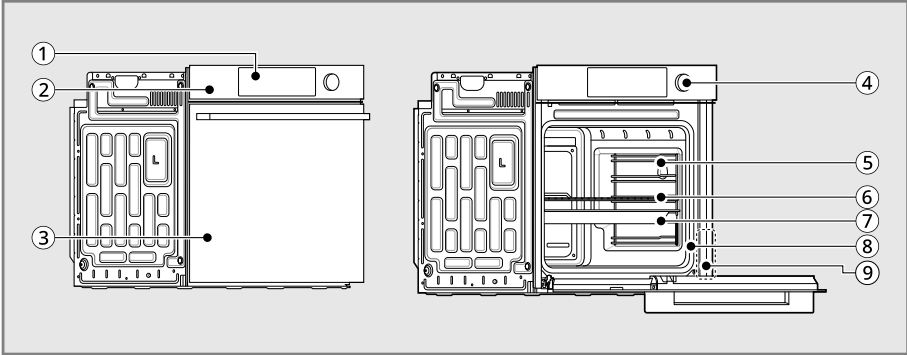

①	Display	⑥	Wire Grill
②	Oven Controller	⑦	Baking Tray
③	Oven Door	⑧	Gasket
④	Oven Control Knob	⑨	Rating Label, Model and Serial Number Plate
⑤	Rail Rack (2 ea)	-	-

NOTE

- The model and serial number can be verified at the rating label.

Accessories

⚠ CAUTION

- After installation pull off the protection film from the panel as well as from the telescopic runners.

NOTE

- Contact your LG Electronics customer information center if any accessories are missing for your particular model.
 - Please find the contact data of all countries in the enclosed warranty card.
- For your safety and for extended product life, only use authorized components.
- The manufacturer is not responsible for product malfunction or accidents caused by the use of separately purchased, unauthorized components or parts.
- The images in this guide may be different from the actual components and accessories, which are subject to change by the manufacturer without prior notice for product improvement purposes.

Accessories for Cooking

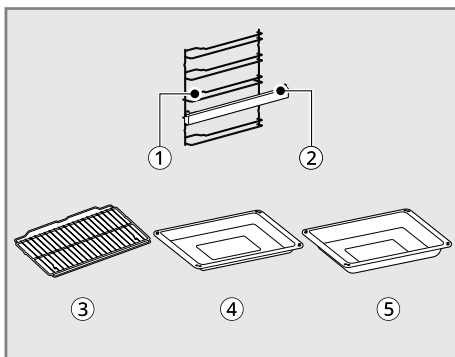

①	Rail Rack (2 ea)
②	Telescopic Runner (2 ea) • WSED7613* model only
③	Wire Grill (1 ea)

④	Baking Tray (1 ea)
⑤	Deep Baking Tray (1 ea) • WSED7613* model only

Accessories for Installation

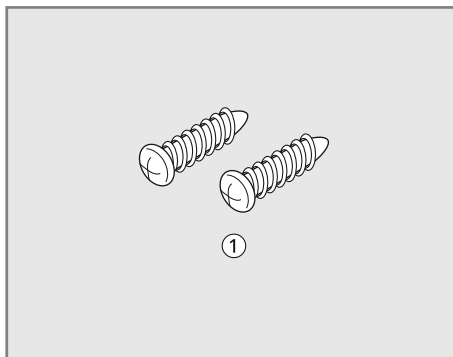

①	Wood Screws for Mounting (2 ea)
---	---------------------------------

Manuals

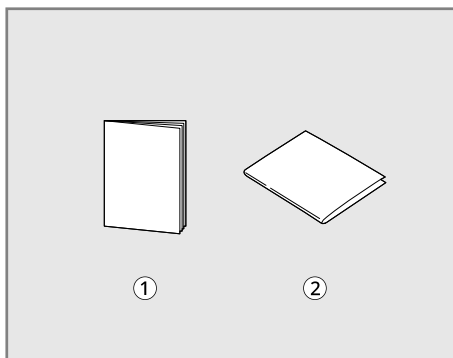

①	Owner's Manual
②	Installation Guide

OPERATION

Operating Control Panel

Control Panel Features

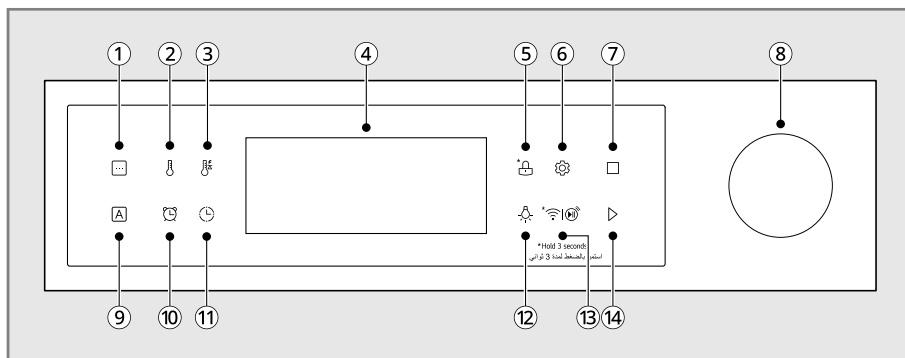























①	Menu Press to select the desired cooking mode.
②	Temperature Press to choose a Temperature .
③	Rapid Preheat Press to use Rapid Preheat function.
④	Display Press any button on the control panel to activate the display.
⑤	Control Lock Press and hold the button for 3 seconds to activate or deactivate Control Lock .
⑥	Settings Press to adjust oven settings.
⑦	Stop Press to stop all active operations on the oven.
⑧	Control Knob Turn the knob to select oven operating mode. See Operating the Oven .
⑨	Recipe Cook Press to use Recipe Cook function. See Operating the Oven .
⑩	Timer Press to set or cancel the timer of the oven.
⑪	Cook Time & End Time Press to use Cook Time & End Time function.

⑫	<p>Light Press to turn the lights of the oven on and off.</p>
⑬	<p>Remote Start Press to select the Remote Start function. Wi-Fi Press and hold the button for 3 seconds to connect the appliance to a Wi-Fi network.</p>
⑭	<p>Start Press to start the selected functions on the oven.</p>

Display Icons

Icons appear in display when activated.

Icon	Meaning	Icon	Meaning
	Economic Mode (Economic Hot Air, Economic Top Bottom Heat)		Temperature
	Pizza Mode		Rapid Preheat
	Air Fry		Timer
	Air Sous-Vide		Cook Time
	Warm		End Time
	Defrost		Lock
	Proof		Sound Setting
	Pyrolysis (WSED7613* model only)		Demo Mode
	EasyClean		Wi-Fi
	InstaView		Remote Start

Icon	Meaning	Icon	Meaning
	Clock Setting		Recipe Cook

Energy Saving Tips

- Multiple-rack cooking saves time and energy. Whenever possible, cook foods requiring the same cooking temperature together in one oven.
- For optimal performance and energy savings, follow the guides for proper rack and pan placement.
- Reduce energy use by cleaning light oven soil with the **EasyClean** feature instead of **Pyrolysis**.
- Avoid opening the oven door more than necessary during use. This helps the oven maintain temperature, prevents unnecessary heat loss, and saves on energy use.

Changing Settings

Settings (InstaView, Clock, Volume)

To adjust settings after the initial setup, press **Settings** button on the control panel to open the settings screen.

Press **Settings** button  repeatedly or turn the control knob to toggle through and change oven settings.

The **Settings** allows you to:

- set InstaView function
- set the hour mode on the clock (12 or 24 hours)
- adjust the volume

Setting InstaView

InstaView function allows you to see the contents of the oven without opening the door by knocking the glass panel.

- 1) Press **Settings** button  once or turn the control knob to select InstaView function. The symbol is flashing.

	InstaView
---	-----------

- 2) Push the control knob to change the setting.
- 3) Turn the control knob to turn InstaView on/off.
- 4) Push the control knob to accept the change.

Setting the Clock

The time shows in the display when the oven is not in use.

- 1) Press **Settings** button  twice or turn the control knob to select the clock. The symbol is flashing.

	Clock Setting
---	---------------

- 2) Push the control knob to change the setting.
- 3) Turn the control knob once to select a 12-hour clock, or twice to select a 24 hour clock, and then push to set.
- 4) Turn the control knob to set the hour and minute.
- 5) Push the control knob to accept the change.

Adjusting the Volume

Adjust the volume of the acoustic signal.

- 1) Press **Settings** button  3 times or turn the control knob to select the volume. The symbol is flashing.

	Sound Setting
---	---------------

- 2) Push the control knob to change the setting.
- 3) Turn the control knob to select **OFF**, **Lo**, or **Hi**.

- 4) Push the control knob to accept the change.

Setting a Cook Mode

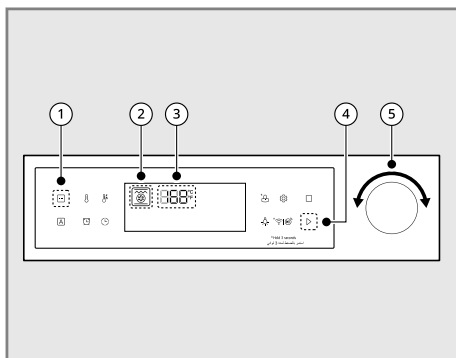



- 1) Press the **Menu** button ① sequentially or turn the control knob ⑤ to select the desired operating mode ②.
- 2) Push the control knob ⑤ to select the desired operating mode ②.
- 3) Turn the control knob ⑤ to select the desired cooking temperature ③.
- 4) Press **Start** button ④ or press the control knob ⑤ to start the operation.

Control Lock

The **Control Lock** feature automatically prevents most oven controls from being turned on. It disables the clock, timer and the interior oven light. It does not lock the oven door.

Lock / Unlock

- 1) Press the **Control Lock** button  for 3 seconds on the display to stop all buttons from operating.
- 2) Press the **Control Lock** button  again for 3 seconds on the display to release all buttons from Control Lock.

NOTE

- **Control Lock** cannot be set during oven operation.

Oven Light

The interior oven light automatically turns on when the door is opened.

- Press **Light** button  to manually turn the oven light on/off.
- When the oven reaches its set-temperature, the preheating light flashes 5 times.
- Knocking twice on the glass panel turns the interior light on or off.

Wi-Fi

Connect the appliance to a home Wi-Fi network to use Remote Start and other smart functions. See the Smart Functions section for more details.

Setting Up Wi-Fi

- 1) Press and hold **Remote Control** button for 3 seconds, the **Remote Control** icon flashes when **Wi-Fi** is ready to use.
- 2) Follow the instructions in the **LG ThinQ** app on your smartphone for using the Wi-Fi function.

Remote Start

If the appliance is registered on a home Wi-Fi network, the preheating function of the oven can be started or stopped using the **LG ThinQ** smartphone app.

Setting Remote Start (network port activation or deactivation)

- 1) Open the oven door to make sure the oven is empty and ready for preheating. Do not place food in the oven.
- 2) Close the oven door. **Remote Start** can only be set when the oven door is closed.

- 3) To activate, Press the **Remote Start** button. the **Remote Start** icon appears when ready to use.
- 4) To deactivate, Press the **Remote Start** button again. the **Remote Start** icon disappears.
- 5) Follow the instructions in the **LG ThinQ** smartphone app for using the **Remote Start** function.

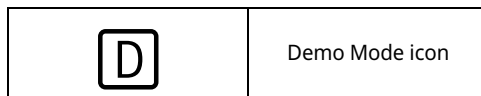

- 3) To deactivate, press the **Recipe Cook** button ① and the **Light** button ② at the same time for 3 seconds.

NOTE

- Remote Start is disconnected in the following situations:
 - Remote Start is never set up in the smartphone app.
 - Remote Start experiences a problem during operation.
- The Wi-Fi icon on the display shows the status of the appliance's network connection. If the Wi-Fi icon is not lit, use the smartphone app to select the Wi-Fi network or register the product again.
- A faulty Wi-Fi connection could delay the Remote Start function.

Operating the Oven

Before Using the Oven

NOTE

- Because the oven temperature cycles, an oven thermometer placed in the oven cavity may not show the same temperature that is set on the oven.
- The heating turns off if the door is open during operating. The heat turns back on automatically once the door is closed.
- Avoid opening the oven door more than necessary during use. This helps the oven maintain temperature, prevents unnecessary heat loss, and saves on energy use.

Demo Mode

Demo Mode is for showroom or store use only. The oven will not heat up when Demo Mode is activated.

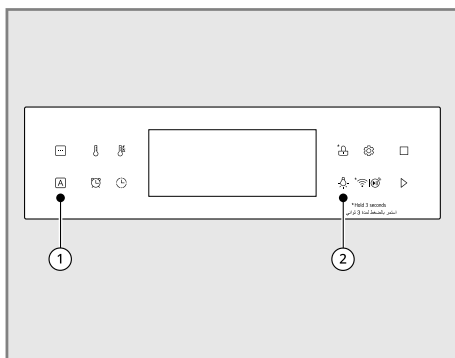

- 1) Press the **Recipe Cook** button ① and the **Light** button ② at the same time for 3 seconds.
- 2) Demo Mode icon appears in the display when activated.

Getting Start

After connecting the appliance to the power or following a power cut, the colon in times flashing. To clear the flashing time, press any button and reset the clock if needed.

Cleaning the cooking compartment and accessories

Before using the appliance to prepare food for the first time, you must clean the cooking compartment and accessories.

Clean the accessories by hand as is described in the **Maintenance** instructions.

- Ventilate the kitchen while the appliance is heating up.
- Make sure there are no remaining packing materials such as polystyrene pellets in the cooking chamber and remove any adhesive tape from inside or outside the appliance.

24 OPERATION

Refer to **Manual Cook** for how to operate the oven.

- Wipe the smooth surface of the cooking chamber with a soft, damp cloth before heating the appliance.
- To get rid of the smell of new products, heat them with the oven door closed when the cooking chamber is empty.

Oven Vent

Areas near the vent may become hot during operation and may cause burns. Avoid placing plastics near the vent as heat may distort or melt the plastic.

It is normal for steam to be visible when cooking foods with high moisture content.

⚠ WARNING

- Do not block the vent between the oven door and the controller.

Assembling Rail (Telescopic) Rack

Assemble the rail racks on both sides of the oven cavity before operating the oven for the first time. This keeps cookware in position.

⚠ WARNING

- Remove the protection film from all telescopic runners.

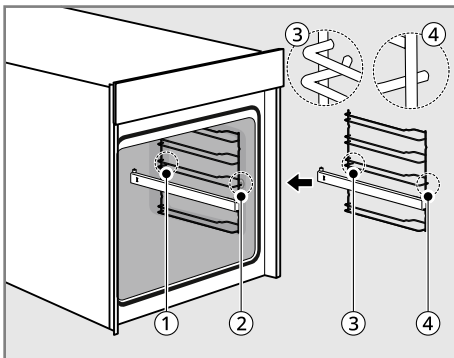

①	Rear Hole
②	Front Hole
③	Rear Rail Rack Hook (curved)
④	Front Rail Rack Hook (straight)

- 1) Align the rack inside the oven cavity. So that the curvature of the rack is pointing to the oven door.
 - The pins of the telescopic runners must be pointed upwards.
- 2) Insert the rear rail rack hook ③ into the oven cavity hole ①.
- 3) Insert the front rail rack hook ④ into the oven cavity hole ② and press down to secure the fitting.
- 4) Repeat steps 1-3 for the other side of the oven cavity.

Removing Rail Rack

⚠ WARNING

- Do not touch the oven racks while they are hot.

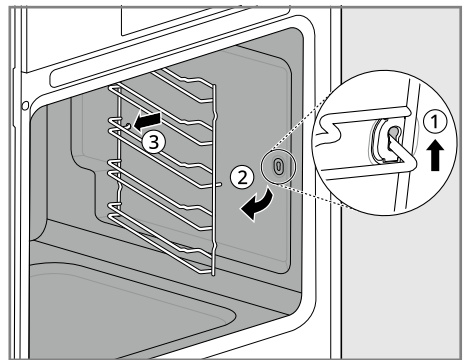

- 1) Lift up the rack slightly ①.
- 2) Pull the front of the rack away from the side wall ②.
- 3) Continue to Swing the front of the rack to the center of the oven ② while pulling the rear of

the rack away from the side wall to release its hook ③.

- 4) Repeat steps 1-3 for the other side of the oven cavity.

Using the Telescopic Runners

The telescopic runners slide in and out on a frame. This keeps heavy cookware level and prevents it from sliding forward when the telescopic runner is completely extended.

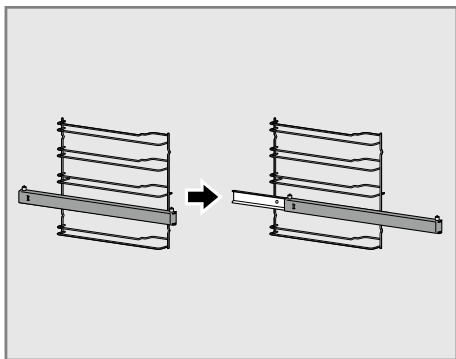

- Make sure to slide the tray and wire grill in a correct position as the telescopic runner pins are inserted through the holes on both sides.

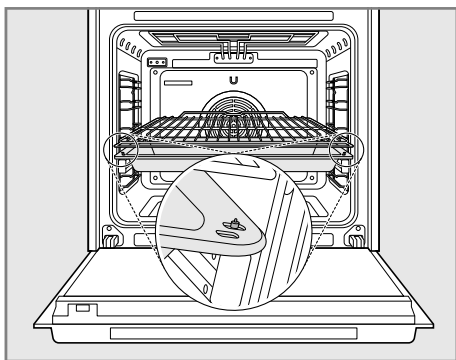

Using Standard Oven Racks

The racks have a turned-up back edge that prevents them from being accidentally pulled out of the oven cavity.

⚠ CAUTION

- Replace oven racks before turning the oven on to prevent burns.
- Do not cover the racks with aluminum foil, or any other material, or place anything on the bottom of the oven. Doing so will result in poor baking and may damage the oven bottom.
- Only arrange oven racks when the oven is cool.

Removing Racks

- 1) Pull the rack straight out until it stops.
- 2) Lift up the front of the rack and pull it out.

Replacing Racks

- 1) Place the end of the rack on the support.
- 2) Tilt the front end up and push the rack in.

InstaView

Knock twice on the center of the glass panel to reveal the contents of the oven without opening the door.

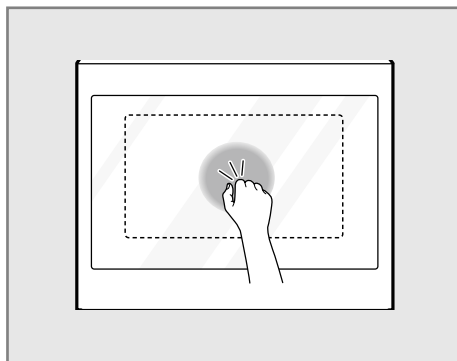

⚠ CAUTION

- Do not hit the glass door panel with excessive force. Do not allow hard objects like cookware or glass bottles to hit the glass door panel. The glass could break, resulting in a risk of personal injury.

NOTE

- Knocking twice on the glass panel turns the interior light on or off.
 - The light stays ON during cooking.
 - The light turns off automatically after 5 minutes and switches to standby mode when cooking is finished or the oven is not in operation.
 - The InstaView function is disabled when the oven door or oven controller is opened and for one second after closing the door.
 - The InstaView function is disabled during **Pyrolysis**, **Control Lock** Mode and initial power input (on some models only).
 - Tapping the edges of the glass panel may not activate the InstaView function.
 - The taps on the glass panel must be hard enough to be audible.
 - The taps on the control panel or loud noises near the oven may activate the InstaView function.
-

Manual Cook

Setting the Manual Cook

CAUTION

- Pressing the **Stop** button during cooking clears all settings.
-

NOTE

- If the cook time is not set, it cooks for the maximum default cook time for the selected cook mode.
- 1) Turn the control knob or press the **Menu** button sequentially to select the desired cook mode, and then push the control knob to set.
 - 2) Turn the control knob to select the desired temperature.
 - 3) If desired, press the **Rapid Preheat** button to use the rapid preheat feature. The Rapid Preheat icon  appears in the display.

- 4) If desired, press the **Cook Time** button to select the desired cooking time and end time.
- 5) Press the **Start** button or control knob.
- 6) Press the **Stop** button to cancel at any time or when cooking is complete.

Setting the Rapid Preheat Mode

This function is designed for quick preheating of the cooking chamber.

NOTE

- **Rapid Preheat** is available in cook mode **Hot Air**, **Top Bottom Heat** and **Fan Assisted Air**.
 - Always switch off **Rapid Preheat** when baking on more than one oven rack.
 - To switch off the Rapid Heat function press the **Rapid Preheat** button again.
-

- 1) Turn the control knob or press the **Menu** button sequentially to select the desired cook mode, and then push the control knob to set.
- 2) Turn the control knob to select the desired temperature.
- 3) Press the **Rapid Preheat** button to use the rapid preheat feature. The Rapid Preheat icon  appears in the display.
- 4) If desired, press the **Cook Time** button to select the desired cooking time and end time.
- 5) Press the **Start** button or control knob.
- 6) Press the **Stop** button to cancel at any time or when cooking is complete.

Changing the Oven Temperature

- 1) Press the **Temperature** button. The adjusted temperature is flashing.
- 2) Adjust the oven temperature using the control knob.
- 3) Press the **Start** button or control knob.

Changing the Cook Time

- 1) Press the **Cook Time** button. The corresponding symbol is flashing in the display.

	Cook Time
---	-----------

- 2) If desired, turn the knob to select the desired hour.
- 3) Press knob to save the hour and enter minute setting.
- 4) Turn the knob to select the desired minute.
- 5) Press the **Start** button or control knob.

Changing the End Time

- 1) Press the **Cook Time** button 2 times. The corresponding symbol is flashing in the display.

	End Time
---	----------

- 2) Adjust the end time using the control knob.
- 3) Press the **Start** button or control knob.







NOTE







- When the oven is in process you can change the cooking time and end time.

To Stop Cooking



- 1) Press the **Stop** button.

Manual Cook Guide

Cook Mode		Temp. Range (Default) °C	Description
Hot Air ^{*1*2}		30-275 (160)	Hot Air mode uses only the heating element in the back wall and the convection fan. The recommended temperature is 160 °C. It is also possible to bake on more than one rack in Hot Air mode. This means that it is suitable for fruit cakes and stirred cake or yeast-dough, for example, a bread plait.
Economic Hot Air ^{*1}		30-275 (160)	Economic Hot Air mode uses the optimised heating system to save energy while cooking food. The recommended temperature is 160 °C. In this mode, residual heat can be used to conserve energy. To avoid losing heat, always keep the door closed when cooking.
Top Bottom Heat ^{*1*2}		30-300 (170)	In Top Bottom Heat mode, the upper and concealed lower heating elements are used. This operating mode is suitable for baking cakes, baking for a short time, and sensitive doughs. The recommended temperature is 170 °C.
Roasting ^{*1}		30-300 (190)	In Roasting mode, the upper heating element and the convection fan are on. The recommended temperature is 190 °C. This function is suitable for large pieces of meat or poultry, such as rolled roast or turkey.
Pizza Mode ^{*1}		30-300 (180)	In Pizza mode, the concealed heating element at the bottom of the oven cavity and the element in the back wall and convection fan are activated. The recommended temperature is 180 °C. When using pizza mode, the cooking time must vary depending on the type and thickness of the dough and topping.
Fan Assisted Air ^{*1*2}		30-300 (160)	In addition to the Top Bottom (upper and concealed lower) heating elements, Fan Assisted Air mode uses the convection fan. This means that the roasting and baking temperature can be reduced by 20-40 °C. The recommended temperature is 160 °C. This mode is suitable for cakes and biscuits, as it is possible to bake on more than one rack at the same time.

Cook Mode		Temp. Range (Default) °C	Description
Large Grill		L3 (High, Default) / L2 (Medium) / L1 (Low)	Large Grill mode uses the entire grill heating element. No specific temperature can be set. You can choose between three settings. The Large grill is suitable for cooking steaks, cutlets, fish or making toast, and for browning when cooking larger dishes with a gratin topping. The preset level is high. Always grill with the door closed.
Small Grill		L3 (High, Default) / L2 (Medium) / L1 (Low)	Small Grill mode operates in the same way as the Large grill, however, only part of the grill heating element is used. This makes it suitable for smaller dishes. The preset level is High. Always grill with the door closed.
Bottom Heat* ¹		30 - 250 (170)	In Bottom Heat mode, only the concealed heating element in the oven floor is used. The recommended temperature is 170°C. This function is particularly suitable for finishing off cakes or pizzas on one of the lower oven rack positions.
Economic Top Bottom Heat* ¹		30 - 300 (170)	Economic Top Bottom Heat mode uses the optimised heating system to save energy while cooking food. The recommended temperature is 170 °C. In this mode, residual heat can be used to conserve energy. To avoid losing heat, always keep the door closed when cooking.
Air Fry		150 - 275 (200)	The Air Fry function is specially designed for oil free frying.
Air Sous-Vide		30 - 100 (50)	Air Sous-Vide mode uses air to cook foods "low and slow." Use it to cook meat, fish, seafood, poultry or vegetables. Food must be vacuum packed in pouches before cooking
Warm		40 - 100 (75)	In Warm mode, the heating element at the top and concealed element at the bottom of the oven cavity are activated. You can use this function for keeping food warm until ready to serve. In this mode, a selectable temperature from 40 °C to 100 °C can be set. The duration of this function can also be set.

30 OPERATION

Cook Mode		Temp. Range (Default) °C	Description
Defrost		-	In Defrost mode, only the fan is used without heating. The circulating air speeds up the defrosting process. Place the frozen food in a suitable container to trap the liquid produced during defrosting. Where appropriate, you can use the wire grill and a deep pan (or baking tray) to avoid soiling the oven. If water is allowed to run out into the oven, the door seal will be contaminated and an unpleasant odour may result.
Proof		30 - 60 (40)	Proof mode maintains a warm oven for rising yeast leavened products before baking. To avoid lowering the oven temperature and lengthening proofing time, do not open the oven door unnecessarily. Check bread products early to avoid over proofing. Do not use the proofing mode for warming food or keeping food hot. The proofing oven temperature is not hot enough to keep foods at safe temperatures. Use the Warm feature to keep food warm.

*1 Once the oven reaches the set temperature, a tone sounds and light flashes 5 times.

*2 This function can be used with the Rapid Preheat.

Baking

When baking, use the Hot Air or Top Bottom Heat modes.

Baking Tins

- When baking in Top Bottom Heat modes, use baking tins with a dark metal or coated surface.
- When baking with Hot Air, you can also use baking tins with a bright metal surface.
- Always place cake tins in the middle of the tray or wire grill.
- When baking with Top Bottom Heat, you can place two baking tins side by side in the oven. This means that the baking time is only slightly longer.

Oven Rack Position

The Oven Rack Positions are numbered from the bottom up.

When using Top Bottom Heat, you can bake on one rack only, for example on rack position ③.

When using Hot Air, you can bake sponge bases and biscuits on up to two baking trays at the same time, for example on rack position ② and ④.

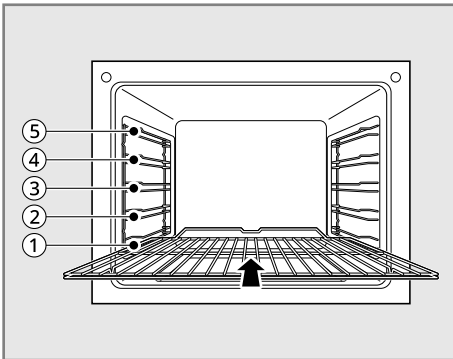

Recommended Baking Guide

The baking guide contains the temperature settings, baking times and oven rack positions for a selection of typical dishes.

- Temperatures and baking times should be regarded as reference figures only. The actual values depend on the type of preparation, quality of ingredients and the baking tin in use.
- We recommend first selecting a lower temperature and then increasing it if necessary, for example if you want a higher degree of browning or the baking time is too long.
- If you cannot work out the settings for a specific recipe, simply use the settings for the most similar recipe.
- When baking cakes on baking trays or in tins on more than one rack, the baking time may be extended by 10-15 minutes.
- Foods with a high liquidity content (e.g. pizza, fruit cakes, etc.) should be baked on a single rack only.
- With cakes and baked items with different racks of dough, uneven browning may take place initially. In this case, do not alter the temperature setting. The degree of browning will even itself out over the baking process.
- For energy saving, use the residual heat for 8 minutes before you finish cooking.

NOTE

- Always count Rack Position from the bottom up.



*1 Preheat the oven.



*2 Always switch off "Rapid Preheat" when baking on more than one oven rack.



*3 Use deep pan (or baking tray).

Baking on a single oven rack



- Rack: Rack Position

Cakes in baking tins					
Cook Mode	Hot Air 		Top Bottom Heat 		Time (minute)
	Category	Rack	Temp. (°C)	Rack	
Ring-shaped pound cake	2	150-160	2	160-180	50-70
Biscuits / pancakes	2	140-160	2	150-170	30-60
Sponge finger	2	150-160	2	160-180	25-40
Flan base - shortcrust pastry	3	170-180	2	190-210 *1	10-25
Flan base - cake mixture	3	150-170	2	170-190	20-25

Cakes in baking tins					
Cook Mode	Hot Air 		Top Bottom Heat 		Time (minute)
	Category	Rack	Temp. (°C)	Rack	
Apple pie	3	160-180	1	170-190	65-75
Spicy cakes and flan base (e.g. quiche lorraine)	2	160-180	2	190-210	30-70
Cheesecake	2	140-160	2	170-190	60-90

Cakes on baking tray					
Cook Mode	Hot Air 		Top Bottom Heat 		Time (minute)
	Category	Rack	Temp. (°C)	Rack	
Bread plaits / larger cakes	3	160-170	4	170-190	30-40
Christmas stollen	3	150-170 *1	4	160-180 *1	40-60
Bread (rye bread) Fermentation is required	2	180-200 *1 140-160	2	230 *1 160-180	20 30-60
Pie / eclair	3	160-170 *1	4	190-210	15-30
Swiss roll	3	150-170 *1	4	180-200 *1	10-20
Fruit cake with shortcrust pastry	3	160-170 *1	4	170-190 *1	40-80
Slices with topping / filling e.g. quark, cream, sugar, almonds	-	-	4	160-180 *1	40-80
Pizza (thick base) *2*3	1	180-200	1	190-210 *1	30-60
Pizza (thin base) *2	1	200-220	1	230 *1	10-25
Unleavened bread	1	200-220	1	230 *1	08-15
Swiss flan	1	180-200	1	210-230	35-50

34 OPERATION

Biscuits					
Cook Mode	Hot Air 		Top Bottom Heat 		Time (minute)
	Rack	Temp. (°C)	Rack	Temp. (°C)	
Shortcrust biscuits *2	3	150-160	4	170-190 *1	06-20
Iced biscuits *2	3	140-150	4	160-180	10-40
Cake mixture biscuits *2	3	150-160	4	170-190	15-20
Cakes and pastries with egg white, meringues	3	80-100	4	100-120	120-150
Macaroons	3	100-120	4	120-140	30-60
Yeast dough biscuits *2	3	160-170	4	170-190	20-40
Puff pastry cakes and pastries	3	160-180 *1	4	190-210 *1	20-30
Bread rolls	3	180-200 *1	4	180-220 *1	20-35

Baking on more than one oven rack

- Rack: Rack Position

Cakes /cakes and pastries on baking sheet			
Category	Hot Air 		Time (minute)
	Rack	Temp. (°C)	
Pie / eclair *2	2, 4	160-180 *1	35-60
Dry sponge cake with crumble topping *2	2, 4	140-160	30-60
Shortcrust biscuits *2	2, 4	150-160	15-35
Iced biscuits *2	2, 4	140-150	20-60
Cake mixture biscuits *2	2, 4	160-170	25-40
Cakes and pastries with egg white, meringues *2	2, 4	80-100	130-170
Macaroons *2	2, 4	100-120	40-80

Cakes /cakes and pastries on baking sheet			
Category	Hot Air 		Time (minute)
	Rack	Temp. (°C)	
Yeast dough biscuits *2	2, 4	160-170	30-60
Puff pastry cakes and pastries *2	2, 4	170-180 *1	30-50
Bread rolls *2	2, 4	180-190 *1	30-55

NOTE

- This is optional for products with two trays.
- Place the deep pan (or baking tray) on rack position ①.

Guide for strudel and baked dishes

- Rack: Rack Position

Category	Top Bottom Heat 		Time (minute)
	Rack	Temp. (°C)	
Baked pasta	1	180-200	45-60
Lasagne	1	180-200	30-60
Baked vegetables	1	200-220 *1	15-30
Pizza baguette	1	200-220 *1	15-30
Soufflé	1	180-200	20-50
Fish pie	1	180-200	30-60
Stuffed vegetables	1	180-200	30-60

Guide for frozen ready-made dishes

- Rack: Rack Position

Category	Top Bottom Heat		Time (minute)
	Rack	Temp. (°C)	
Frozen pizza	3	Follow instructions on pack.	Follow instructions on pack.
Baguettes	3	Follow instructions on pack.	Follow instructions on pack.
Fruit cake base	3	Follow instructions on pack.	Follow instructions on pack.
Chips	3	200-220	15-25

NOTE

- Turn chips 2 or 3 times when heating.
- When heating frozen dishes, the baking tray may bend out of shape because of the great difference in the temperature of the frozen food and the oven. Trays normally return to their original shape once they have cooled down.

Tips for baking

Results of Baking	Possible Cause	Solution
The cake base is too light	Wrong oven rack position	Use a dark baking tin or put the cake one rack lower down.
Cake collapses (turns lumpy, soggy)	Oven temperature too high	Set the temperature slightly lower.
	Baking time too short	Set a longer baking time. The baking time cannot be reduced by setting a higher temperature.
	Mixture contains too much liquid	Use less liquid. Follow instructions for dough mixing times, especially when using kitchen appliances.
Cakes are too dry	Oven temperature too low	Next time set a slightly higher temperature.
	Baking time too long	Set a slightly shorter baking time.

Results of Baking	Possible Cause	Solution
Cakes are browned unevenly	Baking temperature too high and baking time too short	Set a slightly lower baking temperature and a slightly higher baking time.
	Mixture unevenly distributed	Distribute the mixture evenly over the baking tray/tin.
Baking time too long	Temperature too low	Next time set a slightly higher temperature.

Hot Air / Economic Hot Air

NOTE

- If no cook time is set, the oven turns off automatically after 12 hours.
- The oven fan runs during the **Hot Air** cycle. The fan stops when the door is open. In some cases, the fan may shut off during the **Hot Air** cycle.

- Use dark black enameled tins that absorb heat particularly well.
- Remove unused accessories from the oven.

Tips for Hot Air

- Use Hot Air for faster and more even multiple-rack cooking of pastries, cookies, muffins, biscuits, and breads of all kinds.
- Bake cookies and biscuits on pans with no sides or very low sides to allow heated air to circulate around the food. Food baked on pans with a dark finish will cook faster.
- When using Hot Air with a single rack, place the wire grill in position ③. If cooking on multiple racks, place the wire grill in positions ② and ④ (for two racks).
- Multiple oven rack cooking may slightly increase cook times for some foods.
- Cakes, cookies and muffins have better results when using multiple racks.

Tips for Economic Hot Air

- When possible, do not preheat the oven before placing food inside.
- Only preheat if it is specified in the recipe.
- To maximize energy efficiency, do not open the door during cooking.

Recommended Economic Hot Air Guide

This table is intended as a guide only, individual tastes and cuts of meat will vary.

Always count the oven rack position from the bottom up.

The durations given are for an oven which has not been pre-heated.

- Rack: Rack Position

Food		Rack	Temp. (°C)	Time (minute)
In a baking tin	Flan base - cake mixture	3	150-170	35-45
	Spicy cakes and flan base (e.g. quiche lorraine)	2	160-180	30-70
On a baking tray	Pizza (thin base)	1	200-220	15-30
	Meringue	3	80	120-150
Biscuits	Iced	3	140-150	10-40
	Cake mixture	3	150-160	25-35
Meat	Beef (approx. 1 kg)	2	190	60-80
	Poultry (approx. 1 kg)	2	210	50-70
	Poultry (approx. 2 kg)	2	210	60-80

Grilling

For grilling, you have a choice of 2 different operating modes.

- For larger quantities of flat food for grilling, for top-baking in large tins. Choose power levels (L3 High, L2 Medium, L1 Low), as suitable for the food being grilled.
- For smaller quantities of flat food for grilling, for top-baking in small tins. Choose 1 of 3 power levels (L3 High, L2 Medium, L1 Low), as suitable for the food being grilled.

WARNING

- Exposed parts of the oven can become hot during grilling. Keep children at a distance.

NOTE

- Close the door to set the Grill function. If the door is open, the grill function cannot be set and door appears in the display. If the door is opened during grilling, the grill heater turns off. Once the door is closed, the grill heater turns back on automatically.

Tips for Reducing Smoke

Due to the intense heat associated with grilling, it is normal to experience smoke during the cooking process. This smoke is a natural by product of searing and should not cause you to worry. If you are experiencing more smoke than you are comfortable with, use the following tips to reduce the amount of smoke in your oven.

- The wire grill should always be thoroughly cleaned and at room temperature at the beginning of cooking.

- ALWAYS run your cooktop ventilation system or vent hood during grilling to help expel smoke from the room.
- Keep the interior of your oven as clean as possible. Leftover debris from prior meals can burn or catch fire.
- Avoid fatty marinades and sugary glazes. Both of these will increase the amount of smoke you experience. If you would like to use a glaze, apply it at the very end of cooking.
- If you are experiencing significant smoke with any food item, consider:
 - Lowering the griller to the **L1** setting.
 - Lowering the rack position to cook the food farther away from the grill heater.
 - Using the **L3** grill setting to achieve the level of searing you desire, and then either switch to the **L1** grill setting, or to the Top Bottom Heat mode.
- As a rule, fatter cuts of meat and fish will produce more smoke than leaner items.
- Adhere to the recommended grill settings and cooking guidelines in the chart on the following page whenever possible.

Recommended Grilling Guide

The grilling times are intended as approximate values only. The actual times may vary depending on the quality of the actual meat or fish. Grilling is particularly suitable for cooking flat pieces of meat and fish. Turn the grilled food over about half way through the cooking time.

Always count oven rack position from the bottom up.

*1 Wire grill or deep pan or baking tray.

Food	Rack Position	Large Grill Step 3 (minute)	
		1st Side	2nd Side
Rissoles	5	8-10	6-8
Beef or Veal Steaks	4	8-12	5-10
Beef Fillet (1 kg approx.)	4	10-12	10-12
Toast *1	4	2-4	2-4
Toast with topping	4	6-8	-

NOTE

- Use rack position ④ or ⑤ for grilling flat pieces of meat.
- Place a deep pan or baking tray below the wire grill to catch drippings or fat falling from food.

Defrosting

Use the Defrost  operating mode to defrost food.

Defrosting Dishes

- Remove the dish from its packaging, put it on a plate and place the plate on the wire grill.
- Do not cover the dish with a plate or bowl, as this can considerably extend the defrosting time.

- Do not use the liquid produced during defrosting for cooking the dish to avoid the risk of salmonella. Ensure that the liquid produced during defrosting is free to run off the food onto the plate or a baking pan if using the wire grill.

Oven Rack Position

For defrosting, use the wire grill on rack position ① or ② for larger dishes.

Recommended Defrosting Guide

Food	Weight (kg)	Time (minute)	Instructions
Chicken	1.0	100-140	Use the wire grille with the deep pan (or baking tray). Turn the chicken after half of the time.
Meat	1.0	100-140	Turn the meat after half of the time or cover with tin foil.
	0.5	90-120	
Trout	0.15	25-35	Do not cover.
Strawberries	0.3	20-30	Do not cover.

Roasting

When roasting, use the Roasting and Top Bottom Heat modes.

The roasting guide contains the required temperatures, roasting times and oven rack positions for various kinds of meat. The figures stated are approximate figures only.

- We recommend cooking meat and fish weighing over 1 kg in the oven.
- For lean meat and fish, use Top Bottom Heat. For all other kinds of meat we recommend Roasting mode.
- Add a little liquid to prevent roasting juices or fat from getting burned onto the pan surfaces.
- Turn the food over after about half or two thirds of the cooking time.

NOTE

- This roasting guide is intended as a guide only, individual tastes and cuts of meat will vary.

WARNING

- Allow the oven to cool down enough to ensure there is no risk of burning yourself.

Recommended Roasting Guide

Food	Rack Position	Roasting		Top Bottom Heat	
		Temp. (°C) *1	Time (minute)	Temp. (°C) *1	Time (minute)
Beef (approx. 1 kg)	2	190	50-70	200	70-90
Venison (approx. 1 kg)	2	180	75-100	200-230	100-120
Leg of lamb (approx. 1 kg)	2	180	110-130	200	150
Poultry (approx. 1 kg)	2	210	50-60	200-220	70-90
Poultry (approx. 2 kg)	2	200	60-80	200-220	110-120
Poultry (approx. 4 kg)	2	180-190	120-140	190-210	130-150
Whole fish (approx. 1.5 kg)	2	160-180	35-55	200-220	35-55
Roast chicken	4	190	55-65	-	-

*1 Set the pot roasting temperature 20 °C higher.

Tips for Roasting

- For better roasting results, baste joints and poultry with their own juices a number of times during the roasting process.
- Use heat resistant dishes when roasting (follow manufacturer's instructions).
- Stainless steel roasting pans are only of limited use, as they reflect the heat to a very large extent.
- When using dishes with plastic handles, ensure that the handles are heat resistant (follow manufacturer's instructions).
- Large items for roasting or a number of items can be placed directly on the wire grill above the deep pan (or baking tray) (e.g. turkey, goose, 3~4 chickens, 3~4 knuckles of veal).
- Lean meat should be roasted in a roasting tray with a lid (e.g. veal, braised beef, deep frozen meat). This keeps the juices in the meat.
- Pour enough water into the deep pan (or baking tray) to prevent smoke generation when you use roasting mode.
- Clean the oven as soon as possible after use if you are roasting in an open-topped tin or dish. It

is easier to remove fat splashes when the oven is still warm.

Recipe Cook Mode

The Recipe Cook function provides guidance for cooking foods or dishes that may be unfamiliar. It contains preset programs for cooking many popular food items, with information on recommended preheating, accessories, and rack position for optimal results.

Setting Recipe Cook Mode

- 1) Press the **Recipe Cook** button on the control panel.

- 2) Press the **Recipe Cook** button again or turn the control knob to select the desired recipe, and then push the control knob to set.
 - See the Recipe Cook Guide for more details.
- 3) Press **Start** or the control knob to start cooking.
- 4) Press the **Stop** button on the control panel to cancel at any time or when cooking is complete.

Recipe Cook Guide

Poultry					
No	Menu	Weight Limit	Food Temp.	Rack Position	Instructions
1	Chicken, Legs *1*2	1.2 kg	Refrigerated	3	Brush chicken legs with oil or melted butter, season as desired. Place chicken legs on the wire grill. Put into the oven. To catch drippings or fat from food, place the deep pan (or baking tray) below of the wire grill. When oven beeps, turn food over. After cooking, allow to rest covered with foil for 3 minutes. Use generated juice for gravy or sauce.
2	Chicken, Whole *1*2	1.4 kg	Refrigerated	2	Brush chicken with oil or melted butter, season as desired. Wrap thin part of the legs in foil, place chicken on the wire grill. Put into the oven. To catch drippings or fat from food, fill a big cup of water into the deep pan (or baking tray) and place below of the wire grill. When oven beeps, turn food over. After cooking, allow to rest covered with foil for 3 minutes. Use generated juice for gravy or sauce.
3	Duck, Whole *1*2	2.1 kg	Refrigerated	2	Brush duck with oil or melted butter, season as desired. Wrap thin part of the legs in foil, place duck on the wire grill. Put into the oven. To catch drippings or fat from food, fill a big cup of water into the deep pan (or baking tray) and place below of the wire grill. When oven beeps, turn food over. After cooking, allow to rest covered with foil for 3 minutes. Use generated juice for gravy or sauce.

44 OPERATION

Poultry					
No	Menu	Weight Limit	Food Temp.	Rack Position	Instructions
4	Turkey, Whole *1*2	4.2 kg	Refrigerated	1	Brush turkey with oil or melted butter, season as desired. Wrap thin part of the legs in foil, place turkey on the wire grill. Put into the oven. To catch drippings or fat from food, fill a big cup of water into the deep pan (or baking tray) and place below of the wire grill. When oven beeps, turn food over. After cooking, allow to rest covered with foil for 3 minutes. Use generated juice for gravy or sauce.

Beef					
No	Menu	Weight Limit	Food Temp.	Rack Position	Instructions
5	Kebab *2	1.5 Kg	room	4	<p>Ingredients 1.2 kg ground meat (Mix beef and veal at a ratio of 3 to 1), 2 eggs, ½ tsp minced garlic, 1 small onion chopped, ½ cup breadcrumbs, 1 tbsp. salt, ½ tsp pepper, ¼ cup finely chopped fresh mint, ¼ cup olive oil</p> <p>Method Combine the ground meat, eggs, garlic onion, breadcrumbs, salt, pepper, mint, and olive oil into a large bowl and mix the ingredients. Roll into balls of 50 g each and pierce each ball through with bamboo skewers and spread into long kebabs, about 3 inch or longer on the skewer. Position the skewers onto a wire grill. Put into the oven and place the deep pan(or baking tray) below of the wire grill. After cooking, let cool kebabs before serving.</p>

Beef					
No	Menu	Weight Limit	Food Temp.	Rack Position	Instructions
6	Kafta *2	1.2 Kg	room	4	<p>Ingredients 1 kg ground beef with some fat(15 %), 1 ½ tsp ground cardamom, 2 ½ tsp ground allspice, 2 tsp salt, 1 tsp black pepper, 1 packed cup (25 g) chopped parsley, 2-3 hot green chile peppers, 4-5 cloves garlic, 1 medium onion</p> <p>Method Place the ground meat in a large bowl and add the spices. Run the parsley, chiles, garlic and onion together through a meat grinder or pulse them gently, adding one ingredient at a time, in a food processor, beginning with the parsley and ending with the onions. Combine with the ground meat. Mould a small quantity of the meat mixture around skewers, forming elongated, thin kebabs. Position the skewers onto a wire grill. Put into the oven and place the deep pan(or baking tray) below of the wire grill.</p>
7	Goulash *3*8	1 serving	room	3	<p>Ingredients 1 tbsp. olive oil, 1 small onion, 680 g lean ground beef, 1 tsp allspice, ½ tsp ground black pepper, 1 tsp salt, ¼ tsp ground cinnamon, ¼ tsp ground ginger, 1 tbsp. tomato paste A packet (45 g) phyllo dough thawed, ½ cup light tasting olive oil, ¼ cup ghee or butter melted, 1 cup milk, 1 large egg, salt and pepper</p> <p>Method Add the olive oil in a large non-stick saute pan and heat, then saute onion for 2-3 minutes until tender. Add the ground beef, breaking it apart then add all the other ingredients. Cook until browned, set aside. Melt ghee in a small sauce pan or in the microwave. Mix in olive oil. Brush or spray an oven safe dish with the oil, take 2-3 sheets of phyllo dough and lay them flat on dish, then brush with oil mixture. Continue layering the phyllo dough 2-3 sheets at a time and brushing them until done with half the package. Add the minced meat mixture and spread evenly. Continue layering and brushing the remaining phyllo sheets until done with the package. Cut into squares or diamond shape. In a measuring cup, beat the egg and add the milk, sprinkle some salt and pepper, then carefully pour into the dish, tilt the dish in all directions so the milk mixture will spread evenly. Put into the oven.</p>

Beef					
No	Menu	Weight Limit	Food Temp.	Rack Position	Instructions
8	Roast beef *1*2	1.5 kg	Refrigerated	2	Brush beef with oil or melted butter, season as desired. Place beef on the wire grill. Put into the oven. To catch drippings or fat from food, fill a big cup of water into the deep pan (or baking tray) and place below of the wire grill. When oven beeps, turn food over. After cooking, allow to rest covered with foil for 10 minutes. Use generated juice for gravy or sauce.
9	Roast veal *1*2	1.5 kg	Refrigerated	2	Brush veal (back of veal) with oil or melted butter, season as desired. Place veal on the wire grill. Put into the oven. To catch drippings or fat from food, fill a big cup of water into the deep pan (or baking tray) and place below of the wire grill. When oven beeps, turn food over. After cooking, allow to rest covered with foil for 10 minutes. Use generated juice for gravy or sauce.
10	Fillet of beef *1*2	0.8 kg	Refrigerated	4	Brush fillet of beef with oil or melted butter, season as desired. Place beef on the wire grill. Put into the oven. To catch drippings or fat from food, place the deep pan (or baking tray) below of the wire grill. When oven beeps, turn food over. After cooking, allow to rest covered with foil for 5 minutes. Use generated juice for gravy or sauce.
11	Beef bourguignon *3*4*8	1 serving	Room	2	<p>Ingredients 1 kg beef, 50 g oil, 750 ml red wine, 200-300 ml broth, 5 onions, 5 cloves of garlic, 200 g mushrooms, 100 g tomato puree, 1 tsp sweet paprika, 5 bay leaves, salt, pepper</p> <p>Method Cut the beef into 1 cm cubes. Put the oil in a roasting pot, add the meat and roast it on a hob. Deglaze the roasted meat with red wine and broth. Peel and dice the onions and garlic. Clean the mushrooms and slice. Add the ingredients, season and mix it, cover with a lid. Place roasting pot on the wire grill. Put into the oven. After cooking, allow to rest covered with foil for 10 minutes.</p>

Lamb					
No	Menu	Weight Limit	Food Temp.	Rack Position	Instructions
12	Leg of lamb *1*2	1.5 kg	Refrigerated	2	Brush leg of lamb with oil or melted butter, season as desired. Place lamb on the wire grill. Put into the oven. To catch drippings or fat from food, fill a big cup of water into the deep pan (or baking tray) and place below of the wire grill. When oven beeps, turn food over. After cooking, allow to rest covered with foil for 10 minutes. Use generated juice for gravy or sauce.
13	Lamb chops *1*2	0.8 kg	Refrigerated	4	Brush lamb chops with oil or melted butter, season as desired. Place lamb chops on the wire grill. Put into the oven. To catch drippings or fat from food, place the deep pan (or baking tray) below of the wire grill. When oven beeps, turn food over. After cooking, allow to rest covered with foil for 3 minutes. Use generated juice for gravy or sauce.

Fish					
No	Menu	Weight Limit	Food Temp.	Rack Position	Instructions
14	Salmon *1*2	0.8 kg	Refrigerated	4	Choose salmon steaks of 200 g weight and 2.5 cm thickness each. Brush salmon with oil or melted butter, season as desired. Place salmon on the wire grill. Put into the oven. To catch drippings or fat from food, place the deep pan (or baking tray) below of the wire grill. When oven beeps, turn food over. After cooking, allow to rest covered with foil for 3 minutes. Use generated juice for gravy or sauce.
15	Trout *1*2	0.8 kg	Refrigerated	4	Choose trout of 200 g weight each. Brush trout with oil or melted butter, season as desired. Place trout on the wire grill. Put into the oven. To catch drippings or fat from food, place the deep pan (or baking tray) below of the wire grill. When oven beeps, turn food over. After cooking, allow to rest covered with foil for 3 minutes. Use generated juice for gravy or sauce.

Fish					
No	Menu	Weight Limit	Food Temp.	Rack Position	Instructions
16	Tuna *1*2	0.8 kg	Refrigerated	4	Choose tuna fish steaks of 200 g weight and 2.5 cm thickness each. Brush tuna with oil or melted butter, season as desired. Place tuna on the wire grill. Put into the oven. To catch drippings or fat from food, place the deep pan (or baking tray) below of the wire grill. When oven beeps, turn food over. After cooking, allow to rest covered with foil for 3 minutes. Use generated juice for gravy or sauce.
17	Shrimp *1*2	0.6 kg	Refrigerated	4	Brush shrimp with oil or melted butter, season as desired. Place shrimp on the deep pan. Put into the oven. When oven beeps, turn food over. After cooking, allow to rest covered with foil for 5 minutes. Use generated juice for gravy or sauce.
18	Scallops *2	0.6 kg	Refrigerated	3	Put sherry with scallops. Place scallops on the deep pan. Brush melted butter over scallops. Cover with breadcrumbs. Add melted butter over breadcrumbs. Put into the oven. After cooking, allow to rest covered with foil for 5 minutes. Use generated juice for gravy or sauce.

Vegetable					
No	Menu	Weight Limit	Food Temp.	Rack Position	Instructions
19	Grilled vegetables *1*2	0.8 kg	Refrigerated	4	<p>Ingredients eggplants, cut into 1-2 cm thickness zucchini, cut into 1-2 cm thickness onions, cut into wedges sweet peppers, cut in half lengthwise and discard seeds, whole cherry tomatoes, mushrooms-cut in half, butter (or oil)</p> <p>Method Brush vegetables with melted butter or oil and season as desired. Place food on the deep pan. Put into oven. When oven beeps, turn food over. After cooking, allow to rest covered with foil for 5 minutes. Use generated juice for gravy or sauce.</p>

Potato					
No	Menu	Weight Limit	Food Temp.	Rack Position	Instructions
20	Roast potatoes *1*3*5*8	1.0 kg	Room	2	Choose small potatoes (150-200 g each). Peel, wash, dry and cut potatoes into halves. Mix potatoes with salt, pepper and oil or melted butter. Place potatoes in a heat proof pan. Put into the oven. When oven beeps, turn food over.
21	Gratinated potatoes *3*8	1.0 kg	Room	2	Cut pre-cooked gratin potatoes with slices. Place potatoes in a heat proof pan, cover with grated cheese (30 g per 500 g gratin potatoes). Put into the oven.

Bread/Pastries					
No	Menu	Weight Limit	Food Temp.	Rack Position	Instructions
22	Umm Ali *3*8	1 serving	Room	3	<p>Ingredients 4 all-butter croissants, 2 tbsp. raisins or dried mixed berries, 2 tbsp. flaked/slivered almonds, 2 tbsp. pine nuts, 2 tbsp. roughly chopped shelled unsalted pistachios, 250 ml milk, 5 tbsp caster sugar, ¼ tsp ground cinnamon, 2 tsp orange blossom water, 250 ml whipping cream, 4 tbsp shredded coconut, 1 small egg (optional)</p> <p>Method Tear up the croissants into bite-size pieces, place on the baking sheet and bake in the 180 °C oven for 10 minutes until crisp and golden. Spread the baked croissant pieces across the base of a baking dish, about 23 cm in square. Sprinkle over the raisins, almonds, pine nuts and pistachios, making sure they are spread evenly. Heat the milk in a heavy-based saucepan over a medium heat, add 3 tablespoons of the sugar and mix well to dissolve. Reduce the heat to low, add the cinnamon and orange blossom water and heat through at a gentle simmer for 3-4 minutes. Remove the pan from the heat and leave it to cool so that the egg will not scramble when it's added to it. Put the cream and the remaining sugar in a mixing bowl and whisk until the mixture forms soft peaks. Sprinkle in the coconut and gently fold to incorporate. Add the egg to the cool milk mixture and whisk to combine. Ladle the mixture into the baking dish and spread the whipped cream over the top. Put into the oven.</p>

Bread/Pastries					
No	Menu	Weight Limit	Food Temp.	Rack Position	Instructions
23	Baklava *3*8	1 serving	Room	3	<p>Ingredients 175 g melted butter, 400 g thawed filo pastry, 2 tbsp. lemon juice, 4 tbsp. clear thick honey, 59 g caster sugar, finely grated rind of 1 lemon, 2 tsp cinnamon, 200 g blanched almonds copped, 200 g chopped walnuts, 75 g chopped pistachios or hazelnuts 359 g caster sugar, 115 g clear honey, 600 ml water, 2 strips of thinly pared lemon rind, 1 tsp orange flower or rose water</p> <p>Method Brush the base of a shallow 30x20 cm loose-bottomed or Swiss roll tin (jelly roll pan) with a little of the melted butter. Using the tin as a guide, cut the sheets of filo pastry with a sharp knife so that they fit the tin exactly. To make filing, place the lemon juice, honey and sugar in a pan and heat gently until dissolved. Stir in the lemon rind, cinnamon and chopped nuts. Mix thoroughly. Spread half the filling over the pastry, cover with three layers of the filo pastry and butter then spread the remaining filling over the pastry. Finish by using up the remaining sheets of pastry and butter on top and brush the top of the pastry liberally with butter. Using a sharp knife, carefully mark the pastry into squares or diamond shape, almost cutting through the filing. Put into the oven. Place the caster sugar, honey, water and lemon rind in a pan and stir over a low heat until the mixture has thickened slightly. Take the syrup off the heat and leave to cool slightly. Remove the baklava from the oven. Remove and discard the lemon rind from the syrup and stir in the orange flower or rose water, then pour over the pastry. Leave to soak for 6 hours. Cut into squares and serve, decorated with chopped pistachios.</p>

Bread/Pastries					
No	Menu	Weight Limit	Food Temp.	Rack Position	Instructions
24	Kobaiba *3*8	1 serving	Room	2	<p>Ingredients 1 tbsp butter, 100 g coarsely ground or chopped walnuts, 750 g ground lamb (10 % fat), 500 g finely chopped onion, 1 tsp salt, 1 tsp freshly ground black pepper, ½ tsp ground allspice, 1 egg 500 g fine grain bulgur, 500 ml water, 500 g lean ground lamb or beef, 1 onion, 1 tsp salt, 1 tsp freshly ground black pepper 120 g room temperature butter, ½ cup blanched almond</p> <p>Method Melt the butter in a large saute pan set over medium heat, then add the walnuts and cook, stirring occasionally, for 10 to 15 minutes, until toasted. Remove from pan and add the ground lamb, onion, salt, pepper, and allspice. Cook, stirring often, until the juices evaporate, about 30 to 50 minutes. Remove from heat and stir in the toasted walnuts. Set aside to cool slightly, then add the egg and mix thoroughly. Put the bulgur in the bowl of a food processor, then add the water. Stir well with a fork and let sit for 15 minutes. Add the lamb or beef, onion, salt, and pepper, then pulse about 3 times, or just until malleable paste. Butter a 40x25 cm baking dish and spread half of the bulgur paste into the dish, patting with moistened hands to make it as even as possible. Next spread the filling, again making it as even as possible. Finish with the rest of the bulgur paste, pressing down with our hands to ensure that it sticks to the filling. Cut into 16 diamond shapes, make a small indentation in the center of each diamond, and press one almond in each dimple. Spread the butter over the kobaiba using hand. Put into the oven. Remove from the oven and sprinkle some water over top with fingers.</p>

Bread/Pastries					
No	Menu	Weight Limit	Food Temp.	Rack Position	Instructions
25	Cookies *6	1 serving	Refrigerated	2	<p>Ingredients (2 servings) 250 g butter, 250 g sugar, 500 g flour, 3 eggs, 2 g salt, 1 packet vanilla sugar (ca. 8 g), 1 egg yolk and milk</p> <p>Method Cream together the butter, sugar, vanilla sugar and salt. Gradually add the eggs. Add the flour and mix it with the butter mixture. Cover and put the dough overnight in a refrigerator. Portions of the dough roll out about 5 mm thick. Cut out the rolled out dough with various cutters and place on greased baking sheet. Mix the egg yolk with a little bit milk and brush the surface of the cookies with it. Put into the oven.</p>
26	Muffins *3*7*8	1 serving	Room	2	<p>Ingredients 150 g flour, 1 ½ tsp baking powder, 60 g granulated sugar, 1 egg beaten, 130 ml milk, 70 ml vegetable oil, ½ tsp vanilla extract, 50 g semisweet chocolate chips, 50 g chopped walnuts, sifted confectioners' sugar</p> <p>Method Combine flour and sugar in a mixing bowl; make a well in center of mixture. Combine remaining ingredients except for confectioners' sugar; add to dry ingredients, stir just until moistened. Spoon into greased and floured muffin pan, filling about two-thirds full. Put into the oven. Remove from pans and sprinkle with confectioners' sugar.</p>
27	Buns *3*6*8	1 serving	Room	3	<p>Ingredients 400 g flour, 200 ml warm milk, 70 g sugar, 30 g yeast, 50 g butter, 15 g vanilla sugar, 2 g salt, 120 g raisins (optional)</p> <p>Method Put the flour in a mixing bowl and make a well. Add yeast and 20 g sugar to milk and mix. Pour the liquid into the well and cover with some flour. Leave to rise in a warm place until cracks appear on the surface. Add the remaining sugar, softened butter, vanilla sugar, salt and knead into a smooth yeast dough. Let the dough rise in a warm place until it doubles in size. Put raisins into the batter. Divide the dough into 12 pieces and shape into rounds. Place on a baking sheet lined with parchment paper. Let rise again and brush with milk. Put into the oven.</p>

54 OPERATION

Bread/Pastries					
No	Menu	Weight Limit	Food Temp.	Rack Position	Instructions
28	Brownies *3*5*8	1 serving	Room	2	<p>Ingredients 225 g melted butter, 400 g white sugar, 100 g cocoa powder, 1 tsp vanilla extract, 2 eggs, 130 g all-purpose flour, ½ tsp baking powder, ½ tsp salt, 70 g walnut halves</p> <p>Method Combine the melted butter, sugar, cocoa powder and mix well. Add vanilla, eggs, flour, baking powder and salt. Spread the batter into the heat proof pan lined with baking paper. Decorate with walnut halves, if desired. Put into the oven.</p>
29	Apple pie *3*8	1 serving	Refrigerated	3	<p>Ingredients 150 g white sugar, 2 tbsp all-purpose flour, ½ tsp ground cinnamon, ¼ tsp ground nutmeg, ½ tsp lemon zest, 1.2 kg thinly sliced apples, 2 tsp lemon juice, 1 tbsp butter, 1 recipe pastry for a 9 inch double crust pie, 4 tbsp milk (optional)</p> <p>Method Mix together the sugar, flour, cinnamon, nutmeg and lemon zest. Line one crust in a 9-inch deep-dish pie pan. Layer 1/3 of apples on pie crust. Sprinkle with sugar mixture and repeat until done. Sprinkle with lemon juice and dot with butter. Place second pie crust on top of filling and flute the edges. Cut vents in top crust and brush with milk for a glazed appearance if desired. Put into the oven.</p>

Pizza					
No	Menu	Weight Limit	Food Temp.	Rack Position	Instructions
30	Frozen pizza (thin base) ^{*3}	0.3 kg	Frozen	2	Place frozen pizza on the wire grill. Put into the oven. Use only one frozen pizza at a time.
31	Frozen pizza (thick base) ^{*3}	0.5 kg	Frozen	2	Place frozen pizza on the wire grill. Put into the oven. Use only one frozen pizza at a time.

Pizza					
No	Menu	Weight Limit	Food Temp.	Rack Position	Instructions
32	Homemade pizza *3*8	1 serving	Room	2	<p>Ingredients 20 g yeast, 200 ml warm water, 5 g salt, 350 g flour, 10 g sugar, 10 g vegetable oil, 1 small jar tomato sauce, 250 g grated cheese, 200 g Mozzarella cheese, 1 small can of sliced mushrooms, oregano, salt, pepper</p> <p>Method Dissolve yeast in warm water. Stir in salt and sugar. Add flour slowly, kneading constantly. Add oil and keep kneading. If dough is sticky, add a little more flour. Cover dough and allow to rise for ½ hour. Using floured hands, knead dough and spread it on greased baking sheet with fingertips. Spread tomato sauce over dough, add toppings in layers. Sprinkle cheese over dough. Put into the oven.</p>

*1 After the BEEP, turn the food over.

*2 Use wire grill over the deep pan (or baking tray).

*3 Use wire grill.

*4 Use your roasting pot.

*5 Use your heat proof pan.

*6 Use your baking sheet.

*7 Use your muffin pan.

*8 Use your own cooking containers.

Air Fry

This feature automatically increases the entered temperature by 25 °C for optimal performance when using Air Fry.

The Air Fry function is specially designed for oil-free frying.

- If cooking multiple batches, the later batches may take less time to cook.
- Wet batters and coatings will not crisp or set when using the Air Fry mode.

NOTE

- No preheating is required when using the Air Fry mode.

Tips for Air Fry

- For best results, cook food on a single rack placed in positions suggested in the chart in this manual.

- Spread the food out evenly in a single layer.
- Use either an air fry tray or a dark baking tray with no sides or short sides that does not cover the entire rack. This allows for better air circulation.
- If desired, spray the baking tray or air fry tray with a pan spray. Use an oil that can be heated to a high temperature before smoking, such as avocado, grapeseed, peanut or sunflower oil.
- Place a foil-lined baking tray on a rack in position 1 to catch the oil falling from the food. For high-fat foods like chicken wings, add a few sheets of parchment paper to absorb the fat.
- Check food often and shake it or turn it over for crisper results.
- Prepared frozen foods may cook faster with the Air Fry mode than stated on the package. Reduce the cooking time by about 20 percent, check food early, and adjust cooking time as needed.
- Use a food thermometer to make sure food has reached a safe temperature for consumption. Eating undercooked meats can increase your risk of food-borne illness.
- For the crispiest results, dredge fresh chicken wings or tenders in seasoned flour. Use 1/3 cup flour for 2 pounds of chicken.
- Turn on your exhaust hood at a high fan setting before you start Air Fry and leave it on for 15 minutes after you're done.
- Open a window or sliding glass door, if possible, to make sure the kitchen is well-ventilated.
- Keep the oven free from grease buildup. Wipe down the interior of the oven before and after air frying (once the oven has cooled).
- Run oven cleaning cycles (Easy Clean or Pyrolysis) regularly, depending on how often and what types of food you Air Fry.
- Avoid opening the oven door more than necessary to help maintain the oven temperature, prevent heat loss, and save energy.
- Air-frying fresh chicken pieces such as wings or drumsticks with the skin left on can produce smoke as the fat renders at high temperatures. If the smoke is excessive, use the Roast mode instead of Air Fry.

Recommendations When Air Frying High-Fat Foods

Foods high in fat will smoke when using the Air Fry mode. For best results, follow these recommendations when air frying foods that are high in fat, such as chicken wings, turkey legs, lamb chops, ribs, duck breasts, or some plant-based proteins.

CAUTION

- Never cover slots, holes, or passages in the oven bottom or cover entire racks with materials such as aluminum foil. Doing so blocks airflow through the oven and can result in carbon monoxide poisoning. Aluminum foil can also trap heat, causing a fire hazard or poor oven performance.
 - Clean the grease filters on your exhaust hood regularly.
-

Recommended Air Frying Guide

Cooking on a baking tray

- Arrange food evenly in a single layer.
- Place the baking tray on rack position ③.
- Flip food over during cooking to avoid burning it.

POTATOES-Frozen				
Menu	Quantity (kg)	Temp. (°C)	Rack Position	Time (minute)
Frozen french fries (Shoestring)	0.4	200	3	15-25
Frozen french fries (Crinkle cut, 10x10 mm)	0.8	200	3	20-30
Frozen sweet potato fries	0.6	200	3	17-27
Frozen tater tots	1.0	220	3	17-27
Frozen hash browns	1.0	220	3	15-25

POTATOES-Fresh/Homemade				
Menu	Quantity (kg)	Temp. (°C)	Rack Position	Time (minute)
Homemade potato wedges	1.3	230	3	25-35

CHICKEN-Frozen				
Menu	Quantity (kg)	Temp. (°C)	Rack Position	Time (minute)
Frozen chicken nuggets, Crispy	0.6	200	3	15-25
Frozen chicken strips	0.8	210	3	20-30

CHICKEN- Fresh, Skin on				
Menu	Quantity (kg)	Temp. (°C)	Rack Position	Time (minute)
Fresh chicken wings	1.2	230	3	27-37
Fresh chicken drumsticks	2.0	230	3	35-45
Thighs	1.2	230	3	27-37
Breasts	1.2	230	3	27-37

OTHER				
Menu	Quantity (kg)	Temp. (°C)	Rack Position	Time (minute)
Frozen onion rings, Breaded	0.5	200	3	15-25
Frozen spring rolls (20 g each)	1.2	210	3	20-30
Frozen coconut shrimps	0.7	200	3	20-30
Fresh scallops on the half shell	1.0	210	3	15-25
Fresh shrimps	1.0	200	3	20-30
Mixed vegetables	1.0	220	3	17-27

Cooking on an air fry tray

- Arrange food evenly in a single layer.
- Put a foil-lined baking pan on a rack in position ② to catch drips. If needed, add parchment paper to absorb oil and reduce smoking.
- Flip food over during cooking to avoid burning it.

POTATOES-Frozen				
Menu	Quantity (kg)	Temp. (°C)	Rack Position	Time (minute)
Frozen french fries (Shoestring)	0.4	200	3	15-25
Frozen french fries (Crinkle cut, 10x10 mm)	0.8	200	3	20-30
Frozen sweet potato fries	0.6	200	3	17-27
Frozen tater tots	1.0	220	3	17-27
Frozen hash browns	1.0	220	3	15-25

POTATOES-Fresh/Homemade				
Menu	Quantity (kg)	Temp. (°C)	Rack Position	Time (minute)
Homemade french fries (10x10 mm)	0.6	220	3	20-30

POTATOES-Fresh/Homemade				
Menu	Quantity (kg)	Temp. (°C)	Rack Position	Time (minute)
Homemade potato wedges	1.3	230	3	25-35

CHICKEN-Frozen				
Menu	Quantity (kg)	Temp. (°C)	Rack Position	Time (minute)
Frozen chicken nuggets, Crispy	0.6	200	3	15-25
Frozen chicken strips	0.8	210	3	20-30
Frozen hot wings, Bone-in	1.2	200	3	30-40

CHICKEN-Fresh, Skin on				
Menu	Quantity (kg)	Temp. (°C)	Rack Position	Time (minute)
Fresh chicken wings	1.2	230	3	27-37
Fresh chicken drumsticks	2.0	230	3	35-45
Thighs	1.2	230	3	27-37
Breasts	1.2	230	3	27-37

OTHER				
Menu	Quantity (kg)	Temp. (°C)	Rack Position	Time (minute)
Frozen onion rings, Breaded	0.5	200	3	15-25
Frozen spring rolls (20 g each)	1.2	210	3	20-30
Frozen coconut shrimps	0.7	200	3	20-30
Fresh scallops on the half shell	1.0	210	3	15-25

Air Sous-Vide

This feature is only available on some models.

Air Sous-Vide cooking uses air to cook foods "low and slow." Use it to cook meat, fish, seafood, poultry or vegetables. Food must be vacuum packed in pouches.

It is not necessary to preheat the oven when using Air Sous-Vide.

Refer to the cooking guide for recommended Air Sous-Vide settings.

Benefits of Air Sous-Vide

The lower temperatures and long cooking times used in Air Sous-Vide cooking provide many benefits.

- **Healthier**

Compared to other cooking methods, Air Sous-Vide retains most of the original nutrients in food.

- **Safe and Convenient**

The long cooking times used in Air Sous-Vide cooking allow food to be pasteurized. Because food is vacuum packed before cooking, the unopened pouches can be quickly chilled then easily stored after cooking.

- **Crisp and Moist Results**

The fine temperature control of Air Sous-Vide cooking is an excellent way to achieve the perfect texture when cooking meat and poultry. The low temperatures used retain more of the moisture in food than conventional cooking methods. After cooking, a final sear in a frying pan adds the perfect crisp finish.

Recommended Air Sous-Vide Guide

The size, weight, thickness, starting temperature, and your personal preferences will affect operating times. This guide is only for reference. Adjust cook time according to your preference.

- Rack: Rack Position

Food	Quantity (each)	Rack	Temp. (°C)	Time (min.)		
				Min	Target	Max
Beef steak	2.5 cm thick 0.3~0.5 kg	2	58	-	150	180
Chicken breast	0.1~0.2 kg	2	67	-	120	180
Salmon	2.5 cm thick 0.1~0.2 kg	2	60	-	120	150
Asparagus	15~20 g	2	85	20	30	45

- Cook 30 minutes or 1 hour more if you cook meats thicker than 2.5 cm.
- If you use larger cuts of meat, cut to match the recommended weight. Be careful not to put pieces of meat too close together.

Information for Test Institutes

This table is only for use by test institutes. It includes the best settings for the test recipes out of the standard IEC 60350-1.

Acc: Accessories

Rack: Rack Position

Dish	Heating Mode	Temp. (°C)	Acc	Rack	Preheat	Time (minute)	Handlings
Small cake	Top Bottom Heat	170	Baking tray	3	Yes	20-30	-
	Hot Air	150	Baking tray	3	Yes	20-30	-
	Hot Air	150	Baking tray / Deep pan	4 / 2	Yes	25-35	Baking tray at the 4, Deep pan at the 2 from down
Sponge cake	Top Bottom Heat	170	Wire grill	2	Yes	20-30	-
	Hot Air	160	Wire grill	3	Yes	30-40	-

62 OPERATION

Dish	Heating Mode	Temp. (°C)	Acc	Rack	Preheat	Time (minute)	Handlings
Apple pie	Top Bottom Heat	180	Wire grill	1	No	65-75	One tin in the left back and the other one in the right front
	Hot Air	170	Wire grill	2	No	65-75	
Pastry stripes	Top Bottom Heat	170	Baking tray	3	Yes	20-30	-
	Hot Air	140	Baking tray	3	Yes	20-30	-
	Hot Air	140	Baking tray / Deep pan	4 / 2	Yes	20-30	Baking tray at the 4, Deep pan at the 2 from down
Toast	Large Grill	L1	Wire grill	4	Yes (5 min.)	2-4	-
Beef steak	Large Grill	L3	Wire grill	4 / 1	Yes (5 min.)	10-15 each side	Turn after half time
Meringue	Hot Air	80	Baking tray	3	No	120-150	-
Roast Chicken	Roasting	190	Wire grill / Deep pan	2	Yes	55-65	Turn after half time

SMART FUNCTIONS

LG ThinQ Application

This feature is only available on models with Wi-Fi. The **LG ThinQ** application allows you to communicate with the appliance using a smartphone.

LG ThinQ Application Features

Communicate with the appliance from a smartphone using the convenient smart features.

• Settings

- Allows you to set various options on the oven and in the application.

• Smart Diagnosis

- This function provides useful information for diagnosing and solving issues with the appliance based on the pattern of use.

• Monitoring

- This function helps you check the current status, remaining time, cook settings and end time in one place.

• Product Notifications

- Turn on the Push Alerts to receive appliance status notifications. The notifications are triggered even if the **LG ThinQ** application is not open.

• Timer

- You can set the timer from the application.

• Firmware Update

- Keep the appliance updated.

NOTE

- In the following cases, you must update the network information for each appliance in the **LG ThinQ** application under **Device Cards** → **Settings** → **Change Network**.
 - wireless router is changed
 - wireless router password is changed
 - Internet service provider is changed
- To disconnect the appliance from the **Wi-Fi** network, delete the appliance from the list of connected products in the **LG ThinQ** application.

- The application is subject to change for appliance improvement purposes without notice to users.
- Functions may vary by model.

Installing LG ThinQ Application and Connecting an LG Appliance

Scan the QR code attached to the product using the camera or a QR code reader application on your smartphone.

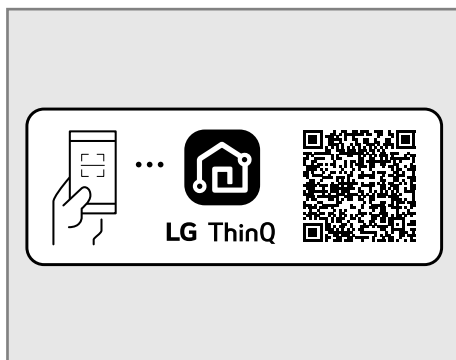

NOTE

- To verify the Wi-Fi connection, check that the  icon on the control panel is lit.
- The appliance supports 2.4 GHz Wi-Fi networks only. To check your network frequency, contact your Internet service provider or refer to your wireless router manual.
- **LG ThinQ** is not responsible for any network connection problems or any faults, malfunctions, or errors caused by network connection.
- The surrounding wireless environment can make the wireless network service run slowly.
- If the appliance is having trouble connecting to the Wi-Fi network, it may be too far from the router. Purchase a Wi-Fi repeater (range extender) to improve the Wi-Fi signal strength.

NOTE

- The network connection may not work properly depending on the Internet service provider.
 - The Wi-Fi may not connect or the connection may be interrupted because of the home network environment.
 - If the appliance cannot be connected due to problems with the wireless signal transmission, unplug the appliance and wait about a minute before trying again.
 - If the firewall on your wireless router is enabled, disable the firewall or add an exception to it.
 - The wireless network name (SSID) should be a combination of English letters and numbers. (Do not use special characters.)
 - Smartphone user interface (UI) may vary depending on the mobile operating system (OS) and the manufacturer.
 - If the security protocol of the router is set to **WEP**, network setup may fail. Change the security protocol (**WPA2** is recommended), and connect the product again.
 - To reconnect the appliance or add another user, press and hold the **Wi-Fi** button for 3 seconds to temporarily turn it off. Run the **LG ThinQ** application and follow the instructions in the application to register the appliance.
-

Open Source Software Notice Information

To obtain the source code that is contained in this product, under GPL, LGPL, MPL, and other open source licenses that have the obligation to disclose source code, and to access all referred license terms, copyright notices and other relevant documents, please visit <https://opensource.lge.com>.

LG Electronics will also provide open source code to you on CD-ROM for a charge covering the cost of performing such distribution (such as the cost of media, shipping, and handling) upon email request to opensource@lge.com.

This offer is valid to anyone in receipt of this information for a period of three years after our last shipment of this product.

Smart Diagnosis Feature

Use this feature to help you diagnose and solve problems with your appliance.

NOTE

- For reasons not attributable to LGE's negligence, the service may not operate due to external factors such as, but not limited to, Wi-Fi unavailability, Wi-Fi disconnection, local app store policy, or app unavailability.
 - The feature may be subject to change without prior notice and may have a different form depending on where you are located.
-

Using LG ThinQ to Diagnose Issues

If you experience a problem with your Wi-Fi equipped appliance, it can transmit troubleshooting data to a smartphone using the **LG ThinQ** application.

- Launch the **LG ThinQ** application and select the **Smart Diagnosis** feature in the menu. Follow the instructions provided in the **LG ThinQ** application.

Using Audible Diagnosis to Diagnose Issues

Follow the instructions below to use the audible diagnosis method.

- Launch the **LG ThinQ** application and select the **Smart Diagnosis** feature in the menu. Follow the instructions for audible diagnosis provided in the **LG ThinQ** application.
 - 1) Press **Start** button for 3 seconds.
 - If the display has been locked, you must deactivate the lock and then reactivate it.

- 2) Place your phone's mouthpiece near the top left corner of the screen.

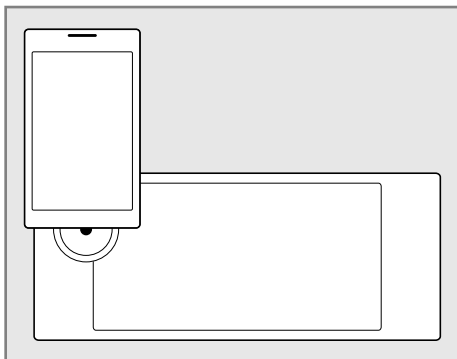

- 3) Keep the phone in place until the tone transmission has finished. The display will count down the time. Once the countdown is over and the tones have stopped, the diagnosis will be displayed in the application.

NOTE

- For best results, do not move the phone while the tones are being transmitted.
-

MAINTENANCE

Cleaning

Interior

WARNING

- Never wipe a warm or hot porcelain surface with a damp sponge; it may cause chipping or crazing (tiny hairlike cracks).

CAUTION

- Do not use oven cleaners, steam cleaners, harsh chemical cleaners, bleach, vinegar, steel scouring pads, or abrasive pads or cleansers to clean the oven, as they can permanently damage the oven surface.
- Do not clean the gasket.
- Do not clean the interior with the oven light on.
- To prevent burns, wait until the oven has cooled down before touching any of its parts.

Do not use oven cleaners to clean the oven cavity. Use the product's **EasyClean** function regularly to clean light soil. For stubborn soil, use the **Pyrolysis** function or clean manually using the following tips.

- A plastic spatula can be used as a scraper to scrape off any chunks or debris before and after oven cleaning.
- Using the rough side of a non-scratch scouring pad may help to take off burnt-on stains better than a soft sponge or towel.
- Certain non-scratch scrubbing sponges, such as those made of melamine foam, available at local stores, can also help improve cleaning.
- Food spills should be cleaned when the oven cools immediately after the cooking has ended. Leaving spills or splatter unattended to may cause surface etching or discoloration.
- At high temperature, foods react with porcelain and a permanent dull spot can result. When cleaning a spot, use only non-abrasive cleaners or scrubbers.
- When cleaning a spot, use only non-abrasive cleaners or scrubbers.

Exterior

Painted and Decorative Trim

For general cleaning, use a cloth with hot soapy water. For more difficult soils and built-up grease, apply a liquid detergent directly onto the soil. Leave it on for 30 to 60 minutes. Rinse with a damp cloth and dry. Do not use abrasive cleaners.

Stainless Steel Surfaces

WARNING

- To avoid scratches, do not use steel wool pads.

NOTE

- To clean the stainless steel surface, use warm sudsy water or a stainless steel cleaner or polish.
- Always wipe in the direction of the metal surface finish.
- Stainless steel appliance cleaner or polish can be purchased online or from most retailers of appliances or home goods.

- 1) Place a small amount of stainless steel appliance cleaner or polish on a damp cloth or paper towel.
- 2) Clean a small area, rubbing with the grain of the stainless steel if applicable.
- 3) Dry and buff with a clean, dry paper towel or soft cloth.
- 4) Repeat as necessary.

Oven Door

CAUTION

- Do not use harsh cleaners or harsh abrasive cleaning materials on the outside of the oven door. Doing so can cause damage.
- Do not use harsh abrasive cleaners or sharp metal scrapers to clean the oven door glass, since they can scratch the surface, which may result in shattering of the glass.

- Do not use oven cleaners, cleaning powders, or harsh abrasive cleaning materials on the outside of the oven door.

- Use soapy water to thoroughly clean the oven door. Rinse well. Do not immerse the door in water.
- You may use a glass cleaner on the outside glass of the oven door. Do not spray water or glass cleaner on the door vents.
- Do not clean the oven door gasket. The oven door gasket is made of a fiberglass material that is essential for a good seal. Care should be taken not to rub, damage, or remove this gasket.

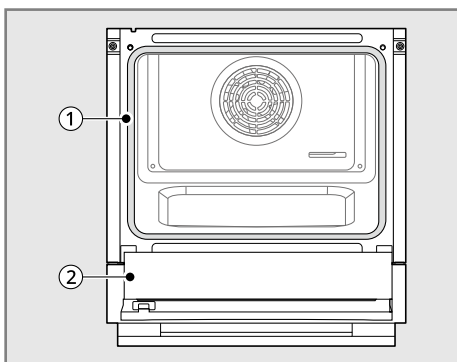

①	Don't hand clean oven door gasket
②	Do hand clean door

- Refer to "Removing, Assembling and Dismantling the Oven Door" for disassembly the door.

Oven Racks

Remove the oven racks before cleaning them.

- 1) Clean with a mild, abrasive cleaner.
 - Food spilled into the tracks could cause the racks to become stuck.
- 2) Rinse with clean water and dry.

Accessories

- Clean the wire grill, baking tray, and other accessories with a soft cloth and hot, soapy water.

- Do not clean the accessories in the dishwasher.

Lamp Cover

Disassemble the lamp cover before cleaning it.

- Refer to "**Changing the Oven Light**" for disassembly the lamp cover.
- Clean the lamp cover with a soft cloth and hot, soapywater.

EasyClean

The **EasyClean** feature takes advantage of LG's new enamel to help lift soils without harsh chemicals, and it runs using **ONLY WATER** for just 10 minutes in low temperatures to help loosen **LIGHT** soils before hand cleaning.

Your LG oven gives you the option of cleaning with **LESS HEAT, LESS TIME, and virtually NO SMOKE OR FUMES**. You can reduce energy use by cleaning light oven soils with the **EasyClean** feature instead of Pyrolysis.

Benefits of EasyClean

- Helps loosen light soils before hand-cleaning.
- **EasyClean** only uses water; no chemical cleaners.
- Makes for a better **Pyrolysis** experience.
 - Delays the need for a **Pyrolysis** cycle
 - Minimizes smoke and odors
 - Can allow shorter **Pyrolysis** time

When to Use EasyClean

- Example of oven soiling

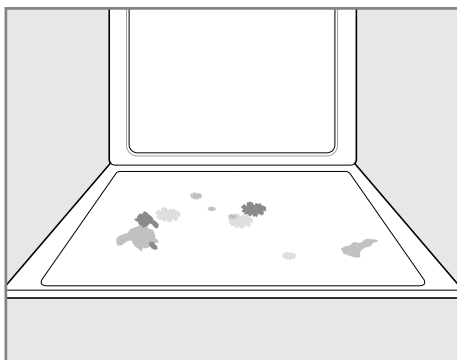

Case 1

- Soil pattern: Small drops or spots
- Types of soils: Cheese or other ingredients
- Common food items that can soil your oven: Pizza

Case 2

- Soil pattern: Light splatter
- Types of soils: Fat/grease
- Common food items that can soil your oven: Steaks, grilled / Fish, grilled / Meat roasted at low temperatures

EasyClean Instruction Guide

⚠ CAUTION

- The oven should be level to ensure that the bottom surface of the oven cavity is entirely covered by water at the beginning of the **EasyClean** cycle.
- Do not open the oven door during the **EasyClean** cycle. Water will not get hot enough if the door is opened during the cycle.
- Remove the baking tray, deep baking tray, wire grill, all cookware, aluminum foil, or any other material from the oven.

NOTE

- Allow the oven to cool to room temperature before using the **EasyClean** cycle. If your oven cavity is above 65 °C, the **EasyClean** cycle will not be activated until the oven cavity cools down.
- For best results, use distilled or filtered water. Tap water may leave mineral deposits on the oven bottom.
- Soil baked on through several cooking cycles will be more difficult to remove with the **EasyClean** cycle.
- If cleaning multiple baking trays, use an entire bottle of water to clean each baking tray. Do not spray water directly on the door. Doing so will result in water dripping to the floor.
- It is normal for the fan to operate during the **EasyClean** cycle.
- Using commercial oven cleaners or bleach to clean the oven is not recommended. Instead, use a mild liquid cleanser with a pH value below 12.7 to avoid discoloring the enamel.

- 1) Remove oven racks and accessories from the oven.
- 2) Scrape off and remove any burnt-on debris with a plastic scraper.

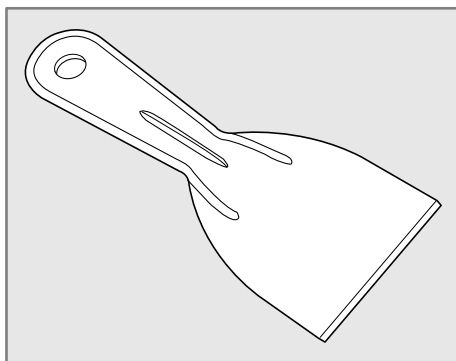

- Suggested plastic scrapers:
 - Hard plastic spatula
 - Plastic pan scraper
 - Plastic paint scraper
 - Old credit card

- 3) Fill a spray bottle with 500 ml of water and use the spray bottle to thoroughly spray the inside surfaces of the oven.
- 4) Use at least 50 ml of the water in the bottle to completely saturate the soil on both the walls and in the corners of the oven.

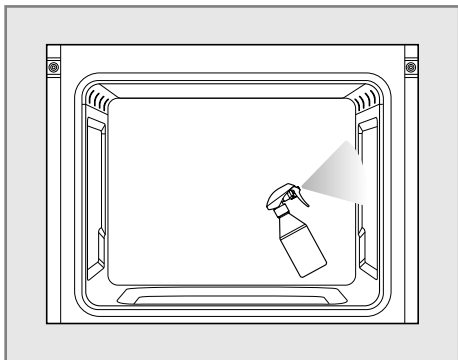

- 5) Spray or pour 450 ml of water onto the bottom center of the oven cavity. The indentation on the oven bottom should be fully covered to thoroughly soak all soils. Add water if necessary.
- 6) Turn and push the control knob to select **EasyClean**.
 - Icons appear when **EasyClean** is ready to use.



- 7) Press **Start** or push the control knob. The remaining time appears in the display.

⚠ CAUTION

- Some surfaces may be hot after the **EasyClean** cycle. Wear rubber gloves while cleaning to prevent burns.
- During the **EasyClean** cycle, the oven becomes hot enough to cause burns. Wait until the cycle is over before wiping the inside surface of the oven. Failure to do so may result in burns.
- Avoid leaning or resting on the oven door glass while cleaning the oven cavity.

- Do not use any steel scouring pads, abrasive pads or cleaners as these materials can permanently damage the oven surface.
- 8) A tone will sound at the end of the 10 minutes cycle and **End** appears in the display.
 - 9) After the cleaning cycle and during hand-cleaning, enough water should remain on the oven bottom to completely submerge all soils. Add water if necessary. Place a towel on the floor in front of the oven to capture any water that may spill out during hand-cleaning.
 - 10) Clean the oven cavity immediately after the **EasyClean** cycle by scrubbing with a wet, non-scratch scouring sponge or pad. (The scouring side will not scratch the finish.) Some water may spill into the bottom vents while cleaning, but it will be captured in a pan under the oven cavity and will not hurt the burner.
 - 11) Once the oven cavity is cleaned, wipe any excess water with a clean dry towel. Replace racks and any other accessories.
 - 12) If some light soils remain, repeat the above steps, making sure to thoroughly soak the soiled areas.
 - If stubborn soils remain after multiple **EasyClean** cycles, run the **Pyrolysis** cycle. Be sure that the oven cavity is empty of oven racks and other accessories, and that the oven cavity surface is dry before running the **Pyrolysis** cycle. Consult the **Pyrolysis** section of your owner's manual for further details.

NOTE

- The cavity gasket may be wet when the **EasyClean** cycle finishes. This is normal. Do not clean the gasket.
- If mineral deposits remain on the oven bottom after cleaning, use a cloth or sponge soaked in vinegar to remove them.

Pyrolysis (Model WSED7613*)

The **Pyrolysis** cycle uses extremely hot temperatures to clean the oven cavity. While running the **Pyrolysis** cycle, you may notice

smoking or an odor. This is normal, especially if the oven is heavily soiled. During **Pyrolysis**, the kitchen should be well ventilated to minimize the odors from cleaning.

Before Starting Pyrolysis

- The kitchen should be well ventilated to minimize the odors from cleaning. Open a window or turn on a ventilation fan or hood before **Pyrolysis**.
- Excess spillage must be removed before cleaning.
- Wipe any heavy spillovers on the bottom of the oven.
- Make sure that the oven light cover is in place and the oven light is off.
- Clean the frame of the oven and door with hot soapy water. Rinse well.

WARNING

- If the oven is heavily soiled with oil, use the **Pyrolysis** to clean the oven before using the oven again. If left, the oil could cause a fire.
- If there is a fire in the oven during **Pyrolysis**, turn the oven off and wait for the fire to go out. Do not force the door open. Introduction of fresh air at **Pyrolysis** temperatures may lead to a burst of flame from the oven. Failure to follow this instruction may result in severe burns.

CAUTION

- Do not use oven cleaners. Commercial oven cleaner or oven liner protective coating of any kind should not be used in or around any part of the oven.
- Remove the baking tray, deep baking tray, wire grill, all cookware, aluminum foil or any other material from the oven.
- The oven displays an F error code and sounds three long beeps during the **Pyrolysis** cleaning process if it malfunctions in the **Pyrolysis** mode. Switch off the electrical power to the main fuse or breaker and have the oven serviced by a qualified technician.
- If the **Pyrolysis** mode malfunctions, turn the oven off by pressing the **Stop** button and

disconnect the power supply. Have it serviced by a qualified technician.

- It is normal for parts of the oven to become hot during a **Pyrolysis** cycle. Avoid pressing the door, window or oven vent area during a **Pyrolysis** cycle.
- Do not leave small children unattended near the appliance. During the **Pyrolysis** cycle, the outside of the oven can become very hot to touch.
- If you have pet birds, move them to another well-ventilated room. The health of some birds is extremely sensitive to the fumes given off during the **Pyrolysis** cycle of an oven.
- Do not force the door open. This can damage the automatic door locking system. Use care when opening the oven door after the **Pyrolysis** cycle. Stand to the side of the oven when opening the door to allow hot air or steam to escape. The oven may still be VERY HOT.

NOTE

- The oven light cannot be turned on during a **Pyrolysis** cycle. The oven light cannot be turned on until the oven temperature has cooled below 250 °C after a **Pyrolysis** cycle is complete.
- Clean the frame of the oven and door with hot soapy water. Rinse well.
- Do not clean the gasket. The fiberglass material of the oven door gasket cannot withstand abrasion. It is essential for the gasket to remain intact. If you notice it becoming worn or frayed, replace it by a service technician .
- It is normal for the fan to operate during the **Pyrolysis** cycle.
- As the oven heats, you may hear sounds of metal parts expanding and contracting. This is normal and will not damage the oven.
- You may notice some white ash in the oven. Wipe it off with a damp cloth or a soap-filled steel wool pad after the oven cools. If the oven is not clean after one **Pyrolysis** cycle, repeat the cycle.
- After a **Pyrolysis** cycle, fine lines may appear in the porcelain because it went through heating and cooling. This is normal and will not affect performance.

- The **Pyrolysis** cycle cannot be started if the **Control Lock** feature is active.
- Once the **Pyrolysis** cycle is set, the oven door locks automatically. You will not be able to open the oven door until the oven is cooled. The lock releases automatically.
- Once the door has been locked, the lock  indicator light stops flashing and remains on. Allow about 15 seconds for the oven door lock to activate.

When to Use Pyrolysis

- Example of oven soiling

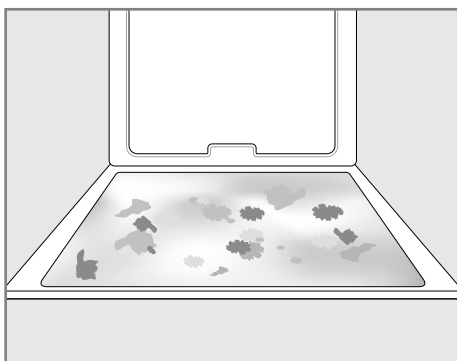

Case 1

- Soil pattern: Medium to heavy splatter
- Types of soils: Fat/grease
- Common food items that can soil your oven: Meat roasted at high temperatures

Case 2

- Soil pattern: Drops or spots
- Types of soils: Filling or sugar based soils
- Common food items that can soil your oven: Pies

Case 3

- Soil pattern: Drops or spots
- Types of soils: Cream or tomato sauce
- Common food items that can soil your oven: Casseroles

NOTE

- The **Pyrolysis** cycle can be used for soil that has been built up over time. The surface finish however can still deteriorate if heavily contaminated spillages from cooking foods are left uncleaned after each cooking cycle. The **Pyrolysis** function will not prevent this occurrence.

Setting Pyrolysis

- 1) Remove all racks and accessories from the oven.
- 2) Turn the control knob or press the **Menu** button to select **Pyrolysis**.
 - The **Pyrolysis** icon is flashing when **Pyrolysis** is selected.

	Pyrolysis Icon
---	-----------------------

- 3) Press the control knob to set.
 - The **Pyrolysis** icon stops flashing.
- 4) Turn the control knob to select **Pyrolysis** cycle depending on soil level (see table below).

Soil Level	Cycle Setting
Lightly Soiled Oven Cavity	1 h 15 min
Moderately Soiled Oven Cavity	1 h 30 min
Heavily Soiled Oven Cavity	2 h

- The **Cook Time** icon is flashing.

	Cook Time Icon
---	-----------------------

- 5) If desire, press the **Cook Time & End Time** button to use the cooking end time.
 - Set the end time using the control knob.
 - The **End Time** icon is flashing.

	End Time Icon
---	----------------------

- 6) Press the **Start** button or the control knob.

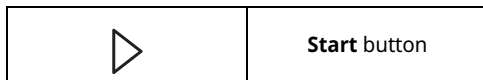

- 7) Once the **Pyrolysis** cycle is set, the oven door locks automatically and the lock icon  displays.

- You will not be able to open the oven door until the oven has cooled. The lock releases automatically when the oven has cooled.

CAUTION

- Do not force the oven door open when the lock icon is displayed. The oven door remains locked until the oven temperature has cooled. Forcing the door open will damage the door.
- It may become necessary to cancel or interrupt a **Pyrolysis** cycle due to excessive smoke or fire in the oven. To cancel the **Pyrolysis** function, press **Stop** button in the display.



Periodic Maintenance

Changing the Oven Light

The oven light is a standard 25-watt or 40-watt appliance halogen.

WARNING

- Ensure that the appliance is switched off before replacing the lamp to avoid the possibility of electric shock.
- Make sure that the oven and bulb are cool.
- Disconnect the electrical power to the appliance at the main fuse or circuit breaker panel. Failure to do so can result in severe personal injury, death, or electrical shock.
- Wear gloves while changing the oven light. Glass fragments from broken bulbs can cause risk of injury.

- If you apply force, the glass or oven may crack or be damaged.
- For changing the light socket, please contact a service technician.

- Unplug the oven or disconnect power.
- Turn the glass lamp cover counterclockwise to remove.
- Remove the halogen lamp from the socket and dispose it in an environmentally friendly way.
- Insert the new halogen lamp. Do not touch the lamp with your fingers when inserting as it can cause the lamp to fail.
- Insert the glass lamp cover and turn it clockwise.
- Plug in the range or reconnect the power.

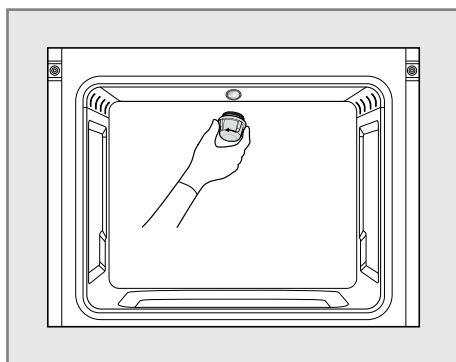

Removing, Assembling and Dismantling the Oven Door

Removing and dismantling the oven door may be needed to achieve better cleaning results. The oven door contains glass that can break. Care should be taken when removing, assembling and dismantling the oven door.

CAUTION

- To prevent burns, wait until the oven has cooled down before touching any of its parts.
- The door is very heavy. Be careful when removing, lifting and replacing the door.

- Do not lift the door by its handle. The handle is not designed to support the weight of the door when it has been removed from the oven.
- Do not hit the glass with pots, pans, or any other object.
- Scratching, hitting, jarring or stressing the glass may weaken its structure, causing an increased risk of breakage at a later time.
- Do not close the oven door until all the oven racks are fully in place.

- 4) Partially close the door to approximately 70 degrees (4). If the position is correct, the hinges (3) will move freely.

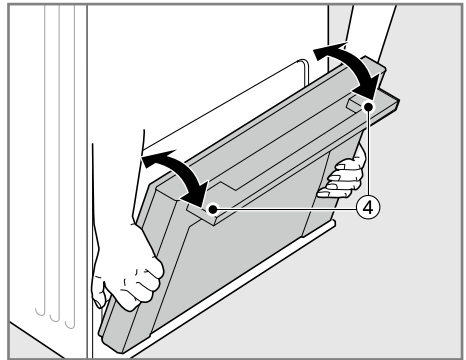

- 5) Lift and pull the door towards you until the hinge latches are completely loosened.

Removing the Oven Door

⚠ CAUTION

- Clip the clamp completely in order to prevent damaging the oven cavity.

- 1) Fully open the door.
- 2) Lift up the door clamp (2) and flip it towards the oven (1) completely.

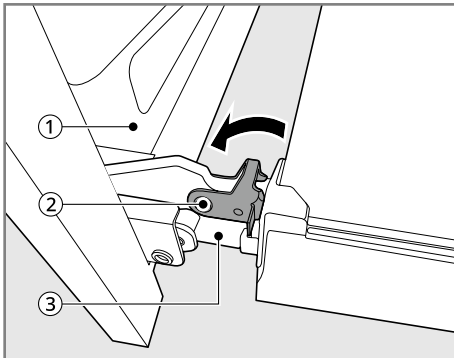

- 3) Firmly grasp both sides of the door at the top.

Assembling the Oven Door

- 1) Firmly grasp both sides of the door (1) near the top.

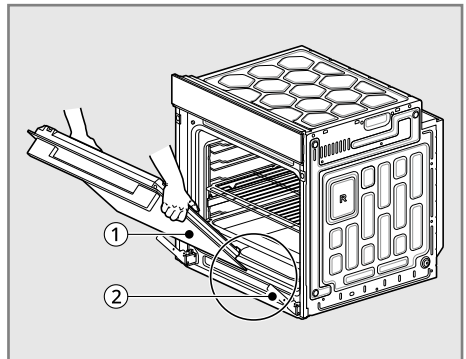

- 2) Fully insert the hinges ② into the slots ③.

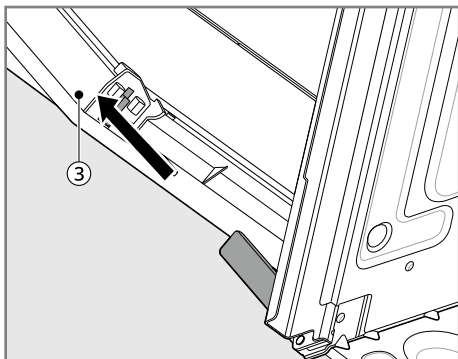

- 3) Slowly open the door fully. Make sure that the hinges ② are properly engaged in the slots ③.
 4) Lift up the door clamp ④ and flip it towards the oven door ① until it clicks into position.

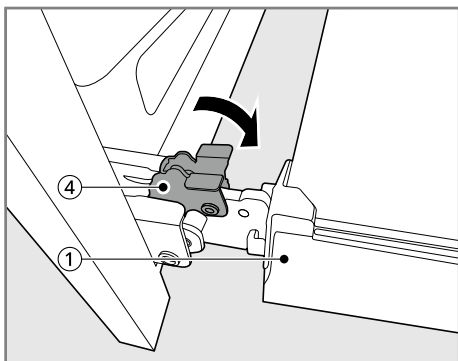

- 5) Close the door.

Dismantling the Oven Door

The oven door contains three layers of glass panels. Remove the oven door from the oven before dismantling the oven door.

- 1) Remove the oven door from the oven and place it on a soft, flat surface to prevent breakage and scratching with the door handle facing the floor.

- 2) Push the locks ① on both sides of the door top cover ② and pull forwards.

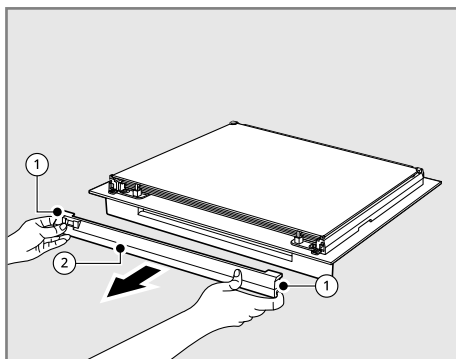

- 3) With both hands, grab and lift up the glass panel ③ slightly and pull forward to remove it from the oven door.
 Set aside the gasket (4 ea) inserted into glass. Repeat to remove all three layers of glass panels.

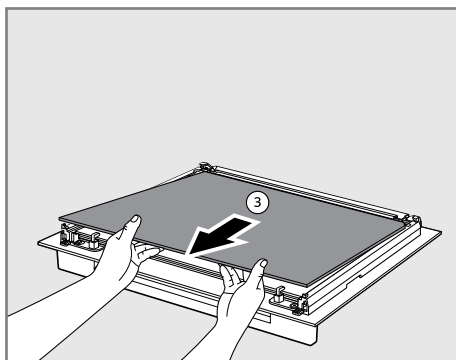

Assembling the Glass Panel

Assemble the glass panels in the reverse sequence of its removal.

- 1) Slide in the bottom glass panel into ② and the second glass panel into ① of the oven door.

- Place the glass panel as the **LG** printed side toward the oven door handle.

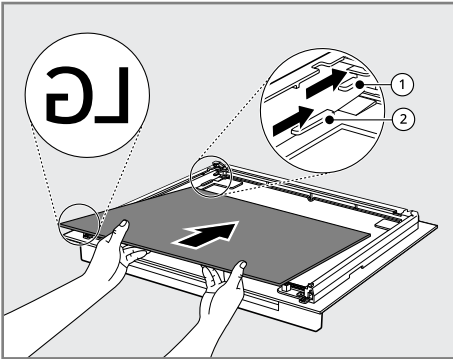

- If correctly placed, you will see **TOP** printed on the bottom of the glass panel to indicate the correct surface orientation.

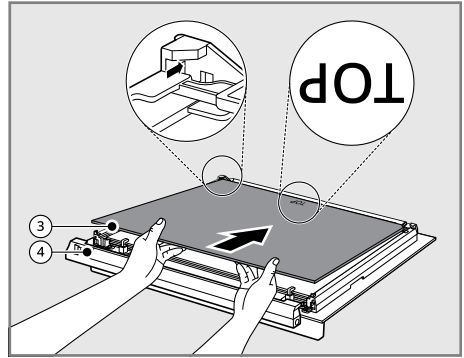

- 2) Assemble the 4 packings on the second glass panel as follows.
- The packings hold the glass in place reducing noise and vibration in a door.

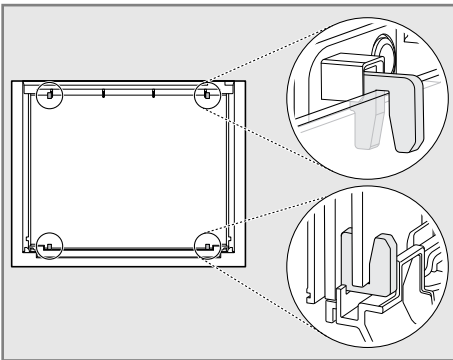

- 4) Assemble the door top cover (4) .
- Ensure that it is fixed (click!).

- 3) Slide in the top glass panel (3) on top of the second glass panel into the oven door.

TROUBLESHOOTING

FAQs

Frequently Asked Questions

Q: Is it normal to hear a clicking noise coming from the back of my oven when I am using it?

A: Your new appliance is designed to maintain a tighter control over your oven's temperature. You may hear your oven's heating elements click on and off more frequently on your new oven. This is NORMAL.

Q: Why is the colon in time flashing?

A: This means that the product has just been plugged in, or that it has experienced a power interruption. To clear the flashing time, press any button and reset the clock if needed.

Q: During convection cooking the fan stops when I open the door. Is that normal?

A: Yes, this is normal. When the door is opened, the convection fan will stop until the door is closed.

Q: Can I use aluminum foil to catch drippings in my oven cavity?

A: Never use aluminum foil to line the bottom or sides of the oven. The foil will melt and stick to the bottom surface of the oven and will not be removable. Use a foil-lined sheet pan placed on a lower oven rack to catch drippings instead. Never place any rack, tray or pan on the base of the oven. (If foil has already melted onto the bottom of the oven, it will not interfere with the oven's performance.)

Q: Can I use aluminum foil on the racks?

A: Do not cover racks with aluminum foil. Covering entire racks with foil restricts air flow, leading to poor cooking results. Use a sheet pan lined with foil under fruit pies or other acidic or sugary foods to prevent spillovers from damaging the oven finish.

CAUTION

- Foil may be used to wrap food in the oven, but do not allow the foil to come into contact with the exposed heating/grilling elements in the oven. The foil could melt or ignite, causing smoke, fire, or injury.
-

Q: Can I leave my racks in the oven when running a Pyrolysis cycle?

A: No. Remove all items from the oven before starting a **Pyrolysis** cycle.

Q: What should I do if my racks are sticky and have become hard to slide in and out?

A: Over time, the racks may become hard to slide in and out. Apply a small amount of olive oil to the sides of the racks. This will work as a lubricant for easier gliding.

Q: Should I grill with the door open or closed?

A: Your electric oven isn't designed for open door grilling. If you grill with the oven door open, it can damage the oven knobs or display.

Q: Why aren't the function buttons working?

A: Check if **Control Lock** is activated. The lock icon  will show in the display if **Control Lock** is activated. To deactivate **Control Lock**, refer to the **Setting Control Lock** in the **Operation** chapter.

Q: How can I help keep children safe around the appliance?

A: Children should be supervised around the appliance whenever it is in use, and after use until the oven surfaces have cooled. You can also use **Control Lock** to prevent children from accidentally turning on the oven. **Control Lock** disables most control panel buttons. Refer to the **Setting Control Lock** in the **Operation** section.

Before Calling for Service

Cooking

Symptoms	Possible Cause & Solution
Oven will not work	Plug on appliance is not completely inserted in the electrical outlet. <ul style="list-style-type: none"> • Make sure electrical plug is plugged into a live, properly grounded outlet.
	A fuse in your home may be blown or the circuit breaker tripped. <ul style="list-style-type: none"> • Replace the fuse or reset the circuit breaker.
	Oven controls improperly set. <ul style="list-style-type: none"> • See the "Operating the Oven" section in the Operation chapter.
	Oven too hot. <ul style="list-style-type: none"> • Allow the oven to cool to below locking temperature.
Steam is exhausted through the oven vent.	Cooking foods with high moisture produces steam. <ul style="list-style-type: none"> • This is normal.
Appliance does not operate.	Cord is not plugged in correctly. <ul style="list-style-type: none"> • Make sure cord is plugged correctly into outlet. Check circuit breakers.
	Service wiring is not complete. <ul style="list-style-type: none"> • Contact your electrician for assistance.
	Power outage. <ul style="list-style-type: none"> • Check house lights to be sure. Call your local electric company for service.
Oven smokes excessively during grilling.	Control not set properly. <ul style="list-style-type: none"> • Follow instructions under Setting Oven Controls.

Symptoms	Possible Cause & Solution
Oven smokes excessively during grilling.	Meat too close to the element. <ul style="list-style-type: none"> Reposition the rack to provide proper clearance between the meat and the element. Preheat grill element for searing.
	Meat not properly prepared. <ul style="list-style-type: none"> Remove excess fat from meat. Cut remaining fatty edges to prevent curling.
	Grease has built up on oven surfaces. Old grease or food spatters cause excessive smoking. <ul style="list-style-type: none"> Regular cleaning is necessary when grilling frequently.
Food does not bake or roast properly	Oven controls improperly set. <ul style="list-style-type: none"> See the "Operating the Oven" section in the Operation chapter.
	Rack position is incorrect or the rack is not level. <ul style="list-style-type: none"> See the "Operating the Oven" section in the Operation chapter.
	Incorrect cookware or cookware of improper size being used. <ul style="list-style-type: none"> See the "Operating the Oven" section in the Operation chapter.
Moisture collects on oven window or steam comes from oven vent	This happens when cooking foods high in moisture. <ul style="list-style-type: none"> This is normal.
	Excessive moisture was used when cleaning the window. <ul style="list-style-type: none"> Do not use excessive moisture when cleaning the window.
Warm air venting into kitchen after oven has been turned off.	Warm air exhaust is needed to maintain and cool down oven temperatures. It turns off automatically when the heat cools to a safe temperature. <ul style="list-style-type: none"> This is normal.

Parts & Features

Symptoms	Possible Cause & Solution
 is on in the display when you want to cook	The oven door is locked because the temperature inside the oven has not dropped below the locking temperature. <ul style="list-style-type: none"> Press the STOP button. Allow the oven to cool.
	The Control Lock is activated. <ul style="list-style-type: none"> Press the Control Lock button for 3 seconds to reset the function.
Oven light does not work.	It is time to replace the bulb or the bulb is loose. <ul style="list-style-type: none"> Replace or tighten bulb. See "Changing the Oven Light" section in this Owner's Manual.

Symptoms	Possible Cause & Solution
Cooling fan continues to run after oven is turned off.	<p>The fan turns off automatically when the electronic components have cooled sufficiently.</p> <ul style="list-style-type: none"> This is normal.
Oven will not start Pyrolysis.	<p>The oven temperature is too high to set a Pyrolysis operation.</p> <ul style="list-style-type: none"> Allow the appliance to cool and reset the controls.
	<p>Oven controls improperly set.</p> <ul style="list-style-type: none"> See the Pyrolysis section.
	<p>A pyrolysis cycle cannot be started if the oven door is open.</p> <ul style="list-style-type: none"> Close the oven door.
Oven door does not open after a Pyrolysis cycle.	<p>Oven is too hot.</p> <ul style="list-style-type: none"> Allow the oven to cool below locking temperature.
	<p>The control and door may be locked.</p> <ul style="list-style-type: none"> Allow about one hour for the oven to cool after the completion of a Pyrolysis cycle. The door can be opened when the lock  is no longer displayed during Pyrolysis cycle.
	<p>The Control Lock is activated.</p> <ul style="list-style-type: none"> Press the Control Lock button for 3 seconds to reset the function.
The oven is not clean after a Pyrolysis cycle.	<p>Oven controls not properly set.</p> <ul style="list-style-type: none"> See the Pyrolysis section.
	<p>Oven was heavily soiled.</p> <ul style="list-style-type: none"> Clean up heavy spillovers before starting the clean cycle. Heavily soiled ovens may need to do Pyrolysis again or for a longer period of time.
Convection fan stops.	<p>Convection fan stops during a convection bake cycle. It is done to allow more even heating during the cycle.</p> <ul style="list-style-type: none"> This is not a failure of the range and should be considered normal operation.
Oven racks are difficult to slide.	<p>The shiny, silver-colored racks were cleaned.</p> <ul style="list-style-type: none"> Apply a small amount of vegetable oil to a paper towel and wipe the edges of the oven racks with the paper towel.

Noises

Symptoms	Possible Cause & Solution
“Crackling” or “popping” sound	<p>This is the sound of the metal heating and cooling during both the cooking and Pyrolysis functions.</p> <ul style="list-style-type: none"> This is normal.

Symptoms	Possible Cause & Solution
Fan noise	<p>A convection fan may automatically turn on and off.</p> <ul style="list-style-type: none"> This is normal.

Wi-Fi

Symptoms	Possible Cause & Solution
Your home appliance and smartphone are not connected to the Wi-Fi network.	<p>The password for the Wi-Fi that you are trying to connect to is incorrect.</p> <ul style="list-style-type: none"> Find the Wi-Fi network connected to your smartphone and remove it, then register your appliance on LG ThinQ.
	<p>Mobile data for your smartphone is turned on.</p> <ul style="list-style-type: none"> Turn off the Mobile data of your smartphone and register the appliance using the Wi-Fi network.
	<p>The wireless network name (SSID) is set incorrectly.</p> <ul style="list-style-type: none"> The wireless network name (SSID) should be a combination of English letters and numbers. (Do not use special characters.)
	<p>The router frequency is not 2.4 GHz.</p> <ul style="list-style-type: none"> Only a 2.4 GHz router frequency is supported. Set the wireless router to 2.4 GHz and connect the appliance to the wireless router. To check the router frequency, check with your Internet service provider or the router manufacturer.
	<p>The distance between the appliance and the router is too far.</p> <ul style="list-style-type: none"> If the distance between the appliance and the router is too far, the signal may be weak and the connection may not be configured correctly. Move the location of the router so that it is closer to the appliance.

Customer Service & Spare Parts

Customer Service

If the fault cannot be rectified by the above measures, contact the LG Customer Information Center for service.

Please find the contact data of all countries in the enclosed warranty card.

- If faulty, the appliance must not be used. If a fault occurs, the appliance must be isolated by removing the mains plug or switched off by removing the fuse or turning off the circuit breaker in the house fuse box.
- The appliance must only be repaired by a specially trained and qualified electrical professional. Repairs carried out improperly may result in considerable damage or injury.

CAUTION

- Repairs to the appliance must be carried out by a specially licensed technician only. Considerable danger may result from incorrect repairs.

- Do not use the appliance if damaged. In the event of a fault or failure, switch off at the mains. In the event of a fault, visits by technicians from Customer Service or dealers may not be covered by the warranty if the cause of failure is the result of abnormal customer use.

Spare Parts

If you require spare parts or a technician, contact the LG Service.

- Your call will be automatically passed on to the Customer Service Centre responsible for your post code area.
- You can find the address of your local Customer Service Centre and other information for customers on the Internet at www.lg.com

Please ensure you have the following details to hand:

- Your name and address, including your post code.
- Your telephone number.
- Exact details of the nature of the problem.
- The model, series and serial number. These details are found on the rating plate located at the left-hand inner edge of the oven door.
- Your dated receipt of purchase. Please note that proof of purchase is required for any warranty claim. Before requesting a warranty claim, please ensure that you have read through the section on "TROUBLESHOOTING". There will be a charge for any inspection carried out by a technician if it should transpire that there is no mechanical or electrical fault present in the appliance.

After Sales Service (Egypt Only)

- Shelf Life Time : 6 Years
- LG is committed to providing all spare parts of this appliance during the shelf life time.

Memo

Memo

